

C H A P T E R 29

Learning Objectives

- Motor Principle
- Comparison of Generator and Motor Action
- Significance of the Back e.m.f.—Voltage Equation of a Motor
- Conditions for Maximum Power
- Torque
- Armature Torque of a Motor
- Shaft Torque
- Speed of a D.C. Motor
- Speed Regulation Torque and Speed of a D.C. Motor
- Motor Characteristics
- Characteristics of Series Motors
- Characteristics of Shunt Motors
- Compound Motors
- Performance Curves
- Comparison of Shunt and Series Motors
- Losses and Efficiency
- Power Stages

D.C. MOTOR



C Design for optimum performance and durability in demanding variable speed motor applications. D.C. motors have earned a reputation for dependability in severe operating conditions

29.1. Motor Principle

An Electric motor is a machine which converts electric energy into mechanical energy. Its action is based on the principle that when a current-carrying conductor is placed in a magnetic field, it experiences a mechanical force whose direction is given by Fleming's Left-hand Rule and whose magnitude is given by $F = BIl$ Newton.

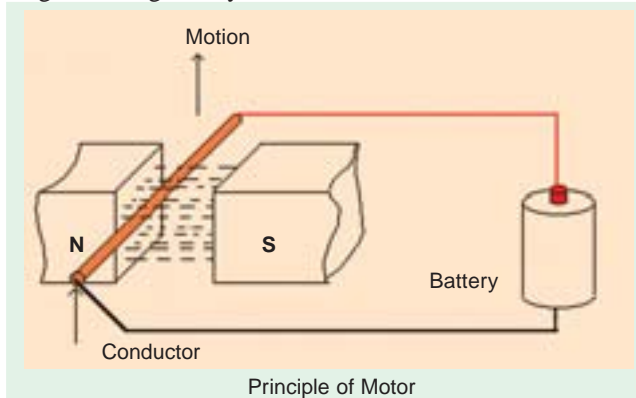

Constructionally, there is no basic difference between a d.c. generator and a d.c. motor. In fact, the same d.c. machine can be used interchangeably as a generator or as a motor. D.C. motors are also like generators, shunt-wound or series-wound or compound-wound.

In Fig. 29.1 a part of multipolar d.c. motor is shown. When its field magnets are excited and its armature conductors

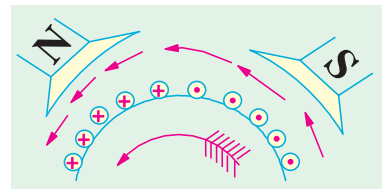

Fig. 29.1

are supplied with current from the supply mains, they experience a force tending to rotate the armature. Armature conductors under *N*-pole are assumed to carry current downwards (crosses) and those under *S*-poles, to carry current upwards (dots). By applying Fleming's Left-hand Rule, the direction of the force on each conductor can be found. It is shown by small arrows placed above each conductor. It will be seen that each conductor experiences a force F which tends to rotate the armature in anticlockwise direction. These forces collectively produce a driving torque which sets the armature rotating.

It should be noted that the function of a commutator in the motor is the same as in a generator. By reversing current in each conductor as it passes from one pole to another, it helps to develop a continuous and unidirectional torque.

29.2. Comparison of Generator and Motor Action

As said above, the same d.c. machine can be used, at least theoretically, interchangeably as a generator or as a motor. When operating as a generator, it is driven by a mechanical machine and it develops voltage which in turn produces a current flow in an electric circuit. When operating as a motor, it is supplied by electric current and it develops torque which in turn produces mechanical rotation.

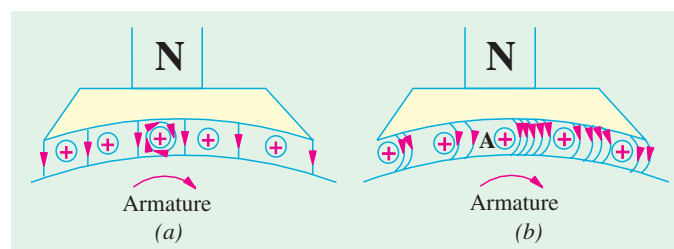

Fig. 29.2

Let us first consider its operation as a generator and see how exactly and through which agency, mechanical power is converted into electric power.

In Fig. 29.2 part of a generator whose armature is being driven clockwise by its prime mover is shown.

Fig. 29.2 (a) represents the fields set up independently by the main poles and the armature conductors like *A* in the figure. The resultant field or magnetic lines on flux are shown in Fig. 29.2 (b).

It is seen that there is a crowding of lines of flux on the right-hand side of A. These magnetic lines of flux may be likened to the rubber bands under tension. Hence, the bent lines of flux up a mechanical force on A much in the same way as the bent elastic rubber band of a catapult produces a mechanical force on the stone piece. It will be seen that this force is in a direction opposite to that of armature rotation. Hence, it is known as backward force or magnetic drag on the conductors. It is against this drag action on all armature conductor that the prime mover has to work. The work done in overcoming this opposition is converted into electric energy. Therefore, it should be clearly understood that it is only through the instrumentality of this magnetic drag that energy conversion is possible in a d.c. generator*.

Next, suppose that the above d.c. machine is uncoupled from its prime mover and that current is sent through the armature conductors under a N-pole in the downward direction as shown in Fig. 29.3 (a). The conductors will again experience a force in the anticlockwise direction (Fleming's Left hand Rule). Hence, the machine will start rotating anticlockwise, thereby developing a torque which can produce mechanical rotation. The machine is then said to be motoring.

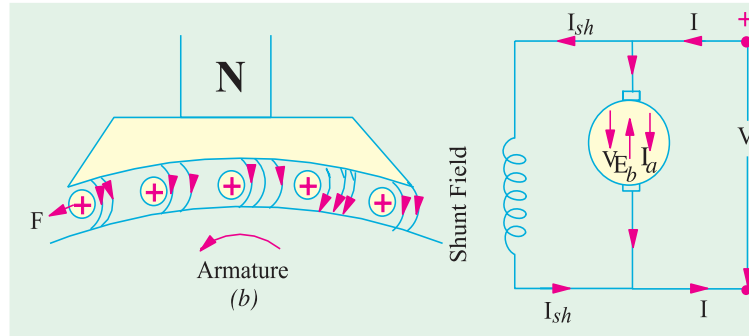

Fig. 29.3 (a)

Fig. 29.3 (b)

As said above, energy conversion is not possible unless there is some opposition whose overcoming provides the necessary means for such conversion. In the case of a generator, it was the magnetic drag which provided the necessary opposition. But what is the equivalent of that drag in the case of a motor? Well, it is the back e.m.f. It is explained in this manner:

As soon as the armature starts rotating, dynamically (or motionally) induced e.m.f. is produced in the armature conductors. The direction of this induced e.m.f. as found by Fleming's Right-hand Rule, is outwards *i.e.*, in direct opposition to the applied voltage (Fig. 29.3 (b)). This is why it is known as back e.m.f. E_b or counter e.m.f. Its value is the same as for the motionally induced e.m.f. in the generator *i.e.* $E_b = (\Phi Z N) \times (P/A)$ volts. The applied voltage V has to force current through the armature conductors against this back e.m.f. E_b . The electric work done in overcoming this opposition is converted into mechanical energy developed in the armature. Therefore, it is obvious that but for the production of this opposing e.m.f. energy conversion would not have been possible.

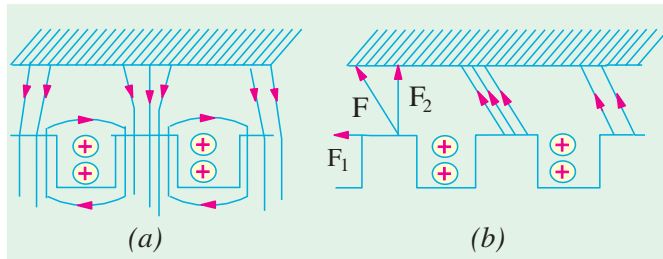

Fig. 29.4

Now, before leaving this topic, let it be pointed out that in an actual

motor with slotted armature, the torque is not due to mechanical force on the conductors themselves, but due to tangential pull on the armature teeth as shown in Fig. 29.4.

It is seen from Fig. 29.4 (a) that the main flux is concentrated in the form of tufts at the armature teeth while the armature flux is shown by the dotted lines embracing the armature slots. The effect of

* In fact, it seems to be one of the fundamental laws of Nature that no energy conversion from one form to another is possible until there is some one to oppose the conversion. But for the presence of this opposition, there would simply be no energy conversion. In generators, opposition is provided by magnetic drag whereas in motors, back e.m.f. does this job. Moreover, it is only that part of the input energy which is used for overcoming this opposition that is converted into the other form.

armature flux on the main flux, as shown in Fig. 29.4 (b), is two-fold :

- (i) It increases the flux on the left-hand side of the teeth and decreases it on the right-hand side, thus making the distribution of flux density across the tooth section unequal.
- (ii) It inclines the direction of lines of force in the air-gap so that they are not radial but are disposed in a manner shown in Fig. 29.4 (b). The pull exerted by the poles on the teeth can now be resolved into two components. One is the tangential component F_1 and the other vertical component F_2 . The vertical component F_2 , when considered for all the teeth round the armature, adds up to zero. But the component F_1 is not cancelled and it is this tangential component which, acting on all the teeth, gives rise to the armature torque.

29.3. Significance of the Back e.m.f.

As explained in Art 29.2, when the motor armature rotates, the conductors also rotate and hence cut the flux. In accordance with the laws of electromagnetic induction, e.m.f. is induced in them whose direction, as found by Fleming's Right-hand Rule, is in opposition to the applied voltage (Fig. 29.5). Because of its opposing direction, it is referred to as counter e.m.f. or back e.m.f. E_b . The equivalent circuit of a motor is shown in Fig. 29.6. The rotating armature generating the back e.m.f. E_b is like a battery of e.m.f. E_b put across a supply mains of V volts. Obviously, V has to drive I_a against the opposition of E_b . The power required to overcome this opposition is $E_b I_a$.

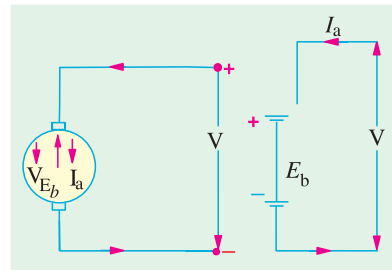

Fig. 29.5

In the case of a cell, this power over an interval of time is converted into chemical energy, but in the present case, it is converted into mechanical energy.

$$\text{It will be seen that } I_a = \frac{\text{Net voltage}}{\text{Resistance}} = \frac{V - E_b}{R_a}$$

where R_a is the resistance of the armature circuit. As pointed out above,

$$E_b = \Phi ZN \times (P/A) \text{ volt where } N \text{ is in r.p.s.}$$

Back e.m.f. depends, among other factors, upon the armature speed. If speed is high, E_b is large, hence armature current I_a , seen from the above equation, is small. If the speed is less, then E_b is less, hence more current flows which develops motor torque (Art 29.7). So, we find that E_b acts like a governor *i.e.*, it makes a motor self-regulating so that it draws as much current as is just necessary.

29.4. Voltage Equation of a Motor

The voltage V applied across the motor armature has to

- (i) overcome the back e.m.f. E_b and
- (ii) supply the armature ohmic drop $I_a R_a$.

$$\therefore V = E_b + I_a R_a$$

This is known as voltage equation of a motor.

Now, multiplying both sides by I_a , we get

$$V I_a = E_b I_a + I_a^2 R_a$$

As shown in Fig. 29.6,

$$V I_a = \text{Electrical input to the armature}$$

$$E_b I_a = \text{Electrical equivalent of mechanical power developed in the armature}$$

$$I_a^2 R_a = \text{Cu loss in the armature}$$

Hence, out of the armature input, some is wasted in $I^2 R$ loss and the rest is converted into mechanical power *within* the armature.

It may also be noted that motor efficiency is given by the ratio of power developed by the arma-

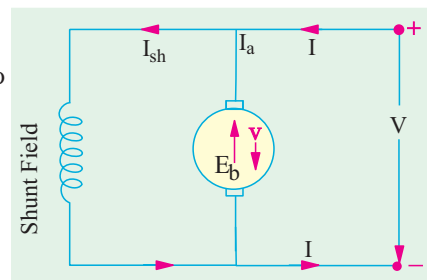

Fig. 29.6

ture to its input *i.e.*, $E_b I_a / V I_a = E_b / V$. Obviously, higher the value of E_b as compared to V , higher the motor efficiency.

29.5. Condition for Maximum Power

The gross mechanical power developed by a motor is $P_m = V I_a - I_a^2 R_a$.

Differentiating both sides with respect to I_a and equating the result to zero, we get

$$dP_m/dI_a = V - 2I_a R_a = 0 \quad \therefore I_a R_a = V/2$$

$$\text{As } V = E_b + I_a R_a \quad \text{and } I_a R_a = V/2 \quad \therefore E_b = V/2$$

Thus gross mechanical power developed by a motor is maximum when back e.m.f. is equal to half the applied voltage. This condition is, however, not realized in practice, because in that case current would be much beyond the normal current of the motor. Moreover, half the input would be wasted in the form of heat and taking other losses (mechanical and magnetic) into consideration, the motor efficiency will be well below 50 percent.

Example 29.1. A 220-V d.c. machine has an armature resistance of 0.5Ω . If the full-load armature current is 20 A, find the induced e.m.f. when the machine acts as (i) generator (ii) motor.

(Electrical Technology-I, Bombay Univ. 1987)

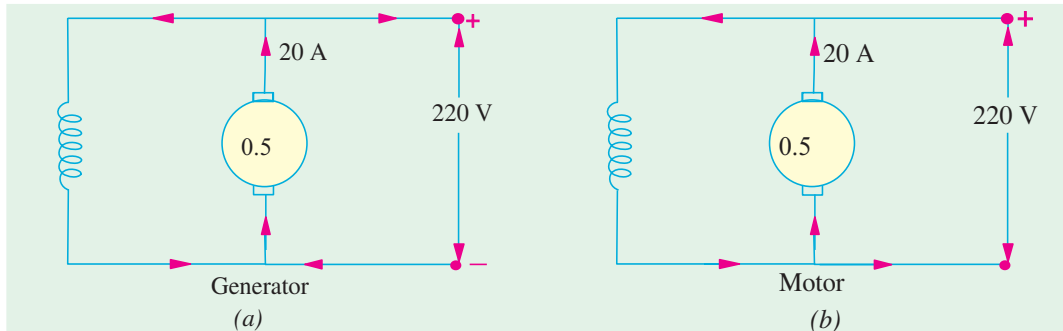

Fig. 29.7

Solution. As shown in Fig. 29.7, the d.c. machine is assumed to be shunt-connected. In each case, shunt current is considered negligible because its value is not given.

(a) As Generator [Fig. 29.7(a)] $E_g = V + I_a R_a = 220 + 0.5 \times 20 = 230 \text{ V}$

(b) As Motor [Fig. 29.7 (b)] $E_b = V - I_a R_a = 220 - 0.5 \times 20 = 210 \text{ V}$

Example 29.2. A separately excited D.C. generator has armature circuit resistance of 0.1 ohm and the total brush-drop is 2 V . When running at 1000 r.p.m. , it delivers a current of 100 A at 250 V to a load of constant resistance. If the generator speed drop to 700 r.p.m. , with field-current unaltered, find the current delivered to load. (AMIE, Electrical Machines, 2001)

Solution. $R_L = 250/100 = 2.5 \text{ ohms.}$

$$E_{g1} = 250 + (100 \times 0.1) + 2 = 262 \text{ V.}$$

$$\text{At } 700 \text{ r.p.m., } E_{g2} = 262 \times 700/1000 = 183.4 \text{ V}$$

$$\text{If } I_a \text{ is the new current, } E_{g2} - 2 - (I_a \times 0.1) = 2.5 I_a$$

This gives $I_a = 96.77 \text{ amp.}$

Extension to the Question : With what load resistance will the current be 100 amp , at 700 r.p.m. ?

$$\text{Solution. } E_{g2} - 2 - (I_a \times 0.1) = R_L \times I_a$$

For $I_a = 100 \text{ amp}$, and $E_{g2} = 183.4 \text{ V}$, $R_L = 1.714 \text{ ohms.}$

Example 29.3. A 440-V , shunt motor has armature resistance of 0.8Ω and field resistance of 200Ω . Determine the back e.m.f. when giving an output of 7.46 kW at $85 \text{ percent efficiency.}$

Solution. Motor input power = $7.46 \times 10^3 / 0.85 \text{ W}$

Motor input current = $7460/0.85 \times 440 = 19.95 \text{ A}$; $I_{sh} = 440/200 = 2.2 \text{ A}$

$I_a = 19.95 - 2.2 = 17.75 \text{ A}$; Now, $E_b = V - I_a R_a$

$\therefore E_b = 440 - (17.75 \times 0.8) = 425.8 \text{ V}$

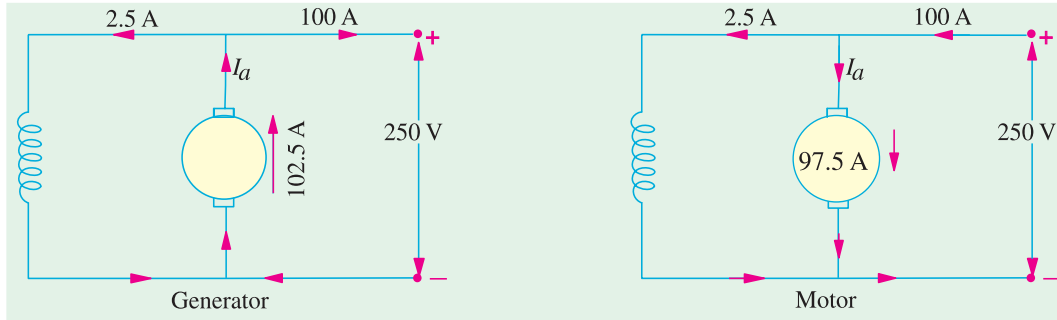

Fig. 29.8 (a)

Fig. 29.8 (b)

Example 29.4. A 25-kW, 250-V, d.c. shunt generator has armature and field resistances of 0.06Ω and 100Ω respectively. Determine the total armature power developed when working (i) as a generator delivering 25 kW output and (ii) as a motor taking 25 kW input.

(Electrical Technology, Punjab Univ., June 1991)

Solution. As Generator [Fig. 29.8 (a)]

Output current = $25,000/250 = 100 \text{ A}$; $I_{sh} = 250/100 = 2.5 \text{ A}$; $I_a = 102.5 \text{ A}$

Generated e.m.f. = $250 + I_a R_a = 250 + 102.5 \times 0.06 = 256.15 \text{ V}$

Power developed in armature = $E_b I_a = \frac{256.15 \times 102.5}{1000} = 26.25 \text{ kW}$

As Motor [Fig 29.8 (b)]

Motor input current = 100 A ; $I_{sh} = 2.5 \text{ A}$, $I_a = 97.5 \text{ A}$

$E_b = 250 - (97.5 \times 0.06) = 250 - 5.85 = 244.15 \text{ V}$

Power developed in armature = $E_b I_a = 244.15 \times 97.5/1000 = 23.8 \text{ kW}$

Example 29.5. A 4 pole, 32 conductor, lap-wound d.c. shunt generator with terminal voltage of 200 volts delivering 12 amps to the load has $r_a = 2$ and field circuit resistance of 200 ohms. It is driven at 1000 r.p.m. Calculate the flux per pole in the machine. If the machine has to be run as a motor with the same terminal voltage and drawing 5 amps from the mains, maintaining the same magnetic field, find the speed of the machine. [Sambalpur University, 1998]

Solution. Current distributions during two actions are indicated in Fig. 29.9 (a) and (b). As a generator, $I_a = 13 \text{ amp}$

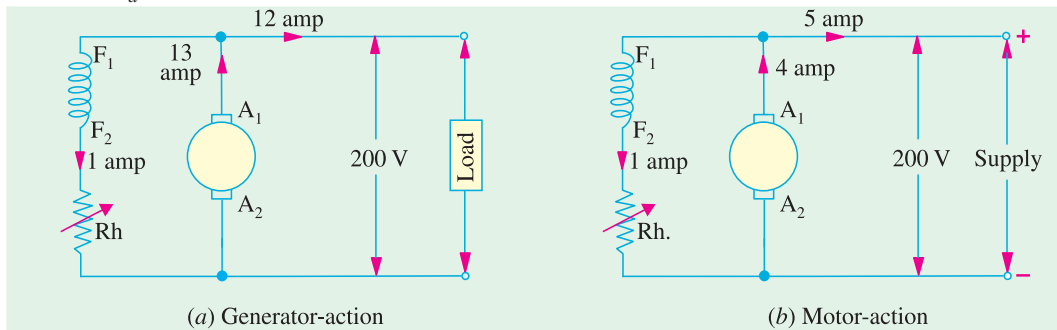

Fig. 29.9

$E_g = 200 + 13 \times 2 = 226 \text{ V}$

$$\phi \frac{ZN}{60} \times \frac{P}{a} = 226$$

For a Lap-wound armature,

$$P = a$$

$$\therefore \phi = \frac{226 \times 60}{1000 \times 32} = 0.42375 \text{ wb}$$

As a motor,

$$I_a = 4 \text{ amp}$$

$$E_b = 200 - 4 \times 2 = 192 \text{ V}$$

$$= \phi ZN/60$$

$$\text{Giving } N = \frac{60 \times 192}{0.42375 \times 32}$$

$$= 850 \text{ r.p.m.}$$

Tutorial Problems 29.1

1. What do you understand by the term 'back e.m.f.'? A d.c. motor connected to a 460-V supply has an armature resistance of 0.15 Ω. Calculate

(a) The value of back e.m.f. when the armature current is 120 A.

(b) The value of armature current when the back e.m.f. is 447.4 V. **[(a) 442 V (b) 84 A]**

2. A d.c. motor connected to a 460-V supply takes an armature current of 120 A on full load. If the armature circuit has a resistance of 0.25 Ω, calculate the value of the back e.m.f. at this load. **[430 V]**

3. A 4-pole d.c. motor takes an armature current of 150 A at 440 V. If its armature circuit has a resistance of 0.15 Ω, what will be the value of back e.m.f. at this load? **[417.5 V]**

29.6. Torque

By the term torque is meant the turning or twisting moment of a force about an axis. It is measured by the product of the force and the radius at which this force acts.

Consider a pulley of radius r metre acted upon by a circumferential force of F Newton which causes it to rotate at N r.p.m. (Fig. 29.10).

Then torque $T = F \times r$ Newton-metre (N - m)

Work done by this force in one revolution

$$= \text{Force} \times \text{distance} = F \times 2\pi r \text{ Joule}$$

Power developed = $F \times 2\pi r \times N$ Joule/second or Watt

$$= (F \times r) \times 2\pi N \text{ Watt}$$

Now $2\pi N =$ Angular velocity ω in radian/second and $F \times r =$ Torque T

\therefore Power developed = $T \times \omega$ watt or $P = T \omega$ Watt

Moreover, if N is in r.p.m., then

$$\omega = \frac{2\pi N}{60} \text{ rad/s}$$

$$\therefore P = \frac{2\pi N}{60} \times T \text{ or } P = \frac{2\pi}{60} \cdot NT = \frac{NT}{9.55}$$

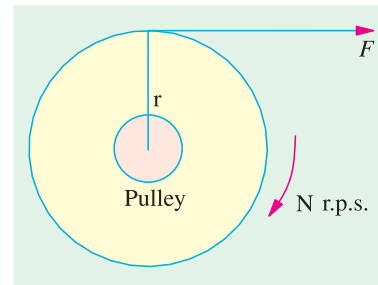

Fig. 29.10

29.7. Armature Torque of a Motor

Let T_a be the torque developed by the armature of a motor running at N r.p.s. If T_a is in N/M , then power developed = $T_a \times 2\pi N$ watt ...(i)

We also know that electrical power converted into mechanical power in the armature (Art 29.4)

$$= E_b I_a \text{ watt} \quad \dots(ii)$$

Equating (i) and (ii), we get $T_a \times 2\pi N = E_b I_a \quad \dots(iii)$

Since $E_b = \Phi ZN \times (P/A)$ volt, we have

$$T_a \times 2\pi N = \Phi ZN \left(\frac{P}{A}\right) \cdot I_a \text{ or } T_a = \frac{1}{2\pi} \cdot \Phi Z I_0 \left(\frac{P}{A}\right) N\text{-m}$$

$$= 0.159 \text{ N newton metre}$$

$$\therefore T_a = 0.159 \Phi Z I_a \times (P/A) N\text{-m}$$

Note. From the above equation for the torque, we find that $T_a \propto \Phi I_a$.

(a) In the case of a series motor, Φ is directly proportional to I_a (before saturation) because field windings carry full armature current $\therefore T_a \propto I_a^2$

(b) For shunt motors, Φ is practically constant, hence $T_a \propto I_a$.

As seen from (iii) above

$$T_a = \frac{E_b I_a}{2\pi N} \text{ N - m - N in r.p.s.}$$

If N is in r.p.m., then

$$T_a = \frac{E_b I_a}{2\pi N / 60} = 60 \frac{E_b I_a}{2\pi N} = \frac{60}{2\pi} \frac{E_b I_a}{N} = 9.55 \frac{E_b I_a}{N} \text{ N-m}$$

29.8. Shaft Torque (T_{sh})

The whole of the armature torque, as calculated above, is not available for doing useful work, because a certain percentage of it is required for supplying iron and friction losses in the motor.

The torque which is available for doing useful work is known as shaft torque T_{sh} . It is so called because it is available at the shaft. The motor output is given by

Output = $T_{sh} \times 2\pi N$ Watt provided T_{sh} is in N-m and N in r.p.s.

$$\therefore T_{sh} = \frac{\text{Output in watts}}{2\pi N} \text{ N- m -N in r.p.s}$$

$$= \frac{\text{Output in watts}}{2\pi N / 60} \text{ N-m -N in r.p.m.}$$

$$= \frac{60}{2\pi} \frac{\text{output}}{N} = 9.55 \frac{\text{Output}}{N} \text{ N-m.}$$

The difference ($T_a - T_{sh}$) is known as lost torque and is due to iron and friction losses of the motor.

Note. The value of back e.m.f. E_b can be found from

(i) the equation, $E_b = V - I_a R_a$

(ii) the formula $E_b = \Phi ZN \times (P/A)$ volt

Example 29.6. A d.c. motor takes an armature current of 110 A at 480 V. The armature circuit resistance is 0.2 Ω . The machine has 6-poles and the armature is lap-connected with 864 conductors. The flux per pole is 0.05 Wb. Calculate (i), the speed and (ii) the gross torque developed by the armature. **(Elect. Machines, A.M.I.E. Sec B, 1989)**

Solution. $E_b = 480 - 110 \times 0.2 = 458 \text{ V}, \quad \Phi = 0.05 \text{ Wb}, Z = 864$

Now, $E_b = \frac{\Phi ZN}{60} \left(\frac{P}{A}\right)$ or $458 = \frac{0.05 \times 864 \times N}{60} \times \left(\frac{6}{6}\right)$

$$\therefore N = 636 \text{ r.p.m.}$$

$$T_a = 0.159 \times 0.05 \times 864 \times 110 (6/6) = 756.3 \text{ N-m}$$

Example 29.7. A 250-V, 4-pole, wave-wound d.c. series motor has 782 conductors on its armature. It has armature and series field resistance of 0.75 ohm. The motor takes a current of 40 A. Estimate its speed and gross torque developed if it has a flux per pole of 25 mWb.

(Elect. Engg.-II, Pune Univ. 1991)

Solution.

$$E_b = \Phi ZN (P/A)$$

Now,

$$E_b = V - I_a R_a = 250 - 40 \times 0.75 = 220 \text{ V}$$

$$\therefore 220 = 25 \times 10^{-3} \times 782 \times N \times 0.75 = 220 \text{ V}$$

$$\therefore 220 = 0.159 \Phi Z I_a (P/A)$$

$$= 0.159 \times 25 \times 10^{-3} \times 782 \times 40 \times (4/2) = \mathbf{249 \text{ N-m}}$$

Example 29.8. A d.c. shunt machine develops an a.c. e.m.f. of 250 V at 1500 r.p.m. Find its torque and mechanical power developed for an armature current of 50 A. State the simplifying assumptions.

(Basic Elect. Machine Nagpur Univ., 1993)

Solution. A given d.c. machine develops the same e.m.f. in its armature conductors whether running as a generator or as a motor. Only difference is that this armature e.m.f. is known as back e.m.f. when the machine is running as a motor.

$$\text{Mechanical power developed in the arm} = E_b I_a = 250 \times 50 = 12,500 \text{ W}$$

$$T_a = 9.55 E_b I_a / N = 9.55 \times 250 \times 50 / 1500 = \mathbf{79.6 \text{ N-m.}}$$

Example 29.9. Determine developed torque and shaft torque of 220-V, 4-pole series motor with 800 conductors wave-connected supplying a load of 8.2 kW by taking 45 A from the mains. The flux per pole is 25 mWb and its armature circuit resistance is 0.6 Ω .

(Elect. Machine AMIE Sec. B Winter 1991)

Solution. Developed torque or gross torque is the same thing as armature torque.

$$\therefore T_a = 0.159 \Phi Z A (P/A)$$

$$= 0.159 \times 25 \times 10^{-3} \times 800 \times 45 (4/2) = 286.2 \text{ N-m}$$

$$E_b = V - I_a R_a = 220 - 45 \times 0.6 = 193 \text{ V}$$

Now,

$$E_b = \Phi ZN (P/A) \text{ or } 193 = 25 \times 10^{-3} \times 800 \times N \pi \times (4/2)$$

$$\therefore N = 4.825 \text{ r.p.s.}$$

Also,

$$2\pi N T_{sh} = \text{output or } 2\pi \times 4.825 T_{sh} = 8200 \quad \therefore T_{sh} = 270.5 \text{ N-m}$$

Example 29.10. A 220-V d.c. shunt motor runs at 500 r.p.m. when the armature current is 50 A. Calculate the speed if the torque is doubled. Given that $R_a = 0.2 \Omega$.

(Electrical Technology-II, Gwalior Univ. 1985)

Solution. As seen from Art 27.7, $T_a \propto \Phi I_a$. Since Φ is constant, $T_a \propto I_a$

$$\therefore T_{a1} \propto I_{a1} \text{ and } T_{a2} \propto I_{a2} \quad \therefore T_{a2}/T_{a1} = I_{a2}/I_{a1}$$

$$\therefore 2 = I_{a2}/50 \text{ or } I_{a2} = 100 \text{ A}$$

$$\text{Now, } N_2/N_1 = E_{b2}/E_{b1} \quad \text{— since } \Phi \text{ remains constant.}$$

$$E_{b1} = 220 - (50 \times 0.2) = 210 \text{ V} \quad E_{b2} = 220 - (100 \times 0.2) = 200 \text{ V}$$

$$\therefore N_2/500 = 200/210 \quad \therefore N_2 = \mathbf{476 \text{ r.p.m.}}$$

Example 29.11. A 500-V, 37.3 kW, 1000 r.p.m. d.c. shunt motor has on full-load an efficiency of 90 percent. The armature circuit resistance is 0.24 Ω and there is total voltage drop of 2 V at the brushes. The field current is 1.8 A. Determine (i) full-load line current (ii) full load shaft torque in N-m and (iii) total resistance in motor starter to limit the starting current to 1.5 times the full-load current.

(Elect. Engg. I; M.S. Univ. Baroda 1987)

Solution. (i) Motor input = 37,300/0.9 = 41,444 W

$$\text{F.L. line current} = 41,444/500 = \mathbf{82.9 \text{ A}}$$

$$(ii) \quad T_{sh} = 9.55 \frac{\text{output}}{N} = 9.55 \times \frac{37,300}{1000} = 356 \text{ N-m}$$

$$(iii) \quad \text{Starting line current} = 1.5 \times 82.9 = 124.3 \text{ A}$$

$$\text{Arm. current at starting} = 124.3 - 1.8 = 122.5 \text{ A}$$

If R is the starter resistance (which is in series with armature), then
 $122.5 (R + 0.24) + 2 = 500 \quad \therefore R = 3.825 \Omega$

Example 29.12. A 4-pole, 220-V shunt motor has 540 lap-wound conductor. It takes 32 A from the supply mains and develops output power of 5.595 kW. The field winding takes 1 A. The armature resistance is 0.09Ω and the flux per pole is 30 mWb. Calculate (i) the speed and (ii) the torque developed in newton-metre. (Electrical Technology, Nagpur Univ. 1992)

Solution. $I_a = 32 - 1 = 31 \text{ A}$; $E_b = V - I_a R_a = 220 - (0.09 \times 31) = 217.2 \text{ V}$

Now,
$$E_b = \frac{\Phi ZN}{60} \left(\frac{P}{A} \right) \quad \therefore 217.2 = \frac{30 \times 10^{-3} \times 540 \times N}{60} \left(\frac{4}{4} \right)$$

(i) $\therefore N = 804.4 \text{ r.p.m.}$

(ii)
$$T_{sh} = 9.55 \times \frac{\text{output in watts}}{N} = 9.55 \times \frac{5,595}{804.4} = 66.5 \text{ N-m}$$

Example 29.13 (a). Find the load and full-load speeds for a four-pole, 220-V, and 20-kW, shunt motor having the following data :

Field-current = 5 amp, armature resistance = 0.04 ohm,

Flux per pole = 0.04 Wb, number of armature-conductors = 160, Two-circuit wave-connection, full load current = 95 amp, No load current = 9 A. Neglect armature reaction.

(Bharathithasan Univ. April 1997)

Solution. The machine draws a supply current of 9 amp at no load. Out of this, 5 amps are required for the field circuit, hence the armature carries a no-load current of 4 amp.

At load, armature-current is 90 amp. The armature-resistance-drop increases and the back e.m.f. decreases, resulting into decrease in speed under load compared to that at No-Load.

At No Load : $E_{ao} = 220 - 4 \times 0.04 = 219.84 \text{ volts}$

Substituting this,

$$0.04 \times 160 \times (N/60) \times (4/2) = 219.84$$

No-Load speed, $N_0 = 1030.5 \text{ r.p.m.}$

At Full Load : Armature current = 90 A, $E_a = 200 - 90 \times 0.04 = 216.4 \text{ V}$

$$N = (216.4/219.84) \times 1030.5 = 1014.4 \text{ r.p.m.}$$

Example 29.13 (b). Armature of a 6-pole, 6-circuit D.C. shunt motor takes 400 A at a speed of 350 r.p.m. The flux per pole is 80 milli-webers, the number of armature turns is 600, and 3% of the torque is lost in windage, friction and iron-loss. Calculate the brake-horse-power.

(Manonmaniam Sundaranar Univ. Nov. 1998)

Solution. Number of armature turns = 600

Therefore, $Z = \text{Number of armature conductors} = 1200$

If electromagnetic torque developed is $T \text{ Nw - m}$,

$$\begin{aligned} \text{Armature power} &= T \omega = T \times 2 \pi 350/60 \\ &= 36.67 T \text{ watts} \end{aligned}$$

To calculate armature power in terms of Electrical parameters, E must be known.

$$E = \phi Z (N/60) (P/A)$$

$$= 80 \times 10^{-3} \times 1200 \times (350/60) \times (6/6)$$

$$= 560 \text{ volts}$$

With the armature current of 400 A, Armature power = 560 × 400 watts

Equating the two,

$T = 560 \times 400/36.67 = 6108.5 \text{ Nw - m}$. Since 3 % of this torque is required for overcoming different loss-terms,

$$\text{Net torque} = 0.97 \times 6108.5 = 5925 \text{ Nw - m}$$

For Brake-Horse-Power, net output in kW should be computed first. Then “kW” is to be converted to “BHP”, with 1 HP = 0.746 kW.

$$\text{Net output in kW} = 5925 \times 36.67 \times 10^{-3} = 217.27 \text{ kW}$$

Converting this to BHP, the output = 291.25 HP

Example 29.13 (c). Determine the torque established by the armature of a four-pole D.C. motor having 774 conductors, two paths in parallel, 24 milli-webers of pole-flux and the armature current is 50 Amps. (Bharathiar Univ. April 1998)

Solution. Expression for torque in terms of the parameters concerned in this problem is as follows :

$$T = 0.159 \phi Z I_a p/a \text{ Nw - m}$$

Two paths in parallel for a 4-pole case means a wave winding.

$$T = 0.159 \times (24 \times 10^{-3}) \times 774 \times 50 \times 4/2$$

$$= 295.36 \text{ Nw-m}$$

Example 29.13 (d). A 500-V D.C. shunt motor draws a line-current of 5 A on light-load. If armature resistance is 0.15 ohm and field resistance is 200 ohms, determine the efficiency of the machine running as a generator delivering a load current of 40 Amps. (Bharathiar Univ. April 1998)

Solution. (i) No Load, running as a motor :

$$\text{Input Power} = 500 \times 5 = 2500 \text{ watts}$$

$$\text{Field copper-loss} = 500 \times 2.5 = 1250 \text{ watts}$$

Neglecting armature copper-loss at no load (since it comes out to be $2.5^2 \times 0.15 = 1$ watt), the balance of 1250 watts of power goes towards no load losses of the machine running at rated speed. These losses are mainly the no load mechanical losses and the core-loss.

(ii) As a Generator, delivering 40 A to load :

$$\text{Output delivered} = 500 \times 40 \times 10^{-3} = 20 \text{ kW}$$

Losses : **(a)** Field copper-loss = 1250 watts

(b) Armature copper-loss = $42.5^2 \times 0.15 = 271$ watts

(c) No load losses = 1250 watts

Total losses = 2.771 kW

Generator Efficiency = $(20/22.771) \times 100 \% = 87.83 \%$

Extension to the Question : At what speed should the Generator be run, if the shunt-field is not changed, in the above case ? Assume that the motor was running at 600 r.p.m. Neglect armature reaction.

Solution. As a motor on no-load,

$$E_{b0} = 500 - I_a r_a = 500 - 0.15 \times 2.5 = 499.625 \text{ V}$$

As a Generator with an armature current of 42.5 A,

$$E_{b0} = 500 + 42.5 \times 0.15 = 506.375 \text{ V}$$

Since, the terminal voltage is same in both the cases, shunt field current remains as 2.5 amp. With armature reaction is ignored, the flux/pole remains same. The e.m.f. then becomes proportional to the speed. If the generator must be driven at N r.p.m.

$$N = (506.375/449.625) \times 600 = 608.1 \text{ r.p.m.}$$

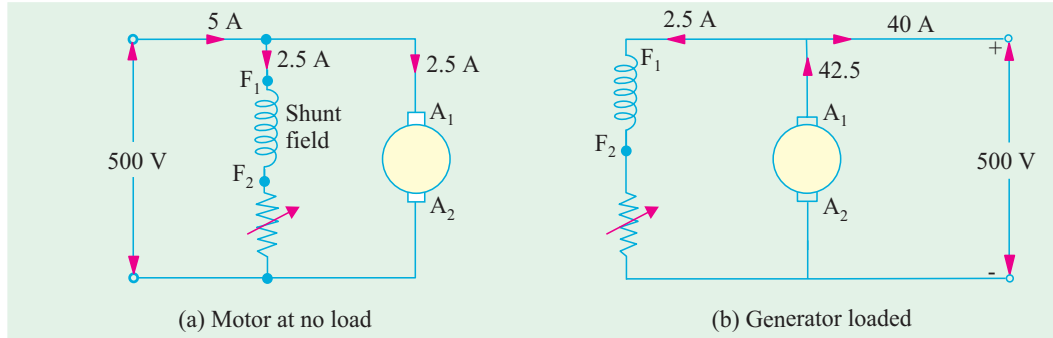

Fig. 29.11

Note. Alternative to this slight increase in the speed is to increase the field current with the help of decreasing the rheostatic resistance in the field-circuit.

Example 29.13 (e). A d.c. series motor takes 40 A at 220 V and runs at 800 r.p.m. If the armature and field resistance are 0.2 Ω and 0.1 Ω respectively and the iron and friction losses are 0.5 kW, find the torque developed in the armature. What will be the output of the motor ?

Solution. Armature torque is given by $T_a = 9.55 \frac{E_b I_a}{N}$ N-m

Now $E_b = V - I_a (R_a + R_{se}) = 220 - 40 (0.2 + 0.1) = 208 \text{ V}$

$\therefore T_a = 9.55 \times 208 \times 40/800 = 99.3 \text{ N-m}$

Cu loss in armature and series-field resistance = $40^2 \times 0.3 = 480 \text{ W}$

Iron and friction losses = 500 W ; Total losses = 480 + 500 = 980 W

Motor power input = $220 \times 40 = 8,800 \text{ W}$

Motor output = $8,800 - 980 = 7,820 \text{ W} = 7.82 \text{ kW}$

Example 29.14. A cutting tool exerts a tangential force of 400 N on a steel bar of diameter 10 cm which is being turned in a simple lathe. The lathe is driven by a chain at 840 r.p.m. from a 220 V d.c. Motor which runs at 1800 r.p.m. Calculate the current taken by the motor if its efficiency is 80 %. What size is the motor pulley if the lathe pulley has a diameter of 24 cm ?

(Elect. Technology-II, Gwalior Univ. 1985)

Solution. Torque $T_{sh} = \text{Tangential force} \times \text{radius} = 400 \times 0.05 = 20 \text{ N-m}$

Output power = $T_{sh} \times 2\pi N \text{ watt} = 20 \times 2\pi \times (840/60) \text{ watt} = 1,760 \text{ W}$

Motor $\eta = 0.8 \therefore$ Motor input = $1,760/0.8 = 2,200 \text{ W}$

Current drawn by motor = $2200/220 = 10 \text{ A}$

Let N_1 and D_1 be the speed and diameter of the driver pulley respectively and N_2 and D_2 the respective speed and diameter of the lathe pulley.

Then $N_1 \times D_1 = N_2 \times D_2$ or $1,800 \times D_1 = 840 \times 0.24$

$\therefore D_1 = 840 \times 0.24/1,800 = 0.112 \text{ m} = 11.2 \text{ cm}$

Example 29.15. The armature winding of a 200-V, 4-pole, series motor is lap-connected. There are 280 slots and each slot has 4 conductors. The current is 45 A and the flux per pole is 18 mWb. The field resistance is 0.3 Ω; the armature resistance 0.5 Ω and the iron and friction losses total 800 W. The pulley diameter is 0.41 m. Find the pull in newton at the rim of the pulley.

(Elect. Engg. AMIETE Sec. A. 1991)

Solution.

$$E_b = V - I_a R_a = 200 - 45(0.5 + 0.3) = 164 \text{ V}$$

Now

$$E_b = \frac{\Phi ZN}{60} \cdot \left(\frac{P}{A}\right) \text{ volt}$$

$$\therefore 164 = \frac{18 \times 10^{-3} \times 280 \times 4 \times N}{60} \times \frac{4}{4} \quad \therefore N = 488 \text{ r.p.m.}$$

$$\text{Total input} = 200 \times 45 = 9,000 \text{ W ; Cu loss} = I_a^2 R_a = 45^2 \times 0.8 = 1,620 \text{ W}$$

$$\text{Iron + Friction losses} = 800 \text{ W ; Total losses} = 1,620 + 800 = 2,420 \text{ W}$$

$$\text{Output} = 9,000 - 2,420 = 6,580 \text{ W}$$

$$\therefore T_{sh} = 9 \times 55 \times \frac{6580}{488} = 128 \text{ N-m}$$

Let F be the pull in newtons at the rim of the pulley.

$$\text{Then } F \times 0.205 = 128.8 \quad \therefore F = 128.8/0.205 \text{ N} = \mathbf{634 \text{ N}}$$

Example 29.16. A 4-pole, 240 V, wave connected shunt motor gives 1119 kW when running at 1000 r.p.m. and drawing armature and field currents of 50 A and 1.0 A respectively. It has 540 conductors. Its resistance is 0.1 Ω. Assuming a drop of 1 volt per brush, find (a) total torque (b) useful torque (c) useful flux / pole (d) rotational losses and (e) efficiency.

Solution.

$$E_b = V - I_a R_a - \text{brush drop} = 240 - (50 \times 0.1) - 2 = 233 \text{ V}$$

Also

$$I_a = 50 \text{ A}$$

$$(a) \quad \text{Armature torque } T_a = 9.55 \frac{E_b I_a}{N} \text{ N-m} = 9.55 \times \frac{233 \times 50}{1000} = \mathbf{111 \text{ N-m}}$$

$$(b) \quad T_{sh} = 9.55 \frac{\text{output}}{N} = 9.55 \times \frac{11,190}{1000} = \mathbf{106.9 \text{ N-m}}$$

$$(c) \quad E_b = \frac{\Phi ZN}{60} \times \left(\frac{P}{A}\right) \text{ volt}$$

$$\therefore 233 = \frac{\Phi \times 540 \times 1000}{60} \times \left(\frac{4}{2}\right) \quad \therefore \Phi = \mathbf{12.9 \text{ mWb}}$$

$$(d) \quad \text{Armature input} = V I_a = 240 \times 50 = \mathbf{12,000 \text{ W}}$$

$$\text{Armature Cu loss} = I_a^2 R_a = 50^2 \times 0.1 = 250 \text{ W ; Brush contact loss} = 50 \times 2 = 100 \text{ W}$$

$$\therefore \text{Power developed} = 12,000 - 350 = 11,650 \text{ W ; Output} = 11.19 \text{ kW} = 11,190 \text{ W}$$

$$\therefore \text{Rotational losses} = 11,650 - 11,190 = \mathbf{460 \text{ W}}$$

$$(e) \quad \text{Total motor input} = VI = 240 \times 51 = 12,340 \text{ W ; Motor output} = 11,190 \text{ W}$$

$$\therefore \text{Efficiency} = \frac{11,190}{12,340} \times 100 = \mathbf{91.4 \%}$$

Example 29.17. A 460-V series motor runs at 500 r.p.m. taking a current of 40 A. Calculate the speed and percentage change in torque if the load is reduced so that the motor is taking 30 A. Total resistance of the armature and field circuits is 0.8 Ω. Assume flux is proportional to the field current.

(Elect. Engg.-II, Kerala Univ. 1988)

Solution. Since $\Phi \propto I_a$, hence $T \propto I_a^2$

$$\therefore T_1 \propto 40^2 \text{ and } T_2 \propto 30^2 \quad \therefore \frac{T_2}{T_1} = \frac{9}{16}$$

\therefore Percentage change in torque is

$$= \frac{T_1 - T_2}{T_1} \times 100 = \frac{7}{16} \times 100 = \mathbf{43.75 \%}$$

$$\text{Now } E_{b1} = 460 - (40 \times 0.8) = 428 \text{ V ; } E_{b2} = 460 - (30 \times 0.8) = 436 \text{ V}$$

$$\frac{N_2}{N_1} = \frac{E_{b2}}{E_{b1}} \times \frac{I_{a1}}{I_{a2}} \quad \therefore \frac{N_2}{500} = \frac{436}{428} \times \frac{40}{30} \quad \therefore N_2 = \mathbf{679 \text{ r.p.m.}}$$

Example 29.18. A 460-V, 55.95 kW, 750 r.p.m. shunt motor drives a load having a moment of inertia of 252.8 kg-m^2 . Find approximate time to attain full speed when starting from rest against full-load torque if starting current varies between 1.4 and 1.8 times full-load current.

Solution. Let us suppose that the starting current has a steady value of $(1.4 + 1.8)/2 = 1.6$ times full-load value.

$$\text{Full-load output} = 55.95 \text{ kW} = 55,950 \text{ W} ; \text{ Speed} = 750 \text{ r.p.m.} = 12.5 \text{ r.p.s.}$$

$$\text{F.L. shaft torque } T = \text{power}/\omega = \text{power}/2\pi N = 55,950 / \pi \times (750/60) = 712.4 \text{ N-m}$$

During starting period, average available torque

$$= 1.6 T - T = 0.6 T = 0.6 \times 712.4 = 427.34 \text{ N-m}$$

This torque acts on the moment of inertia $I = 252.8 \text{ kg-m}^2$.

$$\therefore 427.4 = 252.8 \times \frac{d\omega}{dt} = 252.8 \times \frac{2\pi \times 12.5}{dt}, \quad \therefore dt = 46.4 \text{ s}$$

Example 29.19. A 14.92 kW, 400 V, 400 r.p.m. d.c. shunt motor draws a current of 40 A when running at full-load. The moment of inertia of the rotating system is 7.5 kg-m^2 . If the starting current is 1.2 times full-load current, calculate

(a) full-load torque

(b) the time required for the motor to attain the rated speed against full-load.

(Electrical Technology, Gujarat Univ. 1988)

Solution. (a) F.L. output $14.92 \text{ kW} = 14,920 \text{ W}$; Speed = 400 r.p.m. = $20/3$ r.p.s

$$\text{Now, } T\omega = \text{output} \therefore T = 14,920 / 2\pi \times (20/3) = 356 \text{ N-m}$$

(b) During the starting period, the torque available for accelerating the motor armature is

$$= 1.2 T - T = 0.2 T = 0.2 \times 356 = 71.2 \text{ N-m}$$

$$\text{Now, torque} = I \frac{d\omega}{dt} \quad \therefore 71.2 = 7.5 \times \frac{2\pi \times (20/3)}{dt} \quad \therefore dt = 4.41 \text{ second}$$

29.9. Speed of a D.C. Motor

From the voltage equation of a motor (Art. 27.4), we get

$$E_b = V - I_a R_a \quad \text{or} \quad \frac{\Phi Z N}{60} \left(\frac{P}{A} \right) = V - I_a R_a$$

$$\therefore N = \frac{V - I_a R_a}{\Phi} \times \left(\frac{60A}{ZP} \right) \text{ r.p.m.}$$

$$\text{Now} \quad V - I_a R_a = E_b \quad \therefore N = \frac{E_b}{\Phi} \times \left(\frac{60A}{ZP} \right) \text{ r.p.m. or } N = K \frac{E_b}{\Phi}$$

It shows that speed is directly proportional to back e.m.f. E_b and inversely to the flux Φ on $N \propto E_b/\Phi$.

For Series Motor

Let $N_1 =$ Speed in the 1st case ; $I_{a1} =$ armature current in the 1st case

$\Phi_1 =$ flux/pole in the first case

$N_2, I_{a2}, \Phi_2 =$ corresponding quantities in the 2nd case.

Then, using the above relation, we get

$$N_1 \propto \frac{E_{b1}}{\Phi_1} \quad \text{where } E_{b1} = V - I_{a1} R_a ; N_2 \propto \frac{E_{b2}}{\Phi_2} \quad \text{where } E_{b2} = V - I_{a2} R_a$$

$$\therefore \frac{N_2}{N_1} = \frac{E_{b2}}{E_{b1}} \times \frac{\Phi_1}{\Phi_2}$$

$$\text{Prior to saturation of magnetic poles ; } \Phi \propto I_a \quad \therefore \frac{N_2}{N_1} = \frac{E_{b2}}{E_{b1}} \times \frac{I_{a1}}{I_{a2}}$$

For Shunt Motor

In this case the same equation applies,

$$i.e., \quad \frac{N_2}{N_1} = \frac{E_{b2}}{E_{b1}} \times \frac{\Phi_1}{\Phi_2} \quad \text{If } \Phi_2 = \Phi_1, \text{ then } \frac{N_2}{N_1} = \frac{E_{b2}}{E_{b1}}.$$

29.10. Speed Regulation

The term speed regulation refers to the change in speed of a motor with change in applied load torque, other conditions remaining constant. By change in speed here is meant the change which occurs under these conditions due to inherent properties of the motor itself and not those changes which are affected through manipulation of rheostats or other speed-controlling devices.

The speed regulation is defined *as the change in speed when the load on the motor is reduced from rated value to zero, expressed as percent of the rated load speed.*

$$\therefore \quad \% \text{ speed regulation} = \frac{\text{N.L. speed} - \text{F.L. speed}}{\text{F.L. speed}} \times 100 = \frac{dN}{N} \times 100$$

29.11. Torque and Speed of a D.C. Motor

It will be proved that though torque of a motor is admittedly a function of flux and armature current, *yet it is independent of speed*. In fact, it is the speed which depends on torque and not *vice-versa*. It has been proved earlier that

$$N = K \frac{V - I_a R_a}{\phi} = \frac{KE_b}{\Phi} \quad \dots \text{Art. 27.9}$$

$$\text{Also,} \quad T_a \propto \Phi I_a \quad \dots \text{Art. 27.7}$$

It is seen from above that increase in flux would decrease the speed but increase the armature torque. It cannot be so because torque always tends to produce rotation. If torque increases, motor speed must *increase* rather than *decrease*. The apparent inconsistency between the above two equations can be reconciled in the following way :

Suppose that the flux of a motor is decreased by decreasing the field current. Then, following sequence of events take place :

1. Back e.m.f. $E_b (= N\Phi/K)$ drops instantly (the speed remains constant because of inertia of the heavy armature).
2. Due to decrease in E_b , I_a is increased because $I_a = (V - E_b)/R_a$. Moreover, a small reduction in flux produces a proportionately large increase in armature current.
3. Hence, the equation $T_a \propto \Phi I_a$, a small decrease in ϕ is more than counterbalanced by a *large* increase in I_a with the result that there is a net *increase* in T_a .
4. This increase in T_a produces an increase in motor speed.

It is seen from above that with the applied voltage V held constant, motor speed varies inversely as the flux. However, it is possible to increase flux and, at the same time, increase the speed provided I_a is held constant as is actually done in a d.c. servomotor.

Example 29.20. A 4-pole series motor has 944 wave-connected armature conductors. At a certain load, the flux per pole is 34.6 mWb and the total mechanical torque developed is 209 N-m. Calculate the line current taken by the motor and the speed at which it will run with an applied voltage of 500 V. Total motor resistance is 3 ohm.

(Elect. Engg. AMIETE Sec. A Part II June 1991)

$$\begin{aligned} \text{Solution.} \quad T_a &= 0.159 \phi Z I_a \text{ (P/A) N-m} \\ \therefore 209 &= 0.159 \times 34.6 \times 10^{-3} \times 944 \times I_a (4/2); I_a = 20.1 \text{ A} \\ E_a &= V - I_a R_a = 500 - 20.1 \times 3 = 439.7 \text{ V} \end{aligned}$$

Now, speed may be found either by using the relation for E_b or T_a as given in Art.

$$E_b = \Phi ZN \times (P/A) \text{ or } 439.7 = 34.6 \times 10^{-3} \times 944 \times N \times 2$$

$$\therefore N = 6.73 \text{ r.p.s. or } \mathbf{382.2 \text{ r.p.m.}}$$

Example 29.21. A 250-V shunt motor runs at 1000 r.p.m. at no-load and takes 8A. The total armature and shunt field resistances are respectively 0.2 Ω and 250 Ω . Calculate the speed when loaded and taking 50 A. Assume the flux to be constant. (Elect. Engg. A.M.Ae. S.I. June 1991)

Solution. Formula used : $\frac{N}{N_0} = \frac{E_b}{E_{b0}} \times \frac{\Phi_0}{\Phi}$; Since $\Phi_0 = \Phi$ (given); $\frac{N}{N_0} = \frac{E_b}{E_{b0}}$

$$I_{sh} = 250/250 = 1 \text{ A}$$

$$E_{b0} = V - I_{a0} R_a = 250 - (7 \times 0.2) = 248.6 \text{ V}; E_b = V - I_a R_a = 250 - (49 \times 0.2) = 240.2 \text{ V}$$

$$\therefore \frac{N}{1000} = \frac{240.2}{248.6}; N = \mathbf{9666.1 \text{ r.p.m.}}$$

Example 29.22. A d.c. series motor operates at 800 r.p.m. with a line current of 100 A from 230-V mains. Its armature circuit resistance is 0.15 Ω and its field resistance 0.1 Ω . Find the speed at which the motor runs at a line current of 25 A, assuming that the flux at this current is 45 per cent of the flux at 100 A. (Electrical Machinery - I, Bangalore Univ. 1986)

Solution. $\frac{N_2}{N_1} = \frac{E_{b2}}{E_{b1}} \times \frac{\Phi_1}{\Phi_2}$; $\Phi_2 = 0.45 \Phi_1$ or $\frac{\Phi_1}{\Phi_2} = \frac{1}{0.45}$

$$E_{b1} = 230 - (0.15 + 0.1) \times 100 = 205 \text{ V}; E_{b2} = 230 - 25 \times 0.25 = 223.75 \text{ V}$$

$$\frac{N_2}{800} = \frac{223.75}{205} \times \frac{1}{0.45}; N_2 = \mathbf{1940 \text{ r.p.m.}}$$

Example 29.23. A 230-V d.c. shunt motor has an armature resistance of 0.5 Ω and field resistance of 115 Ω . At no load, the speed is 1,200 r.p.m. and the armature current 2.5 A. On application of rated load, the speed drops to 1,120 r.p.m. Determine the line current and power input when the motor delivers rated load. (Elect. Technology, Kerala Univ. 1988)

Solution. $N_1 = 1200 \text{ r.p.m.}, E_{b1} = 230 - (0.5 \times 2.5) = 228.75 \text{ V}$

$$N_2 = 1120 \text{ r.p.m.}, E_{b2} = 230 - 0.5 I_{a2}$$

Now, $\frac{N_2}{N_1} = \frac{E_{b2}}{E_{b1}} \therefore \frac{1120}{1200} = \frac{230 - 0.5 I_{a2}}{228.75}; I_{a2} = \mathbf{33 \text{ A}}$

Line current drawn by motor = $I_{a2} + I_{sh} = 33 + (230/115) = \mathbf{35 \text{ A}}$

Power input at rated load = $230 \times 35 = \mathbf{8,050 \text{ W}}$

Example 29.24. A belt-driven 100-kW, shunt generator running at 300 r.p.m. on 220-V bus-bars continues to run as a motor when the belt breaks, then taking 10 kW. What will be its speed? Given armature resistance = 0.025 Ω , field resistance = 60 Ω and contact drop under each brush = 1 V, Ignore armature reaction. (Elect. Machines (E-3) AMIE Sec.C Winter 1991)

Solution. As Generator [Fig. 29.12 (a)]

Load current, $I = 100,000/220 = 454.55 \text{ A}; I_{sh} = 220/60 = 3.67 \text{ A}$

$$I_a = I + I_{sh} = 458.2 \text{ A}; I_a R_a = 458.2 \times 0.025 = 11.45$$

$$E_b = 220 + 11.45 + 2 \times 1 = 233.45 \text{ V}; N_1 = 300 \text{ r.p.m.}$$

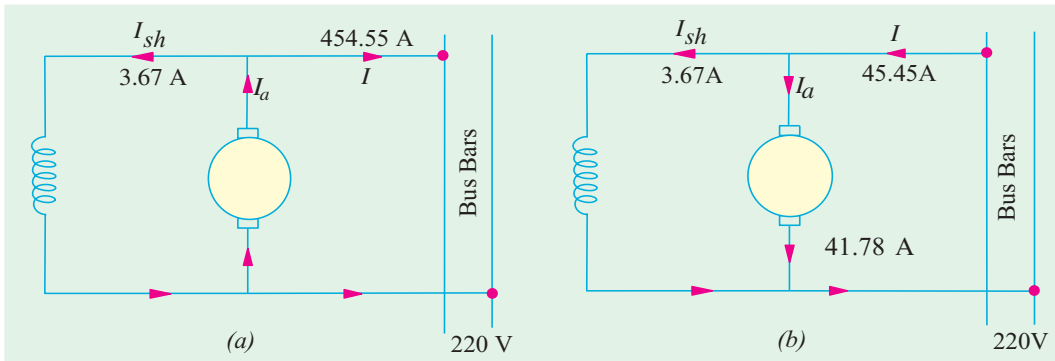

Fig. 29.12

As Motor [Fig. 29.12 (b)]

$$\begin{aligned} \text{Input line current} &= 100,000/220 = 45.45 \text{ A}; I_{sh} = 220/60 = 3.67 \text{ A} \\ I_a &= 45.45 - 3.67 = 41.78 \text{ A}; I_a R_a = 41.78 \times 0.025 = 1.04 \text{ V}; E_{b2} = 220 - 1.04 - 2 \times 1 = 216.96 \text{ V} \\ \frac{N_2}{N_1} &= \frac{E_{b2}}{E_{b1}} \times \frac{\Phi_1}{\Phi_2}; \text{ since } \Phi_1 = \Phi_2 \text{ because } I_{sh} \text{ is constant} \\ \therefore \frac{N_2}{300} &= \frac{216.96}{233.45}; N_2 = 279 \text{ r.p.m.} \end{aligned}$$

Example 29.25. A d.c. shunt machine generates 250-V on open circuit at 1000 r.p.m. Effective armature resistance is 0.5 Ω, field resistance is 250 Ω, input to machine running as a motor on no-load is 4 A at 250 V. Calculate speed of machine as a motor taking 40 A at 250 V. Armature reaction weakens field by 4%. **(Electrical Machines-I, Gujarat Univ. 1987)**

Solution. Consider the case when the machine runs as a motor on no-load.

$$\text{Now, } I_{sh} = 250/250 = 1 \text{ A}; \text{ Hence, } I_{a0} = 4 - 1 = 3 \text{ A}; E_{b0} = 250 - 0.5 \times 3 = 248.5 \text{ V}$$

It is given that when armature runs at 1000 r.p.m., it generates 250 V. When it generates 248.5 V, it must be running at a speed = $1000 \times 248.5/250 = 994$ r.p.m.

$$\text{Hence, } N_0 = 994 \text{ r.p.m.}$$

When Loaded

$$I_a = 40 - 1 = 39 \text{ A}; E_b = 250 - 39 \times 0.5 = 230.5 \text{ V} \text{ Also, } \Phi_0/\Phi = 1/0.96$$

$$\frac{N}{E} = \frac{E_b}{E_{b0}} \therefore \frac{N}{994} = \frac{230.5}{248.5} \times \frac{1}{0.96} \quad N = 960 \text{ r.p.m.}$$

Example 29.26. A 250-V shunt motor giving 14.92 kW at 1000 r.p.m. takes an armature current of 75 A. The armature resistance is 0.25 ohm and the load torque remains constant. If the flux is reduced by 20 percent of its normal value before the speed changes, find the instantaneous value of the armature current and the torque. Determine the final value of the armature current and speed. **(Elect. Engg. AMIETE (New Scheme) 1990)**

Solution. $E_{b1} = 250 - 75 \times 0.25 = 231.25 \text{ V}$, as in Fig. 29.13.

When flux is reduced by 20%, the back e.m.f. is also reduced instantly by 20% because speed remains constant due to inertia of the heavy armature (Art. 29.11).

$$\therefore \text{Instantaneous value of back e.m.f. } (E_b)_{inst} = 231.25 \times 0.8 = 185 \text{ V}$$

$$(I_a)_{inst} = [V - (E_b)_{inst}]/R_a = (250 - 185)/0.25 = 260 \text{ A}$$

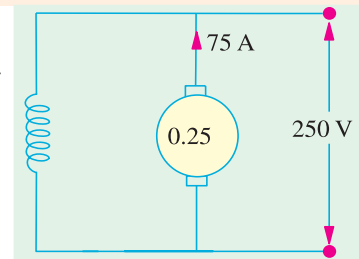

Fig. 29.13

$$\text{Instantaneous value of the torque} = 9.55 \times \frac{(E_b)_{inst} \times (I_a)_{inst}}{N \text{ (in r.p.m.)}}$$

or $(T_a)_{inst} = 9.55 \times 185 \times 260/1000 = 459 \text{ N-m}$

Steady Conditions

Since torque remains constant, $\Phi_1 I_{a1} = \Phi_2 I_{a2}$

$$I_{a2} = \Phi_1 I_{a1} / \Phi_2 = 75 \times \Phi_1 / 0.8 \Phi_1 = \mathbf{93.7 \text{ A}}$$

$\therefore E_{b2} = 250 - 93.7 \times 0.25 = 226.6 \text{ V}$

Now, $\frac{N_2}{N_1} = \frac{E_{b2}}{E_{b1}} \times \frac{\Phi_1}{\Phi_2} = \frac{226.6}{231.25} \times \frac{1}{0.8}; N_2 = 1225 \text{ r.p.m.}$

Example 29.27. A 220-V, d.c. shunt motor takes 4 A at no-load when running at 700 r.p.m. The field resistance is 100 Ω. The resistance of armature at standstill gives a drop of 6 volts across armature terminals when 10 A were passed through it. Calculate (a) speed on load (b) torque in N-m and (c) efficiency. The normal input of the motor is 8 kW.

(Electrotechnics-II; M.S. Univ. Baroda 1988)

Solution. (a) $I_{sh} = 200/100 = 2 \text{ A}$

F.L. Power input = 8,000 W; F.L. line current = 8,000/200 = 40 A

$$I_a = 40 - 2 = 38 \text{ A}; R_a = 6/10 = 0.6 \Omega$$

$$E_{b0} = 200 - 2 \times 0.6 = 198.8 \text{ V}; E_b = 200 - 38 \times 0.6 = 177.2 \text{ V}$$

Now, $\frac{N}{N_0} = \frac{E_b}{E_{b0}}$ or $\frac{N}{700} = \frac{177.2}{198.8}; N = \mathbf{623.9 \text{ r.p.m.}}$

(b) $T_a = 9.55 E_b I_a / N = 9.55 \times 177.2 \times 38 / 623.9 = \mathbf{103 \text{ N-m}}$

(c) N.L. power input = 200 × 4 = 800 W; Arm. Cu loss = $I_a^2 R_a = 2^2 \times 0.6 = 2.4 \text{ W}$

Constant losses = 800 - 2.4 = 797.6 W; F.L. arm. Cu loss = $38^2 \times 0.6 = 866.4 \text{ W}$

Total F.L. losses = 797.6 + 866.4 = 1664 W; F.L. output = 8,000 - 1664 = 6336 W

F.L. Motor efficiency = 6336/8,000 = 0.792 or **79.2 %**

Example 29.28. The input to 230-V, d.c. shunt motor is 11kW. Calculate (a) the torque developed (b) the efficiency (c) the speed at this load. The particulars of the motor are as follows :

No-load current = 5 A; No-load speed = 1150 r.p.m.

Arm. resistance = 0.5 Ω; shunt field resistance = 110 Ω.

(Elect. Technology ; Bombay University 1988)

Solution. No-load input = 220 × 5 = 1,100 W; $I_{sh} = 220/110 = 2\text{A}; I_{ao} = 5 - 2 = 3\text{A}$

No-load armature Cu loss = $3^2 \times 0.5 = 4.5 \text{ W}$

\therefore Constant losses = 1,100 - 4.5 = 1,095.5 W

When input is 11 kW.

Input current = 11,000/220 = 50A ; Armature current = 50 - 2 = **48 A**

Arm. Cu loss = $48^2 \times 0.5 = 1,152 \text{ W};$

Total loss = Arm. Cu loss + Constant losses = 1152 + 1095.5 = 2248 W

Output = 11,000 - 2,248 = 8,752 W

(b) Efficiency = $8,752 \times 100 / 11,000 = \mathbf{79.6\%}$

(c) Back e.m.f. at no-load = 220 - (3 × 0.5) = 218.5 V

Back e.m.f. at given load = 220 - (48 × 0.5) = 196 V

\therefore Speed $N = 1,150 \times 196 / 218.5 = \mathbf{1,031 \text{ r.p.m.}}$

(a)
$$T_a = 9.55 \times \frac{196 \times 48}{1031} = 87.1 \text{ N-m}$$

Example 29.29. The armature circuit resistance of a 18.65 kW 250-V series motor is 0.1 Ω, the brush voltage drop is 3V, and the series field resistance is 0.05. When the motor takes 80 A, speed is 600 r.p.m. Calculate the speed when the current is 100 A.

(Elect. Machines, A.M.I.E. Sec. B, 1993)

Solution.

$$E_{b1} = 250 - 80(0.1 + 0.05) - 3 = 235 \text{ V}$$

$$E_{b2} = 250 - 100(0.1 + 0.05) - 3 = 232 \text{ V}$$

Since $\Phi \propto I_a$, hence, $\Phi_1 \propto 80$, $\Phi_2 \propto 100$, $\Phi_1/\Phi_2 = 80/100$

Now
$$\frac{N_2}{N_1} = \frac{E_{b2}}{E_{b1}} \times \frac{\Phi_1}{\Phi_2} \text{ or } \frac{N_2}{600} = \frac{232}{235} \times \frac{80}{100}; N_2 = 474 \text{ r.p.m.}$$

Example 29.30. A 220-volt d.c. series motor is running at a speed of 800 r.p.m. and draws 100 A. Calculate at what speed the motor will run when developing half the torque. Total resistance of the armature and field is 0.1 ohm. Assume that the magnetic circuit is unsaturated.

(Elect. Machines ; A.M.I.E. Sec. B, 1991)

Solution.

$$\frac{N_2}{N_1} = \frac{E_{b2}}{E_{b1}} \times \frac{\Phi_1}{\Phi_2} = \frac{E_{b2}}{E_{b1}} \times \frac{I_{a1}}{I_{a2}} \quad (\because \Phi \propto I_a)$$

Since field is unsaturated, $T_a \propto \Phi I_a \propto I_a^2$. $(\because T_1 \propto I_{a1}^2 \text{ and } T_2 \propto I_{a2}^2)$

or
$$T_2/T_1 = (I_{a2}/I_{a1})^2 \text{ or } 1/2 = (I_{a2}/I_{a1})^2; I_{a1} = I_{a2}/\sqrt{2} = 70.7 \text{ A}$$

$$E_{b1} = 220 - 100 \times 0.1 = 210 \text{ V}; E_{b2} = 220 - 0.1 \times 70.7 = 212.9 \text{ V}$$

\therefore
$$\frac{N_2}{800} = \frac{212.9}{210} \times \frac{100}{70.7}; N_2 = 1147 \text{ r.p.m.}$$

Example 29.31. A 4-pole d.c. motor runs at 600 r.p.m. on full load taking 25 A at 450 V. The armature is lap-wound with 500 conductors and flux per pole is expressed by the relation.

$$\Phi = (1.7 \times 10^{-2} \times I^{0.5}) \text{ weber}$$

where I is the motor current. If supply voltage and torque are both halved, calculate the speed at which the motor will run. Ignore stray losses.

(Elect. Machines, Nagpur Univ. 1993)

Solution. Let us first find R_a

Now
$$N = \frac{E_b}{Z\Phi} \left(\frac{60 A}{P} \right) \text{ r.p.m.}$$

\therefore
$$600 = \frac{E_b}{1.7 \times 10^{-2} \times 25^{0.5}} \times \frac{60 \times 4}{500 \times 4}$$

\therefore
$$E_b = 10 \times 1.7 \times 10^{-2} \times 5 \times 500 = 425 \text{ V}$$

$$I_a R_a = 450 - 425 = 25 \text{ V}; R_a = 25/25 = 1.0 \Omega$$

Now in the Ist Case

$$T_1 \propto \Phi_1 I_1 \quad \therefore T_1 \propto 1.7 \times 10^{-2} \times \sqrt{25} \times 25$$

Similarly
$$T_2 \propto 1.7 \times 10^{-2} \times \sqrt{1 \times I}; \text{ Now } T_1 = 2T_2$$

\therefore
$$1.7 \times 10^{-2} \times 125 = 1.7 \times 10^{-2} \times I^{3/2} \times 2 \quad \therefore I = (125/2)^{2/3} = 15.75 \text{ A}$$

$$E_{b1} = 425 \text{ V}; E_{b2} = 225 - (15.75 \times 1) = 209.3 \text{ V}$$

Using the relation
$$\frac{N_2}{N_1} = \frac{E_{b2}}{E_{b1}} \times \frac{\Phi_1}{\Phi_2}; \text{ we have}$$

$$\frac{N_2}{600} = \frac{209.3}{425} \times \frac{1.7 \times 10^{-2} \times 5}{1.7 \times 10^{-2} \times \sqrt{15.75}}; \quad N_2 = 372 \text{ r.p.m.}$$

Tutorial Problems 29.2

1. Calculate the torque in newton-metre developed by a 440-V d.c. motor having an armature resistance of 0.25Ω and running at 750 r.p.m. when taking a current of 60 A. **[325 N-m]**
2. A 4-pole, lap-connected d.c. motor has 576 conductors and draws an armature current of 10 A. If the flux per pole is 0.02 Wb, calculate the armature torque developed. **[18.3 N-m]**
3. (a) A d.c. shunt machine has armature and field resistances of 0.025Ω and 80Ω respectively. When connected to constant 400-V bus-bars and driven as a generator at 450 r.p.m., it delivers 120 kW. Calculate its speed when running as a motor and absorbing 120 kW from the same bus-bars.
(b) Deduce the direction of rotation of this machine when it is working as a motor assuming a clockwise rotation as a generator. **[(a) 435 r.p.m. (b) Clockwise]**
4. The armature current of a series motor is 60 A when on full-load. If the load is adjusted to that this current decreases to 40-A, find the new torque expressed as a percentage of the full-load torque. The flux for a current of 40 A is 70% of that when current is 60 A. **[46%]**
5. A 4-pole, d.c. shunt motor has a flux per pole of 0.04 Wb and the armature is lap-wound with 720 conductors. The shunt field resistance is 240Ω and the armature resistance is 0.2Ω . Brush contact drop is 1V per brush. Determine the speed of the machine when running (a) as a motor taking 60 A and (b) as a generator supplying 120 A. The terminal voltage in each case is 480 V. **[972 r.p.m. ; 1055 r.p.m.]**
6. A 25-kW shunt generator is delivering full output to 400-V bus-bars and is driven at 950 r.p.m. by belt drive. The belt breaks suddenly but the machine continues to run as a motor taking 25 kW from the bus-bars. At what speed does it run? Take armature resistance including brush contact resistance as 0.5Ω and field resistance as 160Ω . **[812.7 r.p.m.] (Elect. Technology, Andhra Univ. Apr. 1977)**
7. A 4-pole, d.c. shunt motor has a wave-wound armature with 65 slots each containing 6 conductors. The flux per pole is 20 mWb and the armature has a resistance of 0.15Ω . Calculate the motor speed when the machine is operating from a 250-V supply and taking a current of 60 A. **[927 r.p.m.]**
8. A 500-V, d.c. shunt motor has armature and field resistances of 0.5Ω and 200Ω respectively. When loaded and taking a total input of 25 kW, it runs at 400 r.p.m. Find the speed at which it must be driven as a shunt generator to supply a power output of 25 kW at a terminal voltage of 500 V. **[442 r.p.m.]**
9. A d.c. shunt motor runs at 900 r.p.m. from a 400 V supply when taking an armature current of 25 A. Calculate the speed at which it will run from a 230 V supply when taking an armature current of 15 A. The resistance of the armature circuit is 0.8Ω . Assume the flux per pole at 230 V to have decreased to 75% of its value at 400 V. **[595 r.p.m.]**
10. A shunt machine connected to 250-A mains has an armature resistance of 0.12Ω and field resistance of 100Ω . Find the ratio of the speed of the machine as a generator to the speed as a motor, if line current is 80 A in both cases. **[1.08] (Electrical Engineering-II, Bombay Univ. April. 1977, Madras Univ. Nov. 1978)**
11. A 20-kW d.c. shunt generator delivering rated output at 1000 r.p.m. has a terminal voltage of 500 V. The armature resistance is 0.1Ω , voltage drop per brush is 1 volt and the field resistance is 500Ω . Calculate the speed at which the machine will run as a motor taking an input of 20 kW from a 500 V d.c. supply. **[976.1 r.p.m.] (Elect. Engg-I Bombay Univ. 1975)**
12. A 4-pole, 250-V, d.c. shunt motor has a lap-connected armature with 960 conductors. The flux per pole is 2×10^{-2} Wb. Calculate the torque developed by the armature and the useful torque in newton-metre when the current taken by the motor is 30A. The armature resistance is 0.12 ohm and the field resistance is 125Ω . The rotational losses amount to 825 W. **[85.5 N-m ; 75.3 N-m] (Electric Machinery-I, Madras Univ. Nov. 1979)**

29.12. Motor Characteristics

The characteristic curves of a motor are those curves which show relationships between the following quantities.

1. **Torque and armature current** *i.e.* T_a/I_a characteristic. It is known as **electrical characteristic**.
2. **Speed and armature current** *i.e.* N/I_a characteristic.
3. **Speed and torque** *i.e.* N/T_a characteristic. It is also known as **mechanical characteristic**. It can be found from (1) and (2) above.

While discussing motor characteristics, the following two relations should always be kept in mind :

$$T_a \propto \Phi I_a \quad \text{and} \quad N \propto \frac{E_b}{\Phi}$$

29.13. Characteristics of Series Motors

1. **T_a/I_a Characteristic.** We have seen that $T_a \propto \Phi I_a$. In this case, as field windings also carry the armature current, $\Phi \propto I_a$ up to the point of magnetic saturation. Hence, before saturation,

$$T_a \propto \Phi I_a \quad \text{and} \quad \therefore T_a \propto I_a^2$$

At light loads, I_a and hence Φ is small. But as I_a increases, T_a increases as the square of the current. Hence, T_a/I_a curve is a parabola as shown in Fig. 29.14. After saturation, Φ is almost independent of I_a hence $T_a \propto I_a$ only. So the characteristic becomes a straight line. The shaft torque T_{sh} is less than armature torque due to stray losses. It is shown dotted in the figure. So we conclude that (prior to magnetic saturation) on heavy loads, a series motor exerts a torque proportional to the square of armature current. Hence, in cases where huge starting torque is required for accelerating heavy masses quickly as in hoists and electric trains etc., series motors are used.

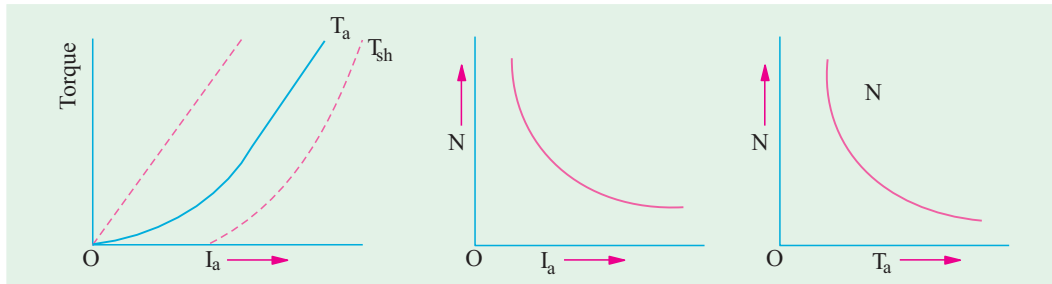

Fig. 29.14

Fig. 29.15

Fig. 29.16

2. **N/I_a Characteristics.** Variations of speed can be deduced from the formula :

$$N \propto \frac{E_b}{\Phi}$$

Change in E_b , for various load currents is small and hence may be neglected for the time being. With increased I_a , Φ also increases. Hence, speed varies inversely as armature current as shown in Fig. 29.15.

When load is heavy, I_a is large. Hence, speed is low (this decreases E_b and allows more armature current to flow). But when load current and hence I_a falls to a small value, speed becomes dangerously high. Hence, a series motor should never be started without some mechanical (not belt-driven) load on it otherwise it may develop excessive speed and get damaged due to heavy centrifugal forces so produced. It should be noted that series motor is a variable speed motor.

3. **N/T_a or mechanical characteristic.** It is found from above that when speed is high, torque is low and **vice-versa**. The relation between the two is as shown in Fig. 29.16.

29.14. Characteristics of Shunt Motors

1. T_a/I_a Characteristic

Assuming Φ to be practically constant (though at heavy loads, ϕ decreases somewhat due to increased armature reaction) we find that $T_a \propto I_a$.

Hence, the electrical characteristic as shown in Fig. 29.17, is practically a straight line through the origin. Shaft torque is shown dotted. Since a heavy starting load will need a heavy starting current, shunt motor should never be started on (heavy) load.

2. N/I_a Characteristic

If Φ is assumed constant, then $N \propto E_b$. As E_b is also practically constant, speed is, for most purposes, constant (Fig. 29.18).

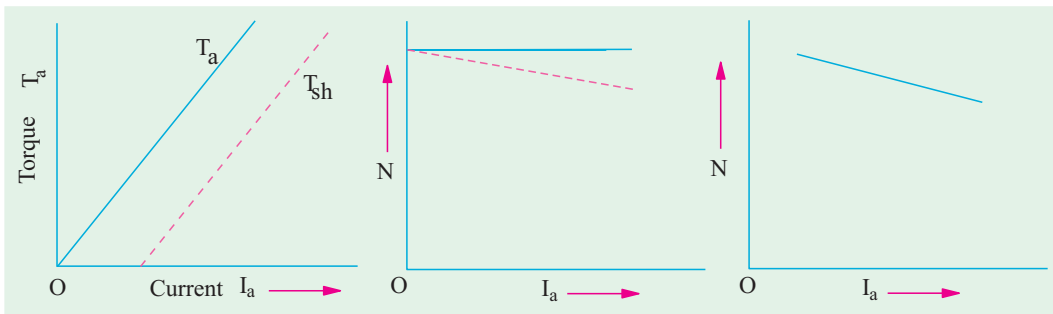

Fig. 29.17

Fig. 29.18

Fig. 29.19

But strictly speaking, both E_b and Φ decrease with increasing load. However, E_b decreases slightly more than ϕ so that on the whole, there is some decrease in speed. The drop varies from 5 to 15% of full-load speed, being dependent on saturation, armature reaction and brush position. Hence, the actual speed curve is slightly drooping as shown by the dotted line in Fig. 29.18. But, for all practical purposes, shunt motor is taken as a constant-speed motor.

Because there is no appreciable change in the speed of a shunt motor from no-load to full-load, it may be connected to loads which are totally and suddenly thrown off without any fear of excessive speed resulting. Due to the constancy of their speed, shunt motors are suitable for driving shafting, machine tools, lathes, wood-working machines and for all other purposes where an approximately constant speed is required.

3. N/T_a Characteristic can be deduced from (1) and (2) above and is shown in Fig. 29.19.

29.15. Compound Motors

These motors have both series and shunt windings. If series excitation helps the shunt excitation *i.e.* series flux is in the **same** direction (Fig. 29.20); then the motor is said to be cumulatively compounded. If on the other hand, series field opposes the shunt field, then the motor is said to be differentially compounded.

The characteristics of such motors lie in between those of shunt and series motors as shown in Fig. 29.21.

(a) Cumulative-compound Motors

Such machines are used where series characteristics are required and where, in addition,

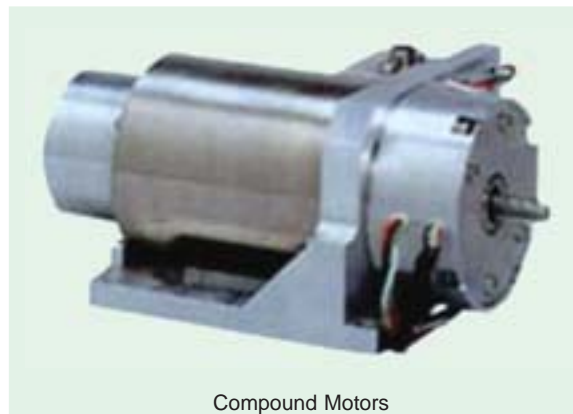

Compound Motors

the load is likely to be removed totally such as in some types of coal cutting machines or for driving heavy machine tools which have to take sudden cuts quite often. Due to shunt windings, speed will not become excessively high but due to series windings, it will be able to take heavy loads. In conjunction with fly-wheel (functioning as load equalizer), it is employed where there are sudden temporary loads as in rolling mills. The fly-wheel supplies its stored kinetic energy when motor slows down due to sudden heavy load. And when due to the removal of load motor speeds up, it gathers up its kinetic energy.

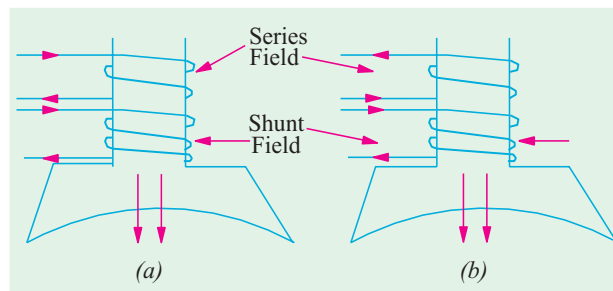

Fig. 29.20

Compound-wound motors have greatest application with loads that require high starting torques or pulsating loads (because such motors smooth out the energy demand required of a pulsating load). They are used to drive electric shovels, metal-stamping machines, reciprocating pumps, hoists and compressors etc.

(b) Differential-compound Motors

Since series field opposes the shunt field, the flux is decreased as load is applied to the motor. This results in the motor speed remaining almost constant or even increasing with increase in load (because, $N \propto E_b / (\Phi)$). Due to this reason, there is a decrease in the rate at which the motor torque increases with load. Such motors are not in common use. But because they can be designed to give an accurately constant speed under all conditions, they find limited application for experimental and research work.

One of the biggest drawback of such a motor is that due to weakening of flux with increases in load, there is a tendency towards speed instability and motor running away unless designed properly.

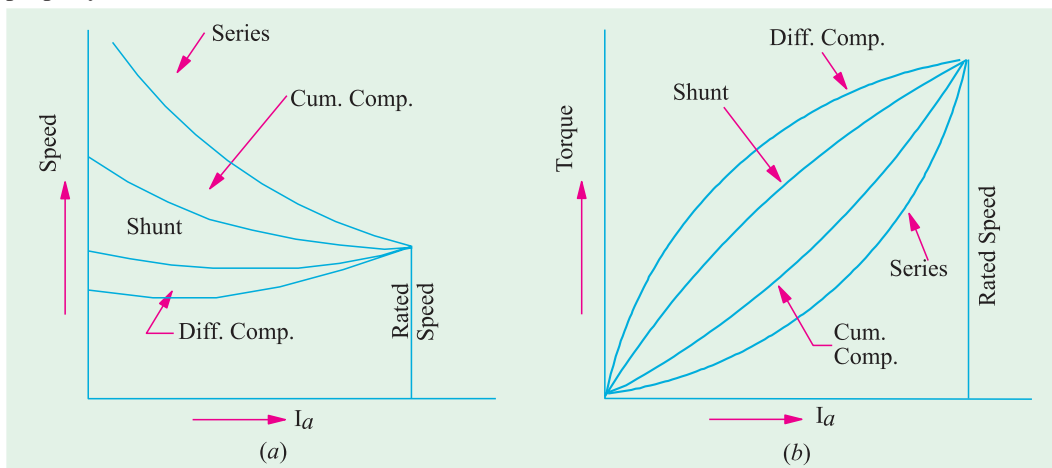

Fig. 29.21

Example 29.32. The following results were obtained from a static torque test on a series motor :

Current (A) :	20	30	40	50
Torque (N - m) :	128.8	230.5	349.8	46.2

Deduce the speed/torque curve for the machine when supplied at a constant voltage of 460 V. Resistance of armature and field winding is 0.5 Ω. Ignore iron and friction losses.

Solution. Taking the case when input current is 20 A, we have

$$\text{Motor input} = 460 \times 20 = 9,200 \text{ W}$$

$$\begin{aligned} \text{Field and armature Cu loss} \\ = 20^2 \times 0.5 = 200 \text{ W} \end{aligned}$$

Ignoring iron and friction losses,

$$\text{output} = 9,200 - 200 = 9,000 \text{ W}$$

$$\text{Now, } T_{sh} \times 2\pi N = \text{Output in watts.}$$

$$\therefore 128.8 \times 2\pi \times N = 9,000$$

$$\begin{aligned} \therefore N &= 9,000 / 2\pi \times 128.8 \\ &= 11.12 \text{ r.p.s.} = 667 \text{ r.p.m.} \end{aligned}$$

Similar calculations for other values of current are tabulated below :

Current (A)	20	30	40	50
Input (W)	9,200	13,800	18,400	23,000
I^2R loss (W)	200	450	800	1,250
Output (W)	9,200	13,350	17,600	21,850
Speed (r.p.m.)	667	551	480	445
Torque (N-m)	128.8	230.5	349.8	469.2

From these values, the speed/torque curve can be drawn as shown in Fig. 29.22.

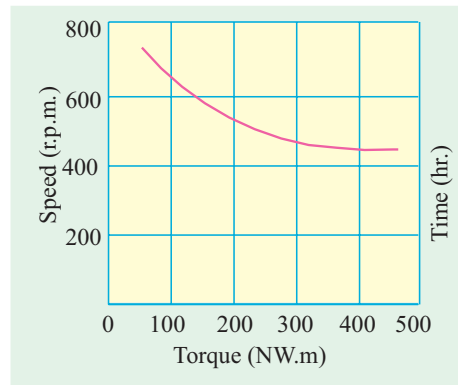

Fig. 29.22

Example 29.33. A fan which requires 8 h.p. (5.968 kW) at 700 r.p.m. is coupled directly to a d.c. series motor. Calculate the input to the motor when the supply voltage is 500 V, assuming that power required for fan varies as the cube of the speed. For the purpose of obtaining the magnetisation characteristics, the motor was running as a self-excited generator at 600 r.p.m. and the relationship between the terminal voltage and the load current was found to be as follows :

Load current (A)	:	7	10.5	14	27.5
Terminal voltage (V)	:	347	393	434	458

The resistance of both the armature and field windings of the motor is 3.5 Ω and the core, friction and other losses may be assumed to be constant at 450 W for the speeds corresponding to the above range of currents at normal voltage. **(I.E.E. London)**

Solution. Let us, by way of illustration, calculate the speed and output when motor is running off a 500-V supply and taking a current of 7A.

$$\text{Series voltage drop} = 7 \times 3.5 = 24.5 \text{ V}$$

$$\text{Generated or back e.m.f. } E_b = 500 - 24.5 = 475.5 \text{ V}$$

The motor speed is proportional to E_b for a given current. For a speed of 600 r.p.m. and a current of 7A, the generated e.m.f. is 347 V. Hence,

$$N = 600 \times 475.5 / 347 = 823 \text{ r.p.m.}$$

$$\text{Power to armature} = E_b I_a = 475.5 \times 7 = 3,329 \text{ W}$$

$$\text{Output} = \text{Armature power} - 450 = 3,329 - 450 = 2,879 \text{ W} = \mathbf{2.879 \text{ kW}}$$

$$\text{Power required by the fan at 823 r.p.m. is } = 5.968 \times 823^2 / 700^2 = 9.498 \text{ kW}$$

These calculations are repeated for the other values of current in the following table.

Input current (A)	7	10.5	14	27.5
Series drop (V)	24.5	36.7	49	96.4
Back e.m.f. (V)	475.5	463.3	451	403.6

E.M.F. at 600 r.p.m. (V)	347	393	434	458
Speed N (r.p.m.)	823	707	623	528
Armature power (W)	3329	4870	6310	11,100
Motor output (kW)	2.879	4.420	5.860	10.65
Power required by fan (kW)	9.698	6.146	4.222	2.566

In Fig. 29.23 (i) the motor output in kW and (ii) power required by fan in kW against input current is plotted. Since motor output equals the input to fan, hence the intersection point of these curves gives the value of motor input current under the given conditions.

Input current corresponding to intersection point = 12 A

\therefore Motor input = $500 \times 12 = 6,000 \text{ W}$

29.16. Performance Curves

(a) Shunt Motor

In Fig. 29.24 the four essential characteristics of a shunt motor are shown *i.e.* torque, current speed and efficiency, each plotted as a function of motor output power. These are known as the **performance curves** of a motor.

It is seen that shunt motor has a definite no-load speed. Hence, it does not ‘run away’ when load is suddenly thrown off provided the field circuit remains closed. The drop in speed from no-load to full-load is small, hence this motor is usually referred to as **constant speed** motor. The speed for any load within the operating range of the motor can be readily obtained by varying the field current by means of a field rheostat.

The efficiency curve is usually of the same shape for all electric motors and generators. The shape of efficiency curve and the point of maximum efficiency can be varied considerably by the designer, though it is advantageous to have an efficiency curve which is fairly flat, so that there is little change in efficiency between load and 25% overload and to have the maximum efficiency as near to the full load as possible.

It will be seen from the curves, that a certain value of current is required even when output is zero. The motor input under no-load conditions goes to meet the various losses occurring within the machine.

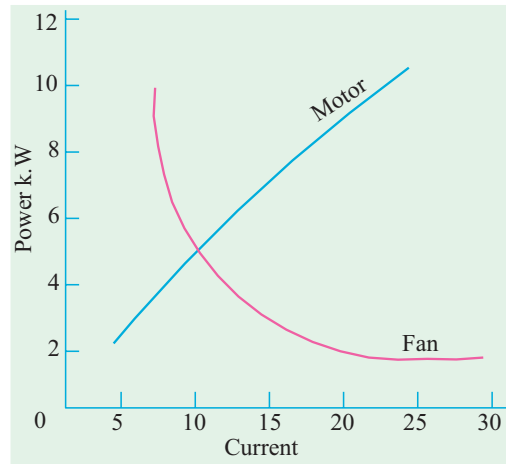

Fig. 29.23

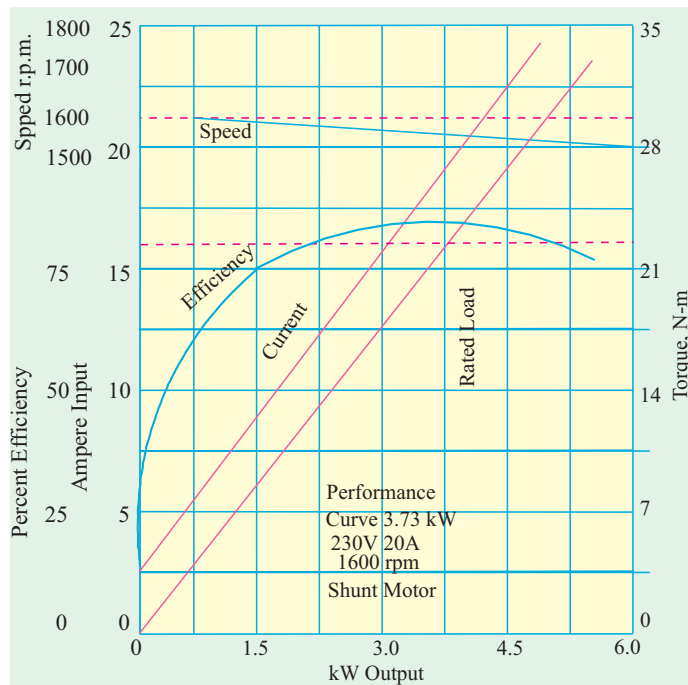

Fig. 29.24

As compared to other motors, a shunt motor is said to have a lower starting torque. But this should not be taken to mean that a shunt motor is incapable of starting a heavy load. Actually, it means that series and compound motors are capable of starting heavy loads with less excess of current inputs over normal values than the shunt motors and that consequently the depreciation on the motor will be relatively less. For example, if twice full load torque is required at start, then shunt motor draws twice the full-load current ($T_a \propto I_a$ or $I_a \propto \sqrt{T_a}$) whereas series motor draws only approximately one and a half times the full load current ($T_a \propto I_a^2$ or $I_a \propto \sqrt{T_a}$).

The shunt motor is widely used with loads that require essentially constant speed but where high starting torques are not needed. Such loads include centrifugal pumps, fans, winding reels conveyors and machine tools etc.

(b) Series Motor

The typical performance curves for a series motor are shown in Fig. 29.25.

It will be seen that drop in speed with increased load is much more prominent in series motor than in a shunt motor. Hence, a series motor is not suitable for applications requiring a substantially constant speed.

For a given current input, the starting torque developed by a series motor is greater than that developed by a shunt motor. Hence, series motors are used where huge starting torques are necessary *i.e.* for street cars, cranes, hoists and for electric-railway operation. In addition to the huge starting torque, there is another unique characteristic of series motors which makes them especially desirable for traction work *i.e.* when a load comes on a series motor, it responds by decreasing its speed (and hence, E_b) and supplies the increased torque with a small increase in current. On the other hand a shunt motor under the same conditions would hold its speed nearly constant and would supply the required increased torque with a large increase of input current. Suppose that instead of a series motor, a shunt motor is used to drive a street car. When the car ascends a grade, the shunt motor maintains the speed for the car at approximately the same value it had on the level ground, but the motor tends to take an excessive current. A series motor, however, automatically slows down on such a grade because of increased current demand, and so it develops more torque at reduced speed. The drop in speed permits the motor to develop a large torque with but a moderate increase of power. Hence, under the same load conditions, rating of the series motor would be less than for a shunt motor.

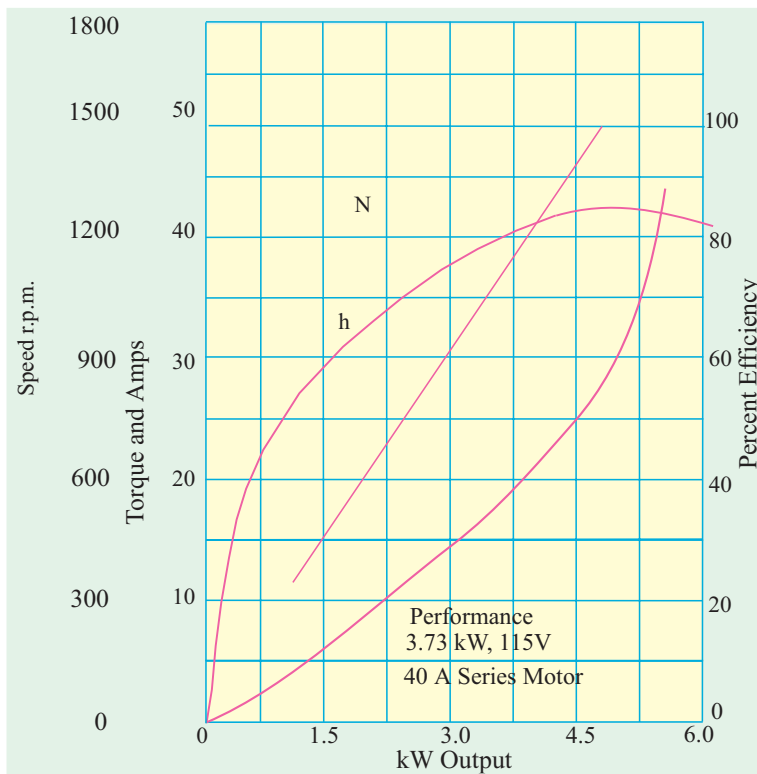

Fig. 29.25

29.17. Comparison of Shunt and Series Motors

(a) Shunt Motors

The different characteristics have been discussed in Art. 29.14. It is clear that

- (a) speed of a shunt motor is sufficiently constant.
- (b) for the same current input, its starting torque is not a high as that of series motor. Hence, it is used.
 - (i) When the speed has to be maintained approximately constant from N.L. to F.L. *i.e.* for driving a line of shafting etc.
 - (ii) When it is required to drive the load at various speeds, any one speed being kept constant for a relatively long period *i.e.* for individual driving of such machines as lathes. The shunt regulator enables the required speed control to be obtained easily and economically.



Shunt Motors

Summary of Applications

Type of motor	Characteristics	Applications
Shunt	Approximately constant speed Adjustable speed Medium starting torque (Up to 1.5 F.L. torque)	For driving constant speed line shafting Lathes Centrifugal pumps Machine tools Blowers and fans Reciprocating pumps
Series	Variable speed Adjustable varying speed High Starting torque	For traction work <i>i.e.</i> Electric locomotives Rapid transit systems Trolley, cars etc. Cranes and hoists Conveyors
Comulative Compound	Variable speed Adjustable varying speed High starting torque	For intermittent high torque loads For shears and punches Elevators Conveyors Heavy planers Heavy planers Rolling mills; Ice machines; Printing presses; Air compressors

(b) Series Motors

The operating characteristics have been discussed in Art 29.13. These motors

1. have a relatively huge starting torques.
2. have good accelerating torque.
3. have low speed at high loads and dangerously high speed at low loads.

Hence, such motors are used

1. when a large starting torque is required *i.e.* for driving hoists, cranes, trams etc.

2. when the motor can be directly coupled to a load such as a fan whose torque increases with speed.

3. if constancy of speed is not essential, then, in fact, the decrease of speed with increase of load has the advantage that the power absorbed by the motor does not increase as rapidly as the torque. For instance, when torque is doubled, the power approximately increases by about 50 to 60% only. ($\therefore I_a \propto \sqrt{T_a}$).

4. a series motor should not be used where there is a possibility of the load decreasing to a very small value. Thus, it should not be used for driving centrifugal pumps or for a belt-drive of any kind.



29.18. Losses and Efficiency

The losses taking place in the motor are the same as in generators. These are (i) Copper losses (ii) Magnetic losses and (iii) Mechanical losses.

The condition for maximum power developed by the motor is

$$I_a R_a = V/2 = E_b$$

The condition for maximum efficiency is that armature Cu losses are equal to constant losses. (Art. 26.39).

29.19. Power Stages

The various stages of energy transformation in a motor and also the various losses occurring in it are shown in the flow diagram of Fig. 29.26.

Overall or commercial efficiency $\eta_c = \frac{C}{A}$, Electrical efficiency $\eta_e = \frac{B}{A}$, Mechanical efficiency $\eta_m = \frac{C}{B}$.

The efficiency curve for a motor is similar in shape to that for a generator (Art. 24.35).

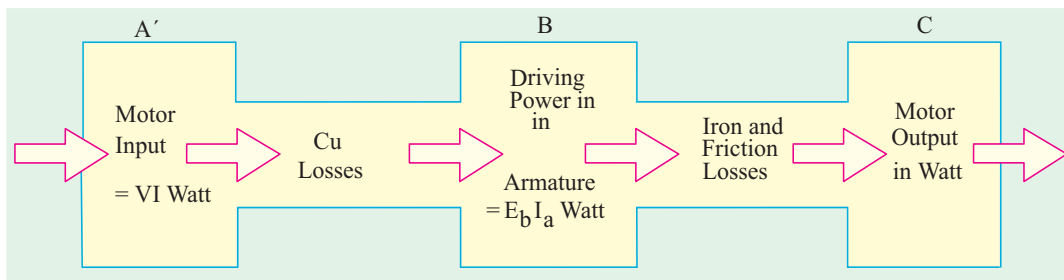

Fig. 29.26

It is seen that $A - B =$ copper losses and $B - C =$ iron and friction losses.

Example 29.34. One of the two similar 500-V shunt machines A and B running light takes 3 A. When A is mechanically coupled to B, the input to A is 3.5 A with B unexcited and 4.5 A when B is separately-excited to generate 500 V. Calculate the friction and windage loss and core loss of each machine. (Electric Machinery-I, Madras Univ. 1985)

Solution. When running light, machine input is used to meet the following losses (i) armature Cu loss (ii) shunt Cu loss (iii) iron loss and (iv) mechanical losses i.e. friction and windage losses. Obviously, these no-load losses for each machine equal $500 \times 3 = 1500$ W.

(a) With B unexcited

In this case, only mechanical losses take place in *B*, there being neither Cu loss nor iron-loss because *B* is unexcited. Since machine *A* draws 0.5 A more current.

Friction and windage loss of *B* = $500 \times 0.5 = 250 \text{ W}$

(b) With B excited

In this case, both iron losses as well as mechanical losses take place in machine *B*. Now, machine *A* draws, $4.5 - 3 = 1.5 \text{ A}$ more current.

Iron and mechanical losses of *B* = $1.5 \times 500 = 750 \text{ W}$

Iron losses of *B* = $750 - 250 = 500 \text{ W}$

Example 29.35. A 220 V shunt motor has an armature resistance of 0.2 ohm and field resistance of 110 ohm. The motor draws 5 A at 1500 r.p.m. at no load. Calculate the speed and shaft torque if the motor draws 52 A at rated voltage. **(Elect. Machines Nagpur Univ. 1993)**

Solution.

$$I_{sh} = 220/110 = 2 \text{ A}; I_{a1} = 5 - 2 = 3 \text{ A}; I_{a2} = 52 - 2 = 50 \text{ A}$$

$$E_{b1} = 220 - 3 \times 0.2 = 219.4 \text{ V}; E_{b2} = 220 - 50 \times 0.2 = 210 \text{ V}$$

$$\frac{N_2}{1500} = \frac{210}{219.4}; N_2 = 1436 \text{ r.p.m. } (\Phi_1 = \Phi_2)$$

For finding the shaft torque, we will find the motor output when it draws a current of 52 A. First we will use the no-load data for finding the constant losses of the motor.

$$\text{No load motor input} = 220 \times 5 = 1100 \text{ W}; \text{Arm. Cu loss} = 3^2 \times 0.2 = 2 \text{ W}$$

$$\therefore \text{Constant or standing losses of the motor} = 1100 - 2 = 1098$$

$$\text{When loaded, arm. Cu loss} = 50^2 \times 0.2 = 500 \text{ W}$$

$$\text{Hence, total motor losses} = 1098 + 500 = 1598 \text{ W}$$

$$\text{Motor input on load} = 220 \times 52 = 11,440 \text{ W}; \text{output} = 11,440 - 1598 = 9842 \text{ W}$$

$$\therefore T_{sh} = 9.55 \times \text{output}/N = 9.55 \times 9842/1436 = 65.5 \text{ N-m}$$

Example 29.36. 250 V shunt motor on no load runs at 1000 r.p.m. and takes 5 amperes. Armature and shunt field resistances are 0.2 and 250 ohms respectively. Calculate the speed when loaded taking a current of 50 A. The armature reaction weakens the field by 3%. **(Elect. Engg.-I Nagpur Univ. 1993)**

Solution.

$$I_{sh} = 250/250 = 1 \text{ A}; I_{a1} = 5 - 1 = 4 \text{ A}; I_{a2} = 50 - 1 = 49 \text{ A}$$

$$E_{b1} = 250 - 4 \times 0.2 = 249.2 \text{ V}; E_{b2} = 250 - 49 \times 0.2 = 240.2 \text{ V}$$

$$\frac{N_2}{1000} = \frac{240.2}{249.2} \times \frac{\Phi_1}{0.97 \Phi_1}; N_2 = 944 \text{ r.p.m.}$$

Example 29.37. A 500 V d.c. shunt motor takes a current of 5 A on no-load. The resistances of the armature and field circuit are 0.22 ohm and 250 ohm respectively. Find (a) the efficiency when loaded and taking a current of 100 A (b) the percentage change of speed. State precisely the assumptions made. **(Elect. Engg.-I, M.S. Univ. Baroda 1987)**

Solution. No-Load condition

$$I_{sh} = 500/250 = 2 \text{ A}; I_{a0} = 5 - 2 = 3 \text{ A}; E_{b0} = 500 - (3 \times 0.22) = 499.34 \text{ V}$$

$$\text{Arm. Cu loss} = 3^2 \times 0.22 = 2 \text{ W}; \text{Motor input} = 500 \times 5 = 2500 \text{ W}$$

$$\text{Constant losses} = 2500 - 2 = 2498 \text{ W}$$

It is assumed that these losses remain constant under all load conditions.

Load condition

(a) Motor current = 100 A; $I_a = 100 - 2 = 98 \text{ A}; E_b = 500 - (98 \times 0.22) = 478.44 \text{ V}$

$$\begin{aligned} \text{Arm. Cu loss} &= 98^2 \times 0.22 = 2110 \text{ W, Total losses} = 2110 + 2498 = 4608 \text{ W} \\ \text{Motor input} &= 500 \times 100 = 50,000 \text{ W, Motor output} = 50,000 - 4,608 = 45,392 \text{ W} \\ \text{Motor } \eta &= 45,392/50,000 = 0.908 \text{ or } \mathbf{90.8\%} \\ \frac{N}{N_0} &= \frac{E_b}{E_{b0}} = \frac{478.44}{499.34} \text{ or } \frac{N - N_0}{N_0} = \frac{-20.9}{499.34} = -0.0418 \text{ or } \mathbf{-4.18\%} \end{aligned}$$

Example 29.38. A 250 V d.c. shunt motor runs at 1000 r.p.m. while taking a current of 25 A. Calculate the speed when the load current is 50 A if armature reaction weakens the field by 3%. Determine torques in both cases.

$$R_a = 0.2 \text{ ohm ; } R_f = 250 \text{ ohms}$$

Voltage drop per brush is 1 V. (Elect. Machines Nagpur Univ. 1993)

Solution.

$$\begin{aligned} I_{sh} &= 250/250 = 1 \text{ A; } I_{a1} = 25 - 1 = 24 \text{ A} \\ E_{bh} &= 250 - \text{arm. drop} - \text{brush drop} \\ &= 250 - 24 \times 0.2 - 2 = 243.2 \text{ V} \\ I_{a2} &= 50 - 1 = 49 \text{ A; } E_{b2} = 250 - 49 \times 0.2 - 2 = 238.2 \text{ V} \\ \frac{N_2}{1000} &= \frac{238.2}{243.2} \times \frac{\Phi_1}{0.97 \Phi_1}; N_2 = 1010 \text{ r.p.m.} \\ T_{a1} &= 9.55 E_{b1} I_{a1}/N_1 = 9.55 \times 243.2 \times 24/1000 = 55.7 \text{ N-m} \\ T_{a2} &= 9.55 \times 238.2 \times 49/1010 = 110.4 \text{ r.p.m.} \end{aligned}$$

Example 29.39. A d.c. shunt machine while running as generator develops a voltage of 250 V at 1000 r.p.m. on no-load. It has armature resistance of 0.5 Ω and field resistance of 250 Ω. When the machine runs as motor, input to it at no-load is 4 A at 250 V. Calculate the speed and efficiency of the machine when it runs as a motor taking 40 A at 250 V. Armature reaction weakens the field by 4 %.

(Electrical Technology, Aligarh Muslim Univ. 1989)

Solution.
$$\frac{N_2}{N_1} = \frac{E_{b2}}{E_{b1}} \times \frac{\Phi_1}{\Phi_2}$$

Now, when running as a generator, the machine gives 250 V at 1000 r.p.m. If this machine was running as motor at 1000 r.p.m., it will, obviously, have a back e.m.f. of 250 V produced in its armature. Hence $N_1 = 1000$ r.p.m. and $E_{b1} = 250$ V.

When it runs as a motor, drawing 40 A, the back e.m.f. induced in its armature is

$$E_{b2} = 250 - (40 - 1) \times 0.5 = 230.5 \text{ V; Also } \Phi_2 = 0.96 \Phi_1, N_2 = ?$$

Using the above equation we have

$$\frac{N_2}{1000} = \frac{230.5}{250} \times \frac{\Phi_1}{0.96 \Phi_1}; N_2 = \mathbf{960 \text{ r.p.m.}}$$

Efficiency

No-load input represents motor losses which consists of

- (a) armature Cu loss = $I_a^2 R_a$ which is variable.
- (b) constant losses W_c which consists of (i) shunt Cu loss (ii) magnetic losses and (iii) mechanical losses.

No-load input or total losses = $250 \times 4 = 1000$ W

Arm. Cu loss = $I_a^2 R_a = 3^2 \times 0.5 = 4.5$ W, $\therefore W_c = 1000 - 4.5 = 995.5$ W

When motor draws a line current of 40 A, its armature current is $(40 - 1) = 39$ A

Arm. Cu loss = $39^2 \times 0.5 = 760.5$ W; Total losses = $760.5 + 955.5 = 1756$ W

Input = $250 \times 40 = 10,000$ W; output = $10,000 - 1756 = 8,244$ W

$\therefore \eta = 8,244 \times 100/10,000 = \mathbf{82.44\%}$

Example 29.40. The armature winding of a 4-pole, 250 V d.c. shunt motor is lap connected. There are 120 slots, each slot containing 8 conductors. The flux per pole is 20 mWb and current taken by the motor is 25 A. The resistance of armature and field circuit are 0.1 and 125 Ω respectively. If the rotational losses amount to be 810 W find,

(i) gross torque (ii) useful torque and (iii) efficiency. (Elect. Machines Nagpur Univ. 1993)

Solution. $I_{sh} = 250/125 = 2$ A; $I_a = 25 - 2 = 23$ A; $E_b = 250 - (23 \times 0.1) = 247.7$ V

$$\text{Now, } E_b = \frac{\Phi ZN}{60} \left(\frac{P}{A} \right) \quad \therefore 247.7 = \frac{20 \times 10^{-3} \times 960 \times N}{60} \left(\frac{4}{4} \right); N = 773 \text{ r.p.m.}$$

(i) Gross torque or armature torque $T_a = 9.55 \frac{E_b I_a}{N} = 9.55 \times \frac{247.7 \times 23}{773} = 70.4 \text{ N-m}$

(ii) Arm Cu loss = $23^2 \times 0.1 = 53$ W; Shunt Cu loss = $250 \times 2 = 500$ W

Rotational losses = 810 W; Total motor losses = $810 + 500 + 53 = 1363$ W

Motor input = $250 \times 25 = 6250$ W; Motor output = $6250 - 1363 = 4887$ W

$T_{sh} = 9.55 \times \text{output}/N = 9.55 \times 4887/773 = 60.4 \text{ N-m}$

(iii) Efficiency = $4887/6250 = 0.782 = 78.2\%$

Example 29.41. A 20-hp (14.92 kW); 230-V, 1150-r.p.m. 4-pole, d.c. shunt motor has a total of 620 conductors arranged in two parallel paths and yielding an armature circuit resistance of 0.2 Ω . When it delivers rated power at rated speed, it draws a line current of 74.8 A and a field current of 3 A. Calculate (i) the flux per pole (ii) the torque developed (iii) the rotational losses (iv) total losses expressed as a percentage of power. (Electrical Machinery-I, Bangalore Univ. 1987)

Solution. $I_a = 74.8 - 3 = 71.8$ A; $E_b = 230 - 71.8 \times 0.2 = 215.64$ V

(i) Now, $E_b = \frac{\Phi ZN}{60} \left(\frac{P}{A} \right); 215.64 = \frac{\Phi \times 620 \times 1150}{60} \left(\frac{4}{2} \right); \Phi = 9 \text{ mWb}$

(ii) Armature Torque, $T_a = 9.55 \times 215.64 \times 71.8/1150 = 128.8 \text{ N-m}$

(iii) Driving power in armature = $E_b I_a = 215.64 \times 71.8 = 15,483$ W

Output = 14,920 W; Rotational losses = $15,483 - 14,920 = 563$ W

(iv) Motor input = $VI = 230 \times 74.8 = 17,204$ W; Total loss = $17,204 - 14,920 = 2,284$ W

Losses expressed as percentage of power input = $2284/17,204 = 0.133$ or 13.3%

Example 29.42. A 7.46 kW, 250-V shunt motor takes a line current of 5 A when running light. Calculate the efficiency as a motor when delivering full load output, if the armature and field resistance are 0.5 Ω and 250 Ω respectively. At what output power will the efficiency be maximum? Is it possible to obtain this output from the machine? (Electrotechnics-II, M.S. Univ. Baroda 1985)

Solution. When loaded lightly

Total motor input (or total no-load losses) = $250 \times 5 = 1,250$ W

$$I_{sh} = 250/250 = 1 \text{ A} \quad \therefore I_a = 5 - 1 = 4 \text{ A}$$

$$\text{Field Cu loss} = 250 \times 1 = 250 \text{ W; Armature Cu loss} = 4^2 \times 0.5 = 8 \text{ W}$$

\therefore Iron losses and friction losses = $1250 - 250 - 8 = 992$ W

These losses would be assumed constant.

Let I_a be the full-load armature current, then armature input is = $(250 \times I_a)$ W

$$\text{F.L. output} = 7.46 \times 1000 = 7,460 \text{ W}$$

The losses in the armature are :

(i) Iron and friction losses = 992 W

(ii) Armature Cu loss = $I_a^2 \times 0.05$ W $\therefore 250 I_a = 7,460 + 992 + I_a^2 \times 0.5$

or $0.5 I_a^2 - 250 I_a + 8,452 = 0$ $\therefore I_a = 36.5 \text{ A}$
 \therefore F.L. input current = $36.5 + 1 = 37.5 \text{ A}$; Motor input = $250 \times 37.5 \text{ W}$
 F.L. output = $7,460 \text{ W}$
 \therefore F.L. efficiency = $7460 \times 100 / 250 \times 37.5 = 79.6\%$
 Now, efficiency is maximum when armature Cu loss equals constant loss.
i.e. $I_a^2 R_d = I_a^2 \times 0.5 = (1,250 - 8) = 1,242 \text{ W}$ or $I_a = 49.84 \text{ A}$
 \therefore Armature input = $250 \times 49.84 = 12,460 \text{ W}$
 Armature Cu loss = $49.84^2 \times 0.5 = 1242 \text{ W}$; Iron and friction losses = 992 W
 \therefore Armature output = $12,460 - (1,242 + 992) = 10,226 \text{ W}$
 \therefore Output power = $10,226 \text{ W} = 10.226 \text{ kW}$

As the input current for maximum efficiency is beyond the full-load motor current, it is never realised in practice.

Example 29.43. A d.c. series motor drives a load, the torque of which varies as the square of the speed. Assuming the magnetic circuit to be remain unsaturated and the motor resistance to be negligible, estimate the percentage reduction in the motor terminal voltage which will reduce the motor speed to half the value it has on full voltage. What is then the percentage fall in the motor current and efficiency? Stray losses of the motor may be ignored.

(Electrical Engineering-III, Pune Univ. 1987)

Solution. $T_a \propto \Phi I_a \propto I_a^2$. Also, $T_a \propto N^2$. Hence $N^2 \propto I_a^2$ or $N \propto I_a$

$\therefore N_1 \propto I_{a1}$ and $N_2 \propto I_{a2}$ or $N_2/N_1 = I_{a2}/I_{a1}$

Since, $N_2/N_1 = 1/2 \therefore I_{a2}/I_{a1} = 1/2$ or $I_{a2} = I_{a1}/2$

Let V_1 and V_2 be the voltages across the motor in the two cases. Since motor resistance is negligible, $E_{b1} = V_1$ and $E_{b2} = V_2$. Also $\Phi_1 \propto I_{a1}$ and $\Phi_2 \propto I_{a2}$ or $\Phi_1/\Phi_2 = I_{a1}/I_{a2} = I_{a1} \times 2/I_{a1} = 2$

Now, $\frac{N_2}{N_1} = \frac{E_{b2}}{E_{b1}} \times \frac{\Phi_1}{\Phi_2}$ or $\frac{1}{2} = \frac{V_2}{V_1} \times 2$ or $\frac{V_2}{V_1} = \frac{1}{4}$

$\therefore \frac{V_1 - V_2}{V_1} = \frac{4 - 1}{4} = 0.75$

\therefore Percentage reduction in voltage = $\frac{V_1 - V_2}{V_1} \times 100 = 0.75 \times 100 = 75\%$

Percentage change in motor current = $\frac{I_{a1} - I_{a2}}{I_{a1}} \times 100 = \frac{I_{a1} - I_{a1}/2}{I_{a1}} \times 100 = 50\%$

Example 29.44. A 6-pole, 500-V wave-connected shunt motor has 1200 armature conductors and useful flux/pole of 20 mWb. The armature and field resistance are 0.5Ω and 250Ω respectively. What will be the speed and torque developed by the motor when it draws 20 A from the supply mains? Neglect armature reaction. If magnetic and mechanical losses amount to 900 W, find (i) useful torque (ii) output in kW and (iii) efficiency at this load.

Solution. (i) $I_{sh} = 500/250 = 2 \text{ A} \therefore I_a = 20 - 2 = 18 \text{ A}$

$\therefore E_b = 500 - (18 \times 0.5) = 491 \text{ V}$; Now, $E_b = \frac{\Phi ZN}{60} \times \left(\frac{P}{A}\right)$ volt

$\therefore 491 = \frac{20 \times 10^{-3} \times 1200 \times N}{60} \times \left(\frac{6}{2}\right)$; $N = 410 \text{ r.p.m. (approx.)}$

Now $T_a = 9.55 \frac{E_b I_a}{N} = 9.55 \frac{491 \times 18}{410} = 206 \text{ N - m}$

$$\begin{aligned} \text{Armature Cu loss} &= 18^2 \times 0.5 = 162 \text{ W}; \text{ Field Cu loss} = 500 \times 2 = 1000 \text{ W} \\ \text{Iron and friction loss} &= 900 \text{ W}; \text{ Total loss} = 162 + 1000 + 900 = 2,062 \text{ W} \\ \text{Motor input} &= 500 \times 20 = 10,000 \text{ W} \end{aligned}$$

- (i) $T_{sh} = 9.55 \times \frac{7938}{410} = \mathbf{184.8 \text{ N-m}}$
 (ii) Output = 10,000 – 2062 = **7,938 kW**
 (iii) $\% \eta = \frac{\text{Output}}{\text{Input}} \times 100 = \frac{7,938 \times 100}{10,000} = 0.794 = \mathbf{79.4\%}$

Example 29.45. A 50-h.p. (37.3 kW), 460-V d.c. shunt motor running light takes a current of 4 A and runs at a speed of 660 r.p.m. The resistance of the armature circuit (including brushes) is 0.3 Ω and that of the shunt field circuit 270 Ω.

Determine when the motor is running at full load

- (i) the current input (ii) the speed. Determine the armature current at which efficiency is maximum. Ignore the effect of armature reaction. **(Elect. Technology Punjab, Univ. 1991)**

Solution. $I_{sh} = 460/270 = 1.7 \text{ A}; \text{ Field Cu loss} = 460 \times 1.7 = 783 \text{ W}$

When running light

$I_a = 4 - 1.7 = 2.3 \text{ A}; \text{ Armature Cu loss} = 2.3^2 \times 0.3 = 1.5 \text{ W (negligible)}$

No-load armature input = 460 × 2.3 = 1,058 W

As armature Cu loss is negligible, hence 1,058 W represents iron, friction and windage losses which will be assumed to be constant.

Let full-load armature input current be I_a . Then

Armature input = 460 I_a W; Armature Cu loss = $I_a^2 \times 0.3 \text{ W}$

Output = 37.3 kW = 37,300 W

$\therefore 460 I_a = 37,300 + 1,058 + 0.3 I_a^2$ or $0.3 I_a^2 - 460 I_a + 38,358 = 0$

$\therefore I_a = 88.5 \text{ A}$

(i) Current input = 88.5 + 1.7 = **90.2 A**

(ii) $E_{b1} = 460 - (2.3 \times 0.3) = 459.3 \text{ V}; E_{b2} = 460 - (88.5 \times 0.3) = 433.5 \text{ V}$

$\therefore N_2 = 660 \times 433.5/459.3 = \mathbf{624 \text{ r.p.m.}}$

For maximum efficiency, $I_a^2 R_a = \text{constant losses (Art. 24.37)}$

$\therefore I_a^2 \times 0.3 = 1058 + 783 = 1,841 \therefore I_a = (1841/0.3)^{1/2} = \mathbf{78.33 \text{ A}}$

Tutorial Problems 29.3

- A 4-pole 250-V, d.c. series motor has a wave-wound armature with 496 conductors. Calculate
 - the gross torque
 - the output torque and
 - the speed
 - the efficiency, if the motor current is 50 A

The value of flux per pole under these conditions is 22 mWb and the corresponding iron, friction and windage losses total 810 W. Armature resistance = 0.19 Ω, field resistance = 0.14 Ω.

[(a) **173.5 N-m** (b) **642 r.p.m.** (c) **161.4 N-m** (d) **86.9%**]

- On no-load, a shunt motor takes 5 A at 250 V, the resistances of the field and armature circuits are 250 Ω and 0.1 Ω respectively. Calculate the output power and efficiency of the motor when the total supply current is 81 A at the same supply voltage. State any assumptions made.

[**18.5 kW; 91%**. It is assumed that windage, friction and eddy current losses are independent of the current and speed]

3. A 230 V series motor is taking 50 A. Resistance of armature and series field windings is 0.2 Ω and 0.1 Ω respectively. Calculate :
- (a) brush voltage (b) back e.m.f.
 (c) power wasted in armature (d) mechanical power developed
- [(a) 215 V (b) 205 V (c) 500 W (d) 13.74 h.p.] (10.25 kW)
4. Calculate the shaft power of a series motor having the following data; overall efficiency 83.5%, speed 550 r.p.m. when taking 65 A; motor resistance 0.2 Ω , flux per pole 25 mWb, armature winding lap with 1200 conductor.
 (15.66 kW)
5. A shunt motor running on no-load takes 5 A at 200 V. The resistance of the field circuit is 150 Ω and of the armature 0.1 Ω . Determine the output and efficiency of motor when the input current is 120 A at 200 V. State any conditions assumed. (89.8%)
6. A d.c. shunt motor with interpoles has the following particulars :
 Output power ; 8,952 kW, 440-V, armature resistance 1.1 Ω , brush contact drop 2 V, interpole winding resistance 0.4 Ω shunt resistance 650 Ω , resistance in the shunt regulator 50 Ω . Iron and friction losses on full-load 450 W. Calculate the efficiency when taking the full rated current of 24 A.
 (85%)
7. A d.c. series motor on full-load takes 50 A from 230 V d.c. mains. The total resistance of the motor is 0.22 Ω . If the iron and friction losses together amount to 5% of the input, calculate the power delivered by the motor shaft. Total voltage drop due to the brush contact is 2 A. (10.275 kW)
8. A 2-pole d.c shunt motor operating from a 200 V supply takes a full-load current of 35 A, the no-load current being 2 A. The field resistance is 500 Ω and the armature has a resistance of 0.6 Ω . Calculate the efficiency of the motor on full-load. Take the brush drop as being equal to 1.5 V per brush arm. Neglect temperature rise.
 [Rajiv Gandhi Tech. Univ. Bhopal,2000] (82.63%)

OBJECTIVE TESTS – 29

- In a d.c. motor, unidirectional torque is produced with the help of
 (a) brushes (b) commutator
 (c) end-plates (d) both (a) and (b)
- The counter e.m.f. of a d.c. motor
 (a) often exceeds the supply voltage
 (b) aids the applied voltage
 (c) helps in energy conversion
 (d) regulates its armature voltage
- The normal value of the armature resistance of a d.c. motor is
 (a) 0.005 (b) 0.5
 (c) 10 (d) 100
 (Grad. I.E.T.E. June 1987)
- The E_b/V ratio of a d.c. motor is an indication of its
 (a) efficiency (b) speed regulation
 (c) starting torque (d) Running Torque
 (Grad. I.E.T.E. June 1987)
- The mechanical power developed by the armature of a d.c. motor is equal to
 (a) armature current multiplied by back e.m.f.
 (b) power input minus losses
 (c) power output multiplied by efficiency
 (d) power output plus iron losses
- The induced e.m.f. in the armature conductors of a d.c. motor is
 (a) sinusoidal (b) trapezoidal
 (c) rectangular (d) alternating
- A d.c. motor can be looked upon as d.c. generator with the power flow
 (a) reduced (b) reversed
 (c) increased (d) modified
- In a d.c. motor, the mechanical output power actually comes from
 (a) field system
 (b) air-gap flux
 (c) back e.m.f.
 (d) electrical input power
- The maximum torque of d.c. motors is limited by
 (a) commutation (b) heating

- (c) speed (d) armature current
10. Which of the following quantity maintains the same direction whether a d.c. machine runs as a generator or as a motor ?
(a) induced e.m.f. (b) armature current
(c) field current (d) supply current
11. Under constant load conditions, the speed of a d.c. motor is affected by
(a) field flux (b) armature current
(c) back e.m.f. (d) both (b) and (c)
12. It is possible to increase the field flux and, at the same time, increase the speed of a d.c. motor provided its is held constant.
(a) applied voltage
(b) torque
(c) Armature circuit resistance
(d) armature current
13. The current drawn by a 120 - V d.c. motor of armature resistance 0.5Ω and back e.m.f. 110 V is ampere.
(a) 20 (b) 240
(c) 220 (d) 5
14. The shaft torque of a d.c. motor is less than its armature torque because of losses.
(a) copper (b) mechanical
(c) iron (d) rotational
15. A d.c. motor develops a torque of 200 N-m at 25 rps. At 20 rps it will develop a torque of N-m.
(a) 200 (b) 160
(c) 250 (d) 128
16. Neglecting saturation, if current taken by a series motor is increased from 10 A to 12 A, the percentage increase in its torque is percent
(a) 20 (b) 44
(c) 30.5 (d) 16.6
17. If load on a d.c. shunt motor is increased, its speed is decreased due primarily to
(a) increase in its flux
(b) decrease in back e.m.f.
(c) increase in armature current
(d) increase in brush drop
18. If the load current and flux of a d.c. motor are held constant and voltage applied across its armature is increased by 10 per cent, its speed will
(a) decrease by about 10 per cent
(b) remain unchanged
(c) increase by about 10 per cent
(d) increase by 20 per cent.
19. If the pole flux of a d.c. motor approaches zero, its speed will
(a) approach zero
(b) approach infinity
(c) no change due to corresponding change in back e.m.f.
(d) approach a stable value somewhere between zero and infinity.
20. If the field circuit of a loaded shunt motor is suddenly opened
(a) it would race to almost infinite speed
(b) it would draw abnormally high armature current
(c) circuit breaker or fuse will open the circuit before too much damage is done to the motor
(d) torque developed by the motor would be reduced to zero.
21. Which of the following d.c. motor would be suitable for drives requiring high starting torque but only fairly constant speed such as crushers ?
(a) shunt (b) series
(c) compound (d) permanent magnet
22. A d.c. shunt motor is found suitable to drive fans because they require
(a) small torque at start up
(b) large torque at high speeds
(c) practically constant voltage
(d) both (a) and (b)
23. Which of the following load would be best driven by a d.c. compound motor ?
(a) reciprocating pump
(b) centrifugal pump
(c) electric locomotive
(d) fan
24. As the load is increased, the speed of a d.c. shunt motor
(a) increases proportionately
(b) remains constant
(c) increases slightly
(d) reduces slightly
25. Between no-load and full-load, motor develops the *least* torque
(a) series
(b) shunt
(c) cumulative compound
(d) differential compound

26. The T_d/I_a graph of a d.c. series motor is a
 (a) parabola from no-load to overload
 (b) straight line throughout
 (c) parabola throughout
 (d) parabola upto full-load and a straight line at overloads.
27. As compared to shunt and compound motors, series motor has the highest torque because of its comparatively at the start.
 (a) lower armature resistance
 (b) stronger series field
 (c) fewer series turns
 (d) larger armature current
28. Unlike a shunt motor, it is difficult for a series motor to stall under heavy loading because
 (a) it develops high overload torque
 (b) its flux remains constant
 (c) it slows down considerably
 (d) its back e.m.f. is reduced to almost zero.
29. When load is removed, motor will run at the **highest** speed.
 (a) shunt
 (b) cumulative-compound
 (c) differential compound
 (d) series
30. A series motor is best suited for driving
 (a) lathes
 (b) cranes and hoists
 (c) shears and punches
 (d) machine tools
31. A 220 V shunt motor develops a torque of 54 N-m at armature current of 10 A. The torque produced when the armature current is 20 A, is
 (a) 54 N-m (b) 81 N-m
 (c) 108 N-m (d) None of the above
(Elect. Machines, A.M.I.E. Sec. B, 1993)
32. The d.c. series motor should never be switched on at no load because
 (a) the field current is zero
 (b) The machine does not pick up
 (c) The speed becomes dangerously high
 (d) It will take too long to accelerate.
(Grad. I.E.T.E. June 1988)
33. A shunt d.c. motor works on a.c. mains
 (a) unsatisfactorily (b) satisfactorily
 (c) not at all (d) none of the above
(Elect. Machines, A.M.I.E. Sec. B, 1993)
34. A 200 V, 10 A motor could be rewound for 100 V, 20 A by using as many turns per coil of wire, having the cross-sectional area.
 (a) twice, half
 (b) thrice, one third
 (c) half, twice
 (d) four times, one-fourth

ANSWERS

1. (d) 2. (c) 3. (b) 4. (a) 5. (a) 6. (a) 7. (b) 8. (d) 9. (a) 10. (a) 11. (a)
 12. (d) 13. (a) 14. (d) 15. (a) 16. (b) 17. (b) 18. (c) 19. (b) 20. (c) 21. (c) 22. (d)
 23. (a) 24. (d) 25. (a) 26. (d) 27. (b) 28. (a) 29. (d) 30. (b) 31. (c) 32. (c) 33. (a)
 34. (c).