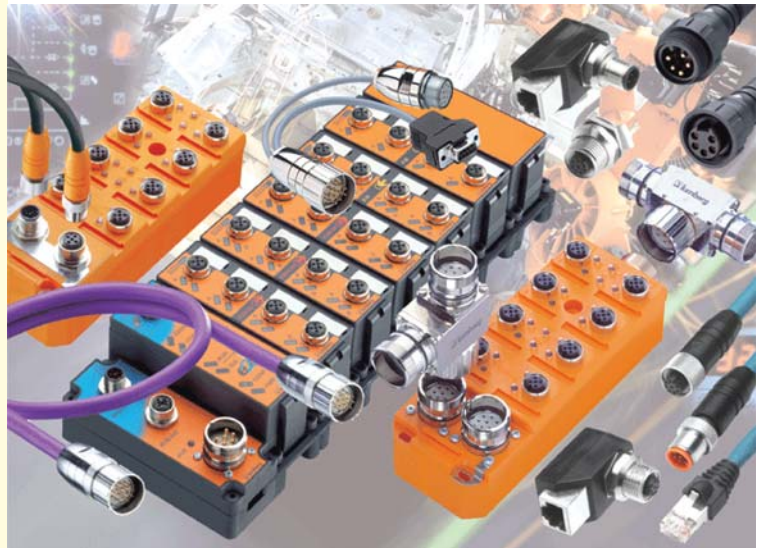

CHAPTER **15****Learning Objectives**

- Introduction
- Kirchhoff's Laws
- Mesh Analysis
- Nodal Analysis
- Superposition Theorem
- Thevenin's Theorem
- Reciprocity Theorem
- Norton's Theorem
- Maximum Power Transfer Theorem-General Case
- Maximum Power Transfer Theorem
- Millman's Theorem

**A.C.
NETWORK
ANAYLSIS**

↑ Engineers use AC network analysis in thousands of companies worldwide in the design, maintenance and operation of electrical power systems

15.1. Introduction

We have already discussed various d.c. network theorems in Chapter 2 of this book. The same laws are applicable to a.c. networks except that instead of resistances, we have impedances and instead of taking algebraic sum of voltages and currents we have to take the phasor sum.

15.2. Kirchhoff's Laws

The statements of Kirchhoff's laws are similar to those given in Art. 2.2 for d.c. networks except that instead of algebraic sum of currents and voltages, we take phasor or vector sums for a.c. networks.

1. Kirchhoff's Current Law. According to this law, in any electrical network, the phasor sum of the currents meeting at a junction is zero.

In other words, $\sum I = 0$...at a junction

Put in another way, it simply means that in any electrical circuit the phasor sum of the currents flowing towards a junction is equal to the phasor sum of the currents going away from that junction.

2. Kirchhoff's Voltage Law. According to this law, the phasor sum of the voltage drops across each of the conductors in any closed path (or mesh) in a network plus the phasor sum of the e.m.fs. connected in that path is zero.

In other words, $\sum IR + \sum e.m.f. = 0$...round a mesh

Example 15.1. Use Kirchhoff's laws to find the current flowing in each branch of the network shown in Fig. 15.1.

Solution. Let the current distribution be as shown in Fig. 15.1 (b). Starting from point A and applying KVL to closed loop ABEFA, we get

$$-10(x + y) - 20x + 100 = 0 \quad \text{or} \quad 3x + y = 10 \quad \dots(i)$$

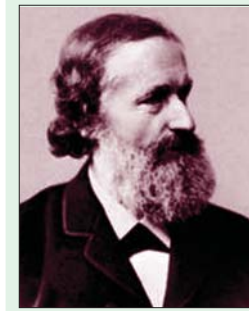

Gustav Kirchhoff
(1824-1887)

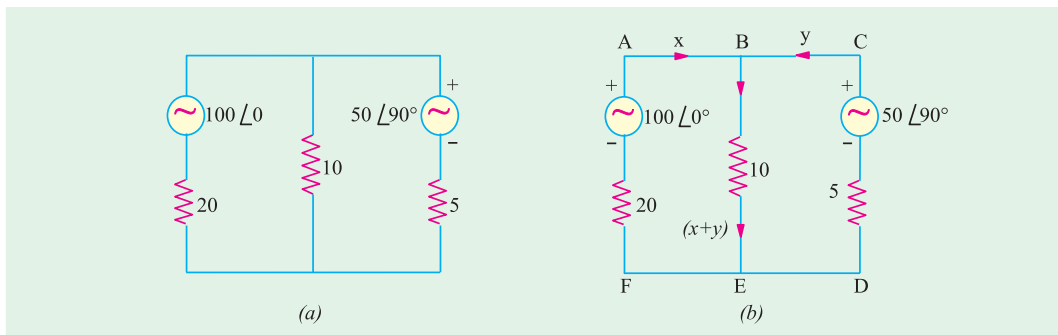
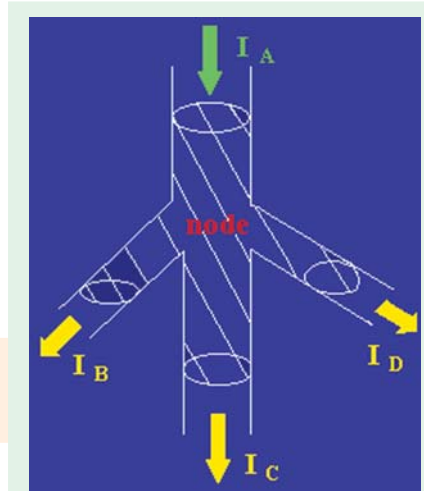

Fig. 15.1

Similarly, considering the closed loop BCDEB and starting from point B, we have

$$-50 \angle 90^\circ + 5y + 10(x + y) = 0 \quad \text{or} \quad 2x + 3y = j10 \quad \dots(ii)$$

Multiplying Eq. (i) by 3 and subtracting it from Eq. (ii), we get

$$7x = 30 - j10 \quad \text{or} \quad x = 4.3 - j1.4 = 4.52 \angle -18^\circ$$

Substituting this value of x in Eq. (i), we have

$$y = 10 - 3x = 5.95 \angle 119.15^\circ = -2.9 + j5.2$$

$$\therefore x + y = 4.3 - j1.4 - 2.9 + j5.2 = 1.4 + j3.8$$

Tutorial Problem No. 15.1

- Using Kirchhoff's Laws, calculate the current flowing through each branch of the circuit shown in Fig. 15.2 $[I = 0.84 \angle 47.15^\circ \text{ A}; I_1 = 0.7 \angle -88.87^\circ \text{ A}; I_2 = 1.44 \angle 67.12^\circ \text{ A}]$

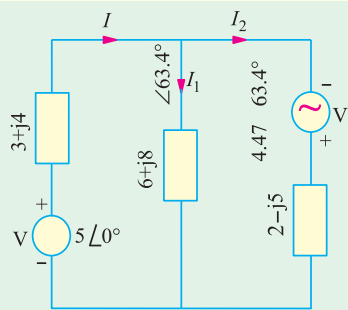

Fig. 15.2

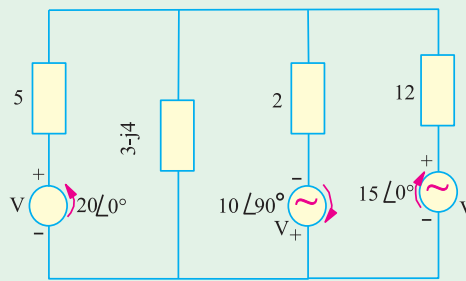

Fig. 15.3

- Use Kirchhoff's laws to find the current flowing in the capacitive branch of Fig. 15.3 $[5.87 \text{ A}]$

15.3. Mesh Analysis

It has already been discussed in Art. 2.3. Sign convention regarding the voltage drops across various impedances and the e.m.f.s is the same as explained in Art. 2.3. The circuits may be solved with the help of KVL or by use of determinants and Cramer's rule or with the help of impedance matrix $[Z_m]$.

Example 15.2. Find the power output of the voltage source in the circuit of Fig. 15.4. Prove that this power equals the power in the circuit resistors.

Solution. Starting from point A in the clockwise direction and applying KVL to the mesh ABEFA, we get.

$$-8 I_1 - j6 (I_1 - I_2) + 100 \angle 0^\circ = 0$$

$$\text{or } I_1 (8 - j6) + I_2 (j6) = 100 \angle 0^\circ \quad \dots(i)$$

Similarly, starting from point B and applying KVL to mesh BCDEB, we get

$$-I_2(3 + j4) - (j6) (I_2 - I_1) = 0$$

$$\text{or } I_1 (j6) + I_2 (3 - j2) = 0 \quad \dots(ii)$$

The matrix form of the above equation is

$$\begin{bmatrix} (8 - j6) & j6 \\ j6 & (3 - j2) \end{bmatrix} = \begin{bmatrix} I_1 \\ I_2 \end{bmatrix} = \begin{bmatrix} 100 \angle 0^\circ \\ -0 \end{bmatrix}$$

$$\Delta = \begin{vmatrix} (8 - j6) & j6 \\ j6 & (3 - j2) \end{vmatrix} = (8 - j6)(3 - j2) - (j6)^2 = 62.5 \angle -39.8^\circ$$

$$\Delta_1 = \begin{vmatrix} 100 \angle 0^\circ & j6 \\ 0 & (3 - j2) \end{vmatrix} = (300 - j200) = 360 \angle -26.6^\circ$$

$$\Delta_2 = \begin{vmatrix} (8 - j6) & 100 \angle 0^\circ \\ j6 & 0 \end{vmatrix} = 600 \angle 90^\circ$$

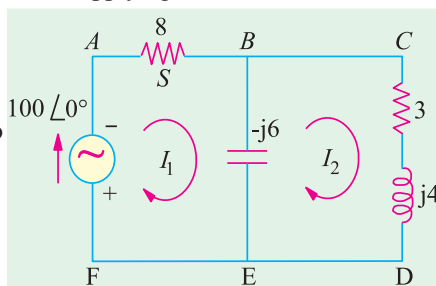

Fig. 15.4

$$I_1 = \frac{\Delta_1}{\Delta} = \frac{360 \angle -26.6^\circ}{62.5 \angle -39.8^\circ} = 5.76 \angle 13.2^\circ; I_2 = \frac{\Delta_2}{\Delta} = \frac{600 \angle 90^\circ}{62.5 \angle -39.8^\circ} = 9.6 \angle 129.8^\circ$$

Example 15.3. Using Maxwell's loop current method, find the value of current in each branch of the network shown in Fig. 15.5 (a).

Solution. Let the currents in the two loops be I_1 and I_2 flowing in the clockwise direction as shown in Fig. 15.5 (b). Applying KVL to the two loops, we get

Loop No. 1

$$25 - I_1(40 + j50) - (-j100)(I_1 - I_2) = 0$$

$$\therefore 25 - I_1(40 - j50) - j100 I_2 = 0 \quad \dots(i)$$

Loop No. 2

$$-60 I_2 - (-j100)(I_2 - I_1) = 0$$

$$\therefore j100 I_1 - I_2(60 - j100) = 0$$

$$\therefore I_2 = \frac{-j100 I_1}{(60 - j100)} = \frac{100 \angle -90^\circ I_1}{116.62 \angle -59^\circ} = 0.8575 \angle 31^\circ I_1 \quad \dots(ii)$$

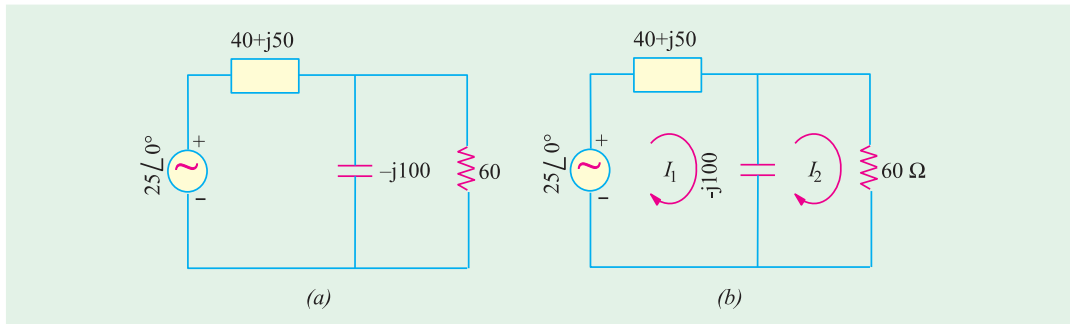

Fig. 15.5

Substituting this value of I_2 in (i) above, we get $25 - I_1(40 - j50) - j100 \times 0.8575 \angle 31^\circ I_1 = 0$

$$\text{or } 25 - 40 I_1 + j50 I_1 - 85.75 \angle 59^\circ I_1 = 0 \quad (j100 = 100 \angle 90^\circ)$$

$$\text{or } 25 - I_1(84.16 + j23.5) = 0.$$

$$\therefore I_1 = \frac{25}{(84.16 + j23.5)} = \frac{25}{87.38 \angle 15.6^\circ} = 0.286 \angle -15.6^\circ \text{ A}$$

$$\text{Also, } I_2 = 0.8575 \angle 31^\circ I_1 \times 0.286 \angle -15.6^\circ = 0.2452 \angle 46.6^\circ \text{ A}$$

Current through the capacitor = $(I_1 - I_2) = 0.286 \angle -15.6^\circ - 0.2452 \angle 46.6^\circ = 0.107 + j0.1013 = 0.1473 \angle 43.43^\circ \text{ A}.$

Example 15.4. Write the three mesh current equations for network shown in Fig. 15.6.

Solution. While moving along I_1 , if we apply KVL, we get

$$-(j10) I_1 - 10(I_1 - I_2) - 5(I_1 - I_3) = 0$$

$$\text{or } I_1(15 - j10) - 10 I_2 - 5 I_3 = 0 \quad \dots(i)$$

In the second loop, current through the a.c. source is flowing upwards indicating that its upper end is positive and lower is negative. As we move along I_2 , we go from the positive terminal of the voltage source to its negative terminal. Hence, we

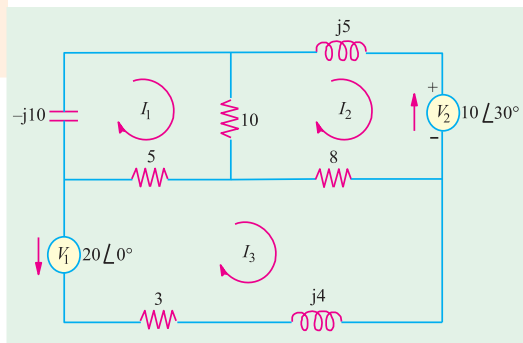

Fig. 15.6

experience a decrease in voltage which as per Art. would be taken as negative.

$$-j5 I_2 - 10 \angle 30^\circ - 8(I_2 - I_3) - 10(I_2 - I_1) = 0$$

$$\text{or } 10 I_1 - I_2 (18 + j5) + 8 I_3 = 10 \angle 30^\circ \quad \dots(ii)$$

Similarly, from third loop, we get

$$-20 \angle 0^\circ - 5(I_3 - I_1) - 8(I_3 - I_2) - I_3 (3 + j4) = 0$$

$$\text{or } 5 I_1 + 8 I_2 - I_3 (16 + j4) = 20 \angle 0^\circ \quad \dots(iii)$$

The values of the three currents may be calculated with the help of Cramer's rule. However, the same values may be found with the help of mesh impedance $[Z_m]$ whose different items are as under :

$$Z_{11} = -j10 + 10 + 5 = (15 - j10); Z_{22} = (18 + j5)$$

$$Z_{33} = (16 + j5); Z_{12} = Z_{21} = -10; Z_{23} = Z_{32} = -8$$

$$Z_{13} = Z_{31} = -5; E_1 = 0; E_2 = -10 \angle 30^\circ; E_3 = -20 \angle 0^\circ$$

Hence, the mesh equations for the three currents in the matrix form are as given below :

$$\begin{bmatrix} (15 - j10) & -10 & -5 \\ -10 & (18 + j5) & -8 \\ -5 & -8 & (16 + j5) \end{bmatrix} \begin{bmatrix} I_1 \\ I_2 \\ I_3 \end{bmatrix} = \begin{bmatrix} 0 \\ -10 \angle 30^\circ \\ -20 \angle 0^\circ \end{bmatrix}$$

Example 15.5. For the circuit shown in Fig. 15.7 determine the branch voltage and currents and power delivered by the source using mesh analysis.

(Elect. Network Analysis Nagpur Univ. 1993)

Solution. Let the mesh currents be as shown in Fig. 15.7. The different items of the mesh resistance matrix $[E_m]$ are :

$$Z_{11} = (2 + j1 + j2 - j1) = (2 + j2)$$

$$Z_{22} = (-j2 + 1 - j1 + j2) = (1 - j1)$$

$$Z_{12} = Z_{21} = -(j2 - j1) = -j1$$

Hence, the mesh equations in the matrix form are

$$\begin{bmatrix} (2 + j2) & -j1 \\ -j1 & (1 - j1) \end{bmatrix} \begin{bmatrix} I_1 \\ I_2 \end{bmatrix} = \begin{bmatrix} 10 \angle 0^\circ \\ -5 \angle 30^\circ \end{bmatrix}$$

$$\therefore \Delta = (2 + j2)(1 - j1) + 1 = 5$$

$$\Delta_1 = \begin{bmatrix} 10 & -j1 \\ -(4.43 + j2.5) & (1 - j1) \end{bmatrix} = 10(1 - j1) - j1(4.43 + j2.5) = 12.5 - j14.43 = 19.1 \angle -49.1^\circ$$

$$\begin{aligned} \Delta_2 &= \begin{bmatrix} (2 + j2) & 10 \\ -j1 & -(4.43 + j2.5) \end{bmatrix} = (2 + j2)(4.43 + j2.5) + j10 = -3.86 - j3.86 \\ &= 5.46 \angle -135^\circ \text{ or } \angle 225^\circ \end{aligned}$$

$$I_1 = \Delta_1 / \Delta = 19.1 \angle -49.1^\circ / 5 = 3.82 \angle -49.1^\circ = 2.5 - j2.89$$

$$I_2 = \Delta_2 / \Delta = 5.46 \angle -135^\circ / 5 = 1.1 \angle -135^\circ = -0.78 - j0.78$$

Current through branch $BC = I_1 - I_2 = 2.5 - j2.89 + 0.78 + j0.78 = 3.28 - j2.11 = 3.49 \angle -32.75^\circ$

Drop over branch $AB = (2 + j1)(2.5 - j2.89) = 7.89 - j3.28$

Drop over branch $BD = (1 - j2)(-0.78 - j0.78) = 2.34 + j0.78$

Drop over branch $BC = j1(I_1 - I_2) = j1(3.28 - j2.11) = 2.11 + j3.28$

Power delivered by the sources would be found by using conjugate method. Using current conjugate, we get

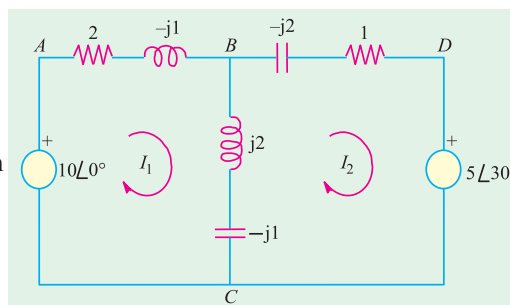

Fig. 15.7

$$VA_1 = 10(2.5 + j2.89) = 25 + j28.9 ; \quad \therefore W_1 = 25 \text{ W}$$

$VA_2 = V_2 \times I_2$ — because $-I_2$ is the current coming out of the second voltage source. Again, using current conjugate, we have

$$VA_2 = (4.43 + j2.5)(0.78 - j0.78) \text{ or } W_2 = 4.43 \times 0.78 + 2.5 \times 0.78 = 5.4 \text{ W}$$

$$\therefore \text{total power supplied by the two sources} = 25 + 5.4 = 30.4 \text{ W}$$

Incidentally, the above fact can be verified by adding up the powers dissipated in the three branches of the circuit. It may be noted that there is no power dissipation in the branch BC .

$$\text{Power dissipated in branch } AB = 3.82^2 \times 2 = 29.2 \text{ W}$$

$$\text{Power dissipated in branch } BD = 1.1^2 \times 1 = 1.21 \text{ W}$$

$$\text{Total power dissipated} = 29.2 + 1.21 = 30.41 \text{ W.}$$

Tutorial Problems No. 15.2

1. Using mesh analysis, find current in the capacitor of Fig. 15.8.

[13.1 $\angle 70.12^\circ$ A]

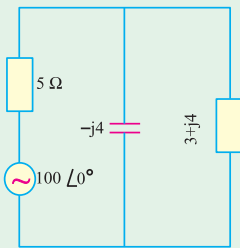

Fig. 15.8

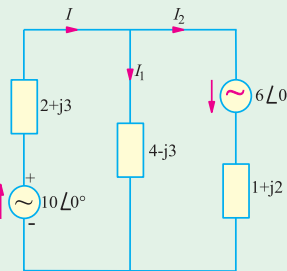

Fig. 15.9

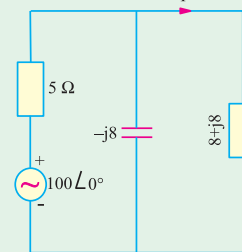

Fig. 15.10

2. Using mesh analysis or Kirchoff's laws, determine the values of I , I_1 and I_2 (in Fig. 15.9)

[$I = 2.7 \angle -58.8^\circ$ A ; $I_1 = 0.1 \angle 97^\circ$ A ; $I_2 = 2.8 \angle -59.6^\circ$ A]

3. Using mesh current analysis, find the value of current I and active power output of the voltage source in Fig. 15.10.

[7 $\angle -50^\circ$ A ; 645 W]

4. Find the mesh currents I_1 , I_2 and I_3 for the circuit shown in Fig. 15.11. All resistances and reactances are in ohms.

[$I_1 = (1.168 + j1.281)$; $I_2 = (0.527 - j0.135)$; $I_3 = (0.718 + j0.412)$]

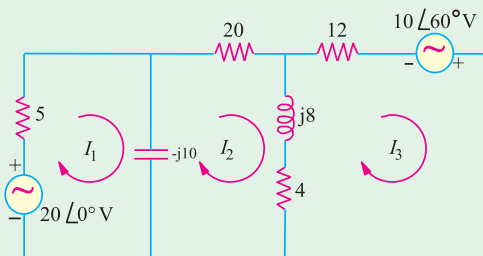

Fig.15.11

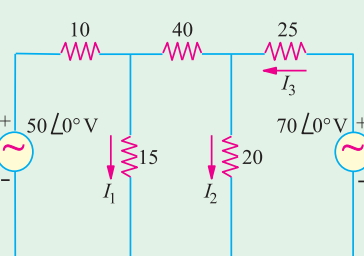

Fig. 15.12

5. Find the values of branch currents I_1 , I_2 and I_3 in the circuit shown in Fig. 15.12 by using mesh analysis. All resistances are in ohms.

[$I_1 = 2.008 \angle 0^\circ$; $I_2 = 1.545 \angle 0^\circ$; $I_3 = 1.564 \angle 0^\circ$]

6. Using mesh-current analysis, determine the current I_1 , I_2 and I_3 flowing in the branches of the networks shown in Fig. 15.13.

[$I_1 = 8.7 \angle -1.37^\circ$ A ; $I_2 = 3 \angle -48.7^\circ$ A ; $I_3 = 7 \angle 17.25^\circ$ A]

7. Apply mesh-current analysis to determine the values of current I_1 to I_5 in different branches of the circuit shown in Fig. 15.14.

[$I_1 = 2.4 \angle 52.5^\circ$ A ; $I_2 = 1.0 \angle 46.18^\circ$ A ; $I_3 = 1.4 \angle 57.17^\circ$ A ; $I_4 = 0.86 \angle 166.3^\circ$ A ; $I_5 = 1.0 \angle 83.7^\circ$ A]

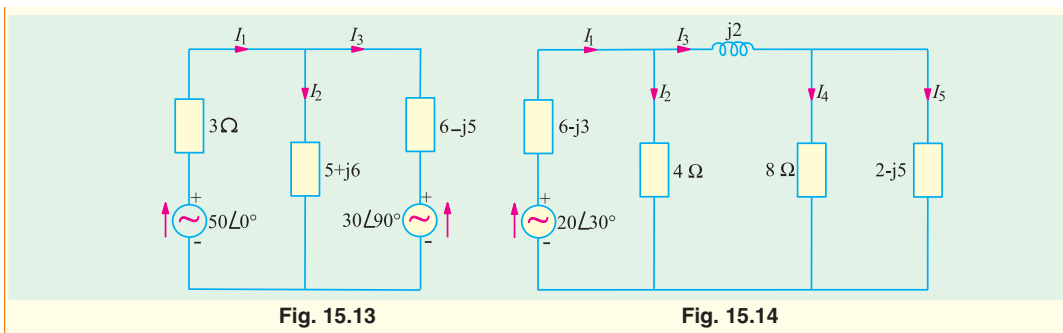

15.4. Nodal Analysis

This method has already been discussed in details Chapter 2. This technique is the same although we have to deal with circuit impedances rather than resistances and take phasor sum of voltages and currents rather than algebraic sum.

Example 15.6. Use Nodal analysis to calculate the current flowing in each branch of the network shown in Fig. 15.15.

Solution. As seen, there are only two principal nodes out of which node No. 2 has been taken as the reference node. The nodal equations are :

$$V_1 \left(\frac{1}{20} + \frac{1}{10} + \frac{1}{5} \right) - \frac{100\angle 0^\circ}{20} - \frac{50\angle 90^\circ}{5} = 0$$

$$\therefore 0.35 V_1 = 5 + j10; V_1 = \frac{5 + j10}{0.35}$$

$$= 14.3 + j28.6 = 32\angle 63.4^\circ$$

$$\therefore I_1 = \frac{100\angle 0^\circ - V_1}{20} = \frac{100 - 14.3 - j28.6}{20}$$

$$= 4.3 - j1.4 = 4.5 \angle -18^\circ \text{ flowing towards node No. 1}$$

(or $4.5 \angle -18^\circ + 180^\circ = 4.5 \angle 162^\circ$ flowing away from node No. 1)

$$I_3 = \frac{V_1}{10} = \frac{32\angle 63.4^\circ}{10} = 3.2\angle 63.4^\circ = 1.4 + j2.9 \text{ flowing from node No. 1 to node No. 2}$$

$$I_2 = \frac{50\angle 90^\circ - V_1}{5} = \frac{j50 - 14.3 - j28.6}{5} = \frac{-14.3 + j21.4}{5} = -2.86 + j4.3 = 5.16\angle 123.6^\circ$$

flowing towards node No. 1
 $\angle 123.6^\circ - 180^\circ = 5.16 \angle 56.4^\circ$ flowing away from node No. 1).

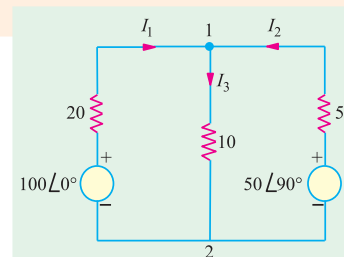

Fig. 15.15

Example 15.7. Find the current I in the $j10 \Omega$ branch of the given circuit shown in Fig. 15.16 using the Nodal Method. (Principles of Elect. Engg. Delhi Univ.)

Solution. There are two principal nodes out of which node No. 2 has been taken as the reference node. As per Art.

$$V_1 \left(\frac{1}{6+j8} + \frac{1}{6-j8} + \frac{1}{j10} \right) - \frac{100\angle 0^\circ}{6+j8} - \frac{100\angle -60^\circ}{6-j8} = 0$$

$$V_1(0.06 - j0.08 + 0.06 + j0.08 - j0.1) = 6 - j8 + 9.93 - j11.2 = 18.4 \angle 30^\circ$$

$$\therefore V_1(0.12 - j0.1) = 18.4 \angle 30^\circ \text{ or}$$

$$V_1 \times 0.156 \angle -85.6^\circ = 18.4 \angle 30^\circ$$

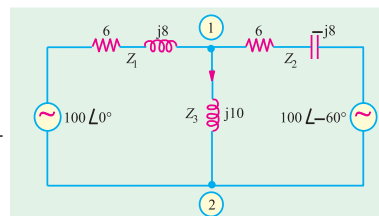

Fig. 15.16

$$\begin{aligned} \therefore V_1 &= 18.4 \angle 30^\circ / 0.156 \angle 85.6^\circ = 118 \angle 55.6^\circ \text{V} \\ \therefore V &= V_1 / j10 = 118 \angle 55.6^\circ / j10 = 11.8 \angle 34.4^\circ \text{A} \end{aligned}$$

Example 15.8. Find the voltage V_{AB} in the circuit of Fig. 15.17 (a). What would be the value of V_1 if the polarity of the second voltage source is reversed as shown in Fig. 15.17 (b).

Solution. In the given circuit, there are no principle nodes. However, if we take point B as the reference node and point A as node 1, then using nodal method, we get

$$V_1 \left(\frac{1}{10} + \frac{1}{8+j4} \right) - \frac{10 \angle 0^\circ}{10} - \frac{10 \angle 30^\circ}{8+j4} = 0$$

$$V_1 \times 0.2 \angle 14.1^\circ = 1 + 1.116 + j0.066 = 4.48 \angle 1.78^\circ$$

$$\therefore V_1 = 4.48 \angle 1.78^\circ / 0.2 \angle 14.1^\circ = 22.4 \angle 15.88^\circ$$

When source polarity is Reversed

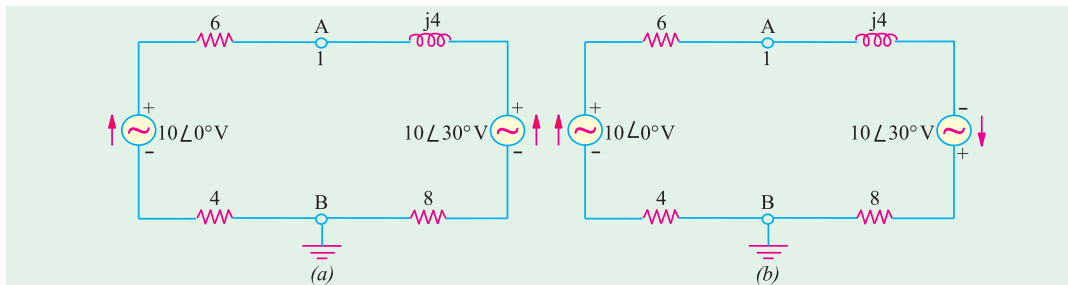

Fig. 15.17

$$V_1 \left(\frac{1}{10} + \frac{1}{8+j4} \right) - \frac{10 \angle 0^\circ}{10} + \frac{10 \angle 30^\circ}{8+j4} = 0 \text{ or } V_1 = 0.09 \angle 223.7^\circ$$

Example 15.9. Write the nodal equations for the network shown in Fig. 15.18.

Solution. Keeping in mind the guidance given in Art. 2.10, it would be obvious that since current of the second voltage source is flowing away from node 1, it would be taken as negative. Hence, the term containing this source will become positive because it has been reversed twice. As seen, node 3 has been taken as the reference node. Considering node 1, we have

$$V_1 \left(\frac{1}{10} + \frac{1}{4+j4} + \frac{1}{j5} \right) - \frac{V_2}{4+j4} - \frac{10 \angle 0^\circ}{10} + \frac{10 \angle 30^\circ}{j5} = 0$$

Similarly, considering node 2, we have

$$V_2 \left(\frac{1}{4+j4} + \frac{1}{5} + \frac{1}{6-j8} \right) - \frac{V_1}{4+j4} - \frac{5 \angle 0^\circ}{5} = 0$$

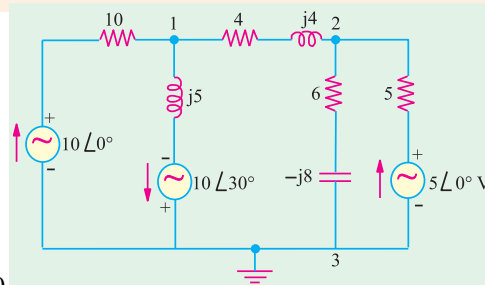

Fig. 15.18

Example 15.10. In the network of Fig. 15.19 determine the current flowing through the branch of 4Ω resistance using nodal analysis. (Network Analysis Nagpur Univ. 1993)

Solution. We will find voltages V_A and V_B by using Nodal analysis and then find the current through 4Ω resistor by dividing their difference by 4.

$$V_2 \left(\frac{1}{5} + \frac{1}{4} + \frac{1}{j2} \right) - \frac{V_B}{4} - \frac{50 \angle 30^\circ}{5} = 0 \quad \dots \text{for node A}$$

$$\therefore V_A(9 - j10) - 5V_B = 200 \angle 30^\circ \quad \dots (i)$$

Similarly, from node B, we have

$$V_B \left(\frac{1}{4} + \frac{1}{2} + \frac{1}{-j2} \right) - \frac{V_A}{4} - \frac{50 \angle 90^\circ}{2} = 0 \quad \therefore V_B(3 + j2) - V_A = 100 \angle 90^\circ = j100 \quad \dots (ii)$$

V_A can be eliminated by multiplying Eq. (ii) by (9-j10) and adding the result.

$$\therefore V_B(42 - j12) = 1173 + j1000 \quad \text{or} \quad V_B = \frac{1541.4 \angle 40.40^\circ}{43.68 \angle -15.9^\circ} = 35.29 \angle 56.3^\circ = 19.58 + j29.36$$

Substituting this value of V_B in Eq. (ii), we get

$$V_A = V_B(3 + j2) - j100 = (19.58 + j29.36)(3 + j2) - j100 = j27.26$$

$$\therefore V_A - V_B = j27.26 - 19.58 - j29.36 = -19.58 - j2.1 = 19.69 \angle 186.12^\circ$$

$$\therefore I_2 = (V_A - V_B)/4 = 19.69 \angle 186.12^\circ / 4 = 4.92 \angle 186.12^\circ$$

For academic interest only, we will solve the above question with the help of following two methods :

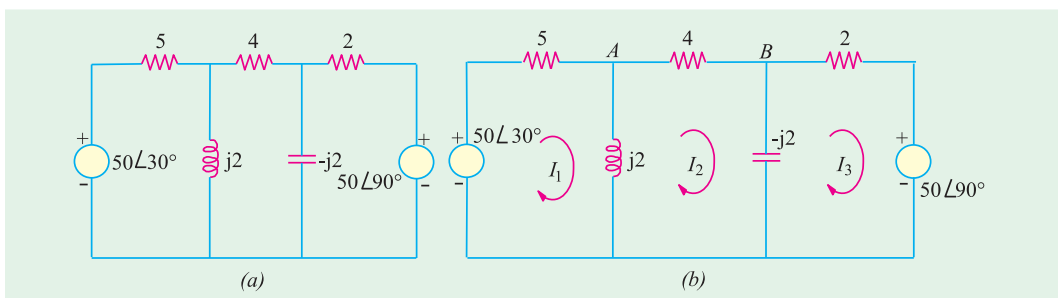

Fig. 15.19

Solution by Using Mesh Resistance Matrix

Let the mesh currents I_1 , I_2 and I_3 be as shown in Fig. 15.19 (b). The different items of the mesh resistance matrix $[R_m]$ are as under :

$$R_{11} = (5 + j2) ; R_{22} = 4 ; R_{33} = (2 - j2) ; R_{12} = R_{21} = -j2 ;$$

$$R_{23} = R_{32} = j2 ; R_{31} = R_{13} = 0$$

The mesh equations in the matrix form are :

$$\begin{bmatrix} (5 + j2) & -j2 & 0 \\ -j2 & 4 & j2 \\ 0 & j2 & (2 - j2) \end{bmatrix} \begin{bmatrix} I_1 \\ I_2 \\ I_3 \end{bmatrix} = \begin{bmatrix} 50 \angle 30^\circ \\ 0 \\ -j50 \end{bmatrix}$$

$$\Delta = (5 + j2) [4(2 - j2) - (j2 \times j2)] - (j2) [(j2)(2 - j2)] = 84 - j24 = 87.4 \angle -15.9^\circ$$

$$\Delta_2 = \begin{bmatrix} (5 + j2) & (43.3 + j25) & -0 \\ -j2 & 0 & j2 \\ 0 & -j50 & (2 - j2) \end{bmatrix} = (5 + j2) [j2(j50)] +$$

$$j2 [43.3 + j25)(2 - j2)] = -427 + j73 = 433 \angle 170.3^\circ$$

$$\therefore I_2 \Delta_2 / \Delta = 433 \angle 170.3^\circ / 87.4 \angle -15.9^\circ = 4.95 \angle 186.2^\circ$$

Solution by using Thevenin's Theorem

When the 4Ω resistor is disconnected, the given figure becomes as shown in Fig. 15.20 (a). The voltage V_A is given by the drop across $j2$ reactance. Using the voltage-divider rule, we have

$$V_A = 50 \angle 30^\circ \times \frac{j2}{5 + j2} = 18.57 \angle 98.2^\circ = -2.65 + j18.38$$

$$\text{Similarly, } V_B = 50 \angle 90^\circ \frac{-j2}{2 - j2} = 35.36 \angle 45^\circ = 25 + j25$$

$$\therefore V_{th} = V_A - V_B = -2.65 + 18.38 - 25 - j25 = 28.43 \angle 193.5^\circ$$

$$R_{th} = 5 \parallel j2 + 2 \parallel (-j2) = \frac{j10}{5 + j2} + \frac{-j4}{2 - j2} = 1.689 + j0.72$$

The Thevenin's equivalent circuit consists of a voltage source of $28.43 \angle 193.5^\circ$ V and an impedance of $(1.689 + j0.72) \Omega$ as shown in Fig. 15.20 (c). Total resistance is $4 + (1.689 + j0.72) = 5.689 + j0.72 = 5.73 \angle 7.2^\circ$. Hence, current through the 4Ω resistor is $28.43 \angle 193.5^\circ / 5.73 \angle 7.2^\circ = 4.96 \angle 186.3^\circ$.

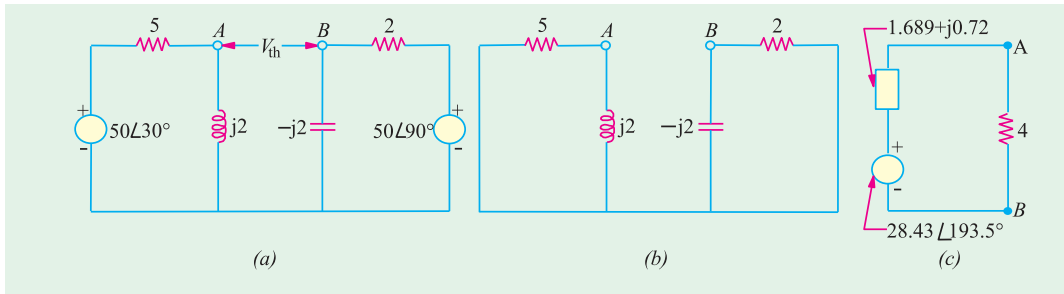

Fig. 15.20

Note. The slight variations in the answers are due to the approximations made during calculations.

Example 15.11. Using any suitable method, calculate the current through 4Ω resistance of the network shown in Fig. 15.21. (Network Analysis AMIE Sec. B Summer 1990)

Solution. We will solve this question with the help of (i) Kirchhoff's laws (ii) Mesh analysis and (iii) Nodal analysis.

(i) Solution by using Kirchhoff's Laws

Let the current distribution be as shown in Fig. 15.21 (b). Using the same sign convention as given in Art. we have

$$\begin{aligned} \text{First Loop} & -10(I_1 + I_2 + I_3) - (j5) I_1 + 100 = 0 \\ \text{or} & I_1 (10 - j5) + 10 I_3 + 10 I_2 = 100 \quad \dots(i) \end{aligned}$$

$$\begin{aligned} \text{Second Loop} & -5(I_2 + I_3) - 4I_2 + (j5) I_1 = 0 \\ \text{or} & j5I_1 + 9 I_2 + 5I_3 = 0 \quad \dots(ii) \end{aligned}$$

$$\begin{aligned} \text{Third Loop} & -I_3 (8 + j6) + 4I_2 = 0 \\ \text{or} & 0I_1 + 4I_2 - I_3 (8 + j6) = 0 \quad \dots(iii) \end{aligned}$$

The matrix form of the above three equations is

$$\begin{bmatrix} (10-j5) & -10 & 10 \\ j5 & 9 & 5 \\ 0 & 4 & -(8+j6) \end{bmatrix} \begin{bmatrix} I_1 \\ I_2 \\ I_3 \end{bmatrix} = \begin{bmatrix} 100 \\ 0 \\ 0 \end{bmatrix}$$

$$\begin{aligned} \Delta &= (10-j5) [-9(8+j6)-20] -j5 [-10(8+j6)-40] \\ &= -1490 + j520 = 1578 \angle 160.8^\circ \end{aligned}$$

Since we are interested in finding I_2 only, we will calculate the value of Δ_2 .

$$\Delta_2 = \begin{bmatrix} (10-j5) & 100 & 10 \\ j5 & 0 & 5 \\ 0 & 0 & -(8+j6) \end{bmatrix}$$

$$= -j5(-800-j600) = -3000 + j4000 = 5000 \angle 126.9^\circ$$

$$I_2 = \frac{\Delta_2}{\Delta} = \frac{5000 \angle 126.9^\circ}{1578 \angle 160.8^\circ} = 3.17 \angle -33.9^\circ \text{ A}$$

(ii) Solution by using Mesh Impedance Matrix

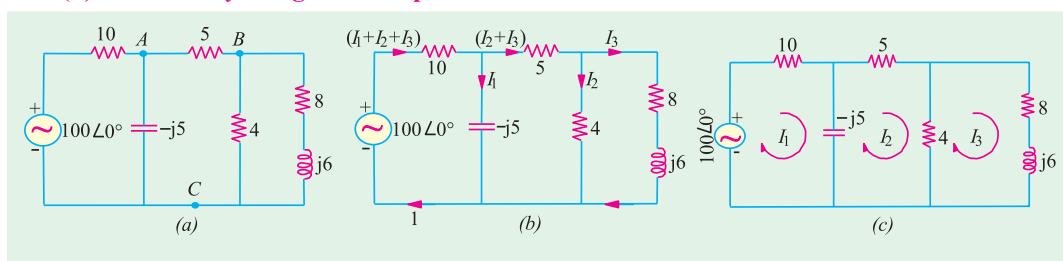

Fig. 15.21

Let the mesh currents I_1 , I_2 and I_3 be as shown in Fig. 15.21 (c). From the inspection of Fig. 15.21 (c), the different items of the mesh impedance matrix $[Z_m]$ are as under :

$$Z_{11} = (10-j5); Z_{22} = (9-j5); Z_{33} = (12+j6)$$

$$Z_{21} = Z_{12} = -(-j5) = j5; Z_{23} = Z_{32} = -4; Z_{31} = Z_{13} = 0$$

Hence, the mesh equations in the matrix form are :

$$\begin{bmatrix} (10-j5) & j5 & 0 \\ j5 & (9-j5) & -4 \\ 0 & -4 & (12+j6) \end{bmatrix} \begin{bmatrix} I_1 \\ I_2 \\ I_3 \end{bmatrix} = \begin{bmatrix} 100 \\ 0 \\ 0 \end{bmatrix}$$

$$\begin{aligned} \therefore \Delta &= (10-j5) [(9-j5)(12+j6)-16] -j5(j60-30) \\ &= 1490 - j520 = 1578 \angle 19.2^\circ \end{aligned}$$

It should be noted that the current passing through 4Ω resistance is the vector difference $(I_2 - I_3)$. Hence, we will find I_2 and I_3 only.

$$\Delta_2 = \begin{bmatrix} (10-j5) & 100 & 0 \\ j5 & 0 & -4 \\ 0 & 0 & (12+j6) \end{bmatrix} = j5(1200+j600) = 3000 - j6000 = 6708 \angle -63.4^\circ$$

$$\Delta_3 = \begin{bmatrix} (10-j5) & j5 & 100 \\ j5 & (9-j5) & 0 \\ 0 & -4 & 0 \end{bmatrix} = -j5(400) = -j2000 = 2000 \angle -90^\circ$$

$$\therefore I_2 = \frac{\Delta_2}{\Delta} = \frac{6708 \angle -63.4^\circ}{1578 \angle -19.2^\circ} = 4.25 \angle -44.2^\circ = 3.05 - j2.96$$

$$I_3 = \frac{\Delta_3}{\Delta} = \frac{2000 \angle -90^\circ}{1578 \angle -19.2^\circ} = 1.27 \angle -70.8^\circ = 0.42 - j1.2$$

$$\text{Current } (I_2 - I_3) = 2.63 - j1.76 = 3.17 \angle 33.9^\circ$$

(iii) Solution by Nodal Analysis

The current passing through 4Ω resistance can be found by finding the voltage V_B of node B with the help of Nodal analysis. For this purpose point C in Fig. 15.21 (a) has been taken as the reference node. Using the Nodal technique as explained in Art. we have

$$V_A \left(\frac{1}{10} + \frac{1}{5} + \frac{1}{-j5} \right) - \frac{V_B}{5} - \frac{100 \angle 0^\circ}{10} = 0 \quad \dots \text{for node A}$$

$$V_A (3 + j2) - 2V_B = 100 \quad \dots (i)$$

Similarly, for node B , we have

$$V_B \left(\frac{1}{5} + \frac{1}{4} + \frac{1}{(8 + j6)} \right) - \frac{V_A}{5} = 0 \quad \text{or} \quad V_B (53 - j6) - 20V_A = 0 \quad \dots (ii)$$

Estimating V_A from Eq. (i) and (ii), we have

$$V_B (131 + j88) = 2000 \quad \text{or} \quad V_B = 12.67 \angle 33.9^\circ$$

Current through 4Ω resistor $12.67 \angle 33.9^\circ / 4 = 3.17 \angle 33.9^\circ$

Tutorial Problems No. 15.3

- Apply nodal analysis to the network of Fig. 15.22 to determine the voltage at node A and the active power delivered by the voltage source. **[$8 \angle 3.7^\circ$ V; 9.85 W]**
- Using nodal analysis, determine the value of voltages at models 1 and 2 in Fig. 15.23. **[$V_1 = 88.1 \angle 33.88^\circ$ A; $V_2 = 58.7 \angle 72.34^\circ$ A]**

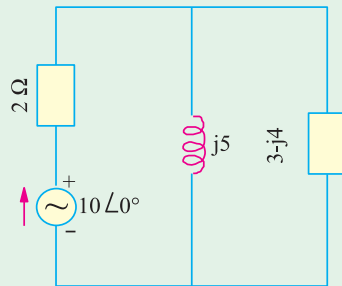

Fig. 15.22

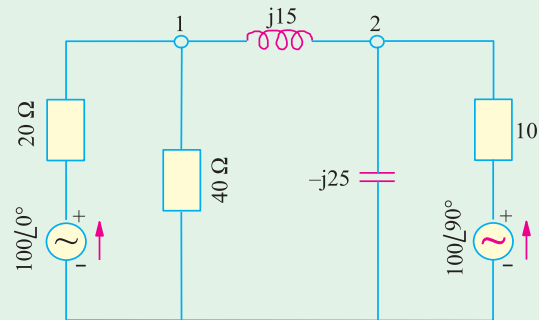

Fig. 15.23

- Using Nodal analysis, find the nodal voltages V_1 and V_2 in the circuit shown in Fig. 15.24. All resistances are given in terms of siemens **[$V_1 = 1.64$ V; $V_2 = 0.38$ V]**

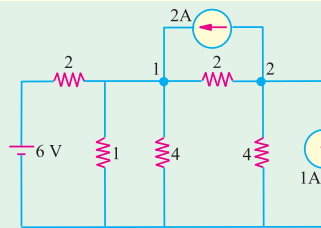

Fig. 15.24

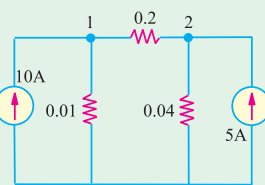

Fig. 15.25

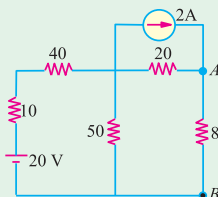

Fig. 15.26

4. Find the values of nodal voltages V_1 and V_2 in the circuit of Fig. 15.25. Hence, find the current going from node 1 to node 2. All resistances are given in siemens. [$V_1 = 327 \text{ V}$; $V_2 = 293.35 \text{ V}$; 6.73 A]
5. Using Nodal analysis, find the voltage across points A and B in the circuit of Fig. 15.26: Check your answer by using mesh analysis. [32 V]

15.5. Superposition Theorem

As applicable to a.c. networks, it states as follows :

In any network made up of linear impedances and containing more than one source of e.m.f., the current flowing in any branch is the phasor sum of the currents that would flow in that branch if each source were considered separately, all other e.m.f. sources being replaced for the time being, by their respective internal impedances (if any).

Note. It may be noted that independent sources can be ‘killed’ *i.e.* removed leaving behind their internal impedances (if any) but dependent sources should not be killed.

Example 15.12. Use Superposition theorem to find the voltage V in the network shown in Fig. 15.27.

Solution. When the voltage source is killed, the circuit becomes as shown in the Fig. 15.27 (b) Using current-divider rule,

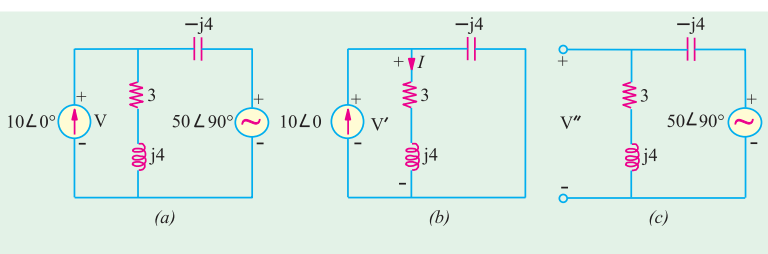

Fig. 15.27

$$I = 10\angle 0^\circ \times \frac{-j4}{(3+j4)-j4}, \text{ Now, } V' = I(3+j4)$$

$$\therefore V = 10 \frac{-j4(3+j4)}{3} = 53.3 - j40$$

Now, when current source is killed, the circuit becomes as shown in Fig. 15.27 (c). Using the voltage-divider rule, we have

$$V'' = 50\angle 90^\circ \times \frac{(3+j4)}{(3+j4)-j4} = -66.7 + j50$$

$$\therefore \text{ drop } V = V' + V'' = 53.3 - j40 - 66.7 + j50 = -13.4 + j10 = 16.7 \angle 143.3^\circ \text{ V}$$

Tutorial Problems No. 15.4

1. Using Superposition theorem to find the magnitude of the current flowing in the branch AB of the circuit shown in Fig. 15.28.

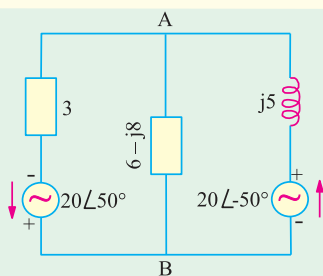

Fig. 15.28

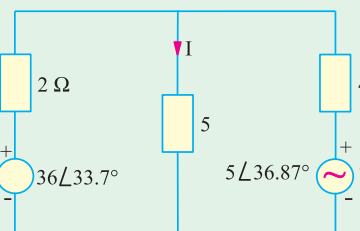

Fig. 15.29

2. Apply Superposition theorem to determine the circuit I in the circuit of Fig. 15.29. [$0.53 \angle 5.7^\circ \text{ A}$]

15.6. Thevenin's Theorem

As applicable to a.c. networks, this theorem may be stated as follows :

The current through a load impedance Z_L connected across any two terminals A and B of a linear network is given by $V_{th}/(Z_{th} + Z_L)$ when V_{th} is the open-circuit voltage across A and B and Z_{th} is the internal impedance of the network as viewed from the open-circuited terminals A and B with all voltage sources replaced by their internal impedances (if any) and current sources by infinite impedance.



Leon-Charles Thevenin

Example 15.13. In the network shown in Fig. 15.30.

$Z_1 = (8 + j8) \Omega$; $Z_2 = (8 - j8) \Omega$; $Z_3 = (2 + j20)$; $V = 10 \angle 0^\circ$ and $Z_L = j10 \Omega$

Find the current through the load Z_L using Thevenin's theorem.

Solution. When the load impedance Z_L is removed, the circuit becomes as shown in Fig. 15.30 (b). The open-circuit voltage which appears across terminals A and B represents the Thevenin voltage V_{th} . This voltage equals the drop across Z_2 because there is no current flow through Z_3 .

Current flowing through Z_1 and Z_2 is

$$I = V/(Z_1 + Z_2) = 10 \angle 0^\circ / [(8 + j8) + (8 - j8)] = 10 \angle 0^\circ / 16 = 0.625 \angle 0^\circ$$

$$V_{th} = IZ_2 = 0.625 (8 - j8) = (5 - j5) = 7.07 \angle -45^\circ$$

The Thevenin impedance Z_{th} is equal to the impedance as viewed from open terminals A and B with voltage source shorted.

$$\therefore Z_{th} = Z_3 + Z_1 \parallel Z_2 = (2 + j20) + (8 + j8) \parallel (8 - j8) = (10 + j20)$$

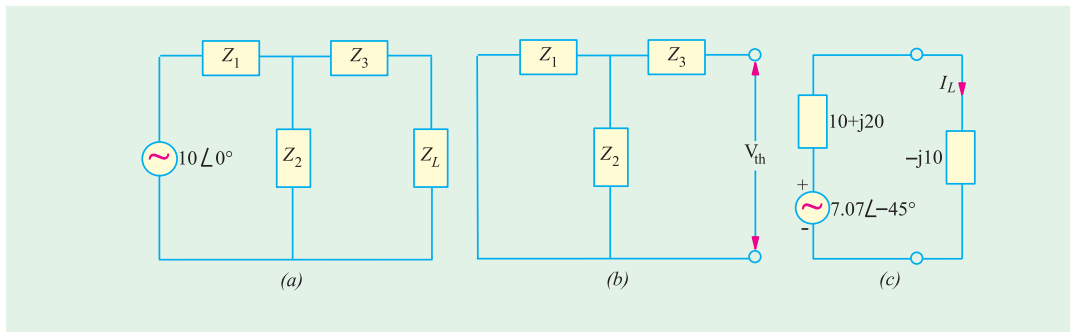

Fig. 15.30

The equivalent Thevenin circuit is shown in Fig. 15.30 (c) across which the load impedance has been reconnected. The load current is given by

$$\therefore I_L = \frac{V_{th}}{Z_{th} + Z_L} = \frac{(5 - j5)}{(10 + j20) + (-j10)} = \frac{-j}{2}$$

Example 15.13 A. Find the Thevenin equivalent circuit at terminals AB of the circuit given in Fig. 15.31 (a).

Solution. For finding $V_{th} = V_{AB}$, we have to find the phasor sum of the voltages available on the way as we go from point B to point A because V_{AB} means voltage of point A with respect to that of point B (Art.). The value of current $I = 100 \angle 0^\circ / (6 - j8) = (6 + j8)A$.

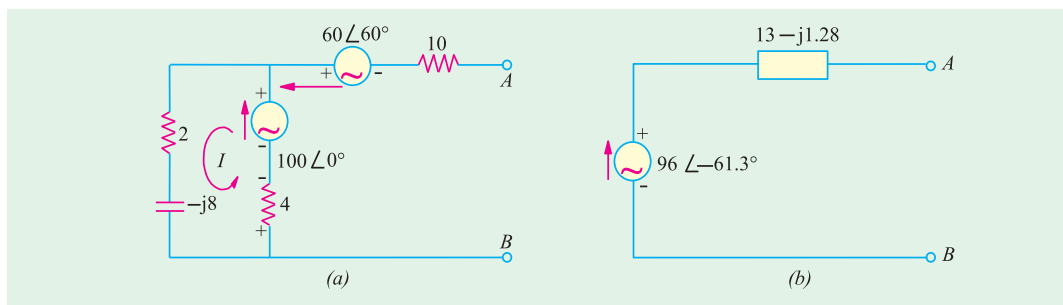

Fig. 15.31

Drop across $4\ \Omega$ resistor $= 4(6 + j8) = (24 + j32)$

$$\begin{aligned} \therefore V_{th} &= V_{AB} = -(24 + j32) + (100 + j0) - 60(0.5 + j0.866) \\ &= 46 - j84 = 96 \angle -61.3^\circ \end{aligned}$$

$$Z_{AB} = Z_{th} = [10 + [4 \parallel (2 - j8)]] = (13 - j1.28)$$

The Thevenin equivalent circuit is shown in Fig. 15.31 (b).

Example 15.14. Find the Thevenin's equivalent of the circuit shown in Fig. 15.32 and hence calculate the value of the current which will flow in an impedance of $(6 + j30)\ \Omega$ connected across terminals A and B. Also calculate the power dissipated in this impedance.

Solution. Let us first find the value of V_{th} i.e. the Thevenin voltage across open terminals A and B. With terminals A and B open, there is no potential drop across the capacitor. Hence, V_{th} is the drop across the pure inductor $j3$ ohm.

$$\text{Drop across the inductor} = \frac{10 + j0}{4 + j3} \times j3 = \frac{j30}{4 + j3} = \frac{j30(4 - j3)}{4^2 + 3^2} = (3.6 + j4.8)V$$

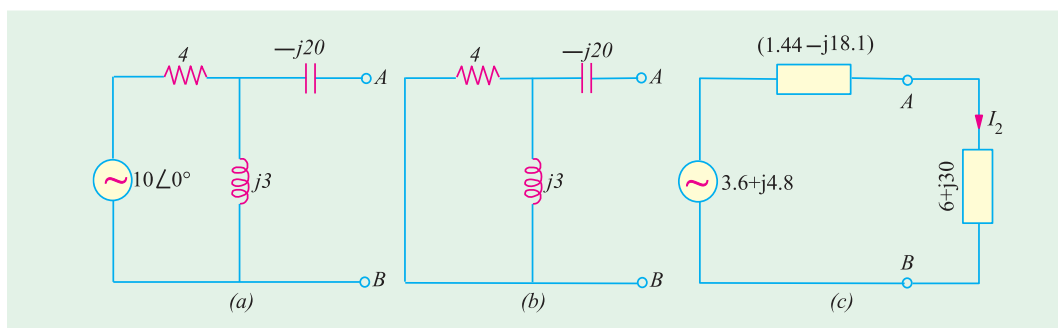

Fig. 15.32

Let us now find the impedance of the circuit as viewed from terminals A and B after replacing the voltage source by a short circuit as shown in Fig. 15.32 (a).

$$Z_{th} = -j20 + 4 \parallel j3 = -j20 + 1.44 + j1.92 = 1.44 - j18.1$$

The equivalent Thevenin circuit along with the load impedance of $(6 + j30)$ is shown in Fig. 15.32 (c).

$$\text{Load current} = \frac{(3.6 + j4.8)}{(1.44 - j18.1) + (6 + j30)} = \frac{(3.6 + j4.8)}{(7.44 + j11.9)} = \frac{6 \angle 53.1^\circ}{14 \angle 58^\circ} = 0.43 \angle -4.9^\circ$$

The current in the load is 0.43 A and lags the supply voltage by 4.9°

Power in the load impedance is $0.43^2 \times 6 = 1.1\ \text{W}$

Example 15.15. Using Thevenin's theorem, calculate the current flowing through the load connected across terminals A and B of the circuit shown in Fig. 15.33 (a). Also calculate the power delivered to the load.

Solution. The first step is to remove the load from the terminals A and B. $V_{th} = V_{AB}$ = drop across $(10 + j10)$ ohm with A and B open.

$$\begin{aligned} \text{Circuit current } I &= \frac{100}{-j10 + 10 + j10} = 10 \angle 0^\circ \\ \therefore V_{th} &= 10(10 + j10) = 141.4 \angle 45^\circ \\ Z_{th} &= (-j10) \parallel (10 + j10) = (10 - j10) \end{aligned}$$

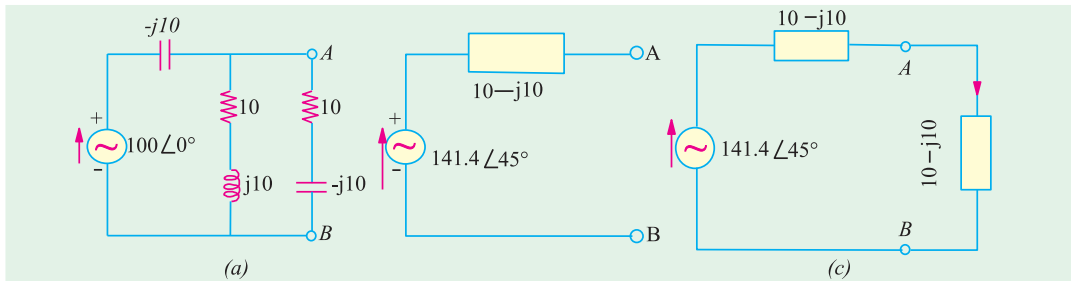

Fig. 15.33

The equivalent Thevenin's source is shown in Fig. 15.33 (b). Let the load be re-connected across A and B shown in Fig. 15.33 (c).

$$\begin{aligned} \therefore I_L &= \frac{141.4 \angle 45^\circ}{(10 - j10) + (10 - j10)} = \frac{141.4 \angle 45^\circ}{20 - j20} = \frac{141.4 \angle 45^\circ}{28.3 \angle -45^\circ} = 5 \angle 90^\circ \\ \text{Power delivered to the load} &= I_L^2 R_L = 5^2 \times 10 = 250 \text{ W} \end{aligned}$$

Example 15.16. Find the Thevenin's equivalent across terminals A and B of the networks shown in Fig. 15.34. (a).

Solution. The solution of this circuit involves the following steps :

(i) Let us find the equivalent Thevenin voltage V_{CD} and Thevenin impedance Z_{CD} as viewed from terminals C and D.

$$\begin{aligned} V_{CD} &= V \frac{Z_2}{Z_1 + Z_2} = \frac{100 \angle 0^\circ \times 20 \angle -30^\circ}{10 \angle 30^\circ + 20 \angle -30^\circ} = 75.5 \angle 19.1^\circ \text{ V} \\ Z_{CD} &= Z_1 \parallel Z_2 = \frac{10 \angle 30^\circ \times 20 \angle -30^\circ}{10 \angle 30^\circ + 20 \angle -30^\circ} = 7.55 \angle 10.9^\circ \text{ ohm} \end{aligned}$$

(ii) Using the source conversion technique (Art) we will replace the $5 \angle 0^\circ$ current source by a voltage source as shown in Fig. 15.34 (b).

$$V_{EC} = 5 \angle 0^\circ \times 10 \angle -30^\circ = 50 \angle -30^\circ$$

Its series resistance is the same as $Z_3 = 10 \angle -30^\circ$ as shown in Fig. 15.34 (b).

The polarity of the voltage source is such that it sends current in the direction EC, as before.

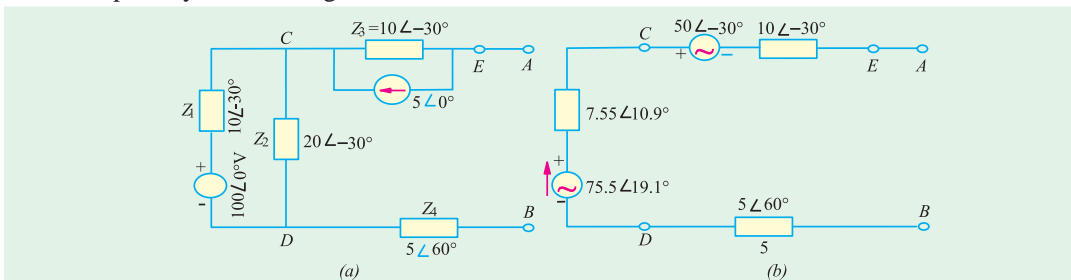

Fig. 15.34

(iii) From the above information, we can find V_{th} and Z_{th}

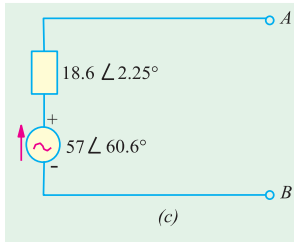

Fig. 15.34

$$V_{th} = V_{CD} = 75.5\angle 19.1^\circ - 50\angle 30^\circ = 57\angle 60.6^\circ$$

$$Z_{th} = Z_{CD} = 10\angle -30^\circ + 7.55\angle 10.9^\circ + 5\angle 60^\circ = 18.6\angle 2.25^\circ$$

The Thevenin equivalent with respect to the terminals A and B is shown in Fig. 15.34 (c).

For finding V_{AB} i.e. voltage at point A with respect to point B, we start from point B in Fig. 15.34 (b) and go to point A and calculate the phasor sum of the voltages met on the way.

$$\therefore V_{AB} = 75.1\angle 19.1^\circ - 50\angle 30^\circ = 57\angle 60.6^\circ$$

$$Z_{AB} = 10\angle 30^\circ + 7.55\angle 10.9^\circ + 5\angle 60^\circ = 18.6\angle 2.25^\circ$$

Example 15.17. For the network shown, determine using Thevenin's theorem, voltage across capacitor in Fig. 15.35. (Elect. Network Analysis Nagpur Univ. 1993)

$Z_{CD} = j5 \parallel (10 + j5) = 1.25 + j3.75$. This impedance is in series with the 10Ω resistance. Using voltage divider rule, the drop over Z_{CD} is

Solution. When load of $j5\Omega$ is removed the circuit becomes as shown in Fig. 15.35 (b). Thevenin voltage is given by the voltage drop produced by 100-V source over $(5 + j5)$ impedance. It can be calculated as under.

$$V_{CD} = 100 \frac{(1.25 + j3.75)}{10 + (1.25 + j3.75)} = \frac{125 + j375}{11.25 + j3.75}$$

This V_{CD} is applied across $j5$ reactance as well as across the series combination of 5Ω and $(5 + j5)\Omega$. Again, using voltage-divider rule for V_{CD} , we get

$$V_{AB} = V_{th} = V_{CD} \times \frac{5 + j5}{10 + j5} = \frac{(125 + j375)}{11.25 + j3.75} \times \frac{5 + j5}{10 + j5} = 21.1\angle 71.57^\circ = 6.67 + j20$$

As looked into terminals A and B, the equivalent impedance is given by

$$R_{AB} = R_{th} = (5 + j5) \parallel (5 + 10 \parallel j5) = (5 + j5) \parallel (7 + j4) = 3 + j2.33$$

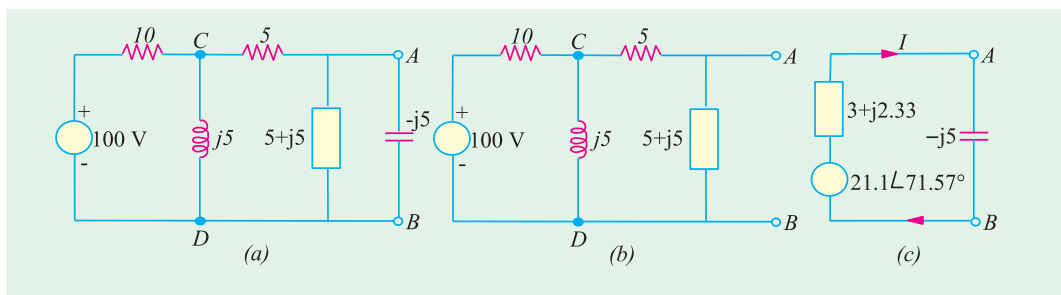

Fig. 15.35

The equivalent Thevenin's source along with the load is shown in Fig. 15.35 (c).

$$\text{Total impedance} = 3 + j2.33 - j5 = 3 - j2.67 = 4.02\angle -41.67^\circ$$

$$\therefore I = 21.1\angle 71.57^\circ / 4.02\angle -41.67^\circ = 5.25\angle 113.24^\circ$$

Solution by Mesh Resistance Matrix

The different items of the mesh resistance matrix $[R_m]$ are as under :

$$R_{11} = 10 + j5; R_{22} = 10 + j10; R_{33} = 5;$$

$$R_{12} = R_{21} = -j5;$$

$R_{23} = R_{32} = -(5 + j5)$; $R_{31} = R_{13} = 0$. Hence, the mesh equations in the matrix form are as given below :

$$\begin{bmatrix} (10 + j5) & -j5 & 0 \\ -j5 & (10 + j10) & -(5 + j5) \\ 0 & -(5 + j5) & 5 \end{bmatrix} = \begin{bmatrix} I_1 \\ I_2 \\ I_3 \end{bmatrix} = \begin{bmatrix} 100 \\ 0 \\ 0 \end{bmatrix}$$

$$\therefore \Delta = (10 + j5) [5(10 + j10) - (5 + j5)(5 + j5)] + j5(-j25) = 625 + j250 = 673 \angle 21.8^\circ$$

$$\begin{bmatrix} (10 + j5) & -j5 & 100 \\ -j5 & (10 + j10) & 0 \\ 0 & -(5 + j5) & 0 \end{bmatrix} = j5(500 + j500) = 3535 \angle 135^\circ$$

$$\therefore I_3 = \Delta_3 / \Delta = 3535 \angle 135^\circ / 673 \angle 21.8^\circ = 5.25 \angle 113.2^\circ$$

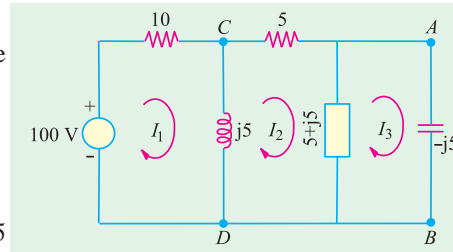

Fig. 15.36

Tutorial Problems No. 15.5

1. Determine the Thevenin's equivalent circuit with respect to terminals AB of the circuit shown in Fig. 15.37. $[V_{th} = 14.3 \angle 6.38^\circ; Z_m = (4 + j0.55) \Omega]$

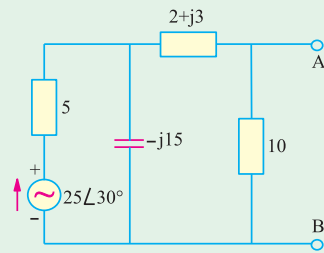

Fig. 15.37

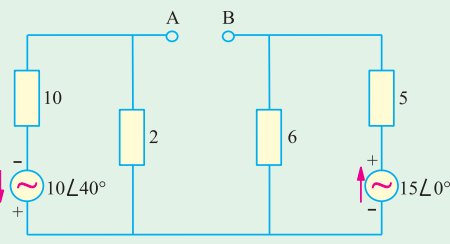

Fig. 15.38

2. Determine Thevenin's equivalent circuit with respect to terminals AB in Fig. 15.38. $[V_{th} = 9.5 \angle 6.46^\circ; Z_{th} = 4.4 \angle 0^\circ]$
3. The e.m.f.s. of two voltage source shown in Fig. 15.39 are in phase with each other. Using Thevenin's theorem, find the current which will flow in a 16 Ω resistor connected across terminals A and B. $[V_{th} = 100 \text{ V}; Z_{th} = (48 + j32); I = 1.44 \angle -26.56^\circ]$

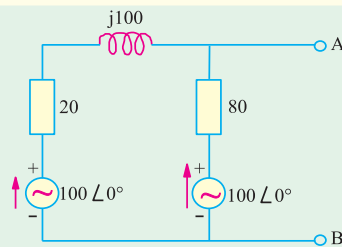

Fig. 15.39

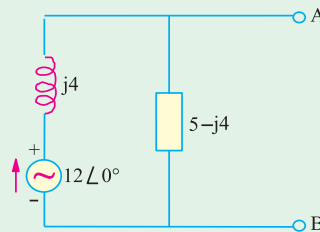

Fig. 15.40

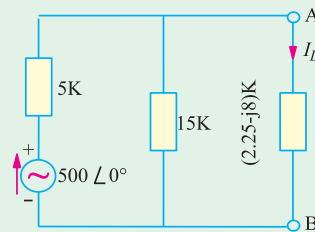

Fig. 15.41

4. Find the Thevenin's equivalent circuit for terminals AB for the circuit shown in Fig. 15.40. $[V_{th} = 15.37 \angle 38.66^\circ; Z_{th} = (3.2 + j4) \Omega]$
5. Using Thevenin's theorem, find the magnitude of the load current I_L passing through the load connected across terminals AB of the circuit shown in Fig. 15.41. $[37.5 \text{ mA}]$

6. By using Thevenin's theorem, calculate the current flowing through the load connected across terminals A and B of circuit shown in Fig. 15.42. All resistances and reactances are in ohms.

$[V_{th} = 56.9 \angle 50.15^\circ ; 3.11 \angle 85.67^\circ]$

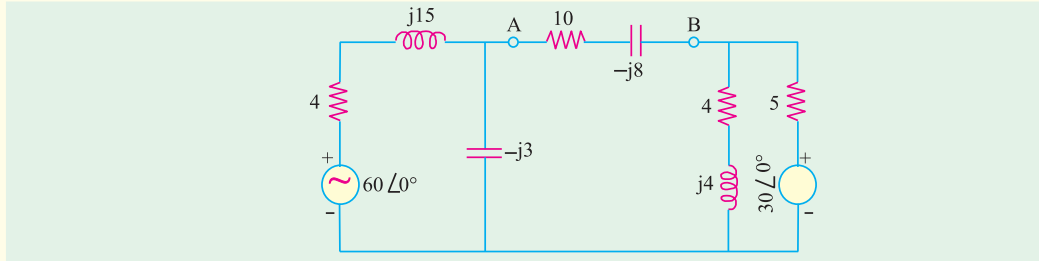

Fig. 15.42

7. Calculate the equivalent Thevenin's source with respect to the terminals A and B of the circuit shown in Fig. 15.43.
 8. What is the Thevenin's equivalent source with respect to the terminals A and B of the circuit shown in Fig. 15.44 ?

$[V_{th} = (6.34 + j2.93) \text{ V} ; Z_{th} = (3.17 - j5.07) \Omega]$

$[V_{th} = (9.33 + j8) \text{ V} ; Z_{th} = (8 - j11) \Omega]$

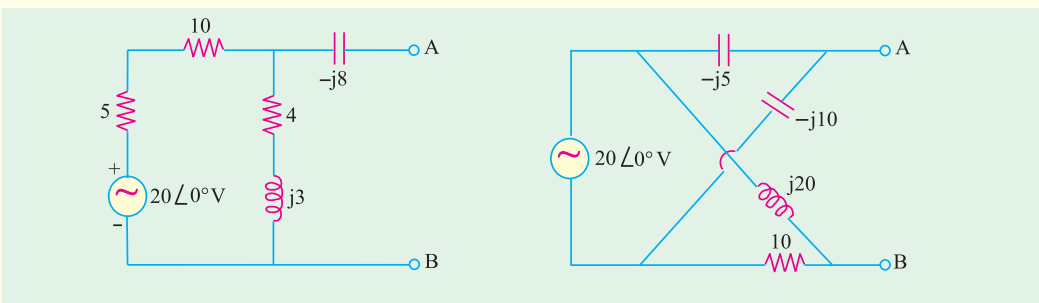

Fig. 15.43

Fig. 15.44

9. What is the Thevenin's equivalent source with respect to terminals A and B the circuit shown in Fig. 15.45 ? Also, calculate the value of impedance which should be connected across AB for MPT. All resistances and reactances are in ohms.

$[V_{th} = (16.87 + j15.16) \text{ V} ; Z_{th} = (17.93 - j1.75) \Omega ; (17.93 + j1.75) \Omega]$

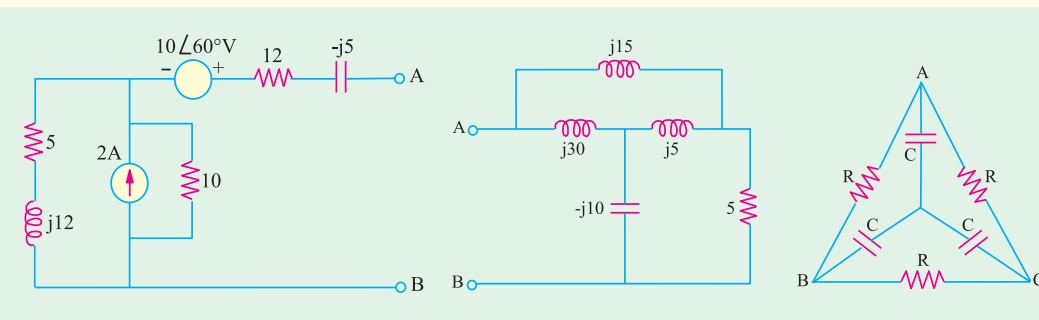

Fig. 15.45

Fig. 15.46

Fig. 15.47

10. Find the impedance of the network shown in Fig. 15.46, when viewed from the terminals A and B. All resistances and reactances are in ohms.
 11. Find the value of the impedance that would be measured across terminals BC of the circuit shown in Fig. 15.47.

$[(4.435 + j6.878)]$

$$\left[\frac{2R}{9 + \omega^2 C^2 R^2} (3 - j\omega CR) \right]$$

15.7. Reciprocity Theorem

This theorem applies to networks containing linear bilateral elements and a single voltage source or a single current source. This theorem may be stated as follows :

If a voltage source in branch A of a network causes a current of 1 branch B , then shifting the voltage source (but not its impedance) of branch B will cause the same current I in branch A .

It may be noted that currents in other branches will generally not remain the same. A simple way of stating the above theorem is that if an ideal voltage source and an ideal ammeter are inter-changed, the ammeter reading would remain the same. The ratio of the input voltage in branch A to the output current in branch B is called the transfer impedance.

Similarly, if a current source between nodes 1 and 2 causes a potential difference of V between nodes 3 and 4, shifting the current source (but not its admittance) to nodes 3 and 4 causes the same voltage V between nodes 1 and 2.

In other words, the interchange of an ideal current source and an ideal voltmeter in any linear bilateral network does not change the voltmeter reading.

However, the voltages between other nodes would generally not remain the same. The ratio of the input current between one set of nodes to output voltage between another set of nodes is called the transfer admittance.

Example 15.18. Verify Reciprocity theorem for V & I in the circuit shown in Fig. 15.48.

[Elect. Network Analysis, Nagpur Univ. 1993]

Solution. We will find the value of the current I as read by the ammeter first by applying series parallel circuits technique and then by using mesh resistance matrix (Art.)

1. Series Parallel Circuit Technique

The total impedance as seen by the voltage source is

$$= 1 + [j1 \parallel (2 - j1)] = 1 + \frac{j1(2 - j1)}{2} = 1.5 + j1$$

$$\therefore \text{total circuit current } i = \frac{5 \angle 0^\circ}{1.5 + j1}$$

This current gets divided into two parts at point A , one part going through the ammeter and the other going along AB . By using current-divider rule. (Art), we have

$$I = \frac{5}{1.5 + j1} \times \frac{j1}{(2 + j1 - j1)} = \frac{j5}{3 + j2}$$

2. Mesh Resistance Matrix

In Fig. 15.48 (b), $R_{11} = (1 + j1)$, $R_{22} = (2 + j1 - j1) = 2$; $R_{12} = R_{21} = -j1$

$$\therefore \begin{vmatrix} (1+j1) & -j1 \\ -j1 & 2 \end{vmatrix} \begin{vmatrix} I_1 \\ I_2 \end{vmatrix} = \begin{vmatrix} 5 \\ j0 \end{vmatrix}; \Delta = 2(1+j1) - (-j1)(-j1) = 3 + j2$$

$$\Delta_2 = \begin{vmatrix} (1+j1) & 5 \\ -j1 & 0 \end{vmatrix} = 0 + j5 = j5; I_2 = I = \frac{\Delta_2}{\Delta} = \frac{j5}{(3 + j2)}$$

As shown in Fig. 15.48 (c), the voltage source has been interchanged with the ammeter. The polarity of the voltage source should be noted in particular. It looks as if the voltage source has been pushed along the wire in the counterclockwise direction to its new position, thus giving the voltage polarity as shown in the figure. We will find the value of I in the new position of the ammeter by using the same two techniques as above.

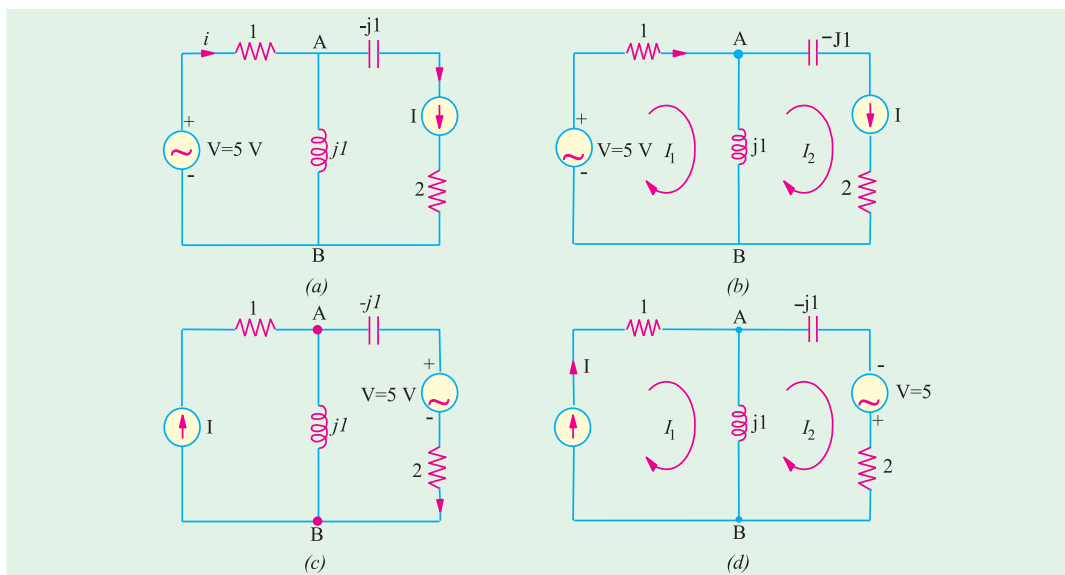

Fig. 15.48

1. Series Parallel Circuit Technique

As seen by the voltage source from its new position, the total circuit impedance is

$$= 2(2 - j1) + j1 \parallel 1 = \frac{3 + j2}{1 + j1}$$

The total circuit current $i = 5 \times \frac{1 + j1}{3 + j2}$

This current i gets divided into two parts at point B as per the current-divider rule.

$$I = \frac{5(1 + j1)}{3 + j2} \times j \frac{1}{1 + j1} = \frac{j5}{3 + j2}$$

2. Mesh Resistance Matrix

As seen from Fig. 15.48 (d).

$$\begin{vmatrix} (1 + j1) & -j1 \\ -j1 & 2 \end{vmatrix} \begin{vmatrix} I_1 \\ I_2 \end{vmatrix} = \begin{vmatrix} 0 \\ 5 \end{vmatrix}; \Delta = 2(1 + j1) + 1 = 3 + j2$$

$$\Delta = \begin{vmatrix} 0 & -j1 \\ 5 & 2 \end{vmatrix} = j5; I = I_1 = \frac{\Delta_1}{\Delta} = \frac{j5}{3 + j2}$$

The reciprocity theorem stands verified from the above results.

Tutorial problem No. 15.6

- State reciprocity theorem. Verify for the circuit Fig. 15.49, with the help of any suitable current through any element.
(Elect. Network Analysis Nagpur Univ. 1993)

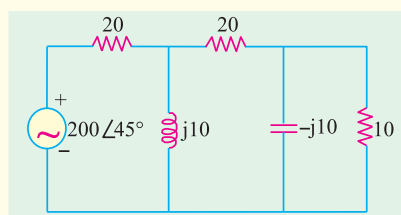

Fig. 15.49

15.8. Norton's Theorem

As applied to a.c. networks, this theorem can be stated as under :

Any two terminal active linear network containing voltage sources and impedances when viewed from its output terminals is equivalent to a constant current source and a parallel impedance. The constant current is equal to the current which would flow in a short-circuit placed across the terminals and the parallel impedance is the impedance of the network when viewed from open-circuited terminals after voltage sources have been replaced by their internal impedances (if any) and current sources by infinite impedance.

Example 15.19. Find the Norton's equivalent of the circuit shown in Fig. 15.50. Also find the current which will flow through an impedance of $(10 - j20) \Omega$ across the terminals A and B.

Solution. As shown in Fig. 15.50 (b), the terminals A and B have been short-circuited.

$$\therefore I_{SC} = I_N = 25 / (10 + j20) = 25 / 22.36 \angle 63.4^\circ = 1.118 \angle -63.4^\circ$$

When voltage source is replaced by a short, then the internal resistance of the circuit, as viewed from open terminals A and B, is $R_N = (10 + j20) \Omega$. Hence, Norton's equivalent circuit becomes as shown in Fig. 15.50(c).

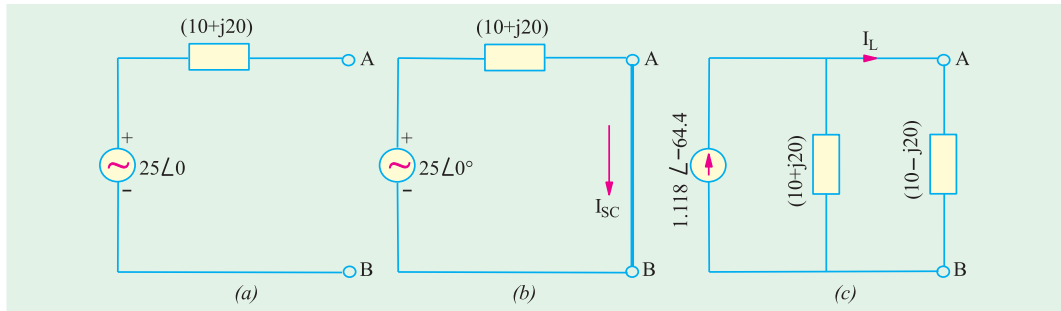

Fig. 15.50

When the load impedance of $(10 - j20)$ is applied across the terminals A and B, current through it can be found with the help of current-divider rule.

$$\therefore I_L = 1.118 \angle -63.4^\circ \times \frac{(10 + j20)}{(10 + j20) + (10 - j20)} = 1.25 \text{ A}$$

Example 15.20. Use Norton's theorem to find current in the load connected across terminals A and B of the circuit shown in Fig. 15.51 (a).

Solution. The first step is to short-circuit terminals A and B as shown in Fig. 15.51 (a)*. The short across A and B not only short-circuits the load but the $(10 + j10)$ impedance as well.

$$I_N = 100 \angle 0^\circ / (j10) = j10 = 10 \angle 90^\circ$$

Since the impedance of the Norton and Thevenin equivalent circuits is the same, $Z_N = 10 - j10$.

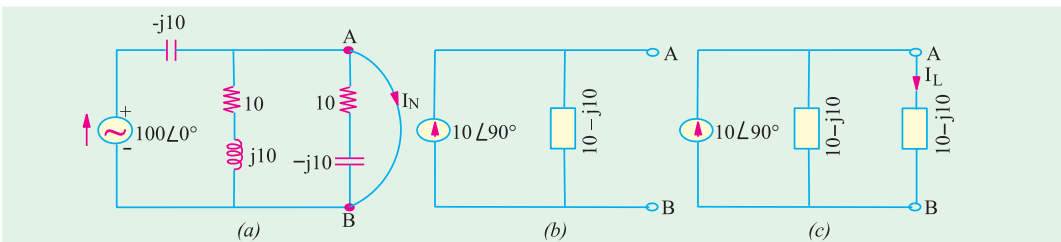

Fig. 15.51

* For finding I_N , we may or may not remove the load from the terminals (because, in either case, it would be short-circuited) but for finding R_N , it has to be removed as in the case of Thevenin's theorem.

The Norton's equivalent circuit is shown in Fig. 15.51 (b). In Fig. 15.51 (c), the load has been reconnected across the terminals A and B. Since the two impedances are equal, current through each is half of the total current *i.e.* $10\angle 90^\circ/2 = 5\angle 90^\circ$.

Tutorial Problems No. 15.7

1. Find the Norton's equivalent source with respect to terminals A and B of the networks shown in Fig. 15.51 (a) (b). All resistances and reactances are expressed in siemens in Fig. 15.51 (a) and in ohms in Fig. 15.52.

$$[(a) I_N = -(2.1 - j3) \text{ A}; 1/Z_N = (0.39 + j0.3) \text{ S} \quad (b) I_N = (6.87 + j0.5) \text{ A}; 1/Z_N = (3.17 + j1.46) \text{ S}]$$

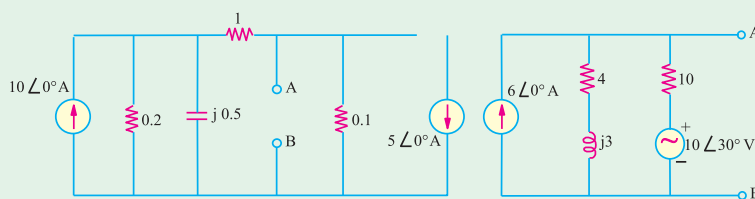

Fig. 15.52

Fig. 15.53

2. Find the Norton's equivalent source with respect to terminals A and B for the circuit shown in Fig. 15.54. Hence, find the voltage V_L across the $100\ \Omega$ load and check its result by using Millman's theorem. All resistances are in ohms.

$$[I_N = 9 \text{ A}; Y_N = 0.15 \text{ S}; V_L = 56.25 \angle 0^\circ]$$

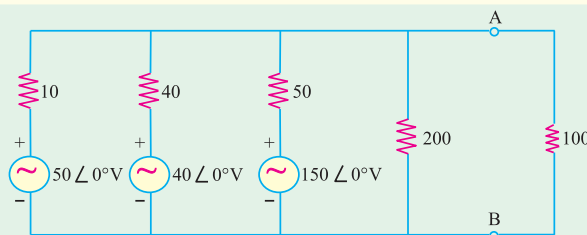

Fig. 15.54

3. Find the Norton's equivalent network at terminals AB of the circuit shown in Fig. 15.55.

$$[I_{SC} = 2.17 \angle 44^\circ \text{ A}; Z_N = (2.4 + j1.47) \ \Omega]$$

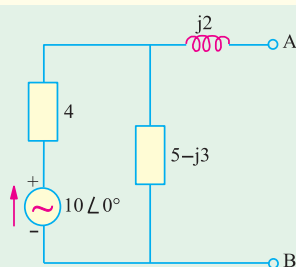

Fig. 15.55

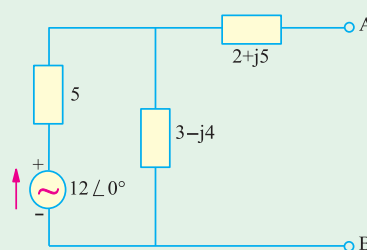

Fig. 15.56

4. What is the Norton equivalent circuit at terminals AB of the network shown in Fig. 15.56

$$[I_{SC} = 1.15 \angle -66.37^\circ \text{ A}; Z_N = (4.5 + j3.75) \ \Omega]$$

15.9. Maximum Power Transfer Theorem

As explained earlier in Art. this theorem is particularly useful for analysing communication networks where the goal is transfer of maximum power between two circuits and not highest efficiency.

15.10. Maximum Power Transfer Theorems - General Case

We will consider the following maximum power transfer theorems when the source has a fixed complex impedance and delivers power to a load consisting of a variable resistance or a variable complex impedance.

Case 1. When load consists only for a variable resistance R_L [Fig. 15.57 (a)]. The circuit current is

$$I = \frac{V_g}{\sqrt{(R_g + R_L)^2 + X_g^2}}$$

$$\text{Power delivered to } R_L \text{ is } P_L = \frac{V_g^2 R_L}{(R_g + R_L)^2 + X_g^2}$$

To determine the value of R_L for maximum transfer of power, we should set the first derivative dP_L/dR_L to zero.

$$\frac{dP_L}{dR_L} = \frac{d}{dR_L} \left[\frac{V_g^2 R_L}{(R_g + R_L)^2 + X_g^2} \right] = V_g^2 \left\{ \frac{[(R_g + R_L)^2 + X_g^2] - R_L(2)(R_g + R_L)}{[(R_g + R_L)^2 + X_g^2]^2} \right\} = 0$$

$$\text{or } R_g^2 + 2R_g R_L + R_L^2 + X_g^2 - 2R_L R_g - 2R_L^2 = 0 \text{ and } R_g^2 + X_g^2 = R_L^2$$

$$\therefore R_L = \sqrt{R_g^2 + X_g^2} = |Z_g|$$

It means that with a variable pure resistive load, maximum power is delivered across the terminals of an active network only when the load resistance is equal to the absolute value of the impedance of the active network. Such a match is called magnitude match.

Moreover, if X_g is zero, then for maximum power transfer $R_L = R_g$

Case 2. Load impedance having both variable resistance and variable reactance [Fig. 15.57 (b)].

$$\text{The circuit current is } I = \frac{V_g}{\sqrt{(R_g + R_L)^2 + (X_g + X_L)^2}}$$

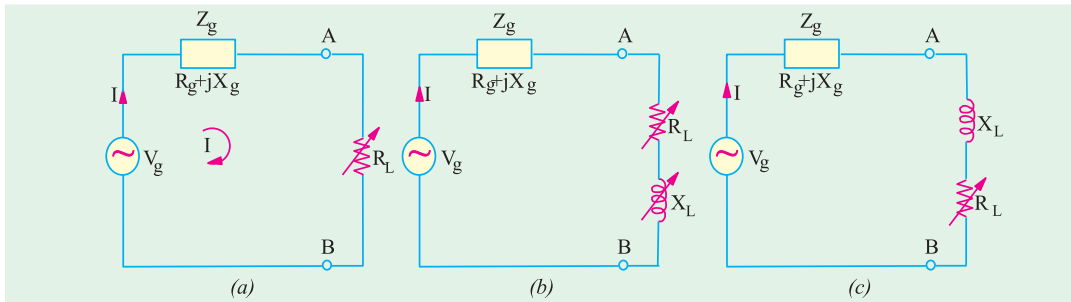

Fig. 15.57

$$\text{The power delivered to the load is } P_L = I^2 R_L = \frac{V_g^2 R_L}{(R_g + R_L)^2 + (X_g + X_L)^2}$$

$$\text{Now, if } R_L \text{ is held fixed, } P_L \text{ is maximum when } X_g = -X_L. \text{ In that case } P_{Lmax} = \frac{V_g^2 R_L}{(R_g + R_L)^2}$$

If on the other hand, R_L is variable then, as in **Case 1** above, maximum power is delivered to the load when $R_L = R_g$. In that case if $R_L = R_g$ and $X_L = -X_g$, then $Z_L = Z_g$. Such a match is called conjugate match.

From the above, we come to the conclusion that in the case of a load impedance having both variable resistance and variable reactance, maximum power transfer across the terminals of the active network occurs when Z_L equals the complex conjugate of the network impedance Z_g i.e. the two impedances are conjugately matched.

Case 3. Z_L with variable resistance and fixed reactance [Fig. 15.57 (c)]. The equations for current I and power P_L are the same as in **Case 2** above except that we will consider X_L to remain constant. When the first derivative of P_L with respect to R_L is set equal to zero, it is found that

$$R_L^2 = R_g^2 + (X_g + X_L)^2 \text{ and } R_L = |Z_g + jX_L|$$

Since Z_g and X_L are both fixed quantities, these can be combined into a single impedance. Then with R_L variable, **Case 3** is reduced to **Case 1** and the maximum power transfer takes place when R_L equals the absolute value of the network impedance.

Summary

The above facts can be summarized as under :

1. When load is purely resistive and adjustable, MPT is achieved when $R_L = |Z_g| = \sqrt{R_g^2 + X_g^2}$.
2. When both load and source impedances are purely resistive (i.e. $X_L = X_g = 0$), MPT is achieved when $R_L = R_g$.
3. When R_L and X_L are both independently adjustable, MPT is achieved when $X_L = -X_g$ and $R_L = R_g$.
4. When X_L is fixed and R_L is adjustable, MPT is achieved when $R_L = \sqrt{[R_g^2 + (X_g + X_L)^2]}$

Example 15.21. In the circuit of Fig. 15.58, which load impedance of p.f. = 0.8 lagging when connected across terminals A and B will draw the maximum power from the source. Also find the power developed in the load and the power loss in the source.

Solution. For maximum power transfer $|Z_L| = |Z_1| = \sqrt{3^2 + 5^2} = 5.83 \Omega$

For p.f. = 0.8, $\cos \phi = 0.8$ and $\sin \phi = 0.6$.

$$\therefore R_L = Z_L \cos \phi = 5.83 \times 0.8 = 4.66 \Omega$$

$$X_L = Z_L \sin \phi = 5.83 \times 0.6 = 3.5 \Omega$$

$$\text{Total circuit impedance } Z = \sqrt{[(R_1 + R_L)^2 + (X_1 + X_L)^2]}$$

$$= \sqrt{[(3 + 4.66)^2 + (5 + 3.5)^2]} = 11.44 \Omega$$

$$\therefore I = V/Z = 20/11.44 = 1.75 \text{ A.}$$

$$\text{Power in the load} = I^2 R_L = 1.75^2 \times 4.66 = 14.3 \text{ W}$$

$$\text{Power loss in the source} = 1.75^2 \times 3 = 9.2 \text{ W.}$$

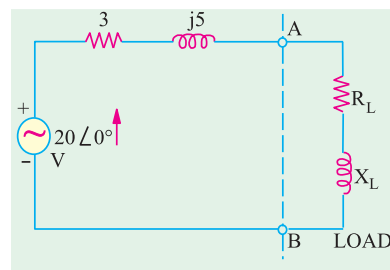

Fig. 15.58

Example 15.22. In the network shown in Fig. 15.59 find the value of load to be connected across terminals AB consisting of variable resistance R_L and capacitive reactance X_C which would result in maximum power transfer. (Network Analysis, Nagpur Univ. 1993)

Solution. We will first find the Thevenin's equivalent circuit between terminals A and B. When the load is removed, the circuit become as shown in Fig. 15.59 (b).

$$\begin{aligned} V_{th} &= \text{drop across } (2 + j10) = 50 \angle 45^\circ \times \frac{2 + j10}{7 + j10} \\ &= 41.8 \times 68.7^\circ = 15.2 + j38.9 \\ R_{th} &= 5 \parallel (2 + j10) = 4.1 \angle 23.7^\circ = 3.7 + j1.6 \end{aligned}$$

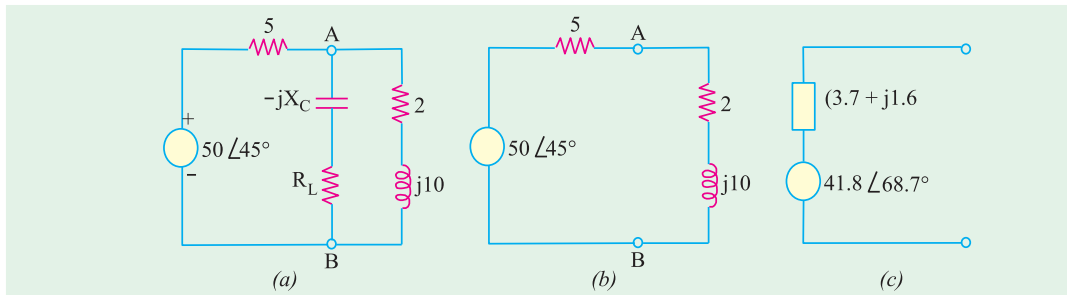

Fig. 15.59

The Thevenin's equivalent source is shown in Fig. 15.59 (c)

Since for MPT, conjugate match is required hence, $X_C = 1.6 \Omega$ and $R_L = 3.7 \Omega$

Tutorial Problem No. 15.8

1. In the circuit of Fig. 15.60 the load consists of a fixed inductance having a reactance of $j10 \Omega$ and a variable load resistor R_L . Find the value of R_L for MPT and the value of this power.

[58.3 Ω ; 46.2 W]

2. In the circuit of Fig. 15.61, the source resistance R_g is variable between 5Ω and 50Ω but R_L has a fixed value of 25Ω . Find the value of R_g for which maximum power is dissipated in the load and the value of this power.

[5 Ω ; 250 W]

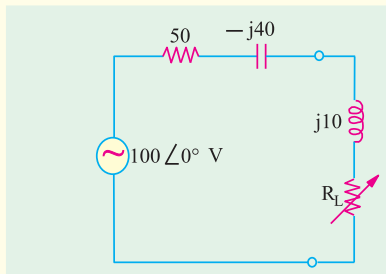

Fig. 15.60

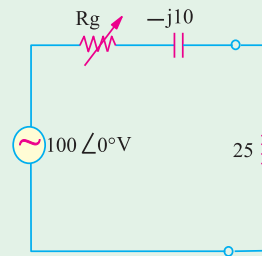

Fig. 15.61

15.11. Millman's Theorem

It permits any number of parallel branches consisting of voltage sources and impedances to be reduced to a single equivalent voltage source and equivalent impedance. Such multi-branch circuits are frequently encountered in both electronics and power applications.

Example 15.23. By using Millman's theorem, calculate node voltage V and current in the $j6$ impedance of Fig. 15.62.

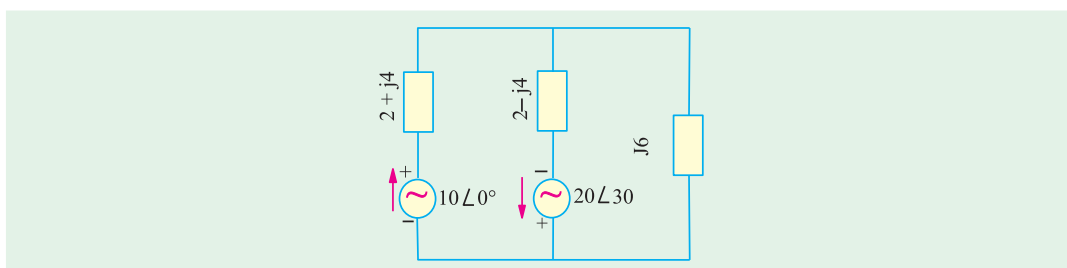

Fig. 15.62

Solution. According to Millman's theorem as applicable to voltage sources.

$$V = \frac{\pm V_1 Y_1 \pm V_2 Y_2 \pm V_3 Y_3 \pm \dots \pm V_n Y_n}{Y_1 + Y_2 + Y_3 + \dots + Y_n}$$

$$Y_1 = \frac{1}{2 + j4} = \frac{2 - j4}{20} = 0.01 - j0.02 = 0.022 \angle -63.4^\circ$$

$$Y_2 = \frac{1}{2 - j4} = \frac{2 + j4}{20} = 0.01 + j0.02 = 0.022 \angle 63.4^\circ$$

$$Y_3 = \frac{1}{j6} = 0.167 \angle 90^\circ = 0 - j0.167$$

$$Y_1 + Y_2 + Y_3 = 0.02 - j0.167$$

In the present case, $V_3 = 0$ and also $V_2 Y_2$ would be taken as negative because current due to V_2 flows away from the node.

$$\begin{aligned} \therefore V &= \frac{V_1 Y_1 - V_2 Y_2}{Y_1 + Y_2 + Y_3} = \frac{10 \angle 0^\circ \times 0.022 \angle -63.4^\circ - 20 \angle 30^\circ \times 0.022 \angle 63.4^\circ}{0.02 - j0.167} \\ &= 3.35 \angle 177^\circ \end{aligned}$$

$$\text{Current through } j6 \text{ impedance} = 3.35 \angle 177^\circ / 6 \angle 90^\circ = 0.56 \angle 87^\circ$$

Tutorial Problems No. 15.9

1. With the help of Millman's theorem, calculate the voltage across the 1 K resistor in the circuit of Fig. 15.63.

[2.79 V]

2. Using Millman's theorem, calculate the voltage V_{ON} in the 3-phase circuit shown in Fig. 15.64. All load resistances and reactances are in milli-siemens.

[$V_{ON} = 69.73 \angle 113.53^\circ$]

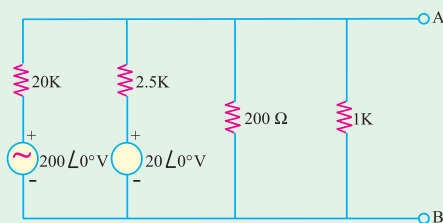

Fig. 15.63

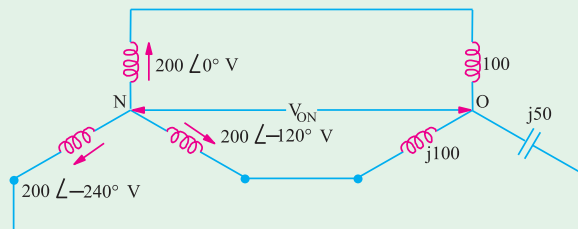

Fig. 15.64

3. Define mesh current and node voltage. (Madras University, April 2002)
4. State superposition theorem. (Madras University, April 2002)
5. State Millman's theorem. (Madras University, April 2002)
6. Two circuits the impedances of which are given by $Z_1 = (10 + j15)\Omega$ and $Z_2 = (6 - j8)\Omega$ are connected in parallel. If the total current supplied is 15 A. What is the power taken by each branch? (RGPV Bhopal 2002)

OBJECTIVE TYPES – 15

1. The Thevenin's equivalent resistance R_{th} for the given network is

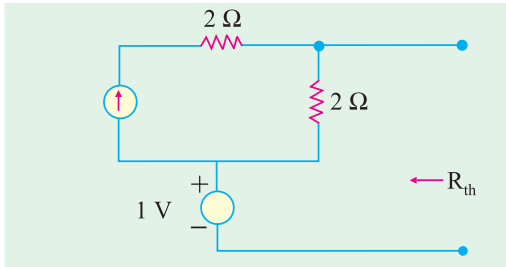

Fig. 15.65

- (a) 1 Ω
 (b) 2 Ω
 (c) 4 Ω
 (d) infinity

2. The Norton's equivalent of circuit shown in Figure 15.66 is drawn in the circuit shown in Figure 15.67. The values of I_{SC} and R_{eq} in Figure II are respectively

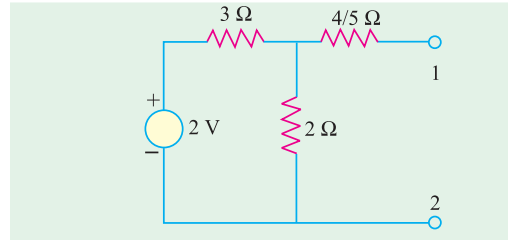

Fig. 15.66

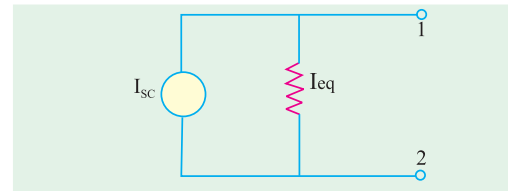

Fig. 15.67

- (a) $\frac{5}{2}$ A and 2 Ω (b) $\frac{2}{5}$ A and 1 Ω
 (c) $\frac{4}{5}$ A and $\frac{12}{5}$ Ω (d) $\frac{2}{5}$ A and 2 Ω