

CHAPTER 1

Learning Objectives

- Electron Drift Velocity
- Charge Velocity and Velocity of Field Propagation
- The Idea of Electric Potential Resistance
- Unit of Resistance
- Law of Resistance
- Units of Resistivity Conductance and Conductivity
- Temperature Coefficient of Resistance
- Value of α at Different Temperatures
- Variation of Resistivity with Temperature
- Ohm's Law
- Resistance in Series
- Voltage Divider Rule
- Resistance in Parallel
- Types of Resistors
- Nonlinear Resistors
- Varistor
- Short and Open Circuits
- 'Shorts' in a Series Circuit
- 'Opens' in Series Circuit
- 'Open's in a Parallel Circuit
- 'Shorts' in Parallel Circuits
- Division of Current in Parallel Circuits
- Equivalent Resistance
- Duality Between Series and Parallel Circuits
- Relative Potential
- Voltage Divider Circuits

ELECTRIC CURRENT AND OHM'S LAW



Ohm's law defines the relationship between voltage, resistance and current. This law is widely employed while designing electronic circuits

1.1. Electron Drift Velocity

Suppose that in a conductor, the number of free electrons available per m^3 of the conductor material is n and let their axial drift velocity be v metres/second. In time dt , distance travelled would be $v \times dt$. If A is area of cross-section of the conductor, then the volume is $vAdt$ and the number of electrons contained in this volume is $vAdt$. Obviously, all these electrons will cross the conductor cross-section in time dt . If e is the charge of each electron, then total charge which crosses the section in time dt is $dq = nAev dt$.

Since current is the rate of flow of charge, it is given as

$$i = \frac{dq}{dt} = \frac{nAev dt}{dt} \quad \therefore i = nAev$$

Current density, $J = i/A = nev$ ampere/metre²

Assuming a normal current density $J = 1.55 \times 10^6 \text{ A/m}^2$, $n = 10^{29}$ for a copper conductor and $e = 1.6 \times 10^{-19}$ coulomb, we get

$$1.55 \times 10^6 = 10^{29} \times 1.6 \times 10^{-19} \times v \quad \therefore v = 9.7 \times 10^{-5} \text{ m/s} = 0.58 \text{ cm/min}$$

It is seen that contrary to the common but mistaken view, the electron drift velocity is rather very slow and is independent of the current flowing and the area of the conductor.

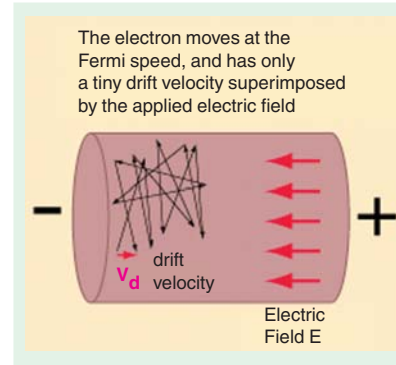

N.B. Current density *i.e.*, the current per unit area, is a vector quantity. It is denoted by the symbol \vec{J} .

Therefore, in vector notation, the relationship between current I and \vec{J} is :

$$I = \vec{J} \cdot \vec{a} \quad [\text{where } \vec{a} \text{ is the vector notation for area 'a'}]$$

For extending the scope of the above relationship, so that it becomes applicable for area of any shape, we write :

$$I = \int \vec{J} \cdot d\vec{a}$$

The magnitude of the current density can, therefore, be written as $J \cdot \alpha$.

Example 1.1. A conductor material has a free-electron density of 10^{24} electrons per metre³. When a voltage is applied, a constant drift velocity of 1.5×10^{-2} metre/second is attained by the electrons. If the cross-sectional area of the material is 1 cm^2 , calculate the magnitude of the current. Electronic charge is 1.6×10^{-19} coulomb. **(Electrical Engg. Aligarh Muslim University)**

Solution. The magnitude of the current is

$$i = nAev \text{ amperes}$$

Here,

$$n = 10^{24}; A = 1 \text{ cm}^2 = 10^{-4} \text{ m}^2$$

$$e = 1.6 \times 10^{-19} \text{ C}; v = 1.5 \times 10^{-2} \text{ m/s}$$

$$\therefore i = 10^{24} \times 10^{-4} \times 1.6 \times 10^{-19} \times 1.5 \times 10^{-2} = \mathbf{0.24 \text{ A}}$$

1.2. Charge Velocity and Velocity of Field Propagation

The speed with which charge drifts in a conductor is called the **velocity of charge**. As seen from above, its value is quite low, typically fraction of a metre per second.

However, the *speed* with which the effect of e.m.f. is experienced at all parts of the conductor resulting in the flow of current is called the **velocity of propagation of electrical field**. It is independent of current and voltage and has high but constant value of nearly $3 \times 10^8 \text{ m/s}$.

Example 1.2. Find the velocity of charge leading to 1 A current which flows in a copper conductor of cross-section 1 cm^2 and length 10 km. Free electron density of copper = 8.5×10^{28} per m^3 . How long will it take the electric charge to travel from one end of the conductor to the other?

Solution. $i = neAv$ or $v = i/neA$

$$\therefore v = 1/(8.5 \times 10^{28} \times 1.6 \times 10^{-19} \times 1 \times 10^{-4}) = 7.35 \times 10^{-7} \text{ m/s} = \mathbf{0.735 \mu\text{m/s}}$$

Time taken by the charge to travel conductor length of 10 km is

$$t = \frac{\text{distance}}{\text{velocity}} = \frac{10 \times 10^3}{7.35 \times 10^{-7}} = 1.36 \times 10^{10} \text{ s}$$

Now, 1 year = $365 \times 24 \times 3600 = 31,536,000$ s

$$t = 1.36 \times 10^{10}/31,536,000 = \mathbf{431 \text{ years}}$$

1.3. The Idea of Electric Potential

In Fig. 1.1, a simple voltaic cell is shown. It consists of copper plate (known as anode) and a zinc rod (*i.e.* cathode) immersed in dilute sulphuric acid (H_2SO_4) contained in a suitable vessel. The chemical action taking place within the cell causes the electrons to be removed from copper plate and to be deposited on the zinc rod at the same time. This transfer of electrons is accomplished through the agency of the diluted H_2SO_4 which is known as the electrolyte. The result is that zinc rod becomes negative due to the deposition of electrons on it and the copper plate becomes positive due to the removal of electrons from it. The large number of electrons collected on the zinc rod is being attracted by anode but is prevented from returning to it by the force set up by the chemical action within the cell.

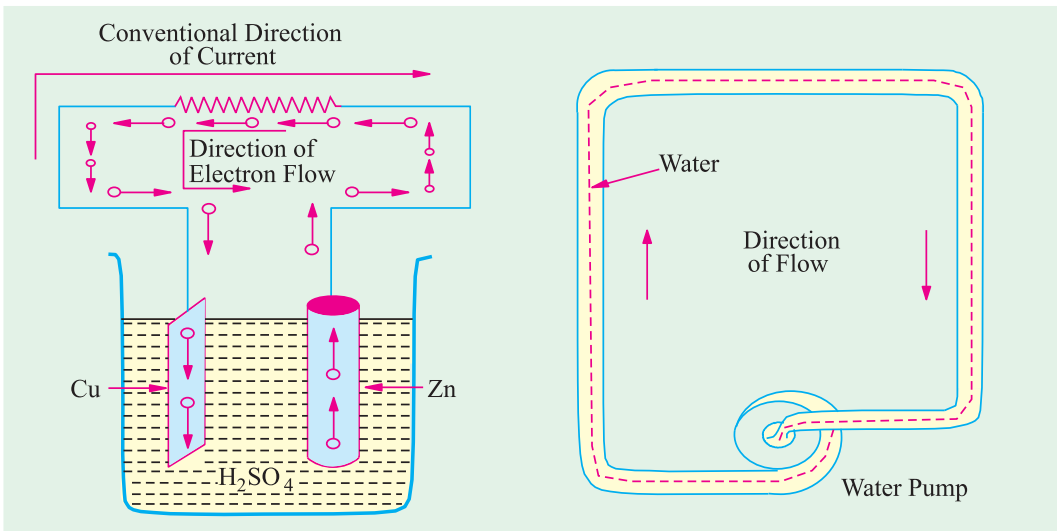

Fig. 1.1.

Fig. 1.2

But if the two electrodes are joined by a wire *externally*, then electrons rush to the anode thereby equalizing the charges of the two electrodes. However, due to the continuity of chemical action, a continuous difference in the number of electrons on the two electrodes is maintained which keeps up a continuous flow of current through the external circuit. The action of an electric cell is similar to that of a water pump which, while working, maintains a continuous flow of water *i.e.*, water current through the pipe (Fig. 1.2).

It should be particularly noted that the direction of *electronic* current is from zinc to copper in the external circuit. However, the direction of *conventional* current (which is given by the direction

of flow of positive charge) is from copper to zinc. In the present case, there is no flow of positive charge as such from one electrode to another. But we can look upon the arrival of electrons on copper plate (with subsequent decrease in its positive charge) as equivalent to an actual departure of positive charge from it.

When zinc is negatively charged, it is said to be at negative potential with respect to the electrolyte, whereas anode is said to be at positive potential relative to the electrolyte. Between themselves, copper plate is assumed to be at a higher potential than the zinc rod. The difference in potential is continuously maintained by the chemical action going on in the cell which supplies energy to establish this potential difference.

1.4. Resistance

It may be defined as the property of a substance due to which it opposes (or restricts) the flow of electricity (*i.e.*, electrons) through it.

Metals (as a class), acids and salts solutions are good conductors of electricity. Amongst pure metals, silver, copper and aluminium are very good conductors in the given order.* This, as discussed earlier, is due to the presence of a large number of free or loosely-attached electrons in their atoms. These vagrant electrons assume a directed motion on the application of an electric potential difference. These electrons while flowing pass *through* the molecules or the atoms of the conductor, collide and other atoms and electrons, thereby producing heat.

Those substances which offer relatively greater difficulty or hindrance to the passage of these electrons are said to be relatively poor conductors of electricity like bakelite, mica, glass, rubber, p.v.c. (polyvinyl chloride) and dry wood etc. Amongst good insulators can be included fibrous substances such as paper and cotton when dry, mineral oils free from acids and water, ceramics like hard porcelain and asbestos and many other plastics besides p.v.c. It is helpful to remember that electric friction is similar to friction in Mechanics.

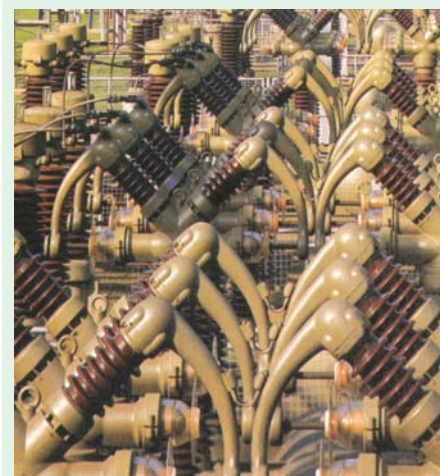

Cables are often covered with materials that do not carry electric current easily

1.5. The Unit of Resistance

The practical unit of resistance is ohm.** A conductor is said to have a resistance of one ohm if it permits one ampere current to flow through it when one volt is impressed across its terminals.

For insulators whose resistances are very high, a much bigger unit is used *i.e.*, mega-ohm = 10^6 ohm (the prefix 'mega' or mego meaning a million) or kilo-ohm = 10^3 ohm (kilo means thousand). In the case of very small resistances, smaller units like milli-ohm = 10^{-3} ohm or micro-ohm = 10^{-6} ohm are used. The symbol for ohm is Ω



George Simon Ohm

* However, for the same resistance per unit length, cross-sectional area of aluminium conductor has to be 1.6 times that of the copper conductor but it weighs only half as much. Hence, it is used where economy of weight is more important than economy of space.

** After George Simon Ohm (1787-1854), a German mathematician who in about 1827 formulated the law known after his name as Ohm's Law.

Table 1.1. Multiples and Sub-multiples of Ohm

Prefix	Its meaning	Abbreviation	Equal to
Mega-	One million	M Ω	$10^6 \Omega$
Kilo-	One thousand	k Ω	$10^3 \Omega$
Centi-	One hundredth	–	–
Milli-	One thousandth	m Ω	$10^{-3} \Omega$
Micro-	One millionth	$\mu \Omega$	$10^{-6} \Omega$

1.6. Laws of Resistance

The resistance R offered by a conductor depends on the following factors :

- (i) It varies directly as its length, l .
- (ii) It varies inversely as the cross-section A of the conductor.
- (iii) It depends on the nature of the material.
- (iv) It also depends on the temperature of the conductor.

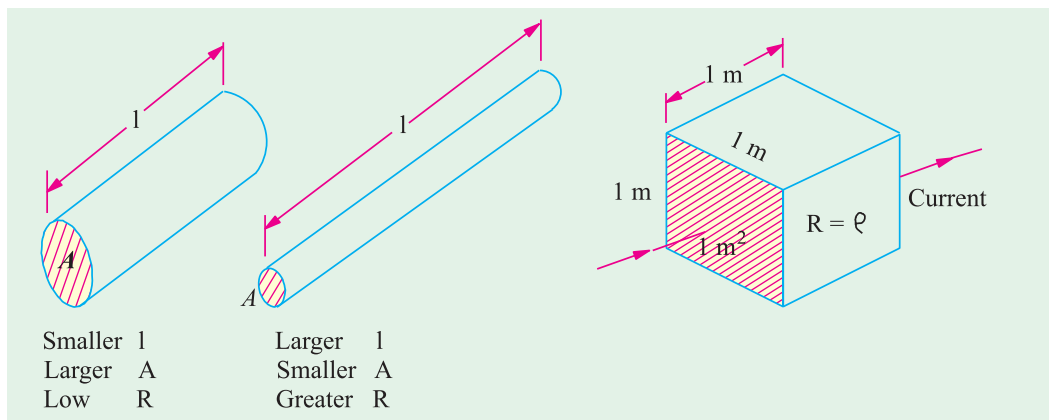

Fig. 1.3.

Fig. 1.4

Neglecting the last factor for the time being, we can say that

$$R \propto \frac{l}{A} \quad \text{or} \quad R = \rho \frac{l}{A} \quad \dots(i)$$

where ρ is a constant depending on the nature of the material of the conductor and is known as its **specific resistance or resistivity**.

If in Eq. (i), we put

$$l = 1 \text{ metre} \quad \text{and} \quad A = 1 \text{ metre}^2, \text{ then } R = \rho \quad (\text{Fig. 1.4})$$

Hence, specific resistance of a material may be defined as **the resistance between the opposite faces of a metre cube of that material**.

1.7. Units of Resistivity

From Eq. (i), we have

$$\rho = \frac{AR}{l}$$

In the S.I. system of units,

$$\rho = \frac{A \text{ metre}^2 \times R \text{ ohm}}{l \text{ metre}} = \frac{AR}{l} \text{ ohm-metre}$$

Hence, the unit of resistivity is ohm-metre ($\Omega\text{-m}$).

It may, however, be noted that resistivity is sometimes expressed as so many ohm per m^3 . Although, it is incorrect to say so but it means the same thing as ohm-metre.

If l is in centimetres and A in cm^2 , then ρ is in ohm-centimetre ($\Omega\text{-cm}$).

Values of resistivity and temperature coefficients for various materials are given in Table 1.2. The resistivities of commercial materials may differ by several per cent due to impurities etc.

Table 1.2. Resistivities and Temperature Coefficients

<i>Material</i>	<i>Resistivity in ohm-metre at 20°C ($\times 10^{-8}$)</i>	<i>Temperature coefficient at 20°C ($\times 10^{-4}$)</i>
Aluminium, commercial	2.8	40.3
Brass	6 – 8	20
Carbon	3000 – 7000	–5
Constantan or Eureka	49	+0.1 to –0.4
Copper (annealed)	1.72	39.3
German Silver (84% Cu; 12% Ni; 4% Zn)	20.2	2.7
Gold	2.44	36.5
Iron	9.8	65
Manganin (84% Cu ; 12% Mn ; 4% Ni)	44 – 48	0.15
Mercury	95.8	8.9
Nichrome (60% Cu ; 25% Fe ; 15% Cr)	108.5	1.5
Nickel	7.8	54
Platinum	9 – 15.5	36.7
Silver	1.64	38
Tungsten	5.5	47
Amber	5×10^{14}	
Bakelite	10^{10}	
Glass	$10^{10} - 10^{12}$	
Mica	10^{15}	
Rubber	10^{16}	
Shellac	10^{14}	
Sulphur	10^{15}	

Example 1.3. A coil consists of 2000 turns of copper wire having a cross-sectional area of 0.8 mm^2 . The mean length per turn is 80 cm and the resistivity of copper is $0.02 \mu\Omega\text{-m}$. Find the resistance of the coil and power absorbed by the coil when connected across 110 V d.c. supply.

(F.Y. Engg. Pune Univ. May 1990)

Solution. Length of the coil, $l = 0.8 \times 2000 = 1600 \text{ m}$;
 $A = 0.8 \text{ mm}^2 = 0.8 \times 10^{-6} \text{ m}^2$.

$$R = \rho \frac{l}{A} = 0.02 \times 10^{-6} \times 1600 / 0.8 \times 10^{-6} = \mathbf{40 \Omega}$$

$$\text{Power absorbed} = V^2 / R = 110^2 / 40 = \mathbf{302.5 \text{ W}}$$



Example 1.4. An aluminium wire 7.5 m long is connected in a parallel with a copper wire 6 m long. When a current of 5 A is passed through the combination, it is found that the current in the aluminium wire is 3 A. The diameter of the aluminium wire is 1 mm. Determine the diameter of the copper wire. Resistivity of copper is $0.017 \mu\Omega\text{-m}$; that of the aluminium is $0.028 \mu\Omega\text{-m}$.

(F.Y. Engg. Pune Univ. May 1991)

Solution. Let the subscript 1 represent aluminium and subscript 2 represent copper.

$$R_1 = \rho \frac{l_1}{a_1} \text{ and } R_2 = \rho_2 \frac{l_2}{a_2} \quad \therefore \frac{R_2}{R_1} = \frac{\rho_2}{\rho_1} \cdot \frac{l_2}{l_1} \cdot \frac{a_1}{a_2}$$

$$\therefore a_2 = a_1 \cdot \frac{R_1}{R_2} \cdot \frac{\rho_2}{\rho_1} \cdot \frac{l_2}{l_1} \quad \dots(i)$$

Now

$$I_1 = 3 \text{ A} ; I_2 = 5 - 3 = 2 \text{ A.}$$

If V is the common voltage across the parallel combination of aluminium and copper wires, then

$$V = I_1 R_1 = I_2 R_2 \quad \therefore R_1 / R_2 = I_2 / I_1 = 2/3$$

$$a_1 = \frac{\pi d^2}{4} = \frac{\pi \times 1^2}{4} = \frac{\pi}{4} \text{ mm}^2$$

Substituting the given values in Eq. (i), we get

$$a_2 = \frac{\pi}{4} \times \frac{2}{3} \times \frac{0.017}{0.028} \times \frac{6}{7.5} = 0.2544 \text{ m}^2$$

$$\therefore \pi \times d_2^2 / 4 = 0.2544 \quad \text{or} \quad d_2 = \mathbf{0.569 \text{ mm}}$$

Example 1.5. (a) A rectangular carbon block has dimensions $1.0 \text{ cm} \times 1.0 \text{ cm} \times 50 \text{ cm}$.
(i) What is the resistance measured between the two square ends ? **(ii)** between two opposing rectangular faces / Resistivity of carbon at 20°C is $3.5 \times 10^{-5} \Omega\text{-m}$.

(b) A current of 5 A exists in a $10\text{-}\Omega$ resistance for 4 minutes **(i)** how many coulombs and **(ii)** how many electrons pass through any section of the resistor in this time ? Charge of the electron = $1.6 \times 10^{-19} \text{ C}$.

(M.S. Univ. Baroda)

Solution.

(a) (i)

$$R = \rho l / A$$

Here,

$$A = 1 \times 1 = 1 \text{ cm}^2 = 10^{-4} \text{ m}^2 ; l = 0.5 \text{ m}$$

\therefore

$$R = 3.5 \times 10^{-5} \times 0.5 / 10^{-4} = \mathbf{0.175 \Omega}$$

(ii) Here,

$$l = 1 \text{ cm} ; A = 1 \times 50 = 50 \text{ cm}^2 = 5 \times 10^{-3} \text{ m}^2$$

$$R = 3.5 \times 10^{-5} \times 10^2 / 5 \times 10^{-3} = \mathbf{7 \times 10^{-5} \Omega}$$

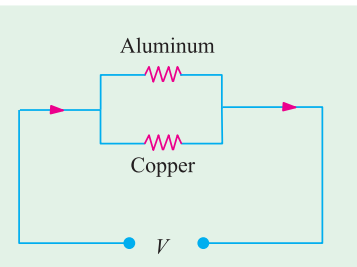

$$(b) (i) \quad Q = It = 5 \times (4 \times 60) = 1200 \text{ C}$$

$$(ii) \quad n = \frac{Q}{e} = \frac{1200}{1.6 \times 10^{-19}} = 75 \times 10^{20}$$

Example 1.6. Calculate the resistance of 1 km long cable composed of 19 strands of similar copper conductors, each strand being 1.32 mm in diameter. Allow 5% increase in length for the 'lay' (twist) of each strand in completed cable. Resistivity of copper may be taken as $1.72 \times 10^{-8} \Omega\text{-m}$.

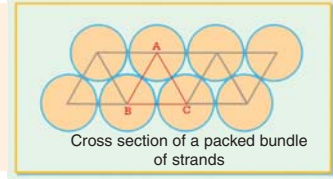

Solution. Allowing for twist, the length of the strands.
 $= 1000 \text{ m} + 5\% \text{ of } 1000 \text{ m} = 1050 \text{ m}$

Area of cross-section of 19 strands of copper conductors is
 $19 \times \pi \times d^2/4 = 19 \pi \times (1.32 \times 10^{-3})^2/4 \text{ m}^2$

$$\text{Now,} \quad R = \rho \frac{l}{A} = \frac{1.72 \times 10^{-8} \times 1050 \times 4}{19 \pi \times 1.32^2 \times 10^{-6}} = 0.694 \Omega$$

Example 1.7. A lead wire and an iron wire are connected in parallel. Their respective specific resistances are in the ratio 49 : 24. The former carries 80 percent more current than the latter and the latter is 47 percent longer than the former. Determine the ratio of their cross sectional areas.

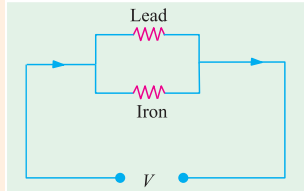

(Elect. Engg. Nagpur Univ. 1993)

Solution. Let suffix 1 represent lead and suffix 2 represent iron. We are given that

$$\rho_1/\rho_2 = 49/24; \text{ if } i_2 = 1, i_1 = 1.8; \text{ if } l_1 = 1, l_2 = 1.47$$

$$\text{Now,} \quad R_1 = \rho_1 \frac{l_1}{A_1} \quad \text{and} \quad R_2 = \rho_2 \frac{l_2}{A_2}$$

Since the two wires are in parallel, $i_1 = V/R_1$ and $i_2 = V/R_2$

$$\therefore \quad \frac{i_2}{i_1} = \frac{R_1}{R_2} = \frac{\rho_1 l_1}{\rho_2 l_2} \times \frac{A_2}{A_1}$$

$$\therefore \quad \frac{A_2}{A_1} = \frac{i_2}{i_1} \times \frac{\rho_2 l_2}{\rho_1 l_1} = \frac{1}{1.8} \times \frac{24}{49} \times 1.47 = 0.4$$

Example 1.8. A piece of silver wire has a resistance of 1 Ω . What will be the resistance of manganin wire of one-third the length and one-third the diameter, if the specific resistance of manganin is 30 times that of silver.

(Electrical Engineering-I, Delhi Univ.)

Solution. For silver wire, $R_1 = \frac{l_1}{A_1}$; For manganin wire, $R = \rho_2 \frac{l_2}{A_2}$

$$\therefore \quad \frac{R_2}{R_1} = \frac{\rho_2 \times l_2 \times A_1}{\rho_1 \times l_1 \times A_2}$$

$$\text{Now} \quad A_1 = \pi d_1^2/4 \quad \text{and} \quad A_2 = \pi d_2^2/4 \quad \therefore A_1/A_2 = d_1^2/d_2^2$$

$$\therefore \quad \frac{R_2}{R_1} = \frac{\rho_2 \times l_2 \times \left(\frac{d_1}{d_2}\right)^2}{\rho_1 \times l_1}$$

$$R_1 = 1 \Omega; \quad l_2/l_1 = 1/3, \quad (d_1/d_2)^2 = (3/1)^2 = 9; \quad \rho_2/\rho_1 = 30$$

$$\therefore \quad R_2 = 1 \times 30 \times (1/3) \times 9 = 90 \Omega$$

Example 1.9. The resistivity of a ferric-chromium-aluminium alloy is $51 \times 10^{-8} \Omega\text{-m}$. A sheet of the material is 15 cm long, 6 cm wide and 0.014 cm thick. Determine resistance between (a) opposite ends and (b) opposite sides. (Electric Circuits, Allahabad Univ.)

Solution. (a) As seen from Fig. 1.5 (a) in this case,

$$l = 15 \text{ cm} = 0.15 \text{ m}$$

$$A = 6 \times 0.014 = 0.084 \text{ cm}^2 \\ = 0.084 \times 10^{-4} \text{ m}^2$$

$$R = \rho \frac{l}{A} = \frac{51 \times 10^{-8} \times 0.15}{0.084 \times 10^{-4}} \\ = 9.1 \times 10^{-3} \Omega$$

(b) As seen from Fig. 1.5 (b) here

$$l = 0.014 \text{ cm} = 14 \times 10^{-5} \text{ m}$$

$$A = 15 \times 6 = 90 \text{ cm}^2 = 9 \times 10^{-3} \text{ m}^2$$

$$\therefore R = 51 \times 10^{-8} \times 14 \times 10^{-5} / 9 \times 10^{-3} = 79.3 \times 10^{-10} \Omega$$

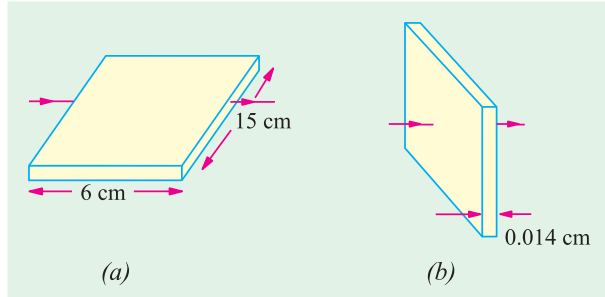

Fig. 1.5

Example 1.10. The resistance of the wire used for telephone is 35 Ω per kilometre when the weight of the wire is 5 kg per kilometre. If the specific resistance of the material is $1.95 \times 10^{-8} \Omega\text{-m}$, what is the cross-sectional area of the wire? What will be the resistance of a loop to a subscriber 8 km from the exchange if wire of the same material but weighing 20 kg per kilometre is used?

Solution. Here $R = 35 \Omega$, $l = 1 \text{ km} = 1000 \text{ m}$; $\rho = 1.95 \times 10^{-8} \Omega\text{-m}$

$$\text{Now, } R = \rho \frac{l}{A} \text{ or } A = \frac{\rho l}{R} \therefore A = \frac{1.95 \times 10^{-8} \times 1000}{35} = 55.7 \times 10^{-8} \text{ m}^2$$

If the second case, if the wire is of the material but weighs 20 kg/km, then its cross-section must be greater than that in the first case.

$$\text{Cross-section in the second case} = \frac{20}{5} \times 55.7 \times 10^{-8} = 222.8 \times 10^{-8} \text{ m}^2$$

$$\text{Length of wire} = 2 \times 8 = 16 \text{ km} = 16000 \text{ m} \therefore R = \rho \frac{l}{A} = \frac{1.95 \times 10^{-8} \times 16000}{222.8 \times 10^{-8}} = 140.1 \Omega$$

Tutorial Problems No. 1.1

- Calculate the resistance of 100 m length of a wire having a uniform cross-sectional area of 0.1 mm^2 if the wire is made of manganin having a resistivity of $50 \times 10^{-8} \Omega\text{-m}$.
If the wire is drawn out to three times its original length, by how many times would you expect its resistance to be increased? [500 Ω ; 9 times]
- A cube of a material of side 1 cm has a resistance of 0.001Ω between its opposite faces. If the same volume of the material has a length of 8 cm and a uniform cross-section, what will be the resistance of this length? [0.064 Ω]
- A lead wire and an iron wire are connected in parallel. Their respective specific resistances are in the ratio 49 : 24. The former carries 80 per cent more current than the latter and the latter is 47 per cent longer than the former. Determine the ratio of their cross-sectional area. [2.5 : 1]
- A rectangular metal strip has the following dimensions :
 $x = 10 \text{ cm}$, $y = 0.5 \text{ cm}$, $z = 0.2 \text{ cm}$
Determine the ratio of resistances R_x , R_y , and R_z between the respective pairs of opposite faces.
[$R_x : R_y : R_z : 10,000 : 25 : 4$] (Elect. Engg. A.M.Ae. S.I.)
- The resistance of a conductor 1 mm^2 in cross-section and 20 m long is 0.346Ω . Determine the specific resistance of the conducting material. [$1.73 \times 10^{-8} \Omega\text{-m}$] (Elect. Circuits-1, Bangalore Univ. 1991)
- When a current of 2 A flows for 3 micro-seconds in a copper wire, estimate the number of electrons crossing the cross-section of the wire. (Bombay University, 2000)

Hint : With 2 A for 3 μ Sec, charge transferred = 6 μ -coulombs

$$\text{Number of electrons crossed} = 6 \times 10^{-6} / (1.6 \times 10^{-19}) = 3.75 \times 10^{13}$$

1.8. Conductance and Conductivity

Conductance (G) is reciprocal of resistance*. Whereas resistance of a conductor measures the *opposition* which it offers to the flow of current, the conductance measures the *inducement* which it offers to its flow.

$$\text{From Eq. (i) of Art. 1.6, } R = \rho \frac{l}{A} \text{ or } G = \frac{1}{\rho} \cdot \frac{A}{l} = \frac{\sigma A}{l}$$

where σ is called the *conductivity or specific conductance* of a conductor. The unit of conductance is siemens (S). Earlier, this unit was called mho.

It is seen from the above equation that the conductivity of a material is given by

$$\sigma = G \frac{l}{A} = \frac{G \text{ siemens} \times l \text{ metre}}{A \text{ metre}^2} = G \frac{l}{A} \text{ siemens/metre}$$

Hence, the unit of conductivity is siemens/metre (S/m).

1.9. Effect of Temperature on Resistance

The effect of rise in temperature is :

- (i) to *increase* the resistance of pure metals. The increase is large and fairly regular for normal ranges of temperature. The temperature/resistance graph is a straight line (Fig. 1.6). As would be presently clarified, metals have a positive temperature co-efficient of resistance.
- (ii) to *increase* the resistance of alloys, though in their case, the increase is relatively small and irregular. For some high-resistance alloys like Eureka (60% Cu and 40% Ni) and manganin, the increase in resistance is (or can be made) negligible over a considerable range of temperature.
- (iii) to *decrease* the resistance of electrolytes, insulators (such as paper, rubber, glass, mica etc.) and partial conductors such as carbon. Hence, insulators are said to possess a *negative* temperature-coefficient of resistance.

1.10. Temperature Coefficient of Resistance

Let a metallic conductor having a resistance of R_0 at 0°C be heated of $t^\circ\text{C}$ and let its resistance at this temperature be R_t . Then, considering normal ranges of temperature, it is found that the increase in resistance $\Delta R = R_t - R_0$ depends

- (i) directly on its initial resistance
- (ii) directly on the rise in temperature
- (iii) on the nature of the material of the conductor.

$$\text{or } R_t - R_0 \propto R_0 \times t \text{ or } R_t - R_0 = \alpha R_0 t \quad \dots(i)$$

where α (alpha) is a constant and is known as the *temperature coefficient of resistance* of the conductor.

$$\text{Rearranging Eq. (i), we get } \alpha = \frac{R_t - R_0}{R_0 \times t} = \frac{\Delta R}{R_0 \times t}$$

$$\text{If } R_0 = 1 \Omega, t = 1^\circ\text{C, then } \alpha = \Delta R = R_t - R_0$$

Hence, the temperature-coefficient of a material may be defined as :

the increase in resistance per ohm original resistance per $^\circ\text{C}$ rise in temperature.

$$\text{From Eq. (i), we find that } R_t = R_0 (1 + \alpha t) \quad \dots(ii)$$

* In a.c. circuits, it has a slightly different meaning.

It should be remembered that the above equation holds good for both rise as well as fall in temperature. As temperature of a conductor is decreased, its resistance is also decreased. In Fig. 1.6 is shown the temperature/resistance graph for copper and is practically a straight line. If this line is extended backwards, it would cut the temperature axis at a point where temperature is -234.5°C (a number quite easy to remember). It means that theoretically, the resistance of copper conductor will become zero at this point though as shown by solid line, in practice, the curve departs from a straight line at very low temperatures. From the two similar triangles of Fig. 1.6 it is seen that :

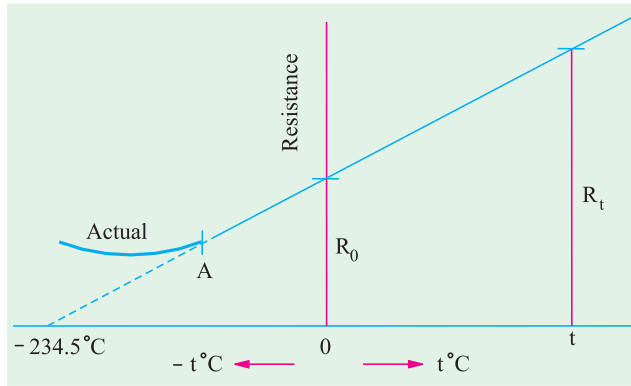

Fig. 1.6

$$\frac{R_t}{R_0} = \frac{t + 234.5}{234.5} = \left(1 + \frac{t}{234.5}\right)$$

$$\therefore R_t = R_0 \left(1 + \frac{t}{234.5}\right) \text{ or } R_t = R_0 (1 + \alpha t) \text{ where } \alpha = 1/234.5 \text{ for copper.}$$

1.11. Value of α at Different Temperatures

So far we did not make any distinction between values of α at different temperatures. But it is found that value of α itself is not constant but depends on the initial temperature on which the increment in resistance is based. When the increment is based on the resistance measured at 0°C , then α has the value of α_0 . At any other initial temperature $t^{\circ}\text{C}$, value of α is α_t and so on. It should be remembered that, for any conductor, α_0 has the maximum value.

Suppose a conductor of resistance R_0 at 0°C (point A in Fig. 1.7) is heated to $t^{\circ}\text{C}$ (point B). Its resistance R_t after heating is given by

$$R_t = R_0 (1 + \alpha_0 t) \quad \dots(i)$$

where α_0 is the temperature-coefficient at 0°C .

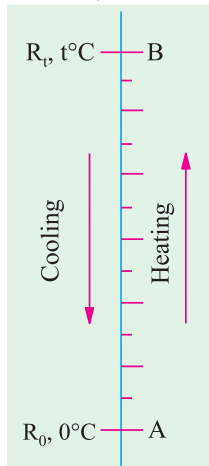

Fig. 1.7

Now, suppose that we have a conductor of resistance R_t at temperature $t^{\circ}\text{C}$. Let this conductor be **cooled** from $t^{\circ}\text{C}$ to 0°C . Obviously, now the initial point is B and the final point is A. The final resistance R_0 is given in terms of the initial resistance by the following equation

$$R_0 = R_t [1 + \alpha_t (-t)] = R_t (1 - \alpha_t \cdot t) \quad \dots(ii)$$

From Eq. (ii) above, we have $\alpha_t = \frac{R_t - R_0}{R_t \times t}$

Substituting the value of R_t from Eq. (i), we get

$$\alpha_t = \frac{R_0 (1 + \alpha_0 t) - R_0}{R_0 (1 + \alpha_0 t) \times t} = \frac{\alpha_0}{1 + \alpha_0 t} \therefore \alpha_t = \frac{\alpha_0}{1 + \alpha_0 t} \quad \dots(iii)$$

In general, let $\alpha_1 =$ tempt. coeff. at $t_1^{\circ}\text{C}$; $\alpha_2 =$ tempt. coeff. at $t_2^{\circ}\text{C}$. Then from Eq. (iii) above, we get

$$\alpha_1 = \frac{\alpha_0}{1 + \alpha_0 t_1} \quad \text{or} \quad \frac{1}{\alpha_1} = \frac{1 + \alpha_0 t_1}{\alpha_0}$$

Similarly,

$$\frac{1}{\alpha_2} = \frac{1 + \alpha_0 t_2}{\alpha_0}$$

Subtracting one from the other, we get

$$\frac{1}{\alpha_2} - \frac{1}{\alpha_1} = (t_2 - t_1) \quad \text{or} \quad \frac{1}{\alpha_2} = \frac{1}{\alpha_1} + (t_2 - t_1) \quad \text{or} \quad \alpha_2 = \frac{1}{1/\alpha_1 + (t_2 - t_1)}$$

Values of α for copper at different temperatures are given in Table No. 1.3.

Table 1.3. Different values of α for copper

Tempt. in °C	0	5	10	20	30	40	50
α	0.00427	0.00418	0.00409	0.00393	0.00378	0.00364	0.00352

In view of the dependence of α on the initial temperature, we may define *the temperature coefficient of resistance at a given temperature as the change in resistance per ohm per degree centigrade change in temperature from the given temperature.*

In case R_0 is not given, the relation between the known resistance R_1 at $t_1^\circ\text{C}$ and the unknown resistance R_2 at $t_2^\circ\text{C}$ can be found as follows :

$$R_2 = R_0 (1 + \alpha_0 t_2) \quad \text{and} \quad R_1 = R_0 (1 + \alpha_0 t_1)$$

$$\therefore \frac{R_2}{R_1} = \frac{1 + \alpha_0 t_2}{1 + \alpha_0 t_1} \quad \dots (iv)$$

The above expression can be simplified by a little approximation as follows :

$$\frac{R_2}{R_1} = (1 + \alpha_0 t_2) (1 + \alpha_0 t_1)^{-1}$$

$$= (1 + \alpha_0 t_2) (1 - \alpha_0 t_1)$$

$$= 1 + \alpha_0 (t_2 - t_1)$$

[Using Binomial Theorem for expansion and neglecting squares and higher powers of $(\alpha_0 t_1)$]

$$\therefore R_2 = R_1 [1 + \alpha_0 (t_2 - t_1)] \quad \text{[Neglecting product } (\alpha_0^2 t_1 t_2)]$$

For more accurate calculations, Eq. (iv) should, however, be used.

1.12. Variations of Resistivity with Temperature

Not only resistance but specific resistance or resistivity of metallic conductors also increases with rise in temperature and *vice-versa*.

As seen from Fig. 1.8 the resistivities of metals vary linearly with temperature over a significant range of temperature—the variation becoming non-linear both at very high and at very low temperatures. Let, for any metallic conductor,

$$\rho_1 = \text{resistivity at } t_1^\circ\text{C}$$

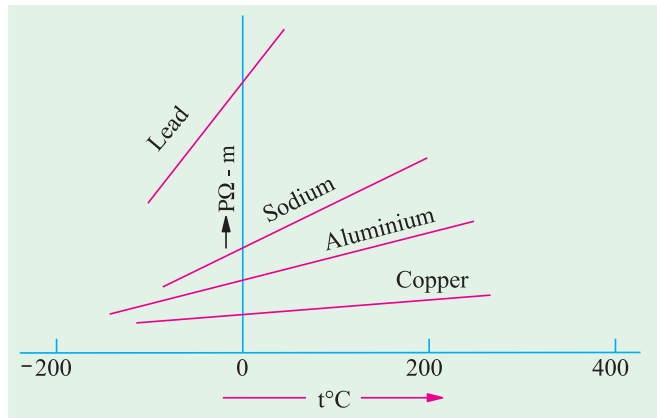

Fig. 1.8

ρ_2 = resistivity at $t_2^\circ\text{C}$

m = Slope of the linear part of the curve

Then, it is seen that

$$m = \frac{\rho_2 - \rho_1}{t_2 - t_1}$$

$$\text{or } \rho_2 = \rho_1 + m(t_2 - t_1) \quad \text{or} \quad \rho_2 = \rho_1 \left[1 + \frac{m}{\rho_1}(t_2 - t_1) \right]$$

The ratio of m/ρ_1 is called the **temperature coefficient of resistivity** at temperature $t_1^\circ\text{C}$. It may be defined as numerically equal to the fractional change in ρ_1 per $^\circ\text{C}$ change in the temperature from $t_1^\circ\text{C}$. It is almost equal to the temperature-coefficient of resistance α_1 . Hence, putting $\alpha_1 = m/\rho_1$, we get

$$\rho_2 = \rho_1 [1 + \alpha_1(t_2 - t_1)] \quad \text{or} \quad \text{simply as } \rho_t = \rho_0(1 + \alpha_0 t)$$

Note. It has been found that although temperature is the most significant factor influencing the resistivity of metals, other factors like pressure and tension also affect resistivity to some extent. For most metals except lithium and calcium, increase in pressure leads to decrease in resistivity. However, resistivity increases with increase in tension.

Example 1.11. A copper conductor has its specific resistance of 1.6×10^{-6} ohm-cm at 0°C and a resistance temperature coefficient of $1/254.5$ per $^\circ\text{C}$ at 20°C . Find (i) the specific resistance and (ii) the resistance - temperature coefficient at 60°C . (F.Y. Engg. Pune Univ. Nov.)

Solution. $\alpha_{20} = \frac{\alpha_0}{1 + \alpha_0 \times 20}$ or $\frac{1}{254.5} = \frac{\alpha_0}{1 + \alpha_0 \times 20} \quad \therefore \alpha_0 = \frac{1}{234.5}$ per $^\circ\text{C}$

(i) $\rho_{60} = \rho_0(1 + \alpha_0 \times 60) = 1.6 \times 10^{-6} (1 + 60/234.5) = 2.01 \times 10^{-6} \Omega\text{-cm}$

(ii) $\alpha_{60} = \frac{\alpha_0}{1 + \alpha_0 \times 60} = \frac{1/234.5}{1 + (60/234.5)} = \frac{1}{294.5}$ per $^\circ\text{C}$

Example 1.12. A platinum coil has a resistance of 3.146Ω at 40°C and 3.767Ω at 100°C . Find the resistance at 0°C and the temperature-coefficient of resistance at 40°C .

(Electrical Science-II, Allahabad Univ.)

Solution. $R_{100} = R_0(1 + 100 \alpha_0)$... (i)

$R_{40} = R_0(1 + 40 \alpha_0)$... (ii)

$\therefore \frac{3.767}{3.146} = \frac{1 + 100 \alpha_0}{1 + 40 \alpha_0}$ or $\alpha_0 = 0.00379$ or $1/264$ per $^\circ\text{C}$

From (i), we have $3.767 = R_0(1 + 100 \times 0.00379) \quad \therefore R_0 = 2.732 \Omega$

Now, $\alpha_{40} = \frac{\alpha_0}{1 + 40 \alpha_0} = \frac{0.00379}{1 + 40 \times 0.00379} = \frac{1}{304}$ per $^\circ\text{C}$

Example 1.13. A potential difference of 250 V is applied to a field winding at 15°C and the current is 5 A . What will be the mean temperature of the winding when current has fallen to 3.91 A , applied voltage being constant. Assume $\alpha_{15} = 1/254.5$. (Elect. Engg. Pune Univ.)

Solution. Let R_1 = winding resistance at 15°C ; R_2 = winding resistance at unknown mean temperature $t_2^\circ\text{C}$.

$\therefore R_1 = 250/5 = 50 \Omega$, $R_2 = 250/3.91 = 63.94 \Omega$

Now $R_2 = R_1 [1 + \alpha_{15}(t_2 - t_1)] \quad \therefore 63.94 = 50 \left[1 + \frac{1}{254.5}(t_2 - 15) \right]$

$\therefore t_2 = 86^\circ\text{C}$

Example 1.14. Two coils connected in series have resistances of $600\ \Omega$ and $300\ \Omega$ with temp. coeff. of 0.1% and 0.4% respectively at 20°C . Find the resistance of the combination at a temp. of 50°C . What is the effective temp. coeff. of combination ?

Solution. Resistance of $600\ \Omega$ resistor at 50°C is $= 600 [1 + 0.001 (50 - 20)] = 618\ \Omega$

Similarly, resistance of $300\ \Omega$ resistor at 50°C is $= 300 [1 + 0.004 (50 - 20)] = 336\ \Omega$

Hence, total resistance of combination at 50°C is $= 618 + 336 = 954\ \Omega$

Let β = resistance-temperature coefficient at 20°C

Now, combination resistance at $20^\circ\text{C} = 900\ \Omega$

Combination resistance at $50^\circ\text{C} = 954\ \Omega$

$$\therefore 954 = 900 [1 + \beta (50 - 20)] \quad \therefore \beta = 0.002$$

Example 1.15. Two wires A and B are connected in series at 0°C and resistance of B is 3.5 times that of A . The resistance temperature coefficient of A is 0.4% and that of the combination is 0.1% . Find the resistance temperature coefficient of B . (Elect. Technology, Hyderabad Univ.)

Solution. A simple technique which gives quick results in such questions is illustrated by the

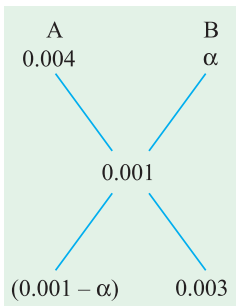

Fig. 1.9

diagram of Fig. 1.9. It is seen that $R_B/R_A = 0.003/(0.001 - \alpha)$

$$\text{or } 3.5 = 0.003/(0.001 - \alpha)$$

$$\text{or } \alpha = 0.000143^\circ\text{C}^{-1} \quad \text{or } 0.0143\%$$

Example 1.16. Two materials A and B have resistance temperature coefficients of 0.004 and 0.0004 respectively at a given temperature. In what proportion must A and B be joined in series to produce a circuit having a temperature coefficient of 0.001 ? (Elect. Technology, Indore Univ.)

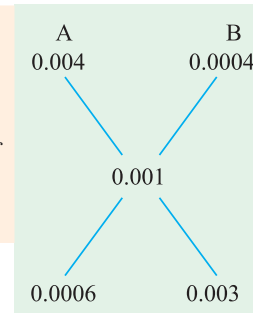

Fig. 1.10

Solution. Let R_A and R_B be the resistances of the two wires of materials A and B which are to be connected in series. Their ratio may be found by the simple technique shown in Fig. 1.10.

$$\frac{R_B}{R_A} = \frac{0.003}{0.0006} = 5$$

Hence, R_B must be 5 times R_A .

Example 1.17. A resistor of $80\ \Omega$ resistance, having a temperature coefficient of 0.0021 per degree C is to be constructed. Wires of two materials of suitable cross-sectional area are available. For material A , the resistance is $80\ \text{ohm per } 100\ \text{metres}$ and the temperature coefficient is 0.003 per degree C . For material B , the corresponding figures are $60\ \text{ohm per metre}$ and 0.0015 per degree C . Calculate suitable lengths of wires of materials A and B to be connected in series to construct the required resistor. All data are referred to the same temperature.

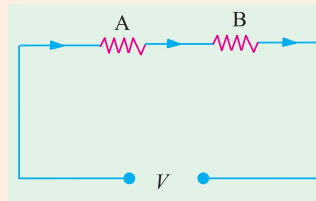

Solution. Let R_a and R_b be the resistances of suitable lengths of materials A and B respectively which when joined in series will have a combined temperature coeff. of 0.0021 . Hence, combination resistance at any given temperature is $(R_a + R_b)$. Suppose we heat these materials through $t^\circ\text{C}$.

When heated, resistance of A increases from R_a to $R_a (1 + 0.003 t)$. Similarly, resistance of B increases from R_b to $R_b (1 + 0.0015 t)$.

\therefore combination resistance after being heated through $t^\circ\text{C}$

$$= R_a (1 + 0.003 t) + R_b (1 + 0.0015 t)$$

The combination α being given, value of combination resistance can be also found directly as

$$\begin{aligned} &= (R_a + R_b) (1 + 0.0021 t) \\ \therefore (R_a + R_b) (1 + 0.0021 t) &= R_a (1 + 0.003 t) + R_b (1 + 0.0015 t) \end{aligned}$$

Simplifying the above, we get $\frac{R_b}{R_a} = \frac{3}{2}$...**(i)**

Now $R_a + R_b = 80 \Omega$...**(ii)**

Substituting the value of R_b from **(i)** into **(ii)** we get

$$R_a + \frac{3}{2} R_a = 80 \quad \text{or} \quad R_a = 32 \Omega \quad \text{and} \quad R_b = 48 \Omega$$

If L_a and L_b are the required lengths in metres, then

$$L_a = (100/80) \times 32 = \mathbf{40 \text{ m}} \quad \text{and} \quad L_b = (100/60) \times 48 = \mathbf{80 \text{ m}}$$

Example 1.18. A coil has a resistance of 18Ω when its mean temperature is 20°C and of 20Ω when its mean temperature is 50°C . Find its mean temperature rise when its resistance is 21Ω and the surrounding temperature is 15°C . **(Elect. Technology, Allahabad Univ.)**

Solution. Let R_0 be the resistance of the coil and α_0 its temp. coefficient at 0°C .

Then, $18 = R_0 (1 + \alpha_0 \times 20)$ and $20 = R_0 (1 + 50 \alpha_0)$

Dividing one by the other, we get

$$\frac{20}{18} = \frac{1 + 50 \alpha_0}{1 + 20 \alpha_0} \quad \therefore \alpha_0 = \frac{1}{250} \text{ per}^\circ\text{C}$$

If $t^\circ\text{C}$ is the temperature of the coil when its resistance is 21Ω then,

$$21 = R_0 (1 + t/250)$$

Dividing this equation by the above equation, we have

$$\frac{21}{18} = \frac{R_0 (1 + t/250)}{R_0 (1 + 20 \alpha_0)}; \quad t = 65^\circ\text{C}; \quad \text{temp. rise} = 65 - 15 = \mathbf{50^\circ\text{C}}$$

Example 1.19. The coil of a relay takes a current of 0.12 A when it is at the room temperature of 15°C and connected across a 60-V supply. If the minimum operating current of the relay is 0.1 A , calculate the temperature above which the relay will fail to operate when connected to the same supply. Resistance-temperature coefficient of the coil material is $0.0043 \text{ per}^\circ\text{C}$ at 6°C .

Solution. Resistance of the relay coil at 15°C is $R_{15} = 60/0.12 = 500 \Omega$

Let $t^\circ\text{C}$ be the temperature at which the minimum operating current of 0.1 A flows in the relay coil. Then, $R_t = 60/0.1 = 600 \Omega$

Now $R_{15} = R_0 (1 + 15 \alpha_0) = R_0 (1 + 15 \times 0.0043)$ and $R_t = R_0 (1 + 0.0043 t)$

$$\therefore \frac{R_t}{R_{15}} = \frac{1 + 0.0043 t}{1.0654} \quad \text{or} \quad \frac{600}{500} = \frac{1 + 0.0043 t}{1.0645} \quad \therefore t = \mathbf{65.4^\circ\text{C}}$$

If the temperature rises above this value, then due to increase in resistance, the relay coil will draw a current less than 0.1 A and, therefore, will fail to operate.

Example 1.20. Two conductors, one of copper and the other of iron, are connected in parallel and carry equal currents at 25°C . What proportion of current will pass through each if the temperature is raised to 100°C ? The temperature coefficients of resistance at 0°C are $0.0043/^\circ\text{C}$ and $0.0063/^\circ\text{C}$ for copper and iron respectively. **(Principles of Elect. Engg. Delhi Univ.)**

Solution. Since the copper and iron conductors carry equal currents at 25°C , their resistances are the same at that temperature. Let each be $R \text{ ohm}$.

For copper, $R_{100} = R_1 = R [1 + 0.0043 (100 - 25)] = 1.3225 R$

For iron, $R_{100} = R_2 = R [1 + 0.0063 (100 - 25)] = 1.4725 R$

If I is the current at 100°C , then as per current divider rule, current in the copper conductor is

$$I_1 = I \frac{R_2}{R_1 + R_2} = I \frac{1.4725 R}{1.3225 R + 1.4725 R} = 0.5268 I$$

$$I_2 = I \frac{R_1}{R_1 + R_2} = I \frac{1.3225 R}{2.795 R} = 0.4732 I$$

Hence, copper conductor will carry **52.68%** of the total current and iron conductor will carry the balance i.e. **47.32%**.

Example 1.21. The filament of a 240 V metal-filament lamp is to be constructed from a wire having a diameter of 0.02 mm and a resistivity at 20°C of 4.3 μΩ-cm. If α = 0.005/°C, what length of filament is necessary if the lamp is to dissipate 60 watts at a filament temp. of 2420°C?

Solution. Electric power generated = $I^2 R$ watts = V^2/R watts

$$\therefore V^2/R = 60 \quad \text{or} \quad 240^2/R = 60$$

$$\text{Resistance at } 2420^\circ\text{C} \quad R_{2420} = \frac{240 \times 240}{60} = 960 \, \Omega$$

$$\text{Now} \quad R_{2420} = R_{20} [1 + (2420 - 20) \times 0.005]$$

$$\text{or} \quad 960 = R_{20} (1 + 12)$$

$$\therefore R_{20} = 960/13 \, \Omega$$

$$\text{Now} \quad \rho_{20} = 4.3 \times 10^{-6} \, \Omega\text{-cm} \quad \text{and} \quad A = \frac{\pi(0.002)^2}{4} \text{ cm}^2$$

$$\therefore l = \frac{A \times R_{20}}{\rho_{20}} = \frac{\pi(0.002)^2 \times 960}{4 \times 13 \times 4.3 \times 10^{-6}} = 54 \text{ cm}$$

Example 1.22. A semi-circular ring of copper has an inner radius 6 cm, radial thickness 3 cm and an axial thickness 4 cm. Find the resistance of the ring at 50°C between its two end-faces. Assume specific resistance of Cu at 20°C = 1.724 × 10⁻⁶ ohm-cm and resistance temp. coeff. of Cu at 0°C = 0.0043/°C.

Solution. The semi-circular ring is shown in Fig. 1.11.

$$\text{Mean radius of ring} = (6 + 9)/2 = 7.5 \text{ cm}$$

$$\text{Mean length between end faces} = 7.5 \pi \text{ cm} = 23.56 \text{ cm}$$

$$\text{Cross-section of the ring} = 3 \times 4 = 12 \text{ cm}^2$$

$$\text{Now } \alpha_0 = 0.0043/^\circ\text{C}; \quad \alpha_{20} = \frac{0.0043}{1 + 20 \times 0.0043} = 0.00396$$

$$\rho_{50} = \rho_{20} [1 + \alpha_0 (50 - 20)] \\ = 1.724 \times 10^{-6} (1 + 30 \times 0.00396) = 1.93 \times 10^{-6} \, \Omega\text{-cm}$$

$$R_{50} = \frac{\rho_{50} \times l}{A} = \frac{1.93 \times 10^{-6} \times 23.56}{12} = 3.79 \times 10^{-6} \, \Omega$$

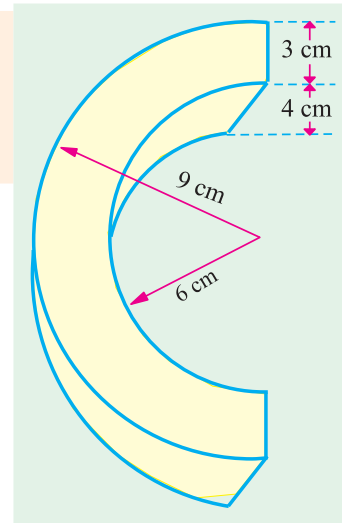

Fig.1.11

Tutorial Problems No. 1.2

1. It is found that the resistance of a coil of wire increases from 40 ohm at 15°C to 50 ohm at 60°C. Calculate the resistance temperature coefficient at 0°C of the conductor material.

[1/165 per °C] (Elect. Technology, Indore Univ.)

2. A tungsten lamp filament has a temperature of 2,050°C and a resistance of 500 Ω when taking normal working current. Calculate the resistance of the filament when it has a temperature of 25°C. Temperature coefficient at 0°C is 0.005/°C.

[50 Ω] (Elect. Technology, Indore Univ.)

3. An armature has a resistance of 0.2Ω at 150°C and the armature Cu loss is to be limited to 600 watts with a temperature rise of 55°C . If α_0 for Cu is $0.0043/^\circ\text{C}$, what is the maximum current that can be passed through the armature? **[50.8 A]**
4. A d.c. shunt motor after running for several hours on constant voltage mains of 400 V takes a field current of 1.6 A. If the temperature rise is known to be 40°C , what value of extra circuit resistance is required to adjust the field current to 1.6 A when starting from cold at 20°C ? Temperature coefficient = $0.0043/^\circ\text{C}$ at 20°C . **[36.69 Ω]**
5. In a test to determine the resistance of a single-core cable, an applied voltage of 2.5 V was necessary to produce a current of 2 A in it at 15°C .
 - (a) Calculate the cable resistance at 55°C if the temperature coefficient of resistance of copper at 0°C is $1/235$ per $^\circ\text{C}$.
 - (b) If the cable under working conditions carries a current of 10 A at this temperature, calculate the power dissipated in the cable. **[(a) 1.45 Ω (b) 145 W]**
6. An electric radiator is required to dissipate 1 kW when connected to a 230 V supply. If the coils of the radiator are of wire 0.5 mm in diameter having resistivity of $60 \mu\Omega\text{-cm}$, calculate the necessary length of the wire. **[1732 cm]**
7. An electric heating element to dissipate 450 watts on 250 V mains is to be made from nichrome ribbon of width 1 mm and thickness 0.05 mm. Calculate the length of the ribbon required (the resistivity of nichrome is $110 \times 10^{-8} \Omega\text{-m}$). **[631 m]**
8. When burning normally, the temperature of the filament in a 230 V, 150 W gas-filled tungsten lamp is $2,750^\circ\text{C}$. Assuming a room temperature of 16°C , calculate (a) the normal current taken by the lamp (b) the current taken at the moment of switching on. Temperature coefficient of tungsten is $0.0047 \Omega/\Omega^\circ\text{C}$ at 0°C . **[(a) 0.652 A (b) 8.45 A] (Elect. Engg. Madras Univ.)**
9. An aluminium wire 5 m long and 2 mm diameter is connected in parallel with a wire 3 m long. The total current is 4 A and that in the aluminium wire is 2.5 A. Find the diameter of the copper wire. The respective resistivities of copper and aluminium are 1.7 and $2.6 \mu\Omega\text{-m}$. **[0.97 mm]**
10. The field winding of d.c. motor connected across 230 V supply takes 1.15 A at room temp. of 20°C . After working for some hours the current falls to 0.26 A, the supply voltage remaining constant. Calculate the final working temperature of field winding. Resistance temperature coefficient of copper at 20°C is $1/254.5$. **[70.4 $^\circ\text{C}$] (Elect. Engg. Pune Univ.)**
11. It is required to construct a resistance of 100Ω having a temperature coefficient of 0.001 per $^\circ\text{C}$. Wires of two materials of suitable cross-sectional area are available. For material A, the resistance is 97Ω per 100 metres and for material B, the resistance is 40Ω per 100 metres. The temperature coefficient of resistance for material A is 0.003 per $^\circ\text{C}$ and for material B is 0.0005 per $^\circ\text{C}$. Determine suitable lengths of wires of materials A and B. **[A : 19.4 m, B : 200 m]**
12. The resistance of the shunt winding of a d.c. machine is measured before and after a run of several hours. The average values are 55 ohms and 63 ohms. Calculate the rise in temperature of the winding. (Temperature coefficient of resistance of copper is 0.00428 ohm per ohm per $^\circ\text{C}$). **[36 $^\circ\text{C}$] (London Univ.)**
13. A piece of resistance wire, 15.6 m long and of cross-sectional area 12 mm^2 at a temperature of 0°C , passes a current of 7.9 A when connected to d.c. supply at 240 V. Calculate (a) resistivity of the wire (b) the current which will flow when the temperature rises to 55°C . The temperature coefficient of the resistance wire is $0.00029 \Omega/\Omega/^\circ\text{C}$. **[(a) 23.37 $\mu\Omega\text{-m}$ (b) 7.78 A] (London Univ.)**
14. A coil is connected to a constant d.c. supply of 100 V. At start, when it was at the room temperature of 25°C , it drew a current of 13 A. After sometime, its temperature was 70°C and the current reduced to 8.5 A. Find the current it will draw when its temperature increases further to 80°C . Also, find the temperature coefficient of resistance of the coil material at 25°C . **[7.9 A; $0.01176^\circ\text{C}^{-1}$] (F.Y. Engg. Univ.)**
15. The resistance of the filed coils with copper conductors of a dynamo is 120Ω at 25°C . After working for 6 hours on full load, the resistance of the coil increases to 140Ω . Calculate the mean temperature rise of the field coil. Take the temperature coefficient of the conductor material as 0.0042 at 0°C . **[43.8 $^\circ\text{C}$] (Elements of Elec. Engg. Banglore Univ.)**

1.13. Ohm's Law

This law applies to electric to electric conduction through good conductors and may be stated as follows :

The ratio of potential difference (V) between any two points on a conductor to the current (I) flowing between them, is constant, provided the temperature of the conductor does not change.

In other words, $\frac{V}{I} = \text{constant}$ or $\frac{V}{I} = R$

where R is the resistance of the conductor between the two points considered.

Put in another way, it simply means that provided R is kept constant, current is directly proportional to the potential difference across the ends of a conductor. However, this linear relationship between V and I does not apply to all non-metallic conductors. For example, for silicon carbide, the relationship is given by $V = KI^m$ where K and m are constants and m is less than unity. It also does not apply to non-linear devices such as Zener diodes and voltage-regulator (VR) tubes.

Example 1.23. A coil of copper wire has resistance of 90Ω at 20°C and is connected to a 230-V supply. By how much must the voltage be increased in order to maintain the current constant if the temperature of the coil rises to 60°C ? Take the temperature coefficient of resistance of copper as 0.00428 from 0°C .

Solution. As seen from Art. 1.10

$$\frac{R_{60}}{R_{20}} = \frac{1 + 60 \times 0.00428}{1 + 20 \times 0.00428} \quad \therefore R_{60} = 90 \times 1.2568/1.0856 = 104.2 \Omega$$

Now, current at $20^\circ\text{C} = 230/90 = 23/9 \text{ A}$

Since the wire resistance has become 104.2Ω at 60°C , the new voltage required for keeping the current constant at its previous value $= 104.2 \times 23/9 = 266.3 \text{ V}$

\therefore increase in voltage required $= 266.3 - 230 = 36.3 \text{ V}$

Example 1.24. Three resistors are connected in series across a 12-V battery. The first resistor has a value of 1Ω , second has a voltage drop of 4 V and the third has a power dissipation of 12 W . Calculate the value of the circuit current.

Solution. Let the two unknown resistors be R_2 and R_3 and I the circuit current

$$\therefore I^2 R_3 = 12 \quad \text{and} \quad IR_3 = 4 \quad \therefore R_3 = \frac{3}{4} R_2^2. \quad \text{Also, } I = \frac{4}{R_2}$$

Now, $I(1 + R_2 + R_3) = 12$

Substituting the values of I and R_3 , we get

$$\frac{4}{R_2} \left(1 + R_2 + \frac{3}{4} R_2^2 \right) = 12 \quad \text{or} \quad 3R_2^2 - 8R_2 + 4 = 0$$

$$\therefore R_2 = \frac{8 \pm \sqrt{64 - 48}}{6} \quad \therefore R_2 = 2 \Omega \quad \text{or} \quad \frac{2}{3} \Omega$$

$$\therefore R_3 = \frac{3}{4} R_2^2 = \frac{3}{4} \times 2^2 = 3 \Omega \quad \text{or} \quad \frac{3}{4} \left(\frac{2}{3} \right)^2 = \frac{1}{3} \Omega$$

$$\therefore I = \frac{12}{1 + 2 + 3} = 2 \text{ A} \quad \text{or} \quad I = \frac{12}{1 + (2/3) + (1/3)} = 6 \text{ A}$$

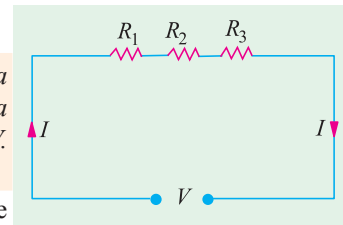

1.14. Resistance in Series

When some conductors having resistances R_1 , R_2 and R_3 etc. are joined end-on-end as in Fig. 1.12, they are said to be connected in series. It can be proved that the equivalent resistance or total resistance between points A and D is equal to the sum of the three individual resistances. Being a series circuit, it should be remembered that (i) current is the same through all the three conductors

(ii) but voltage drop across each is different due to its different resistance and is given by Ohm's Law and (iii) sum of the three voltage drops is equal to the voltage applied across the three conductors. There is a progressive fall in potential as we go from point A to D as shown in Fig. 1.13.

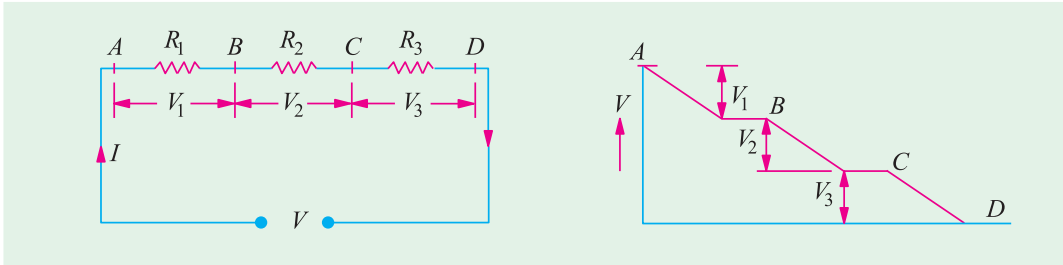

Fig. 1.12

Fig. 1.13

∴ $V = V_1 + V_2 + V_3 = IR_1 + IR_2 + IR_3$ —Ohm's Law

But $V = IR$

where R is the equivalent resistance of the series combination.

∴ $IR = IR_1 + IR_2 + IR_3$ or $R = R_1 + R_2 + R_3$

Also $\frac{1}{G} = \frac{1}{G_1} + \frac{1}{G_2} + \frac{1}{G_3}$

As seen from above, the main characteristics of a series circuit are :

1. same current flows through all parts of the circuit.
2. different resistors have their individual voltage drops.
3. voltage drops are additive.
4. applied voltage equals the sum of different voltage drops.
5. resistances are additive.
6. powers are additive.

1.15. Voltage Divider Rule

Since in a series circuit, same current flows through each of the given resistors, voltage drop varies directly with its resistance. In Fig. 1.14 is shown a 24-V battery connected across a series combination of three resistors.

Total resistance $R = R_1 + R_2 + R_3 = 12 \Omega$

According to Voltage Divider Rule, various voltage drops are :

$$V_1 = V \cdot \frac{R_1}{R} = 24 \times \frac{2}{12} = 4 \text{ V}$$

$$V_2 = V \cdot \frac{R_2}{R} = 24 \times \frac{4}{12} = 8 \text{ V}$$

$$V_3 = V \cdot \frac{R_3}{R} = 24 \times \frac{6}{12} = 12 \text{ V}$$

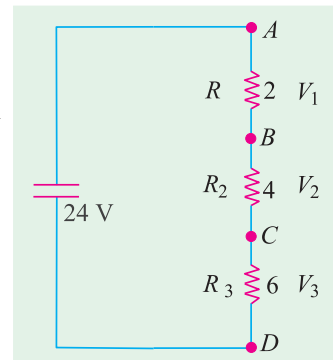

Fig.1.14

1.16. Resistances in Parallel

Three resistances, as joined in Fig. 1.15 are said to be connected in parallel. In this case (i) p.d. across all resistances is the same (ii) current in each resistor is different and is given by Ohm's Law and (iii) the total current is the sum of the three separate currents.

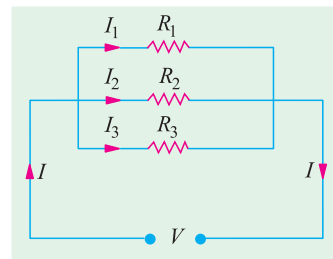

Fig.1.15

$$I = I_1 + I_2 + I_3 = \frac{V}{R_1} + \frac{V}{R_2} + \frac{V}{R_3}$$

Now,

$$I = \frac{V}{R} \text{ where } V \text{ is the applied voltage.}$$

R = equivalent resistance of the parallel combination.

∴

$$\frac{V}{R} = \frac{V}{R_1} + \frac{V}{R_2} + \frac{V}{R_3} \quad \text{or} \quad \frac{1}{R} = \frac{1}{R_1} + \frac{1}{R_2} + \frac{1}{R_3}$$

Also

$$G = G_1 + G_2 + G_3$$

The main characteristics of a parallel circuit are :

1. same voltage acts across all parts of the circuit
2. different resistors have their individual current.
3. branch currents are additive.
4. conductances are additive.
5. powers are additive.

Example 1.25. What is the value of the unknown resistor R in Fig. 1.16 if the voltage drop across the 500Ω resistor is 2.5 volts? All resistances are in ohm. (Elect. Technology, Indore Univ.)

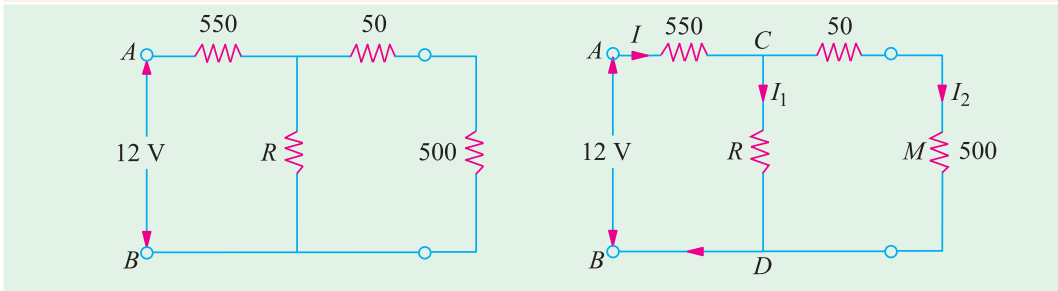

Fig. 1.16

Solution. By direct proportion, drop on 50Ω resistance = $2.5 \times 50/500 = 0.25 \text{ V}$

$$\text{Drop across CMD or CD} = 2.5 + 0.25 = 2.75 \text{ V}$$

$$\text{Drop across } 550 \Omega \text{ resistance} = 12 - 2.75 = 9.25 \text{ V}$$

$$I = 9.25/550 = 0.0168 \text{ A}, I_2 = 2.5/500 = 0.005 \text{ A}$$

$$I_1 = 0.0168 - 0.005 = 0.0118 \text{ A}$$

∴

$$0.0118 = 2.75/R; \quad R = 233 \Omega$$

Example 1.26. Calculate the effective resistance of the following combination of resistances and the voltage drop across each resistance when a P.D. of 60 V is applied between points A and B.

Solution. Resistance between A and C (Fig. 1.17).

$$= 6 \parallel 3 = 2 \Omega$$

$$\text{Resistance of branch ACD} = 18 + 2 = 20 \Omega$$

Now, there are two parallel paths between points A and D of resistances 20Ω and 5Ω

$$\text{Hence, resistance between A and D} = 20 \parallel 5 = 4 \Omega$$

$$\therefore \text{Resistance between A and B} = 4 + 8 = 12 \Omega$$

$$\text{Total circuit current} = 60/12 = 5 \text{ A}$$

$$\text{Current through } 5 \Omega \text{ resistance} = 5 \times \frac{20}{25} = 4 \text{ A}$$

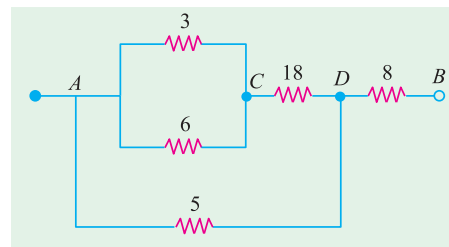

Fig. 1.17

—Art. 1.25

Current in branch $ACD = 5 \times \frac{5}{25} = 1 \text{ A}$
 \therefore P.D. across 3Ω and 6Ω resistors $= 1 \times 2 = 2 \text{ V}$
 P.D. across 18Ω resistors $= 1 \times 18 = 18 \text{ V}$
 P.D. across 5Ω resistors $= 4 \times 5 = 20 \text{ V}$
 P.D. across 8Ω resistors $= 5 \times 8 = 40 \text{ V}$

Example 1.27. A circuit consists of four 100-W lamps connected in parallel across a 230-V supply. Inadvertently, a voltmeter has been connected in series with the lamps. The resistance of the voltmeter is 1500Ω and that of the lamps under the conditions stated is six times their value then burning normally. What will be the reading of the voltmeter?

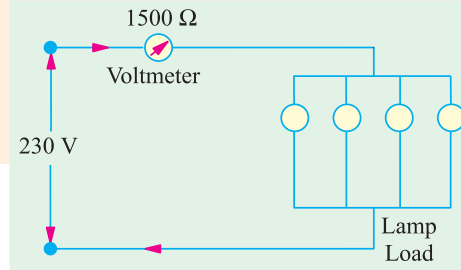

Fig.1.18

Solution. The circuit is shown in Fig. 1.18. The wattage of a lamp is given by :

$$W = I^2 R = V^2/R$$

$$\therefore 100 = 230^2/R \quad \therefore R = 529 \Omega$$

Resistance of each lamp under stated condition is $= 6 \times 529 = 3174 \Omega$

Equivalent resistance of these four lamps connected in parallel $= 3174/4 = 793.5 \Omega$

This resistance is connected in series with the voltmeter of 1500Ω resistance.

$$\therefore \text{total circuit resistance} = 1500 + 793.5 = 2293.5 \Omega$$

$$\therefore \text{circuit current} = 230/2293.5 \text{ A}$$

According to Ohm's law, voltage drop across the voltmeter $= 1500 \times 230/2293.5 = 150 \text{ V (approx)}$

Example 1.28. Determine the value of R and current through it in Fig. 1.19, if current through branch AO is zero. (Elect. Engg. & Electronics, Bangalore Univ.)

Solution. The given circuit can be redrawn as shown in Fig. 1.19 (b). As seen, it is nothing else but Wheatstone bridge circuit. As is well-known, when current through branch AO becomes zero, the bridge is said to be balanced. In that case, products of the resistances of opposite arms of the bridge become equal.

$$\therefore 4 \times 1.5 = R \times 1; R = 6 \Omega$$

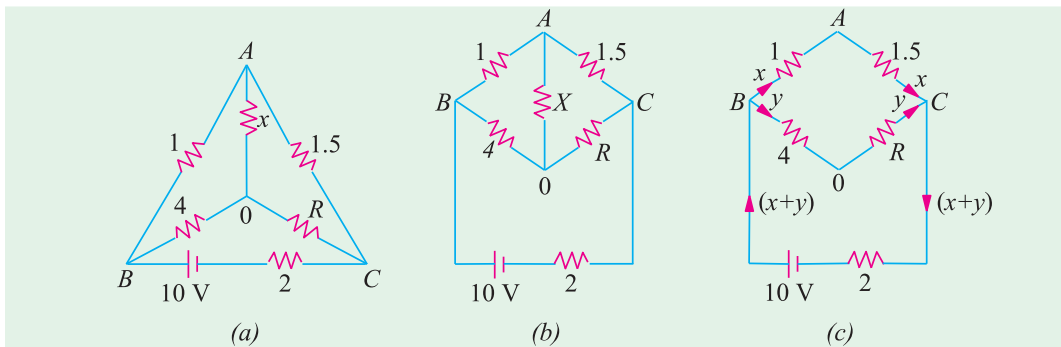

Fig.1.19

Under condition of balance, it makes no difference if resistance X is removed thereby giving us the circuit of Fig. 1.19 (c). Now, there are two parallel paths between points B and C of resistances $(1 + 1.5) = 2.5 \Omega$ and $(4 + 6) = 10 \Omega$. $R_{BC} = 10 \parallel 2.5 = 2 \Omega$

Total circuit resistance $= 2 + 2 = 4 \Omega$. Total circuit current $= 10/4 = 2.5 \text{ A}$

This current gets divided into two parts at point B . Current through R is

$$y = 2.5 \times 2.5/12.5 = 0.5 \text{ A}$$

Example 1.29. In the unbalanced bridge circuit of Fig. 1.20 (a), find the potential difference that exists across the open switch S . Also, find the current which will flow through the switch when it is closed.

Solution. With switch open, there are two parallel branches across the 15-V supply. Branch ABC has a resistance of $(3 + 12) = 15 \Omega$ and branch ADC has a resistance of $(6 + 4) = 10 \Omega$. Obviously, each branch has 15 V applied across it.

$$V_B = 12 \times 15/15 = 12 \text{ V}; V_D = 4 \times 15/(6 + 4) = 6 \text{ V}$$

$$\therefore \text{p.d. across points } B \text{ and } D = V_B - V_D = 12 - 6 = 6 \text{ V}$$

When S is closed, the circuit becomes as shown in Fig. 1.20 (b) where points B and D become electrically connected together.

$$R_{AB} = 3 \parallel 6 = 2 \Omega \quad \text{and} \quad R_{BC} = 4 \parallel 12 = 3 \Omega$$

$$R_{AC} = 2 + 3 = 5 \Omega \quad ; \quad I = 15/5 = 3 \text{ A}$$

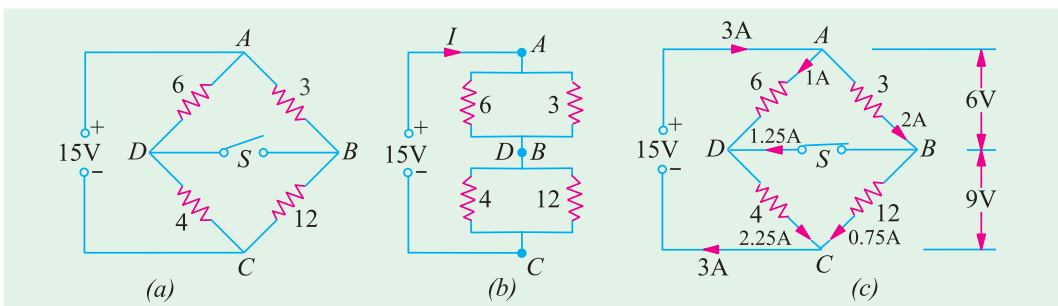

Fig. 1.20

Current through arm $AB = 3 \times 6/9 = 2 \text{ A}$. The voltage drop over arm $AB = 3 \times 2 = 6 \text{ V}$. Hence, drop over arm $BC = 15 - 6 = 9 \text{ V}$. Current through $BC = 9/12 = 0.75 \text{ A}$. It is obvious that at point B , the incoming current is 2 A, out of which 0.75 A flows along BC , whereas remaining $2 - 0.75 = 1.25 \text{ A}$ passes through the switch.

As a check, it may be noted that current through $AD = 6/6 = 1 \text{ A}$. At point D , this current is joined by 1.25 A coming through the switch. Hence, current through $DC = 1.25 + 1 = 2.25 \text{ A}$. This fact can be further verified by the fact that there is a voltage drop of 9 V across 4 Ω resistor thereby giving a current of $9/4 = 2.25 \text{ A}$.

Example 1.30. A 50-ohm resistor is in parallel with 100-ohm resistor. Current in 50-ohm resistor is 7.2 A. How will you add a third resistor and what will be its value if the line-current is to be 12.1 amp?

[Nagpur Univ., Nov. 1997]

Solution. Source voltage = $50 \times 7.2 = 360 \text{ V}$, Current through 100-ohm resistor = 3.6 A

Total current through these two resistors in parallel = 10.8 A

For the total line current to be 12.1 A, third resistor must be connected in parallel, as the third branch, for carrying $(12.1 - 10.8) = 1.3 \text{ A}$. If R is this resistor $R = 360/1.3 = 277 \text{ ohms}$

Example 1.31. In the circuit shown in Fig. 1.21, calculate the value of the unknown resistance R and the current flowing through it when the current in branch OC is zero.

[Nagpur Univ., April 1996]

Solution. If current through R -ohm resistor is I amp, AO branch carries the same current, since, current through the branch CO is zero. This also means that the nodes C and O are at the equal potential. Then, equating voltage-drops, we have $V_{AO} = V_{AC}$.

This means branch AC carries a current of $4I$.

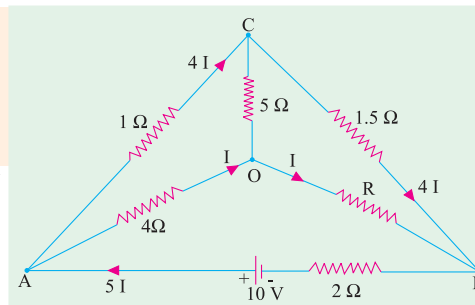

Fig. 1.21

This is current of $4I$ also flows through the branch CB . Equating the voltage-drops in branches OB and CB ,

$$1.5 \times 4I = RI, \text{ giving } R = 6 \Omega$$

At node A , applying KCL , a current of $5I$ flows through the branch BA from B to A . Applying KVL around the loop $BAOB$, $I = 0.5$ Amp.

Example 1.32. Find the values of R and V_s in Fig. 1.22. Also find the power supplied by the source. [Nagpur University, April 1998]

Solution. Name the nodes as marked on Fig. 1.22. Treat node A as the reference node, so that $V_A = 0$. Since path ADC carries 1 A with a total of 4 ohms resistance, $V_C = +4$ V.

Since $V_{CA} + 4$, $I_{CA} = 4/8 = 0.5$ amp from C to A . Applying KCL at node C , $I_{BC} = 1.5$ A from B to C . Along the path BA , 1 A flows through 7 -ohm resistor.

$$V_B = +7 \text{ Volts. } V_{BC} = 7 - 4 = +3.$$

This drives a current of 1.5 amp, through R ohms. Thus $R = 3/1.5 = 2$ ohms.

Applying KCL at node B , $I_{FB} = 2.5$ A from F to B .

$V_{FB} = 2 \times 2.5 = 5$ volts, F being higher than B from the view-point of Potential. Since V_B has already been evaluated as $+7$ volts, $V = 12$ volts (w.r. to A). Thus, the source voltage $V_s = 12$ volts.

Example 1.33. In Fig. 1.23 (a), if all the resistances are of 6 ohms, calculate the equivalent resistance between any two diagonal points. [Nagpur Univ. April 1998]

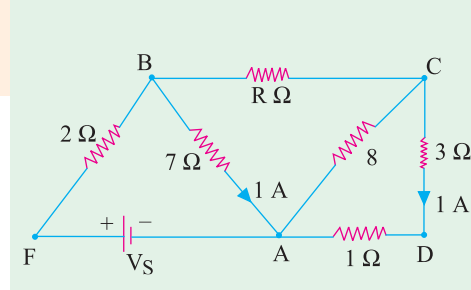

Fig. 1.22

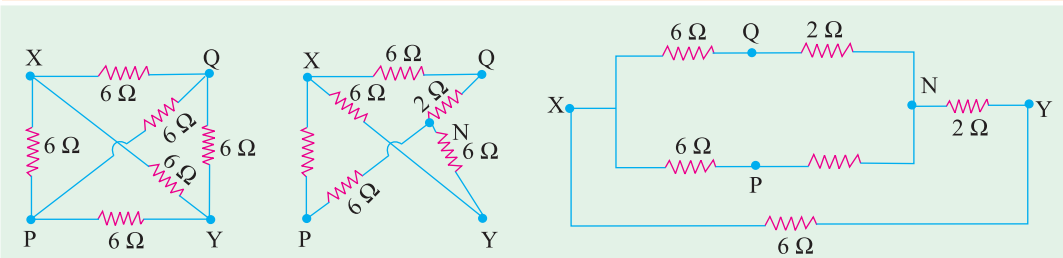

Fig. 1.23 (a)

Fig. 1.23 (b)

Fig. 1.23 (c)

Solution. If X - Y are treated as the concerned diagonal points, for evaluating equivalent resistance offered by the circuit, there are two ways of transforming this circuit, as discussed below :

Method 1 : Delta to Star conversion applicable to the delta of PQY introducing an additional node N as the star-point. Delta with 6 ohms at each side is converted as 2 ohms as each leg of the star-equivalent. This is shown in Fig. 1.23 (b), which is further simplified in Fig. 1.23 (c). After handling series-parallel combinations of resistances,

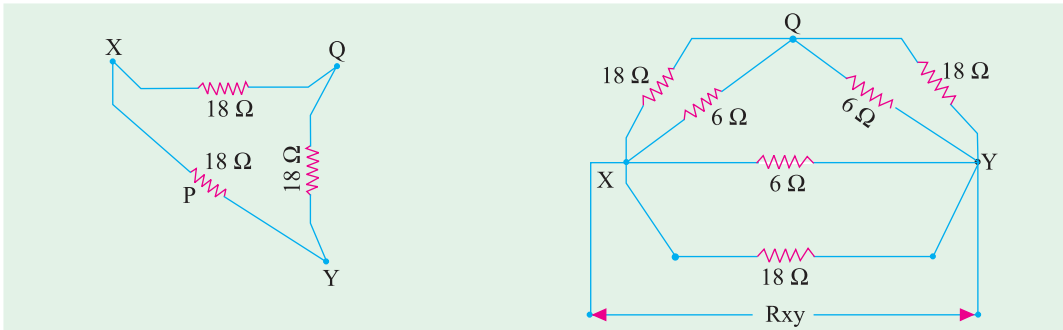

Fig. 1.23 (d)

Fig. 1.23 (e)

Total resistance between X and Y terminals in Fig. 1.23 (c) comes out to be 3 ohms.

Method 2 : Star to Delta conversion with P as the star-point and XYQ to be the three points of concerned converted delta. With star-elements of 6 ohms each, equivalent delta-elements will be 18 ohms, as Fig. 1.23 (d). This is included while redrawing the circuit as in Fig. 1.23 (e).

After simplifying, the series-parallel combination results into the final answer as $R_{XY} = 3$ ohms.

Example 1.34. For the given circuit find the current I_A and I_B . [Bombay Univ. 1991]

Solution. Nodes A, B, C, D and reference node 0 are marked on the same diagram.

I_A and I_B are to be found.

Apply KCL at node A . From C to A , current = $7 + I_B$

At node 0, KCL is applied, which gives a current of $7 + I_A$ through the 7 volt voltage source. Applying KCL at node B gives a current $I_A - I_B$ through 2-ohm resistor in branch CB . Finally, at node A , KCL is applied. This gives a current of $7 + I_B$ through 1-ohm resistor in branch CA .

Around the Loop $OCBO$, $2(I_A - I_B) + 1 \cdot I_A = 7$

Around the Loop $CABC$, $1(7 + I_B) + 3I_B - 2(I_A - I_B) = 0$

After rearranging the terms, $3I_A - 2I_B = 7$, $2I_A + 6I_B = -7$

This gives $I_A = 2$ amp, $I_B = -0.5$ amp.

This means that I_B is 0.5 amp from B to A .

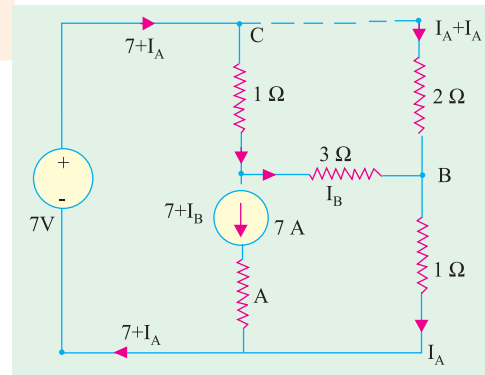

Fig. 1.24

Example 1.35. Find R_{AB} in the circuit, given in Fig. 1.25. [Bombay Univ. 2001]

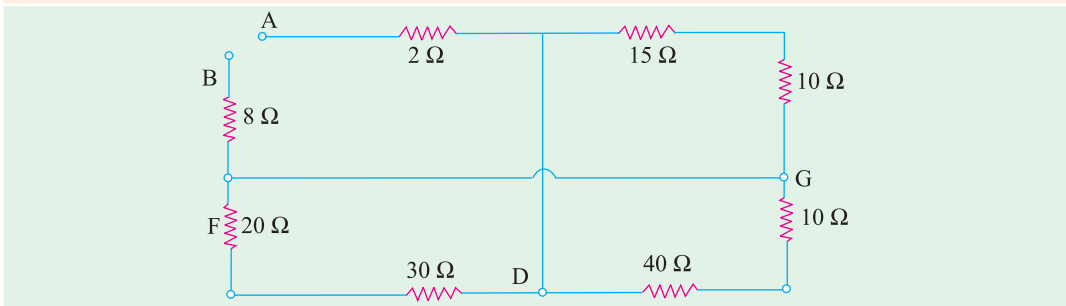

Fig. 1.25 (a)

Solution. Mark additional nodes on the diagram, C, D, F, G , as shown. Redraw the figure as in 1.25 (b), and simplify the circuit, to evaluate R_{AB} , which comes out to be 22.5 ohms.

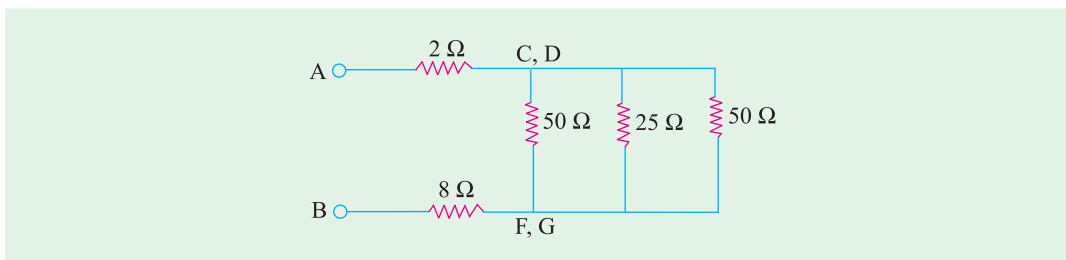

Fig. 1.25 (b)

Example 1.36. Find current through 4 resistance.

[Bombay Univ. 2001]

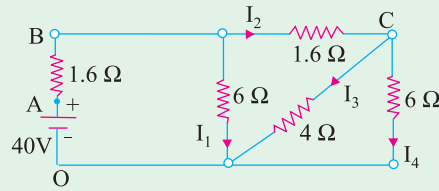

Fig. 1.26

Solution. Simplifying the series-parallel combinations, and solving the circuit, the source current is 10 amp. With respect to 0, $V_A = 40$, $V_B = 40 - 16 = 24$ volts.

$$I_1 = 4 \text{ amp, hence } I_2 = 6 \text{ amp}$$

$$V_C = V_B - I_2 \times 1.6 = 24 - 9.6 = 14.4 \text{ volts}$$

$$I_3 = 14.4/4 = 3.6 \text{ amp, which is the required answer. Further } I_4 = 24 \text{ amp.}$$

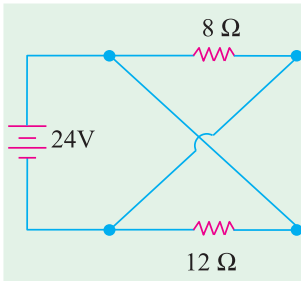

Fig. 1.27

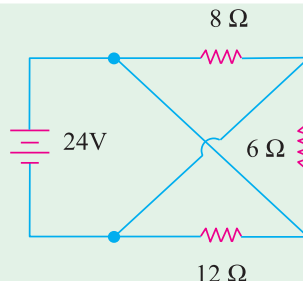

Fig. 1.28

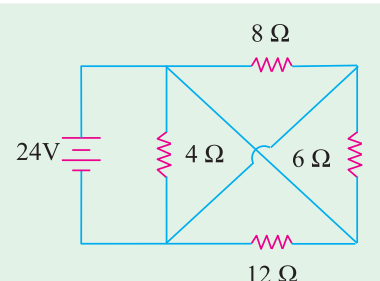

Fig. 1.29

Tutorial Problems No. 1.3

- Find the current supplied by the battery in the circuit of Fig. 1.27. [5 A]
- Compute total circuit resistance and battery current in Fig. 1.28. [8/3 Ω, 9 A]
- Calculate battery current and equivalent resistance of the network shown in Fig. 1.29. [15 A; 8/5 Ω]
- Find the equivalent resistance of the network of Fig. 1.30 between terminals A and B. All resistance values are in ohms. [6 Ω]
- What is the equivalent resistance of the circuit of Fig. 1.31 between terminals A and B? All resistances are in ohms. [4 Ω]
- Compute the value of battery current I in Fig. 1.32. All resistances are in ohm. [6 A]

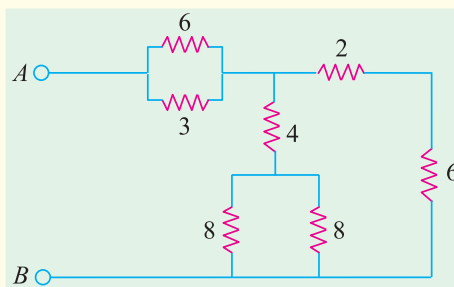

Fig. 1.30

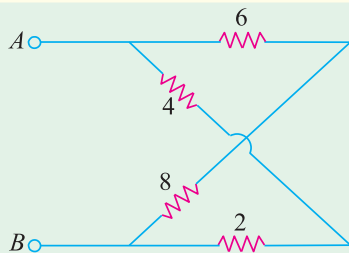

Fig. 1.31

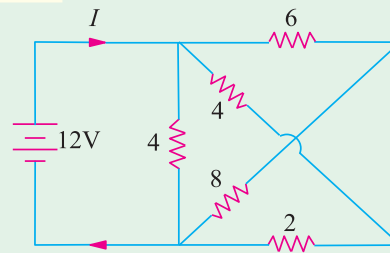

Fig. 1.32

7. Calculate the value of current I supplied by the voltage source in Fig. 1.33. All resistance values are in ohms. **(Hint : Voltage across each resistor is 6 V) [1 A]**
8. Compute the equivalent resistance of the circuit of Fig. 1.34 between points (i) ab (ii) ac and (iii) bc . All resistances values are in ohm. **[(i) 6 Ω (ii) 4.5 Ω (iii) 4.5 Ω]**

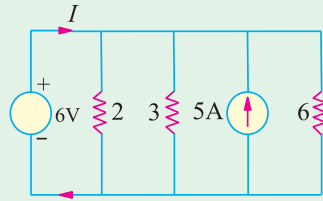

Fig. 1.33

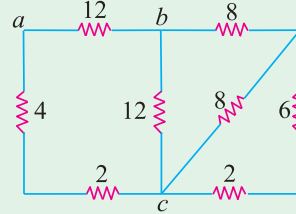

Fig. 1.34

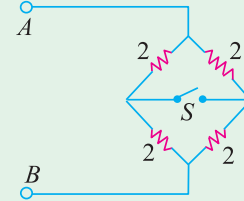

Fig. 1.35

9. In the circuit of Fig. 1.35, find the resistance between terminals A and B when switch is (a) open and (b) closed. Why are the two values equal ? **[(a) 2 Ω (b) 2 Ω]**
10. The total current drawn by a circuit consisting of three resistors connected in parallel is 12 A. The voltage drop across the first resistor is 12 V, the value of second resistor is 3 Ω and the power dissipation of the third resistor is 24 W. What are the resistances of the first and third resistors ? **[2 Ω ; 6 Ω]**
11. Three parallel connected resistors when connected across a d.c. voltage source dissipate a total power of 72 W. The total current drawn is 6 A, the current flowing through the first resistor is 3 A and the second and third resistors have equal value. What are the resistances of the three resistors ? **[4 Ω ; 8 Ω ; 8 Ω]**
12. A bulb rated 110 V, 60 watts is connected with another bulb rated 110-V, 100 W across a 220 V mains. Calculate the resistance which should be joined in parallel with the first bulb so that both the bulbs may take their rated power. **[302.5 Ω]**
13. Two coils connected in parallel across 100 V supply mains take 10 A from the line. The power dissipated in one coil is 600 W. What is the resistance of the other coil ? **[25 Ω]**
14. An electric lamp whose resistance, when in use, is 2 Ω is connected to the terminals of a dry cell whose e.m.f. is 1.5 V. If the current through the lamp is 0.5 A, calculate the internal resistance of the cell and the potential difference between the terminals of the lamp. If two such cells are connected in parallel, find the resistance which must be connected in series with the arrangement to keep the current the same as before. **[1 Ω ; 1 V ; 0.5 Ω] (Elect. Technology, Indore Univ.)**
15. Determine the current by the source in the circuit shown below. **(Bombay Univ. 2001)**

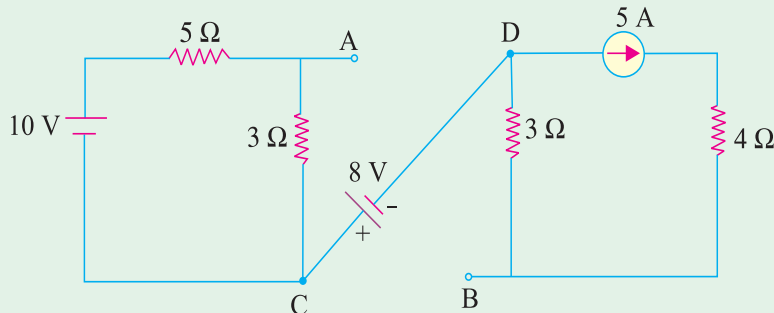

Fig. 1.36. (a)

Hint. Series-parallel combinations of resistors have to be dealt with. This leads to the source current of 28.463 amp.

16. Find the voltage of point A with respect to point B in the Fig. 1.36 (b). Is it positive with respect to B ?
(Bombay University, 2000)

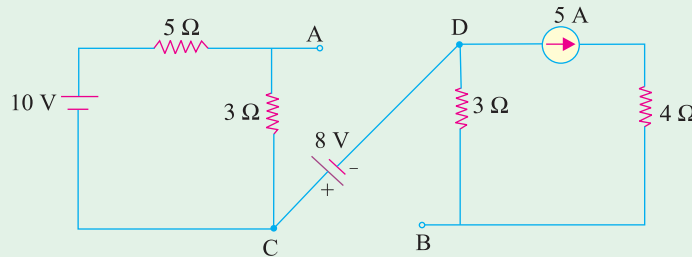

Fig. 1.36 (b)

Hint. If $V_A = 0$, $V_C = -1.25 \times 3 = -3.75$ V
 $V_D = -3.75 - 8 = -11.75$ V
 $V_B = V_D + 15 = +3.25$ volts
 Thus, the potential of point A with respect to B is -3.25 V.

1.17. Types of Resistors

(a) Carbon Composition

It is a combination of carbon particles and a binding resin with different proportions for providing desired resistance. Attached to the ends of the resistive element are metal caps which have axial leads of tinned copper wire for soldering the resistor into a circuit. The resistor is enclosed in a plastic case to prevent the entry of moisture and other harmful elements from outside. Billions of carbon composition resistors are used in the electronic industry every year. They are available in power ratings of 1/8, 1/4, 1/2, 1 and 2 W, in voltage ratings of 250, 350 and 500 V. They have low failure rates when properly used.

Such resistors have a tendency to produce electric noise due to the current passing from one carbon particle to another. This noise appears in the form of a hiss in a loudspeaker connected to a hi-fi system and can overcome very weak signals. That is why carbon composition resistors are used where performance requirements are not demanding and where low cost is the main consideration. Hence, they are extensively used in entertainment electronics although better resistors are used in critical circuits.

(b) Deposited Carbon

Deposited carbon resistors consist of ceramic rods which have a carbon film deposited on them. They are made by placing a ceramic rod in a methane-filled flask and heating it until, by a gas-cracking process, a carbon film is deposited on them. A helix-grinding process forms the resistive path. As compared to carbon composition resistors, these resistors offer a major improvement in lower current noise and in closer tolerance. These resistors are being replaced by metal film and metal glaze resistors.

(c) High-Voltage Ink Film

These resistors consist of a ceramic base on which a special resistive ink is laid down in a helical band. These resistors are capable of withstanding high voltages and find extensive use in cathode-ray circuits, in radar and in medical electronics. Their resistances range from 1 k Ω to 100,000 M Ω with voltage range up to 1000 kV.

(d) Metal Film

Metal film resistors are made by depositing vaporized metal in vacuum on a ceramic-core rod. The resistive path is helix-ground as in the case of deposited carbon resistors. Metal film resistors have excellent tolerance and temperature coefficient and are extremely reliable. Hence, they are very suitable for numerous high grade applications as in low-level stages of certain instruments although they are much more costlier.

(e) Metal Glaze

A metal glaze resistor consists of a metal glass mixture which is applied as a thick film to a ceramic substrate and then fired to form a film. The value of resistance depends on the amount of metal in the mixture. With helix-grinding, the resistance can be made to vary from $1\ \Omega$ to many mega-ohms.

Another category of metal glaze resistors consists of a tinned oxide film on a glass substrate.

(f) Wire-wound

Wire-wound resistors are different from all other types in the sense that no film or resistive coating is used in their construction. They consist of a ceramic-core wound with a drawn wire having accurately-controlled characteristics. Different wire alloys are used for providing different resistance ranges. These resistors have highest stability and highest power rating.

Because of their bulk, high-power ratings and high cost, they are not suitable for low-cost or high-density, limited-space applications. The completed wire-wound resistor is coated with an insulating material such as baked enamel.

(g) Cermet (Ceramic Metal)

The cermet resistors are made by firing certain metals blended with ceramics on a ceramic substrate. The value of resistance depends on the type of mix and its thickness. These resistors have very accurate resistance values and show high stability even under extreme temperatures. Usually, they are produced as small rectangles having leads for being attached to printed circuit boards (PCB).

1.18. Nonlinear Resistors

Those elements whose $V-I$ curves are not straight lines are called nonlinear elements because their resistances are nonlinear resistances. Their $V-I$ characteristics can be represented by a suitable equation.

Examples of nonlinear elements are filaments of incandescent lamps, diodes, thermistors and varistors. A varistor is a special resistor made of carborundum crystals held together by a binder. Fig. 1.37 (a) shows how current through a varistor increase rapidly when the applied voltage increases beyond a certain amount (nearly 100 V in the present case).

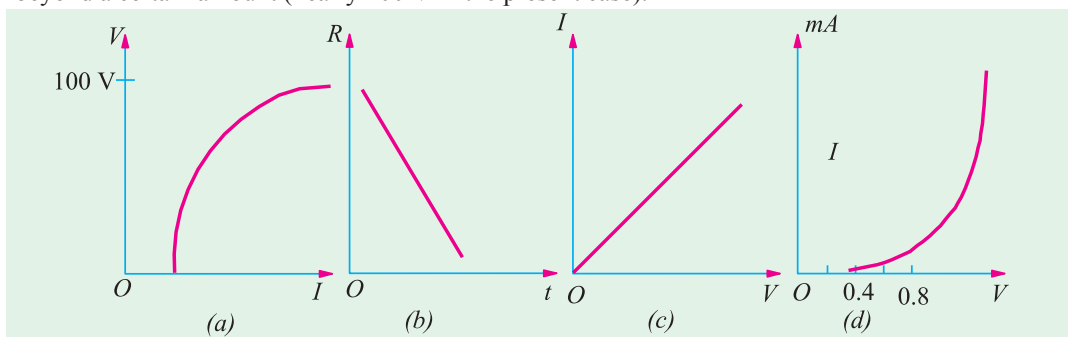

Fig. 1.37

There is a corresponding rapid decrease in resistance when the current increases. Hence, varistors are generally used to provide over-voltage protection in certain circuits.

A thermistor is made of metallic oxides in a suitable binder and has a large negative coefficient of resistance *i.e.*, its resistance decreases with increase in temperature as shown in Fig. 1.30 (b). Fig. 1.30 (c) shows how the resistance of an incandescent lamp increases with voltage whereas Fig. 1.30 (d) shows the $V-I$ characteristics of a typical silicon diode. For a germanium diode, current is related to its voltage by the relation.

$$I = I_o (e^{V/0.026} - 1)$$

1.19. Varistor (Nonlinear Resistor)

It is a voltage-dependent metal-oxide material whose resistance decreases sharply with increasing voltage. The relationship between the current flowing through a varistor and the voltage applied across it is given by the relation $i = ke^n$ where i = instantaneous current, e is the instantaneous voltage and η is a constant whose value depends on the metal oxides used. The value of η for silicon-carbide-based varistors lies between 2 and 6 whereas zinc-oxide-based varistors have a value ranging from 25 to 50.

The zinc-oxide-based varistors are primarily used for protecting solid-state power supplies from low and medium surge voltage in the supply line. Silicon-carbide varistors provide protection against high-voltage surges caused by lightning and by the discharge of electromagnetic energy stored in the magnetic fields of large coils.

1.20. Short and Open Circuits

When two points of circuit are connected together by a thick metallic wire (Fig. 1.38), they are said to be *short-circuited*. Since 'short' has practically zero resistance, it gives rise to two important facts :

- (i) no voltage can exist across it because $V = IR = I \times 0 = 0$
- (ii) current through it (called short-circuit current) is very large (theoretically, infinity)

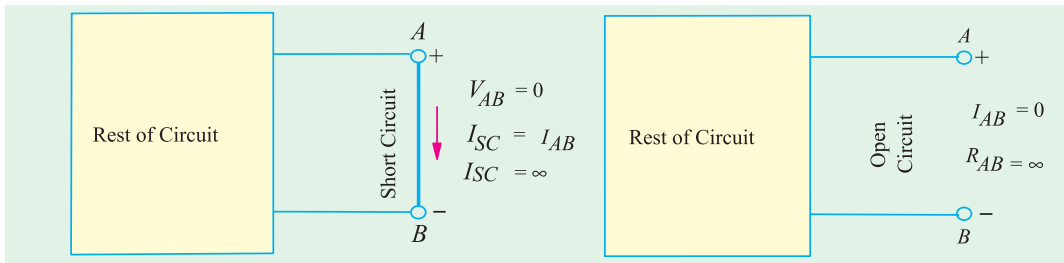

Fig. 1.38

Fig. 1.39

Two points are said to be open-circuited when there is no direct connection between them (Fig. 1.39). Obviously, an 'open' represents a break in the continuity of the circuit. Due to this break

- (i) resistance between the two points is infinite.
- (ii) there is no flow of current between the two points.

1.21. 'Shorts' in a Series Circuit

Since a dead (or solid) short has almost zero resistance, it causes the problem of excessive current which, in turn, causes power dissipation to increase many times and circuit components to burn out.

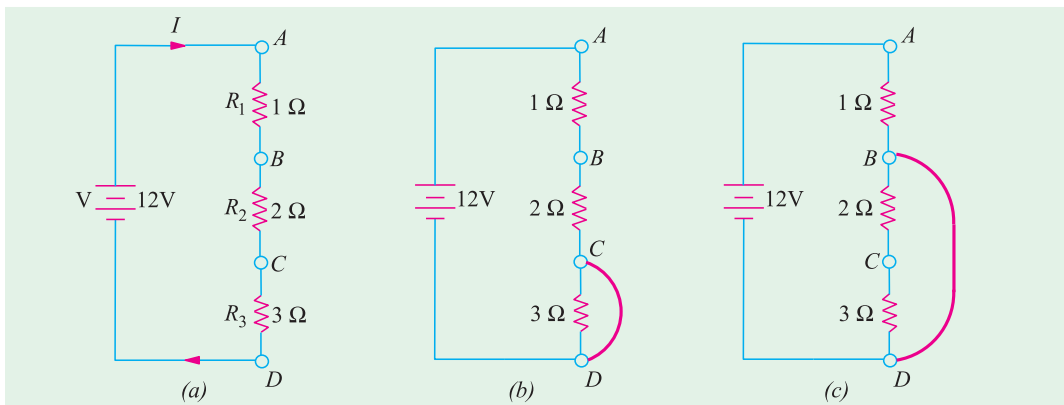

Fig. 1.40

In Fig. 1.40 (a) is shown a normal series circuit where

$$V = 12 \text{ V}, R = R_1 + R_2 + R_3 = 6 \Omega$$

$$I = V/R = 12/6 = 2 \text{ A}, P = I^2 R = 2^2 \times 6 = 24 \text{ W}$$

In Fig. 1.40 (b), 3- Ω resistor has been shorted out by a resistanceless copper wire so that $R_{CD} = 0$. Now, total circuit resistance $R = 1 + 2 + 0 = 3 \Omega$. Hence, $I = 12/3 = 4 \text{ A}$ and $P = 4^2 \times 3 = 48 \text{ W}$.

Fig. 1.40 (c) shows the situation where both 2 Ω and 3 Ω resistors have been shorted out of the circuit. In this case,

$$R = 1 \Omega, I = 12/1 = 12 \text{ A} \quad \text{and} \quad P = 12^2 \times 1 = 144 \text{ W}$$

Because of this excessive current (6 times the normal value), connecting wires and other circuit components can become hot enough to ignite and burn out.

1.22. 'Opens' in a Series Circuit

In a normal series circuit like the one shown in Fig. 1.41 (a), there exists a current flow and the voltage drops across different resistors are proportional to their resistances. If the circuit becomes 'open' anywhere, following two effects are produced :

(i) since 'open' offers infinite resistance, circuit current becomes zero. Consequently, there is no voltage drop across R_1 and R_2 .

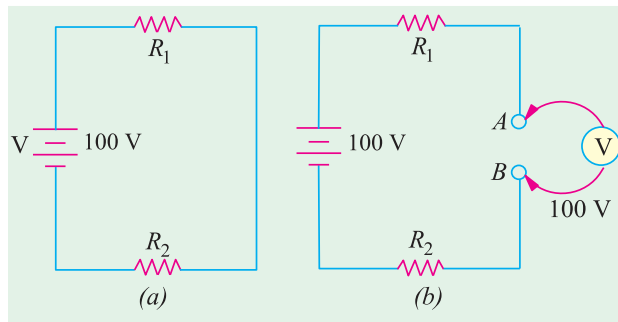

Fig. 1.41

(ii) *whole of the applied voltage (i.e. 100 V in this case) is felt across the 'open' i.e. across terminals A and B [Fig. 1.41 (b)].*

The reason for this is that R_1 and R_2 become negligible as compared to the infinite resistance of the 'open' which has practically whole of the applied voltage dropped across it (as per Voltage Divider Rule of art. 1.15). Hence, voltmeter in Fig. 1.41 (b) will read nearly 100 V i.e. the supply voltage.

1.23. 'Opens' in a Parallel Circuit

Since an 'open' offers infinite resistance, there would be no current in that part of the circuit where it occurs. In a parallel circuit, an 'open' can occur either in the main line or in any parallel branch.

As shown in Fig. 1.42 (a), an open in the main line prevents flow of current to *all branches*. Hence, neither of the two bulbs glows. However, full applied voltage (i.e. 220 V in this case) *is available across the open*.

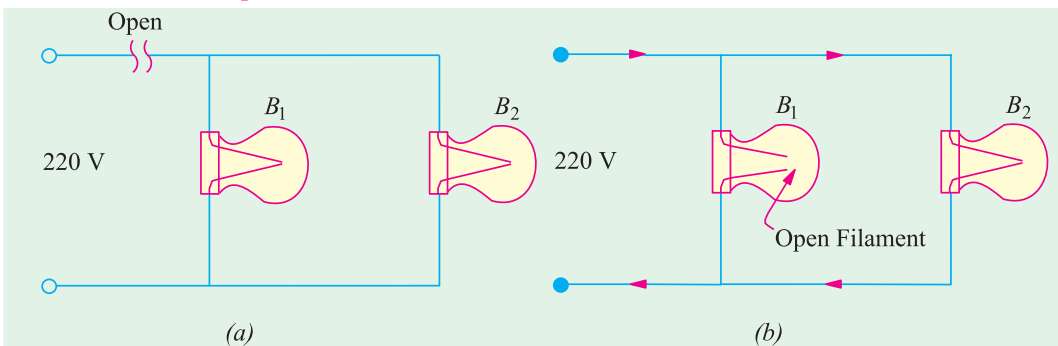

Fig. 1.42

In this Fig. 1.42 (b), 'open' has occurred in branch circuits of B_1 . Since there is no current in this branch, B_1 will not glow. However, as the other bulb remains connected across the voltage supply, it would keep operating normally.

It may be noted that if a voltmeter is connected across the open bulb, it will read full supply voltage of 220 V.

1.24. 'Shorts' in Parallel Circuits

Suppose a 'short' is placed across R_3 (Fig. 1.43). It becomes directly connected across the battery and draws almost infinite current because not only its own resistance but that of the connecting wires AC and BD is negligible. Due to this excessive current, the wires may get hot enough to burn out unless the circuit is protected by a fuse.

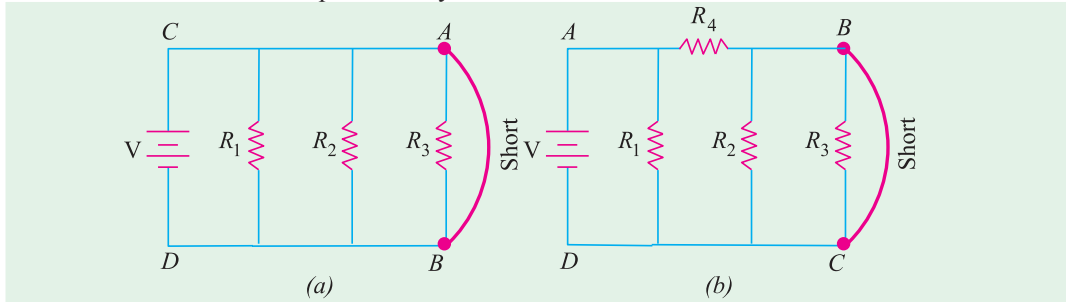

Fig. 1.43

Following points about the circuit of Fig. 1.43 (a) are worth noting.

1. not only is R_3 short-circuited but both R_1 and R_2 are also shorted out *i.e. short across one branch means short across all branches.*
2. there is no current in shorted resistors. If there were three bulbs, they will not glow.
3. the shorted components are not damaged, For example, if we had three bulbs in Fig. 1.43 (a), they would glow again when circuit is restored to normal conditions by removing the short-circuited.

It may, however, be noted from Fig. 1.43 (b) that a short-circuit across R_3 may short out R_2 but not R_1 since it is protected by R_4 .

1.25. Division of Current in Parallel Circuits

In Fig. 1.44, two resistances are joined in parallel across a voltage V . The current in each branch, as given in Ohm's law, is

$$I_1 = V/R_1 \text{ and } I_2 = V/R_2$$

$$\therefore \frac{I_1}{I_2} = \frac{R_1}{R_2}$$

$$\text{As } \frac{I}{R_1} = G_1 \text{ and } \frac{I}{R_2} = G_2$$

$$\therefore \frac{I_1}{I_2} = \frac{G_1}{G_2}$$

Hence, the division of current in the branches of a parallel circuit is directly proportional to the conductance of the branches or inversely proportional to their resistances. We may also express the branch currents in terms of the total circuit current thus :

$$\text{Now } I_1 + I_2 = I; \therefore I_2 = I - I_1 \quad \therefore \frac{I_1}{I - I_1} = \frac{R_2}{R_1} \text{ or } I_1 R_1 = R_2 (I - I_1)$$

$$\therefore I_1 = I \frac{R_1}{R_1 - R_2} = I \frac{G_1}{G_1 + G_2} \text{ and } I_2 = I \frac{R_1}{R_1 - R_2} = I \frac{G_1}{G_1 + G_2}$$

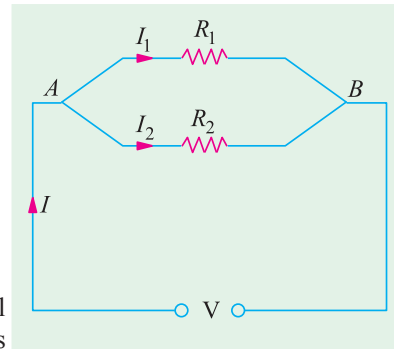

Fig. 1.44

This Current Divider Rule has direct application in solving electric circuits by Norton's theorem (Art. 2.25).

Take the case of three resistors in parallel connected across a voltage V (Fig. 1.45). Total current is $I = I_1 + I_2 + I_3$. Let the equivalent resistance be R . Then

$$V = IR$$

Also $V = I_1 R_1 \therefore IR = I_1 R_1$

or $\frac{I}{I_1} = \frac{R_1}{R}$ or $I_1 = IR/R_1 \dots (i)$

Now $\frac{I}{R} = \frac{I}{R_1} + \frac{I}{R_2} + \frac{I}{R_3}$

$$R = \frac{R_1 R_2 R_3}{R_2 R_3 + R_2 R_1 + R_1 R_3}$$

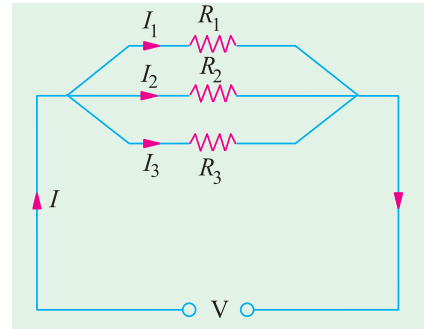

Fig. 1.45

From (i) above, $I_1 = I \left(\frac{R_2 R_3}{R_1 R_2 + R_2 R_3 + R_3 R_1} \right) = I \cdot \frac{G_1}{G_1 + G_2 + G_3}$

Similarly, $I_2 = I \frac{R_1 R_3}{R_1 R_2 + R_2 R_3 + R_3 R_1} = I \cdot \frac{G_2}{G_1 + G_2 + G_3}$

$$I_3 = I \frac{R_1 R_2}{R_1 R_2 + R_2 R_3 + R_3 R_1} = I \cdot \frac{G_3}{G_1 + G_2 + G_3}$$

Example 1.37. A resistance of 10Ω is connected in series with two resistances each of 15Ω arranged in parallel. What resistance must be shunted across this parallel combination so that the total current taken shall be 1.5 A with 20 V applied?

(Elements of Elect. Engg.-1; Bangalore Univ.)

Solution. The circuit connections are shown in Fig. 1.46.

Drop across $10\text{-}\Omega$ resistor = $1.5 \times 10 = 15 \text{ V}$

Drop across parallel combination, $V_{AB} = 20 - 15 = 5 \text{ V}$

Hence, voltage across each parallel resistance is 5 V .

$$I_1 = 5/15 = 1/3 \text{ A}, I_2 = 5/15 = 1/3 \text{ A}$$

$$I_3 = 1.5 - (1/3 + 1/3) = 5/6 \text{ A}$$

$$\therefore I_3 R = 5 \text{ or } (5/6) R = 5 \text{ or } R = 6 \Omega$$

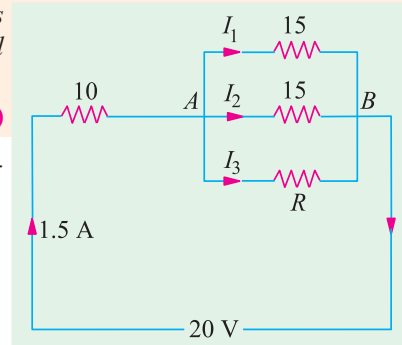

Fig. 1.46

Example 1.38. If 20 V be applied across AB shown in Fig. 1.40, calculate the total current, the power dissipated in each resistor and the value of the series resistance to have the total current.

(Elect. Science-II, Allahabad Univ. 1992)

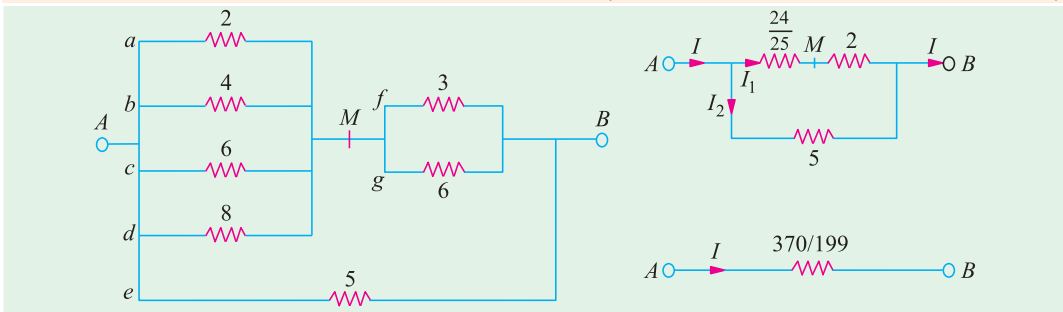

Fig. 1.47

Solution. As seen from Fig. 1.47. $R_{AB} = 370/199 \Omega$

Hence, total current $= 20 \div 370/199 = 10.76 \text{ A}$

$$I_1 = 10.76 \times 5(5 + 74.25) = 6.76 \text{ A}; I_2 = 10.76 - 6.76 = 4 \text{ A}$$

$$I_f = 6.76 \times 6/9 = 4.51 \text{ A}; I_g = 6.76 - 4.51 = 2.25 \text{ A}$$

Voltage drop across A and M , $V_{AM} = 6.76 \times 24/25 = 6.48 \text{ V}$

$$I_a = V_{AM}/2 = 6.48/2 = 3.24 \text{ A}; I_b = 6.48/4 = 1.62 \text{ A}; I_c = 6.48/6 = 1.08 \text{ A}$$

$$I_d = 6.48/8 = 0.81 \text{ A}, I_e = 20/5 = 4 \text{ A}$$

Power Dissipation

$$P_a = I_a^2 R_a = 3.24^2 \times 2 = 21 \text{ W}, P_b = 1.62^2 \times 4 = 10.4 \text{ W}, P_c = 1.08^2 \times 6 = 7 \text{ W}$$

$$P_d = 0.81^2 \times 8 = 5.25 \text{ W}, P_e = 4^2 \times 5 = 80 \text{ W}, P_f = 4.51^2 \times 3 = 61 \text{ W}$$

$$P_g = 2.25^2 \times 6 = 30.4 \text{ W}$$

The series resistance required is $370/199 \Omega$

Incidentally, total power dissipated $= I^2 R_{AB} = 10.76^2 \times 370/199 = 215.3 \text{ W}$ (as a check).

Example 1.39. Calculate the values of different currents for the circuit shown in Fig. 1.48. What is the total circuit conductance? and resistance?

Solution. As seen, $I = I_1 + I_2 + I_3$. The current division takes place at point B .

As seen from Art. 1.25.

$$I = I \cdot \frac{G_1}{G_1 + G_2 + G_3}$$

$$= 12 \times \frac{0.1}{0.6} = 2 \text{ A}$$

$$I_2 = 12 \times 0.2/0.6 = 4 \text{ A}$$

$$I_3 = 12 \times 0.3/0.6 = 6 \text{ A}$$

$$G_{BC} = 0.1 + 0.2 + 0.3 = 0.6 \text{ S}$$

$$\frac{1}{G_{AC}} = \frac{1}{G_{AB}} + \frac{1}{G_{BC}} = \frac{1}{0.4} + \frac{1}{0.6} = \frac{25}{6} \text{ S}^{-1} \therefore R_{AC} = 1/G_{AC} = 25/6 \Omega$$

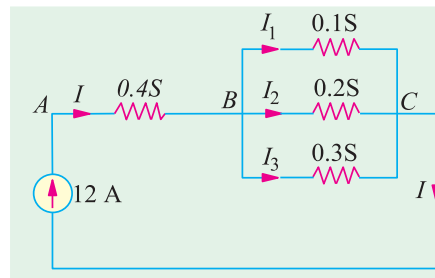

Fig. 1.48

Example 1.40. Compute the values of three branch currents for the circuits of Fig. 1.49 (a). What is the potential difference between points A and B ?

Solution. The two given current sources may be combined together as shown in Fig. 1.49 (b).

Net current $= 25 - 6 = 19 \text{ A}$ because the two currents flow in opposite directions.

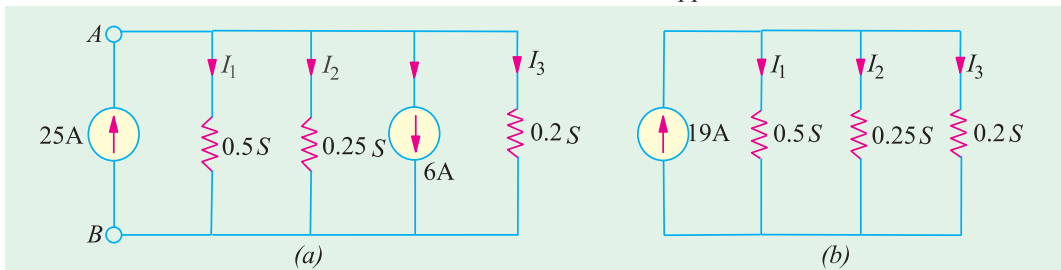

Fig. 1.49

Now, $G = 0.5 + 0.25 + 0.2 = 0.95 \text{ S}; I_1 = I \frac{G_1}{G} = 19 \times \frac{0.5}{0.95} = 10 \text{ A}$

$$I_2 = I \frac{G_2}{G} = 19 \times \frac{0.25}{0.95} = 5 \text{ A}; I_3 = I \frac{G_3}{G} = 19 \times \frac{0.2}{0.95} = 4 \text{ A}$$

$$V_{AB} = I_1 R_1 = \frac{I_1}{G_1} = \frac{I_2}{G_2} = \frac{I_3}{G_3} \therefore V_{AB} = \frac{10}{0.5} = 20 \text{ A}$$

The same voltage acts across the three conductances.

Example 1.41. Two conductors, one of copper and the other of iron, are connected in parallel and at 20°C carry equal currents. What proportion of current will pass through each if the temperature is raised to 100°C ? Assume α for copper as 0.0042 and for iron as 0.006 per $^\circ\text{C}$ at 20°C . Find also the values of temperature coefficients at 100°C .

(Electrical Engg. Madras Univ.)

Solution. Since they carry equal current at 20°C , the two conductors have the same resistance at 20°C i.e. R_{20} . As temperature is raised, their resistances increase through unequally.

$$\text{For Cu, } R_{100} = R_{20} (1 + 80 \times 0.0042) = 1.336 R_{20}$$

$$\text{For iron } R'_{100} = R_{20} (1 + 80 \times 0.006) = 1.48 R_{20}$$

As seen from Art. 1.25, current through Cu conductor is

$$I_1 = I \times \frac{R'_{100}}{R_{100} + R'_{100}} = I \times \frac{1.48 R_{20}}{2.816 R_{20}} = 0.5256 I \text{ or } 52.56\% \text{ of } I$$

Hence, current through Cu conductor is 52.56 per cent of the total current. Obviously, the remaining current i.e. 47.44 per cent passes through iron.

Or current through iron conductor is

$$I_2 = I \times \frac{R'_{100}}{R_{100} + R'_{100}} = I \times \frac{1.336 R_{20}}{2.816 R_{20}} = 0.4744 I \text{ or } 47.44\% \text{ of } I$$

$$\text{For Cu, } \alpha_{100} = \frac{1}{(1/0.0042) + 80} = 0.00314^\circ\text{C}^{-1}$$

$$\text{For iron, } \alpha_{100} = \frac{1}{(1/0.006) + 80} = 0.0040^\circ\text{C}^{-1}$$

Example 1.42. A battery of unknown e.m.f. is connected across resistances as shown in Fig. 1.50. The voltage drop across the 8Ω resistor is 20 V . What will be the current reading in the ammeter? What is the e.m.f. of the battery? (Basic Elect. Engg.; Bangladesh Univ., 1990)

Solution. Current through 8Ω resistance = $20/8 = 2.5 \text{ A}$

This current is divided into two parts at point A; one part going along path AC and the other along path ABC which has a resistance of 28Ω

$$I_2 = 2.5 \times \frac{11}{(11 + 28)} = 0.7$$

Hence, ammeter reads **0.7 A**.

Resistance between A and C = $(28 \times 11/39) \text{ ohm}$.

$$\text{Total circuit resistance} = 8 + 11 + (308/39) = 1049/39 \Omega$$

$$\therefore E = 2.5 \times 1049/39 = 67.3 \text{ V}$$

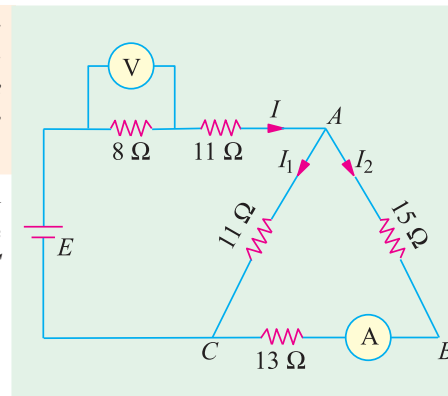
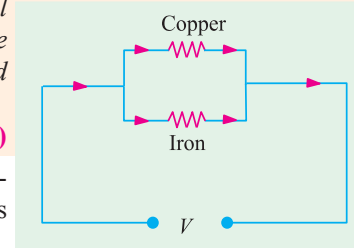

Fig. 1.50

1.26. Equivalent Resistance

The equivalent resistance of a circuit (or network) between its any two points (or terminals) is given by that *single* resistance which can replace the entire given circuit between *these two points*. It should be noted that resistance is always between two *given* points of a circuit and can have different

values for different point-pairs as illustrated by Example 1.42. it can usually be found by using series and parallel laws of resistances. Concept of equivalent resistance is essential for understanding network theorems like Thevenin's theorem and Norton's theorem etc. discussed in Chapter 2.

Example 1.43. Find the equivalent resistance of the circuit given in Fig. 1.51 (a) between the following points (i) A and B (ii) C and D (iii) E and F (iv) A and F and (v) A and C. Numbers represent resistances in ohm.

Solution. (i) Resistance Between A and B

In this case, the entire circuit to the right side of AB is in parallel with 1 Ω resistance connected directly across points A and B.

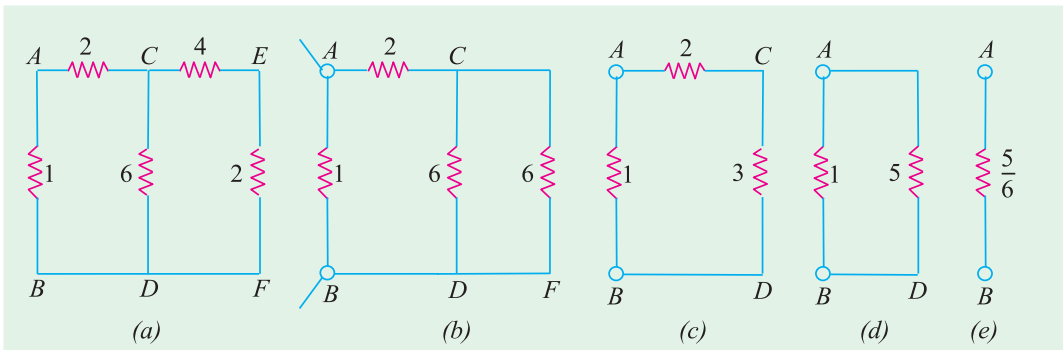

Fig. 1.51

As seen, there are two parallel paths across points C and D; one having a resistance of 6 Ω and the other of (4 + 2) = 6 Ω. As shown in Fig. 1.51 (c), the combined resistance between C and D is = 6 || 6 = 3 Ω. Further simplifications are shown in Fig. 1.51 (d) and (e). As seen, $R_{AD} = 5/6 \Omega$

(ii) Resistance between C and D

As seen from Fig. 1.51 (a), there are three parallel paths between C and D (i) CD itself of 6 Ω (ii) CEFD of (4 + 2) = 6 Ω and (iii) CABD of (2 + 1) = 3 Ω. It has been shown separately in Fig. 1.52 (a). The equivalent resistance $R_{CD} = 3 || 6 || 6 = 1.5 \Omega$ as shown in Fig. 1.52 (b).

(iii) Resistance between E and F

In this case, the circuit to the left side of EF is in parallel with the 2 Ω resistance connected directly across E and F. This circuit consists of a 4 Ω resistance connected in series with a parallel

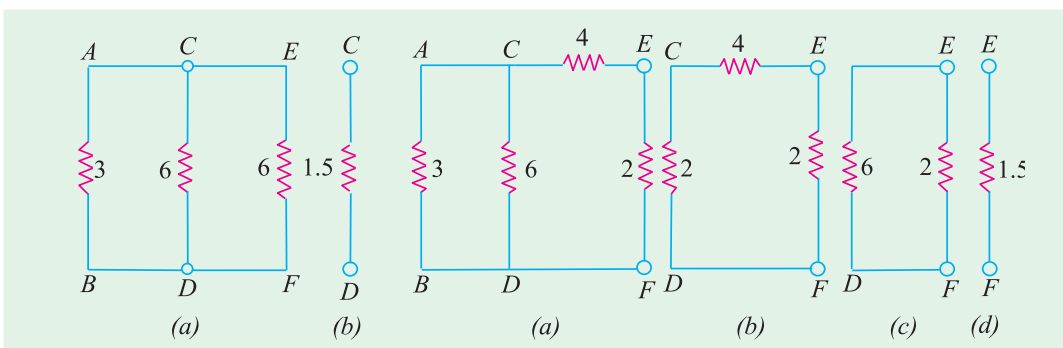

Fig. 1.52

Fig. 1.53

circuit of 6 || (2 + 1) = 2 Ω resistance. After various simplifications as shown in Fig. 1.53, $R_{EF} = 2 || 6 = 1.5 \Omega$

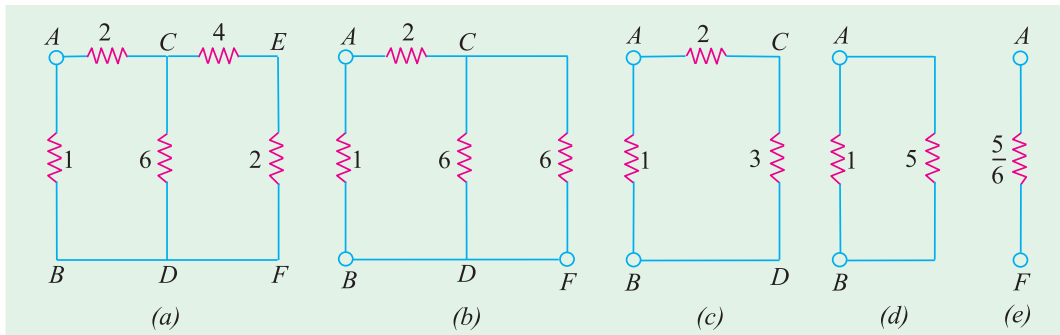

Fig. 1.54

(iv) Resistance Between A and F

As we go from A and F , there are two possible routes to begin with: one along $ABDF$ and the other along AC . At point C , there are again two alternatives, one along CDF and the other along CEF .

As seen from Fig. 1.54 (b), $R_{CD} = 6 \parallel 6 = 3 \Omega$. Further simplification of the original circuit as shown in Fig. 1.54 (c), (d) and (e) gives $R_{AF} = 5/6 \Omega$

(v) Resistance Between A and C

In this case, there are two parallel paths between A and C ; one is directly from A to C and the other is along ABD . At D , there are again two parallel paths to C ; one is directly along DC and the other is along $DFEC$.

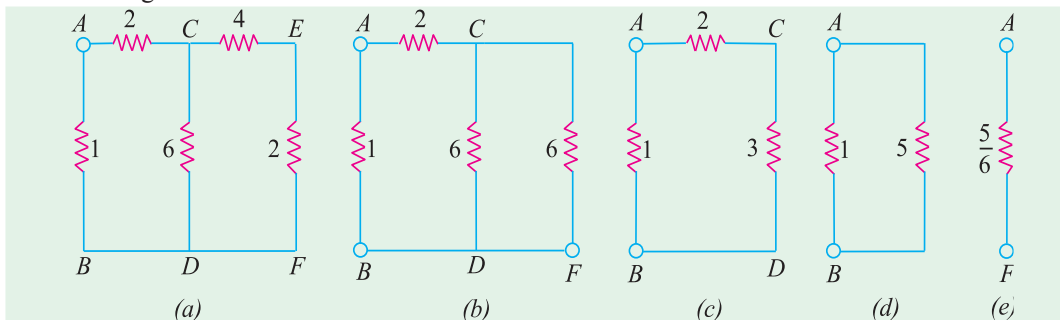

Fig. 1.55

As seen from Fig. 1.55 (b), $R_{CD} = 6 \parallel 6 = 3 \Omega$. Again, from Fig. 1.55 (d), $R_{AC} = 2 \parallel 4 = 4/3 \Omega$

Example 1.44. Two resistors of values $1 \text{ k}\Omega$ and $4 \text{ k}\Omega$ are connected in series across a constant voltage supply of 100 V . A voltmeter having an internal resistance of $12 \text{ k}\Omega$ is connected across the $4 \text{ k}\Omega$ resistor. Draw the circuit and calculate

- true voltage across $4 \text{ k}\Omega$ resistor before the voltmeter was connected.
- actual voltage across $4 \text{ k}\Omega$ resistor after the voltmeter is connected and the voltage recorded by the voltmeter.
- change in supply current when voltmeter is connected.
- percentage error in voltage across $4 \text{ k}\Omega$ resistor.

Solution. (a) True voltage drop across $4 \text{ k}\Omega$ resistor as found by voltage-divider rule is $100 \times 4/5 = 80 \text{ V}$

Current from the supply = $100/(4 + 1) = 20 \text{ mA}$

(b) In Fig. 1.56, voltmeter has been joined across the $4 \text{ k}\Omega$ resistor. The equivalent resistance between B and $C = 4 \times 12/16 = 3 \text{ k}\Omega$

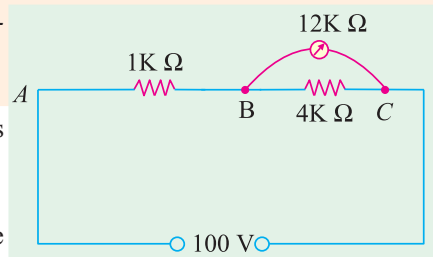

Fig. 1.56

Drop across B and $C = 100 \times 3/(3 + 1) = 75$ V.

(c) Resistance between A and $C = 3 + 1 = 4$ k Ω

New supply current = $100/4 = 25$ mA

\therefore increase in current = $25 - 20 = 5$ mA

(d) Percentage error in voltage = $\frac{\text{actual voltage} - \text{true voltage}}{\text{true voltage}} = \frac{(75 - 80)}{80} \times 100 = -6.25\%$

The reduction in the value of voltage being measured is called voltmeter loading effect because voltmeter loads down the circuit element across which it is connected. Smaller the voltmeter resistance as compared to the resistance across which it is connected, greater the loading effect and, hence, greater the error in the voltage reading. Loading effect cannot be avoided but can be minimized by selecting a voltmeter of resistance much greater than that of the network across which it is connected.

Example 1.45. In the circuit of Fig. 1.57, find the value of supply voltage V so that 20- Ω resistor can dissipate 180 W.

Solution. $I_4^2 \times 20 = 180$ W; $I_4 = 3$ A

Since 15 Ω and 20 Ω are in parallel,

$$I_3 \times 15 = 3 \times 20 \quad \therefore I_3 = 4$$
 A

$$I_2 = I_3 + I_4 = 4 + 3 = 7$$
 A

Now, resistance of the circuit to the right of point A is

$$= 10 + 15 \times 20/35 = 130/7 \Omega$$

$$\therefore I_1 \times 25 = 7 \times 130/7$$

$$\therefore I_1 = 26/5 \text{ A} = 5.2 \text{ A}$$

$$\therefore I = I_1 + I_2 = 5.2 + 7 = 12.2 \text{ A}$$

Total circuit resistance

$$R_{AE} = 5 + 25 \parallel 130/7 = 955/61 \Omega$$

$$\therefore V = I \cdot R_{AE} = 12.2 \times 955/61 = 191 \text{ V}$$

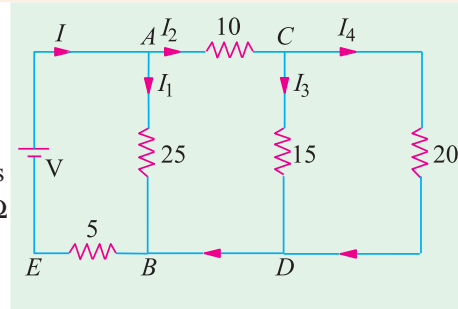

Fig. 1.57

Example 1.46. For the simple ladder network shown in Fig. 1.58, find the input voltage V_i which produces a current of 0.25 A in the 3 Ω resistor. All resistances are in ohm.

Solution. We will assume a current of 1 A in the 3 Ω resistor. The voltage necessary to produce 1 A bears the same ratio to 1 A as V_i does to 0.25 A because of the linearity of the network. It is known as Current Assumption technique.

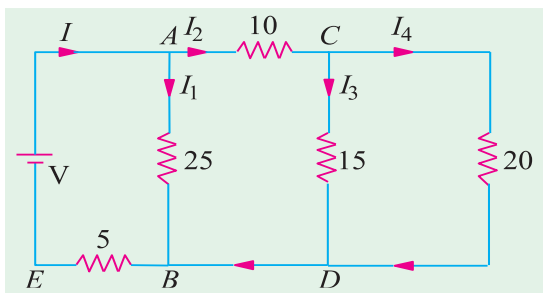

Fig. 1.58

Taking the proportion, we get

$$\frac{80}{1} = \frac{V_i}{0.25} \quad \therefore V_i = 80 \times 0.25 = 20 \text{ V}$$

Since $R_{cdef} = R_{cf} = 6 \Omega$

Hence, $I_{cf} = 1$ A

and $V_{cf} = V_{cdef} = 1 \times 6 = 6$ V.

Also, $I_{bc} = 1 + 1 = 2$ A

$$V_{bg} = V_{bb} + V_{ef} = 2 \times 5 + 6 = 16 \text{ V}$$

$$I_{bg} = 16/8 = 2 \text{ A}$$

$$I_{ab} = I_{bc} + I_{bg} = 2 + 2 = 4 \text{ A}$$

$$V_i = V_{ab} + V_{bg} + V_{gh} \\ = 4 \times 7 + 16 + 4 \times 9 = 80 \text{ V}$$

Example 1.47. In this circuit of Fig. 1.59, find the value R_1 and R_2 so that $I_2 = I_1/n$ and the input resistance as seen from points A and B is R ohm.

Solution. As seen, the current through R_2 is $(I_1 - I_2)$. Hence, p.d. across points C and D is $R_2(I_1 - I_2) = (R_1 + R)I_2$ or $R_2 I_1 = (R_1 + R_2 + R)I_2$

$$\therefore \frac{I_1}{I_2} = \frac{R_1 + R_2 + R}{R_2} = n \quad \dots(i)$$

The input resistance of the circuit as viewed from terminals A and B is required to be R .

$$\begin{aligned} \therefore R &= R_1 + R_2 \parallel (R_1 + R) \\ &= R_1 + \frac{R_1 + R}{n} \quad \dots \text{using Eq. (i)} \end{aligned}$$

$$R(n-1) = R_1(n+1)$$

$$\therefore R_1 = \frac{n-1}{n+1}R \quad \text{and} \quad R_2 = \frac{R_1 + R}{(n-1)} = \frac{2n}{n^2 - 1}R$$

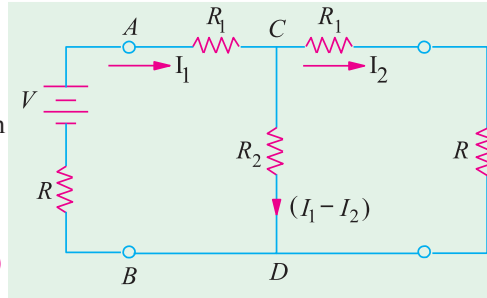

Fig. 1.59

1.27. Duality Between Series and Parallel Circuits

There is a certain peculiar pattern of relationship between series and parallel circuits. For example, in a series circuit, current is the same whereas in a parallel circuit, voltage is the same. Also, in a series circuit, individual voltages are added and in a parallel circuit, individual currents are added. It is seen that while comparing series and parallel circuits, voltage takes the place of current and current takes the place of voltage. Such a pattern is known as “duality” and the two circuits are said to be duals of each other.

As arranged in Table 1.4 the equations involving voltage, current and resistance in a series circuit have a corresponding dual counterparts in terms of current, voltage and conductance for a parallel circuit.

Table 1.4

Series Circuit	Parallel Circuit
$I_1 = I_2 = I_3 = \dots\dots\dots$	$V_1 = V_2 = V_3 = \dots\dots\dots$
$V_T = V_1 + V_2 + V_3 + \dots\dots\dots$	$I_1 = I_1 + I_2 + I_3 + \dots\dots\dots$
$R_T = R_1 + R_2 + R_3 + \dots\dots\dots$	$G_T = G_1 + G_2 + G_3 + \dots\dots\dots$
$I = \frac{V_1}{R_1} = \frac{V_2}{R_2} = \frac{V_3}{R_3} = \dots\dots\dots$	$V = \frac{I_1}{G_1} = \frac{I_2}{G_2} = \frac{I_3}{G_3} = \dots\dots\dots$
Voltage Divider Rule $V_1 = V_T \frac{R_1}{R_T}, V_2 = V_T \frac{R_2}{R_T}$	Current Divider Rule $I_1 = I_T \frac{G_1}{G_T}, I_2 = I_T \frac{G_2}{G_T}$

Tutorial Problems No. 1.4

1. Using the current-divider rule, find the ratio I_L/I_S in the circuit shown in Fig. 1.60.

[0.25]

2. Find the values of variables indicated in the circuit of Fig. 1.61. All resistances are in ohms.

[(a) 40 V (b) 21 V; 15 V (c) -5 A; 3 A]

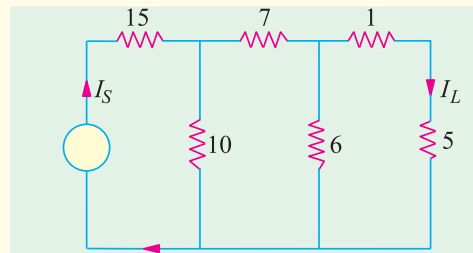

Fig. 1.60

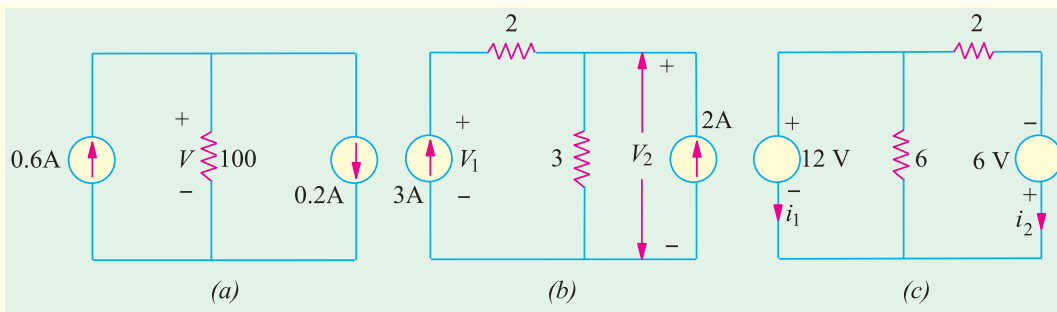

Fig. 1.61

3. An ohmmeter is used for measuring the resistance of a circuit between its two terminals. What would be the reading of such an instrument used for the circuit of Fig. 1.62 at point (a) AB (b) AC and (c) BC ? All resistances are in ohm.

[(a) 25 Ω (b) 24 Ω (c) 9 Ω]

4. Find the current and power supplied by the battery to the circuit of Fig. 1.63 (i) under normal conditions and (ii) when a 'short' occurs across terminals A and B . All resistances are in kilo-ohm.

[(i) 2 mA; 24 mW; (ii) 34 mA; 36 mW]

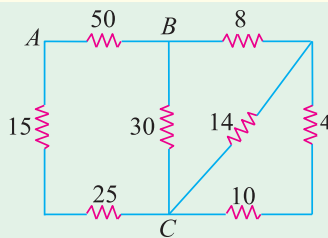

Fig. 1.62

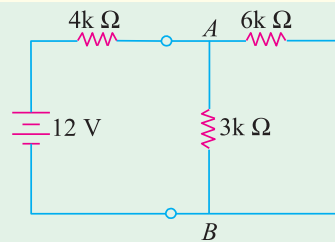

Fig. 1.63

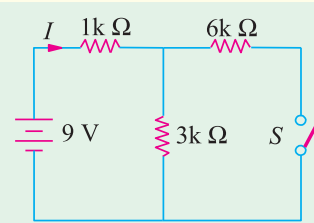

Fig. 1.64

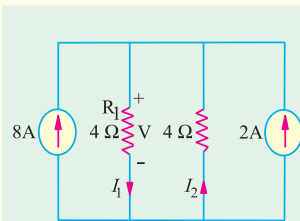

Fig. 1.65

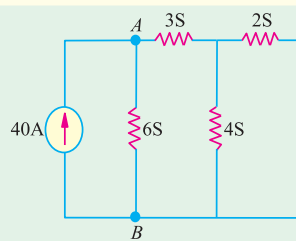

Fig. 1.66

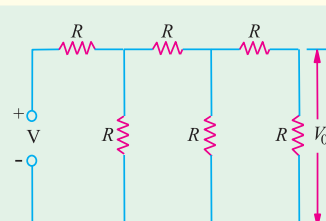

Fig. 1.67

5. Compute the values of battery current I and voltage drop across 6 k Ω resistor of Fig. 1.64 when switch S is (a) closed and (b) open. All resistance values are in kilo-ohm.

[(a) 3mA; 6 V; (b) 2.25 mA; 0V]

6. For the parallel circuit of Fig. 1.65 calculate (i) V (ii) I_1 (iii) I_2 .

[(i) 20 V; (ii) 5 A; (iii) -5 A]

7. Find the voltage across terminals A and B of the circuit shown in Fig. 1.66. All conductances are in siemens (S).

[5 V]

8. Prove that the output voltage V_0 in the circuit of Fig. 1.67 is $V/13$.

9. A fault has occurred in the circuit of Fig. 1.68. One resistor has burnt out and has become an open. Which is the resistor if current supplied by the battery is 6 A? All resistances are in ohm.

[4 Ω]

10. In Fig. 1.69 if resistance between terminals A and B measures 1000 Ω , which resistor is open-circuited. All conductance values are in milli-siemens (mS).

[0.8 mS]

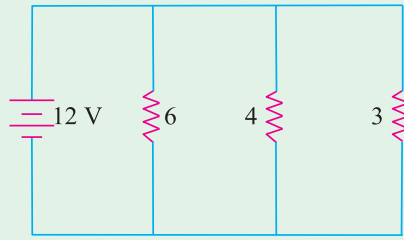

Fig. 1.68

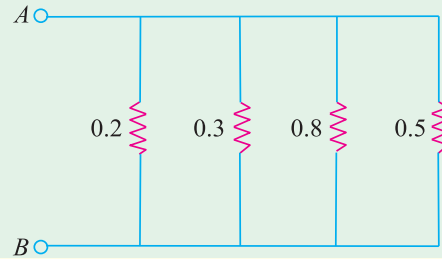

Fig. 1.69

11. In the circuit of Fig. 1.70, find current (a) I and (b) I_1 . [(a) 2 A; (b) 0.5 A]

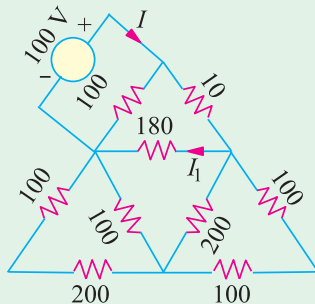

Fig. 1.70

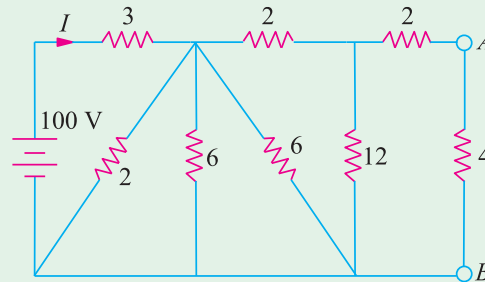

Fig. 1.71

12. Deduce the current I in the circuit of Fig. 1.71. All resistances are in ohms. [25 A]
13. Two resistors of $100\ \Omega$ and $200\ \Omega$ are connected in series across a 4-V cell of negligible internal resistance. A voltmeter of $200\ \Omega$ resistance is used to measure P.D. across each. What will the voltage be in each case? [1 V across $100\ \Omega$; 2 V across $200\ \Omega$]
14. Using series-parallel combination laws, find the resistance between terminals A and B of the network shown in Fig. 1.72. [4 R]

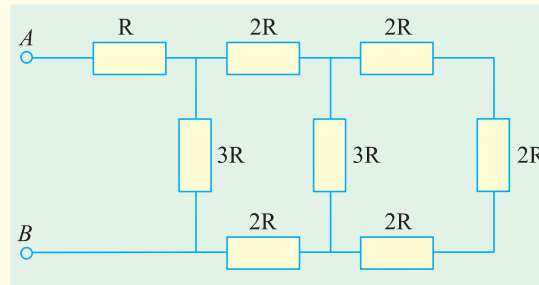

Fig. 1.72

15. A resistance coil AB of $100\ \Omega$ resistance is to be used as a potentiometer and is connected to a supply at 230 V. Find, by calculation, the position of a tapping point C between A and B such that a current of 2 A will flow in a resistance of $50\ \Omega$ connected across A and C . [43.4 Ω from A to C] (London Univ.)
16. In the circuit shown in Fig. 1.73, calculate (a) current I (b) current I_1 and (c) V_{AB} . All resistances are in ohms. [(a) 4 A (b) 0.25 A (c) 4 V]

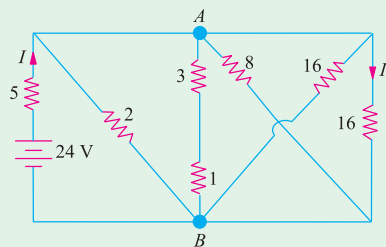

Fig. 1.73

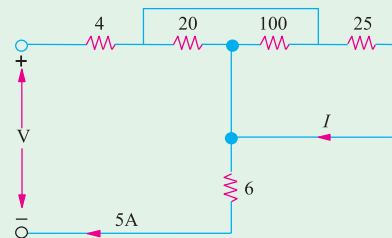

Fig. 1.74

17. In the circuit given in Fig. 1.74, calculate (a) current through the $25\ \Omega$ resistor (b) supply voltage V . All resistances are in ohms. **[(a) 2 A (b) 100 V]**
18. Using series and parallel combinations for the electrical network of Fig. 1.75, calculate (a) current flowing in branch AF (b) p.d. across branch CD . All resistances are in ohms. **[(a) 2 A (b) 1.25 V]**

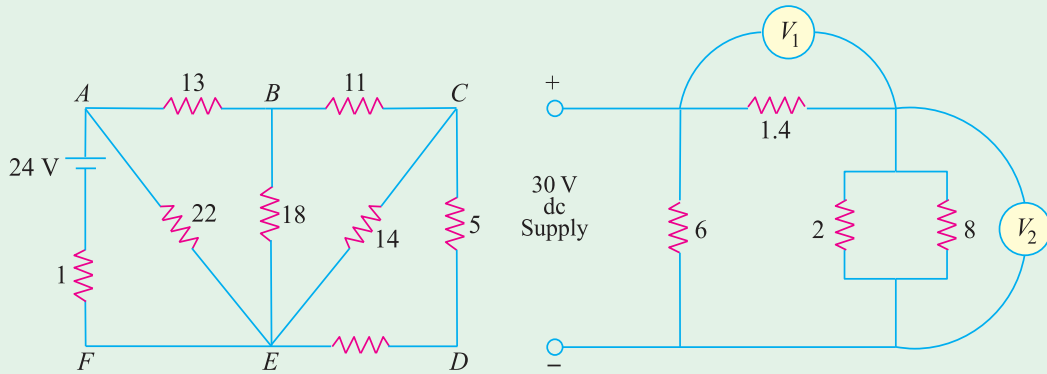

Fig. 1.75

Fig. 1.76

19. Neglecting the current taken by voltmeters V_1 and V_2 in Fig. 1.76, calculate (a) total current taken from the supply (b) reading on voltmeter V_1 and (c) reading on voltmeter V_2 .

[(a) 15 A (b) 14 V (c) 16 V]

20. Find the equivalent resistance between terminals A and B of the circuit shown in Fig. 1.77. Also, find the value of currents I_1 , I_2 , and I_3 . All resistances are in ohm.

[8 Ω ; $I_1 = 2\text{ A}$; $I_2 = 0.6\text{ A}$; $I_3 = 0.4\text{ A}$]

21. In Fig. 1.78, the $10\ \Omega$ resistor dissipates 360 W. What is the voltage drop across the $5\ \Omega$ resistor? **[30 V]**

22. In Fig. 1.79, the power dissipated in the $10\ \Omega$ resistor is 250 W. What is the total power dissipated in the circuit? **[850 W]**

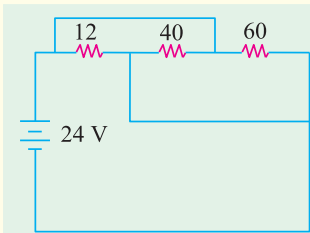

Fig. 1.77

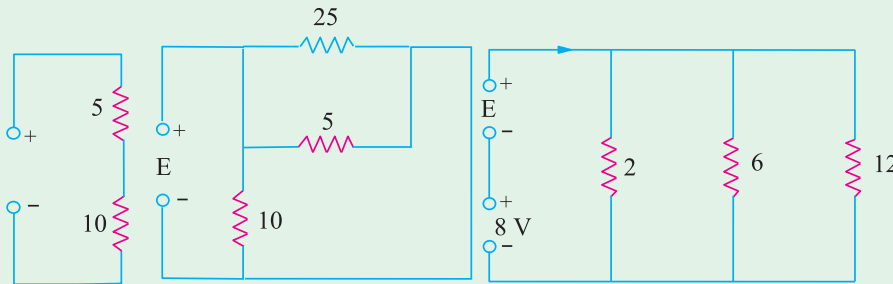

Fig. 1.78

Fig. 1.79

Fig. 1.80

23. What is the value of E in the circuit of Fig. 1.80? All resistances are in ohms. **[4 V]**

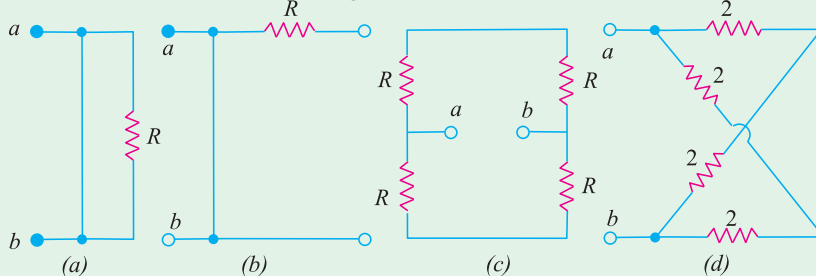

Fig. 1.81

24. Find the equivalent resistance R_{a-b} at the terminals $a-b$ of the networks shown in Fig. 1.81.

[(a) 0 (b) 0 (c) R (d) $2\ \Omega$]

25. Find the equivalent resistance between terminals a and b of the circuit shown in Fig. 1.82 (a). Each resistor has a value of $1\ \Omega$.

[5/11 Ω]

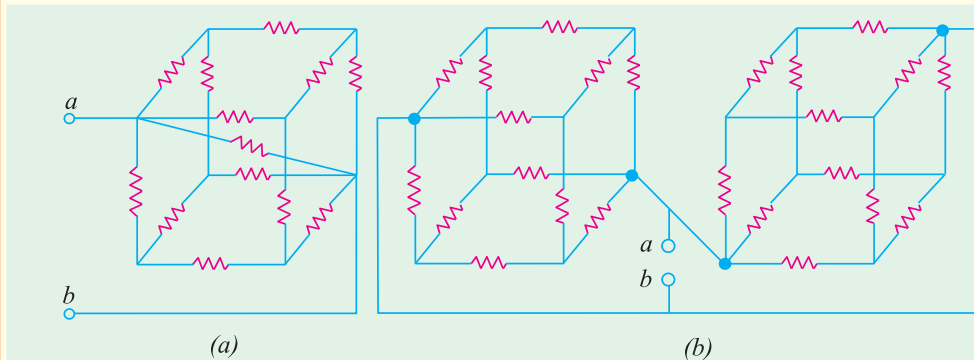

Fig. 1.82

26. Find the equivalent resistance between terminals a and b of the circuit shown in Fig. 1.82 (b). Each resistor has a value of $1\ \Omega$.

[5/12 Ω]

27. Two resistors of value $1000\ \Omega$ and $4000\ \Omega$ are connected in series across a constant voltage supply of $150\ \text{V}$. Find (a) p.d. across $4000\ \Omega$ resistor (b) calculate the change in supply current and the reading on a voltmeter of $12,000\ \Omega$ resistance when it is connected across the larger resistor.

[(a) $120\ \text{V}$ (b) $7.5\ \text{mA}$; $112.5\ \text{V}$]

1.28. Relative Potential

It is the voltage of one point in a circuit with respect to that of another point (usually called the reference or common point).

Consider the circuit of Fig. 1.83 (a) where the most negative end-point C has been taken as the reference. With respect to point C , both points A and B are positive though A is more positive than B . The voltage of point B with respect to that of C i.e. $V_{BC} = +30\ \text{V}$.

Similarly, $V_{AC} = +(20 + 30) = +50\ \text{V}$.

In Fig. 1.83 (b), the most positive end point A has been taken as the reference point. With respect to A , both B and C are negative though C is more negative than B .

$V_{BA} = -20\ \text{V}$, $V_{CA} = -(20 + 30) = -50\ \text{V}$

In Fig. 1.83 (c), mid-point B has been taken as the reference point. With respect to B , A is at positive potential whereas C is at a negative potential.

Hence, $V_{AB} = +20\ \text{V}$ and $V_{CB} = -30\ \text{V}$ (of course, $V_{BC} = +30\ \text{V}$)

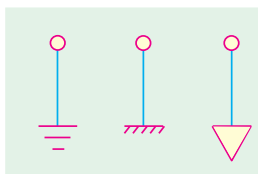

Fig. 1.84

It may be noted that **any point** in the circuit can be chosen as the reference point to suit our requirements. This point is often called **ground** or **earth** because originally it meant a point in a circuit which was **actually** connected to earth either for safety in power systems or for efficient radio reception and transmission. Although, this meaning still exists, yet it has become usual today for **'ground'** to mean any point in the circuit which is connected to a large metallic object such as the metal chassis of a transmit-

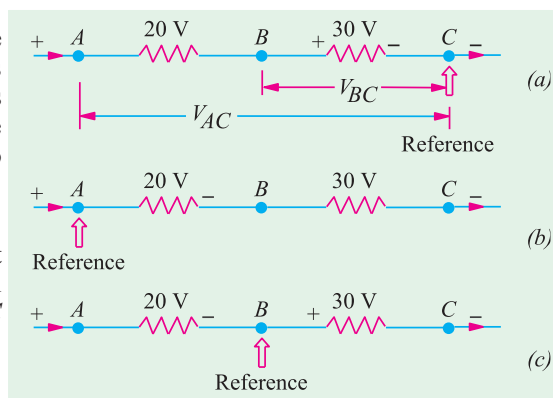

Fig. 1.83

ter, the aluminium chassis of a receiver, a wide strip of copper plating on a printed circuit board, frame or cabinet which supports the whole equipment. Sometimes, reference point is also called **common** point. The main advantage of using a ground system is to simplify our circuitry by saving on the amount of wiring because ground is used as the return path for many circuits. The three commonly-used symbols for **ground** are shown in Fig. 1.84.

Example 1.48. In Fig. 1.85, calculate the values of (i) V_{AF} (ii) V_{EA} and (iii) V_{FB} .

Solution. It should be noted that V_{AF} stands for the potential of point A with respect to point F . The easiest way of finding it is to start from the reference point F and go to point A along any available path and calculate the algebraic sum of the voltages met on the way. Starting from point F as we go to point A , we come across different battery voltages. Taking the sign convention given in Art. 1.28, we get

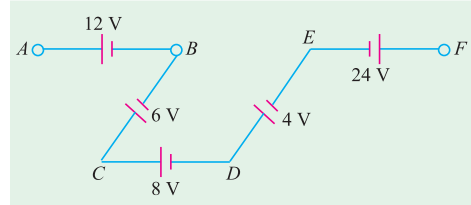

Fig. 1.85

$$(i) \quad V_{AF} = -24 + 4 + 8 - 6 + 12 = -6 \text{ V}$$

The negative sign shows that point A is negative with respect to point F by 6 V.

$$(ii) \quad \text{Similarly,} \quad V_{EA} = -12 + 6 - 8 - 4 = -18 \text{ V}$$

$$(iii) \quad \text{Starting from point } B, \text{ we get } V_{FB} = 6 - 8 - 4 + 24 = 18 \text{ V.}$$

Since the result is positive it means that point F is at a higher potential than point B by 18 V.

Example 1.49. In Fig. 1.86 compute the relative potentials of points A , B , C , D and E which (i) point A is grounded and (ii) point D is grounded. Does it affect the circuit operation or potential difference between any pair of points?

Solution. As seen, the two batteries have been connected in *series opposition*. Hence, net circuit voltage = $34 - 10 = 24 \text{ V}$
 Total circuit resistance = $6 + 4 + 2 = 12 \Omega$
 Hence, the circuit current = $24/12 = 2 \text{ A}$
 Drop across 2Ω resistor = $2 \times 2 = 4 \text{ V}$, Drop across 4Ω resistor = $2 \times 4 = 8 \text{ V}$
 Drop across 6Ω resistor = $2 \times 6 = 12 \text{ V}$

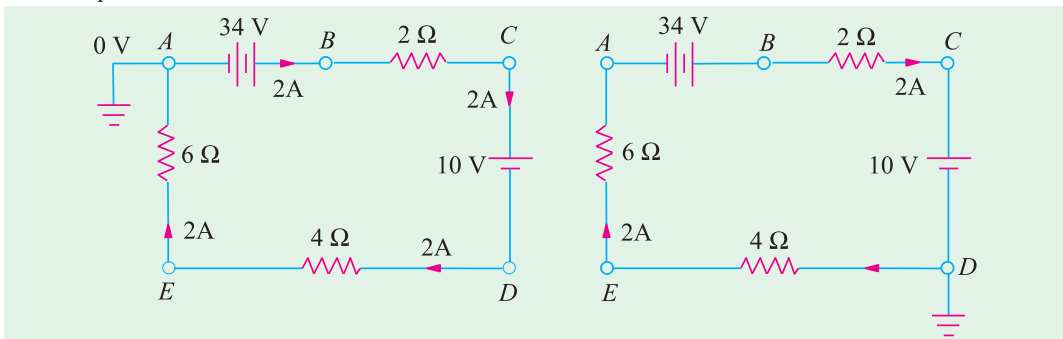

Fig. 1.86

Fig. 1.87

(i) Since point B is directly connected to the positive terminal of the battery whose negative terminal is earthed, hence $V_B = +34 \text{ V}$.

$$\text{Since there is a fall of } 4 \text{ V across } 2 \Omega \text{ resistor, } V_C = 34 - 4 = 30 \text{ V}$$

As we go from point C to D i.e. from positive terminal of 10-V battery to its negative terminal, there is a *decrease* in potential of 10 V. Hence, $V_D = 30 - 10 = 20$ i.e. point D is 20 V above the ground A .

$$\text{Similarly,} \quad V_E = V_D - \text{voltage fall across } 4 \Omega \text{ resistor} = 20 - 8 = +12 \text{ V}$$

Also $V_A = V_E$ -fall across $6\ \Omega$ resistor = $12(2 \times 6) = 0\ \text{V}$

(ii) In Fig. 1.87, point D has been taken as the ground. Starting from point D , as we go to E there is a fall of $8\ \text{V}$. Hence, $V_E = -8\ \text{V}$. Similarly, $V_A = -(8 + 12) = -20\ \text{V}$.

As we go from A to B , there is a sudden increase of $34\ \text{V}$ because we are going from negative terminal of the battery to its positive terminal.

$$\therefore \begin{aligned} V_B &= -20 + 34 = +14\ \text{V} \\ V_C &= V_B - \text{voltage fall across } 2\ \Omega \text{ resistor} = 14 - 4 = +10\ \text{V}. \end{aligned}$$

It should be so because C is connected directly to the positive terminal of the $10\ \text{V}$ battery.

Choice of a reference point does not in any way affect the operation of a circuit. Moreover, it also does not change the voltage across any resistor or between any pair of points (as shown below) because the ground current $i_g = 0$.

Reference Point A

$$\begin{aligned} V_{CA} &= V_C - V_A = 30 - 0 = +30\ \text{V}; V_{CE} = V_C - V_E = 30 - 12 = +18\ \text{V} \\ V_{BD} &= V_B - V_D = 34 - 20 = +14\ \text{V} \end{aligned}$$

Reference Point D

$$\begin{aligned} V_{CA} &= V_C - V_A = 10 - (-20) = +30\ \text{V}; V_{CE} = V_C - V_E = 10 - (-8) = +18\ \text{V} \\ V_{BD} &= V_B - V_D = 14 - 0 = +14\ \text{V} \end{aligned}$$

Example 1.50. Find the voltage V in Fig. 1.88 (a). All resistances are in ohms.

Solution. The given circuit can be simplified to the final form shown in Fig. 1.88 (d). As seen, current supplied by the battery is $1\ \text{A}$. At point A in Fig. 1.88 (b), this current is divided into two equal parts of $0.5\ \text{A}$ each.

Obviously, voltage V represents the potential of point B with respect to the negative terminal of the battery. Point B is above the ground by an amount equal to the voltage drop across the series combination of $(40 + 50) = 90\ \Omega$

$$V = 0.5 \times 90 = 45\ \text{V}.$$

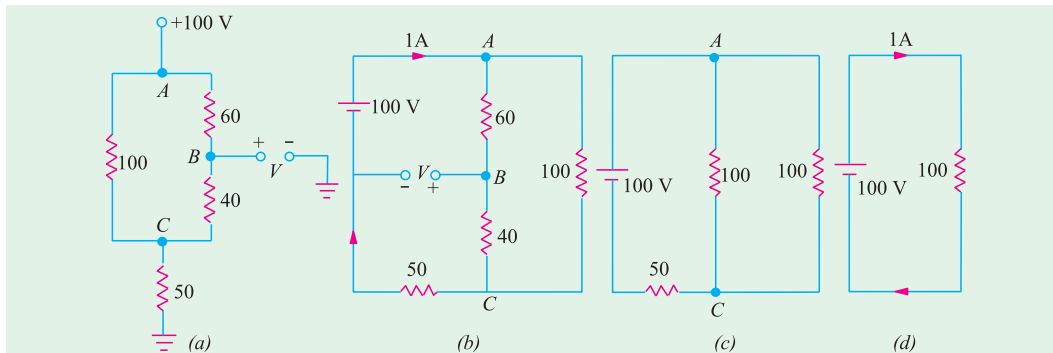

Fig. 1.88

1.29. Voltage Divider Circuit

A voltage divider circuit (also called potential divider) is a series network which is used to feed other networks with a number of different voltages and derived from a single input voltage source.

Fig. 1.89 (a) shows a simple voltage divider circuit which provides two output voltages V_1 and V_2 . Since no load is connected across the output terminals, it is called an **unloaded** voltage divider.

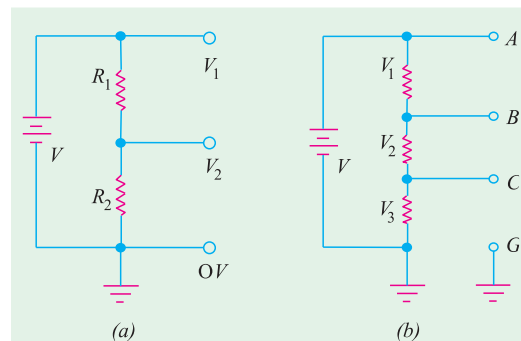

Fig. 1.89

As seen from Art. 1.15.

$$V_1 = V \frac{R_1}{R_1 + R_2} \text{ and } V_2 = V \cdot \frac{R_2}{R_1 + R_2}$$

The ratio V_2/V is also known as voltage-ratio **transfer function**.

$$\text{As seen, } \frac{V_2}{V} = \frac{R_2}{R_1 + R_2} = \frac{1}{1 + R_1/R_2}$$

The voltage divider of Fig. 1.89 (b) can be used to get six different voltages :

$$V_{CG} = V_3, V_{BC} = V_2, V_{AB} = V_1, V_{BG} = (V_2 + V_3), V_{AC} = (V_1 + V_2) \text{ and } V_{AG} = V$$

Example 1.51. Find the values of different voltages that can be obtained from a 12-V battery with the help of voltage divider circuit of Fig. 1.90.

Solution. $R = R_1 + R_2 + R_3 = 4 + 3 + 1 = 8 \Omega$
 Drop across $R_1 = 12 \times 4/8 = 6 \text{ V}$
 $\therefore V_B = 12 - 6 = 6 \text{ V}$ above ground
 Drop across $R_2 = 12 \times 3/8 = 4.5 \text{ V}$
 $\therefore V_C = V_B - 4.5 = 6 - 4.5 = 1.5$
 Drop across $R_3 = 12 \times 1/8 = 1.5 \text{ V}$

Different available load voltages are :

- (i) $V_{AB} = V_A - V_B = 12 - 6 = 6 \text{ V}$
- (ii) $V_{AC} = 12 - 1.5 = 10.5 \text{ V}$
- (iii) $V_{AD} = 12 \text{ V}$
- (iv) $V_{BC} = 6 - 1.5 = 4.5 \text{ V}$
- (v) $V_{CD} = 1.5 \text{ V}$

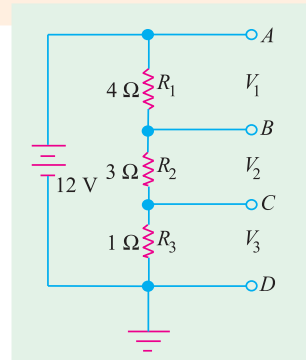

Fig. 1.90

Example 1.52. What are the output voltages of the unloaded voltage divider shown in Fig. 1.91 ? What is the direction of current through AB ?

Solution. It may be remembered that both V_1 and V_2 are with respect to the ground.

$$R = 6 + 4 + 2 = 12 \Omega$$

$$\therefore V_1 = \text{drop across } R_2 = 24 \times 4/12 = +8 \text{ V}$$

$$V_2 = \text{drop across } R_3 = -24 \times 2/12 = -4 \text{ V}$$

It should be noted that point B is at negative potential with respect to the ground.

Current flows from A to B i.e. from a point at a higher potential to a point at a lower potential.

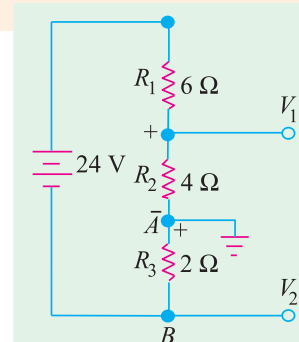

Fig. 1.91

Example 1.53. Calculate the potentials of point A, B, C and D in Fig. 1.92. What would be the new potential values if connections of 6-V battery are reversed ? All resistances are in ohm.

Solution. Since the two batteries are connected in additive series, total voltage around the circuit is $= 12 + 6 = 18 \text{ V}$. The drops across the three resistors as found by the voltage divider rule as shown in Fig. 1.92 (a) which also indicates their proper polarities. The potential of any point in the circuit can be found by starting from the ground point G (assumed to be at 0V) and going to the point either in clockwise direction or counter-clockwise direction. While going around the circuit, the rise in potential would be taken as positive and the fall in potential as negative. (Art. 2.3). Suppose we start from point G and proceed in the clockwise direction to point A. The only potential met on the way is the battery voltage which is taken as positive because there is a rise of potential since we are going from its negative to positive terminal. Hence, $V_A = +12 \text{ V}$.

$$V_B = 12 - 3 = 9 \text{ V}; V_C = 12 - 3 - 6 = 3 \text{ V}$$

Similarly, $V_D = 12 - 3 - 6 - 9 = -6 \text{ V}$.

It is also obvious that point D must be at -6 V because it is directly connected to the negative terminal of the 6-V battery.

We would also find the potentials of various points by starting from point G and going in the counter-clockwise direction. For example, $V_B = -6 + 9 + 6 = 9 \text{ V}$ as before.

The connections of the 6-V battery have been reversed in Fig. 1.92 (b). Now, the net voltage around the circuit is $12 - 6 = 6 \text{ V}$. The drop over the $1 \text{ } \Omega$ resistor is $= 6 \times 1/(1 + 2 + 3) = 1 \text{ V}$; Drop over $2 \text{ } \Omega$ resistor is $= 6 \times 2/6 = 2 \text{ V}$. Obviously, $V_A = +12 \text{ V}$, $V_B = 12 - 1 = 11 \text{ V}$, $V_C = 12 - 1 - 2 = 9 \text{ V}$. Similarly, $V_D = 12 - 1 - 2 - 3 = +6 \text{ V}$.

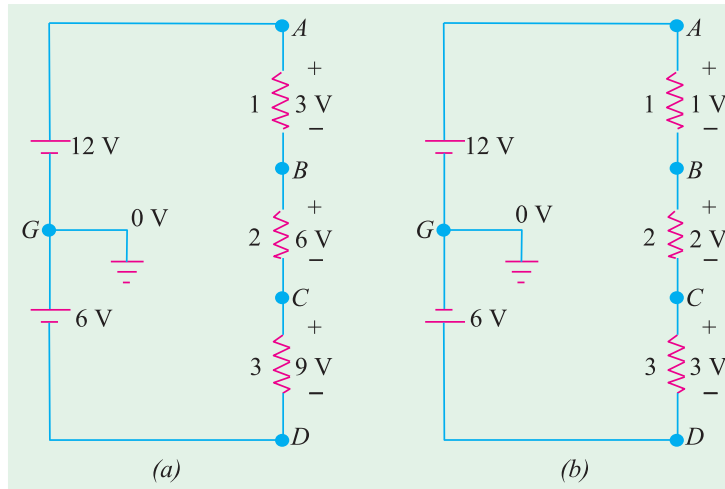

Fig. 1.92

Example 1.54. Using minimum number of components, design a voltage divider which can deliver 1 W at 100 V , 2 W at -50 V and 1.6 W at -80 V . The voltage source has an internal resistance of $200 \text{ } \Omega$ and supplies a current of 100 mA . What is the open-circuit voltage of the voltage source? All resistances are in ohm.

Solution. From the given load conditions, the load currents are as follows:

$$I_{L1} = 1/100 = 10 \text{ mA},$$

$$I_{L2} = 2/50 = 40 \text{ mA},$$

$$I_{L3} = 1.6/80 = 20 \text{ mA}$$

For economising the number of components, the internal resistance of $200 \text{ } \Omega$ can be used as the series dropping resistance. The suitable circuit and the ground connection are shown in Fig. 1.93.

Applying Kirchoff's laws to the closed circuit $ABCD$, we have

$$V - 200 \times 100 \times 10^{-3} - 100 - 80 = 0 \quad \text{or} \quad V = 200 \text{ V}$$

$$I_1 = 100 - 10 = 90 \text{ mA} \quad \therefore R_1 = 100 \text{ V}/90 \text{ mA} = 1.11 \text{ k}\Omega$$

$$I_3 = 100 - 20 = 80 \text{ mA}; \text{ voltage drop across } R_3 = -50 - (-80) = 30 \text{ V}$$

$$\therefore R_3 = 30 \text{ V}/80 \text{ mA} = 375 \text{ } \Omega$$

$$I_2 + 40 = 80 \quad \therefore I_2 = 40 \text{ mA}; R_2 = 50 \text{ V}/40 \text{ mA} = 1.25 \text{ k}\Omega$$

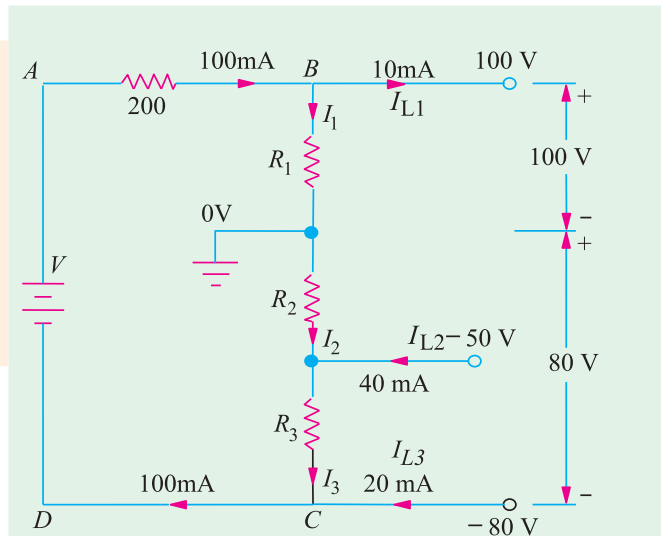

Fig. 1.93

Example 1.55. Fig. 1.94 shows a transistor with proper voltages established across its base, collector and emitter for proper function. Assume that there is a voltage drop V_{BE} across the base-emitter junction of 0.6 V and collector current I_C is equal to collector current I_E . Calculate (a) V_1 (b) V_2 and V_B (c) V_4 and V_E (d) I_E and I_C (e) V_3 (f) V_C (g) V_{CE} . All resistances are given in kilo-ohm.

Solution. (a) The 250 k and 50 k resistors form a voltage-divider bias network across 20 V supply.

$$\therefore V_1 = 20 \times \frac{250}{300} = 16.7 \text{ V}$$

$$(b) V_2 = 20 - 16.7 = 3.3 \text{ V}$$

The voltage of point B with respect to ground is $V_2 = 3.3 \text{ V}$

$$(c) V_E = V_2 - V_{BE} = 3.3 - 0.6 = 2.7 \text{ V. Also } V_4 = 2.7 \text{ V}$$

$$(d) I_E = V_4 / 2 = 2.7 \text{ V} / 2 \text{ k} = 1.35 \text{ mA. It also equals } I_C.$$

$$(e) V_3 = \text{drop across collector resistor} = 1.35 \text{ mA} \times 8 \text{ k} = 10.8 \text{ V}$$

$$(f) \text{Potential of point C is } V_C = 20 - 10.8 = 9.2 \text{ V}$$

$$(g) V_{CE} = V_C - V_E = 9.2 - 2.7 = 6.5 \text{ V}$$

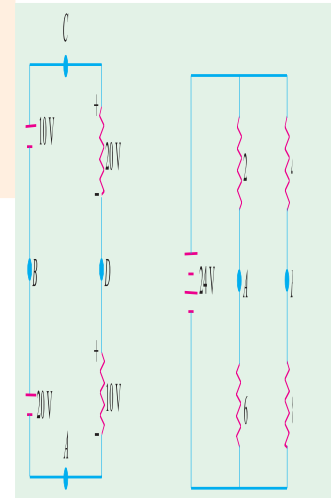

Fig. 1.94

Tutorial Problems No. 1.5

- A direct-current circuit comprises two resistors, 'A' of value 25 ohms, and 'B' of unknown value, connected in parallel, together with a third resistor 'C' of value 5 ohms connected in series with the parallel group. The potential difference across C is found to be 90 V. If the total power in the circuit is 4320 W, calculate :
 - the value of resistor B,
 - the voltage applied to the ends of the whole circuit,
 - the current in each resistor.

(Mumbai University 2002) (Nagpur University, Summer 2002)
- A current of 5 A flows through a non inductive resistance connected in series with a choke coil when supplied at 250 V, 50 Hz. If voltage across resistance is 125 V and across coil is 200 V calculate :
 - impedance, resistance and reactance of coil
 - power in coil
 - total power consumed in the circuit
 - draw phasor diagram.

(Pune University 2002) (Nagpur University, Winter 2003)
- Define temp. coefficient of resistance.

$$\text{Prove } \alpha_{t_1} = \frac{\alpha_0}{(1 + \alpha_0 t_1)}$$

where α_0 = temp. coeff. of resistance at 0°C .

(Gujrat University, Summer 2003)

- A resistance wire 10 m long and cross section area 10 mm^2 at 0°C passes a current of 10 A, when connected to a d.c. supply of 200 volts. Calculate :
 - resistivity of the material
 - current which will flow through the wire when the temp. rises to 50°C . Given $\alpha_0 = 0.0003 \text{ per } ^\circ\text{C}$.

(Mumbai University, 2003) (Gujrat University, Summer 2003)
- Why domestic appliances are connected in parallel? Give comparison with series ckt.

(B.P.T.U., Orissa 2003) (Gujrat University, Summer 2003)
- Two wires A and B made up of same material, wire B has twice the length of wire A and having half the diameter to that of A. Calculate the ratio R_B/R_A .

(Gujrat University, Summer 2003)
- A resistor of 12Ω is connected in series with a combination of 15Ω and 20Ω resistor in parallel. When a voltage of 120 V is applied across the whole circuit find the current taken from the supply.

(V.T.U., Belgaum, Karnataka University, Summer 2002)

8. A network is arranged as shown in Fig. 1.95. Determine the value of currents in each resistor.

(V.T.U., Belgaum, Karnataka University, Summer 2002)

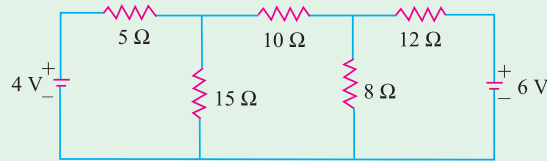

Fig. 1.95

9. A resistance of 100Ω is connected in series with $100\mu\text{F}$ capacitor across 200V, 60Hz supply. Find the impedance, current and power factor.
10. An EMF whose instantaneous value is $100\sin(314t - \pi/4)$ volts is applied to a circuit and the current flowing through it is $20\sin(314t - 1.5708)$ Amperes. Find the frequency and the values of circuit elements, assuming a series combination of circuit elements.
11. An inductive coil draws a current of 2A, when connected to a 230V, 50Hz supply. The power taken by the coil is 100 watts. Calculate the resistance and inductance of the coil.
12. Find the resistance between the terminals A and B for the network shown in Fig.1.96.

(Pune University, 2003) (V.T.U.,Belgaum University, Winter 2003)

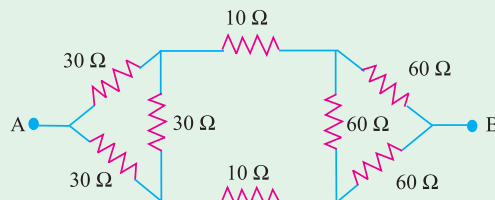

Fig. 1.96

13. A network is arranged as shown in Fig 1.97 Determine the current in each resistanc using loop current method.

(V.T.U., Belgaum, Karnataka University, Winter 2003)

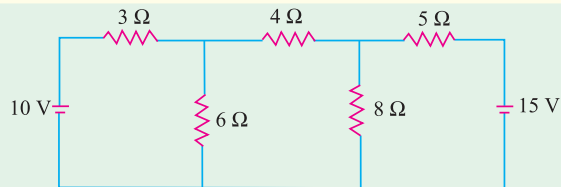

Fig. 1.97

14. A resistor of 12Ω is connected in series with a combination of 15Ω and 20Ω resistor in parallel. When a voltage of 120V is applied across the whole circuit. Find the current taken from the supply.
15. Four wires a,b,c and d are connected at a common point. The currents flowing in a,b and c towards

(V.T.U., Belgaum, Karnataka University, Winter 2004)

$$\text{the common point are } i_a = 6\sin\left(\omega t + \frac{\pi}{3}\right), i_b = 5\cos\left(\omega t + \frac{\pi}{3}\right) \text{ and } i_c = 3\cos\left(\omega t + \frac{2\pi}{3}\right).$$

Determine the current in the fourth wire. (V.T.U., Belgaum, Karnataka University, Winter 2004)

16. Two resistors $R_1 = 2500\Omega$ and $R_2 = 4000\Omega$ are in series across a 100V supply. The voltage drop across R_1 and R_2 are successively measured by a voltmeter having a resistance of $50,000\Omega$ Find the sum of the two readings.

(V.T.U., Belgaum, Karnataka University, Winter 2004)

17. Explain 'resistance', 'reactance' and 'impedance'. (RGPV, Bhopal December 2002)
18. A 4 ohm resistor is connected to a 10 mH inductor across a 100 V, 50 Hz voltage source. Find input current, voltage drops across resistor and inductor, power factor of the circuit and the real power consumed in the circuit. (Mumbai University 2002) (RGPV, Bhopal December 2003)
19. Define and explain the terms MMF, Reluctance, Permeance, flux density and fringing. (RGPV, Bhopal December 2003)
20. Find the value of resistance (R), if source current is 6 amp and source voltage is 66 V is shown in Fig.1.98 (Pune University 2003) (Nagpur University, Winter 2002)

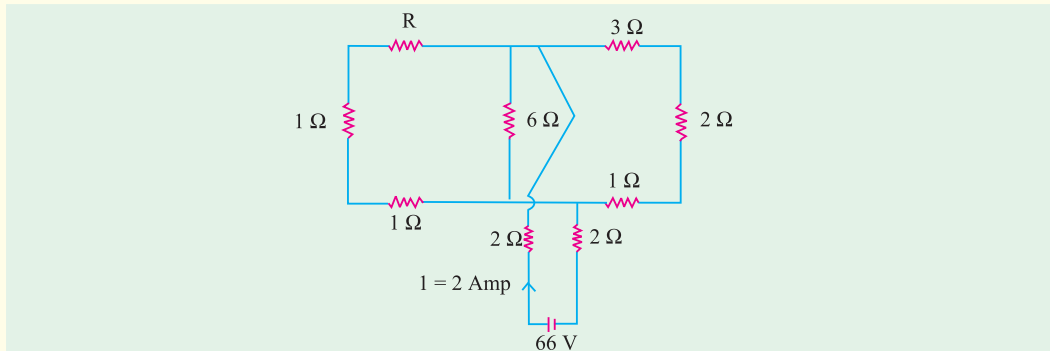

Fig. 1.98

21. Determine a non-negative value of R such that the power consumed by the 2-Ω resistor in the Fig.1.99 is shown maximum. (Pune University 2003)(Engineering Services Examination 2003)

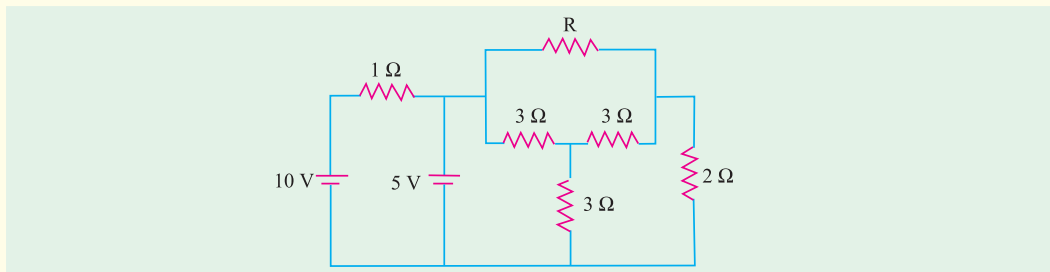

Fig. 1.99

OBJECTIVE TESTS –1

- A 100 μA ammeter has an internal resistance of 100 Ω . For extending its range to measure 500 μA , the shunt required is of resistance (in Ω)
 (a) 20.0 (b) 22.22
 (c) 25.0 (d) 50.0
 (GATE 2001)
- Resistances R_1 and R_2 have, respectively, nominal values of 10 Ω and 5 Ω , and tolerances of $\pm 5\%$ and $\pm 10\%$. The range of values for the parallel combination of R_1 and R_2 is
 (a) 3.077 Ω to 3.636 Ω
 (b) 2.805 Ω to 3.371 Ω
 (c) 3.237 Ω to 3.678 Ω
 (d) 3.192 Ω to 3.435 Ω
 (GATE 2001)
- The open circuit impedance of a certain length of a loss-less line is 100 Ω . The short circuit impedance of the same line is also 100 Ω . The characteristic impedance of the line is
 (a) 100 $\sqrt{2}$ Ω (b) 50 Ω
 (c) $\frac{100}{\sqrt{2}}$ Ω (d) 100 Ω
 (ESE 2001)
- The current in the given circuit with a dependent voltage source is
 (a) 10A (b) 12 A
 (c) 14 A (d) 16 A
 (ESE 2001)

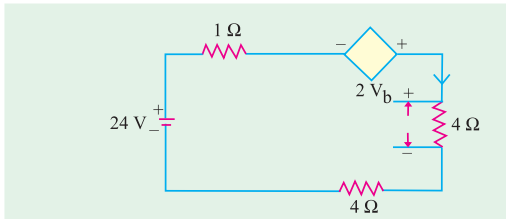

Fig. 1.100

5. The value of resistance 'R' shown in the given Fig. 1.101 is

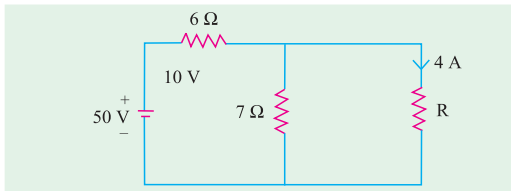

Fig. 1.101

- (a) 3.5 Ω (b) 2.5 Ω
(c) 1 Ω (d) 4.5 Ω

(ESE 2001)

6. For the circuit shown in the given Fig. 1.102 the current I is given by

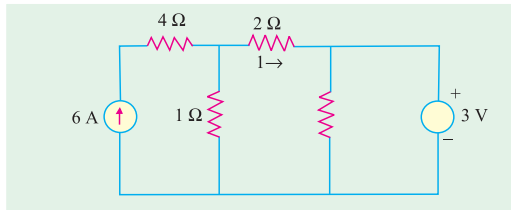

Fig. 1.102

- (a) 3 A (b) 2 A
(c) 1 A (d) zero

(Pune University 2003) (ESE 2001)

7. The value of V in the circuit shown in the given Fig. 1.103 is

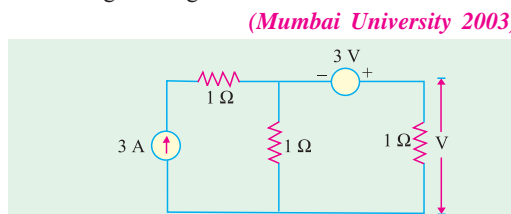

Fig. 1.103

- (a) 1 V (b) 2 V
(c) 3 V (d) 4 V

(GATE 2003) (ESE 2001)

8. In the circuit shown in Fig. 1.104, the value of V_s is 0, when $I = 4A$. The value of I when $V_s = 16V$, is

- (a) 6 A (b) 8 A
(c) 10 A (d) 12 A

(GATE 2003) (ESE 2003)

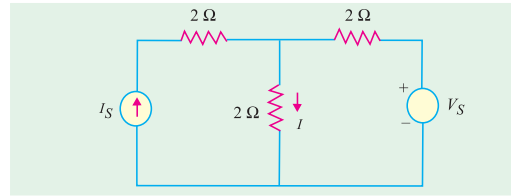

Fig. 1.104

9. The linear network as in Fig. 1.105 has only resistors. If $I_1 = 8A$ and $I_2 = 12A$; V is found to be 80 V. $V = 0$ when $I_1 = -8A$ and $I_2 = 4A$. Then the value of V when $I_1 = I_2 = 10A$, is

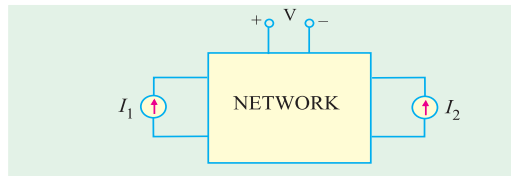

Fig. 1.105

- (a) 25 V (b) 50
(c) 75 V (d) 100 V

(GATE 2003) (ESE 2003)

10. In Fig. 1.106, the value of R is

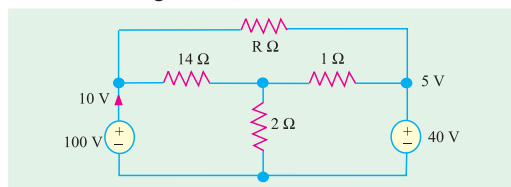

Fig. 1.106

- (a) 10 Ω (b) 18 Ω
(c) 24 Ω (d) 12 Ω

(GATE 2003)

11. In the circuit shown in Fig. 1.107, the switch S is closed at time $t = 0$. The voltage across the inductance at $t = 0^+$, is

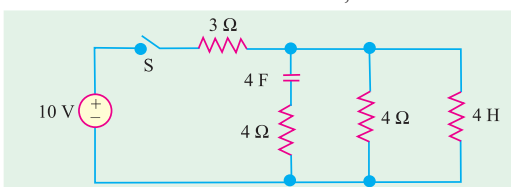

Fig. 1.107

- (a) 2 V (b) 4 V
(c) -6 V (d) 8 V

(GATE 2003)

12. The rms value of the resultant current in a wire which carries a dc current of 10 A and a sinusoidal alternating current of peak value 20 A is

- (a) 14.1 A (b) 17.3 A
(c) 22.4 A (d) 30.0 A

(GATE 2004)