

C H A P T E R 2

Learning Objectives

- Electric Circuits and Network Theorems
- Kirchhoff's Laws
- Determination of Voltage Sign
- Assumed Direction of Current
- Solving Simultaneous Equations
- Determinants
- Solving Equations with Two Unknowns
- Solving Equations With Three Unknowns
- Independent and Dependent Sources
- Maxwell's Loop Current Method
- Mesh Analysis Using Matrix Form
- Nodal Analysis with Voltage Sources
- Nodal Analysis with Current Sources
- Source Conversion
- Ideal Constant-Voltage Source
- Ideal Constant-Current Source
- Superposition Theorem
- Thevenin Theorem
- How to Thevenize a Given Circuit ?
- General Instructions for Finding Thevenin Equivalent Circuit
- Reciprocity Theorem
- Delta/Star Transformation
- Star/Delta Transformation
- Compensation Theorem
- Norton's Theorem
- How to Nortanize a Given Circuit ?
- General Instructions for Finding Norton Equivalent Circuit
- Millman's Theorem
- Generalised Form of Millman's Theorem
- Maximum Power Transfer Theorem
- Power Transfer Efficiency

DC NETWORK THEOREMS

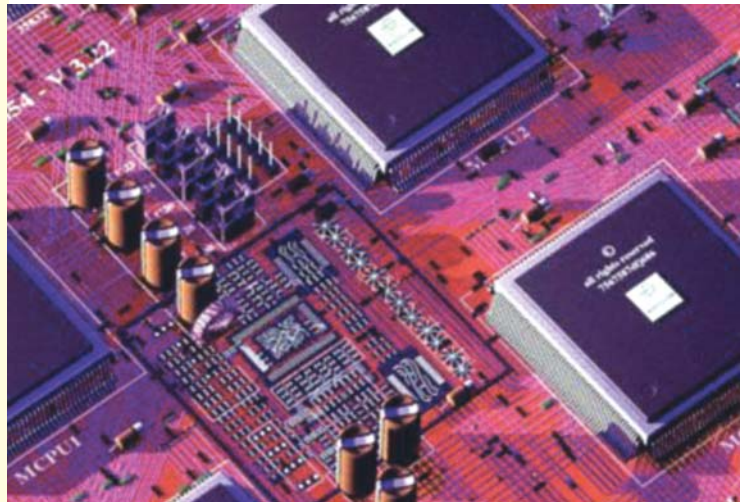

↑ Network theorems help to determine the unknown values of current, resistance and voltage etc, in electric networks

2.1. Electric Circuits and Network Theorems

There are certain theorems, which when applied to the solutions of electric networks, wither simplify the network itself or render their analytical solution very easy. These theorems can also be applied to an a.c. system, with the only difference that impedances replace the ohmic resistance of d.c. system. Different electric circuits (according to their properties) are defined below :

1. **Circuit.** A circuit is a closed conducting path through which an electric current either flows or is intended flow.
2. **Parameters.** The various elements of an electric circuit are called its parameters like resistance, inductance and capacitance. These parameters may be *lumped or distributed*.
3. **Liner Circuit.** A linear circuit is one whose parameters are constant *i.e.* they do not change with voltage or current.
4. **Non-linear Circuit.** It is that circuit whose parameters change with voltage or current.
5. **Bilateral Circuit.** A bilateral circuit is one whose properties or characteristics are the same in either direction. The usual transmission line is bilateral, because it can be made to perform its function equally well in either direction.
6. **Unilateral Circuit.** It is that circuit whose properties or characteristics change with the direction of its operation. A diode rectifier is a unilateral circuit, because it cannot perform rectification in both directions.
7. **Electric Network.** A combination of various electric elements, connected in any manner whatsoever, is called an electric network.
8. **Passive Network** is one which contains no source of e.m.f. in it.
9. **Active Network** is one which contains one or more than one source of e.m.f.
10. **Node** is a junction in a circuit where two or more circuit elements are connected together.
11. **Branch** is that part of a network which lies between two junctions.
12. **Loop.** It is a close path in a circuit in which no element or node is encountered more than once.
13. **Mesh.** It is a loop that contains no other loop within it. For example, the circuit of Fig. 2.1 (a) has even branches, six nodes, three loops and two meshes whereas the circuit of Fig. 2.1 (b) has four branches, two nodes, six loops and three meshes.

It should be noted that, unless stated otherwise, an electric network would be assumed passive in the following treatment.

We will now discuss the various network theorems which are of great help in solving complicated networks. Incidentally, a network is said to be completely

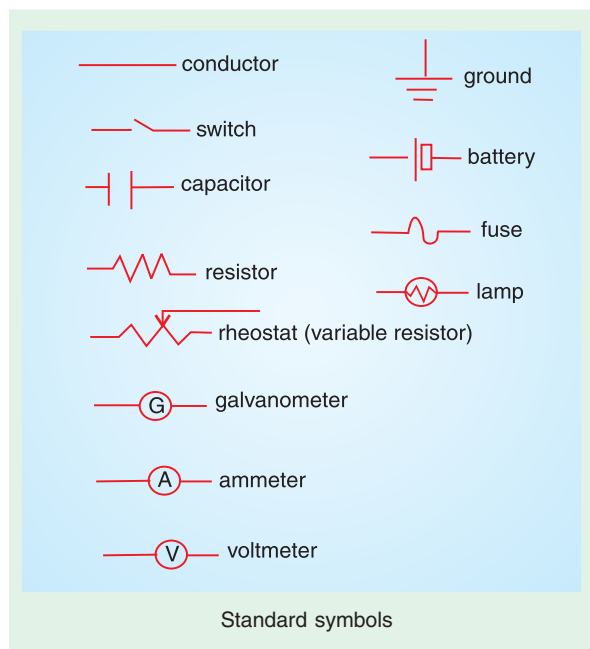

solved or analyzed when all voltages and all currents in its different elements are determined.

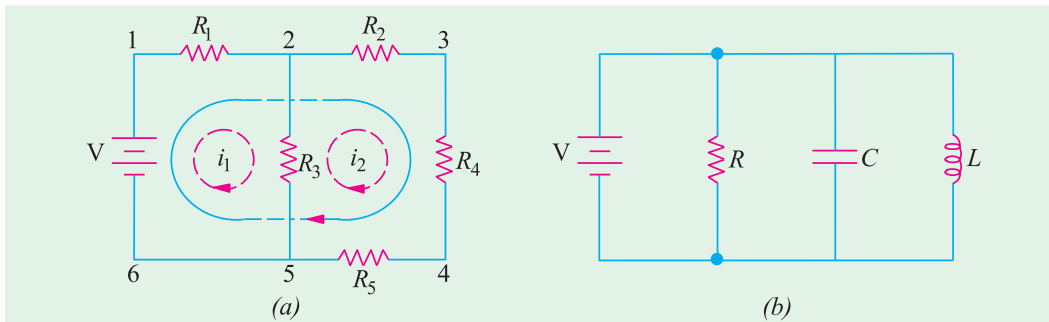

Fig. 2.1

There are two general approaches to network analysis :

(i) Direct Method

Here, the network is left in its original form while determining its different voltages and currents. Such methods are usually restricted to fairly simple circuits and include Kirchhoff's laws, Loop analysis, Nodal analysis, superposition theorem, Compensation theorem and Reciprocity theorem etc.

(ii) Network Reduction Method

Here, the original network is converted into a much simpler equivalent circuit for rapid calculation of different quantities. This method can be applied to simple as well as complicated networks. Examples of this method are : Delta/Star and Star/Delta conversions. Thevenin's theorem and Norton's Theorem etc.

2.2. Kirchhoff's Laws *

These laws are more comprehensive than Ohm's law and are used for solving electrical networks which may not be readily solved by the latter. Kirchhoff's laws, two in number, are particularly useful **(a)** in determining the equivalent resistance of a complicated network of conductors and **(b)** for calculating the currents flowing in the various conductors. The two-laws are :

1. Kirchhoff's Point Law or Current Law (KCL)

It states as follows :

in any electrical network, the algebraic sum of the currents meeting at a point (or junction) is zero.

Put in another way, it simply means that the total current *leaving* a junction is equal to the total current *entering* that junction. It is obviously true because there is no accumulation of charge at the junction of the network.

Consider the case of a few conductors meeting at a point A as in Fig. 2.2 (a). Some conductors have currents leading to point A, whereas some have currents leading away from point A. Assuming the incoming currents to be positive and the outgoing currents negative, we have

$$I_1 + (-I_2) + (-I_3) + (+I_4) + (-I_5) = 0$$

or
$$I_1 + I_4 - I_2 - I_3 - I_5 = 0 \quad \text{or} \quad I_1 + I_4 = I_2 + I_3 + I_5$$

or **incoming currents = outgoing currents**

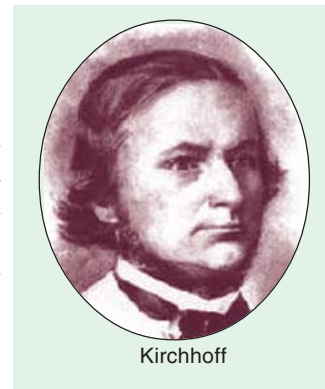

Kirchhoff

* After Gustave Robert Kirchhoff (1824-1887), an outstanding German Physicist.

Similarly, in Fig. 2.2 (b) for node A

$$+ I + (-I_1) + (-I_2) + (-I_3) + (-I_4) = 0 \quad \text{or} \quad I = I_1 + I_2 + I_3 + I_4$$

We can express the above conclusion thus : $\Sigma I = 0$...at a junction

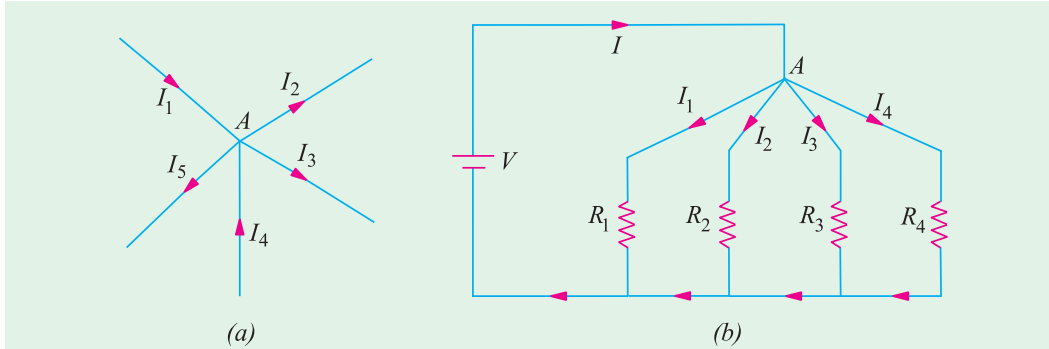

Fig. 2.2

2. Kirchhoff's Mesh Law or Voltage Law (KVL)

It states as follows :

The algebraic sum of the products of currents and resistances in each of the conductors in any closed path (or mesh) in a network plus the algebraic sum of the e.m.fs. in that path is zero.

In other words, $\Sigma IR + \Sigma e.m.f. = 0$...round a mesh

It should be noted that algebraic sum is the sum which takes into account the polarities of the voltage drops.

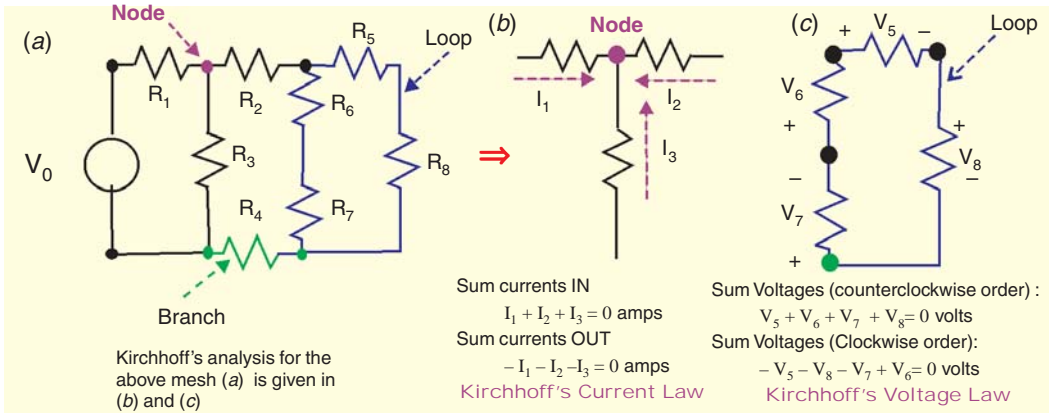

The basis of this law is this : If we start from a particular junction and go round the mesh till we come back to the starting point, then we must be at the same potential with which we started. Hence, it means that all the sources of e.m.f. met on the way must necessarily be equal to the voltage drops in the resistances, every voltage being given its proper sign, plus or minus.

2.3. Determination of Voltage Sign

In applying Kirchhoff's laws to specific problems, particular attention should be paid to the algebraic signs of voltage drops and e.m.fs., otherwise results will come out to be wrong. Following sign conventions is suggested :

(a) Sign of Battery E.M.F.

A rise in voltage should be given a + ve sign and a fall in voltage a -ve sign. Keeping this in

mind, it is clear that as we go from the $-ve$ terminal of a battery to its $+ve$ terminal (Fig. 2.3), there is a *rise* in potential, hence this voltage should be given a $+ve$ sign. If, on the other hand, we go from $+ve$ terminal to $-ve$ terminal, then there is a *fall* in potential, hence this voltage should be preceded

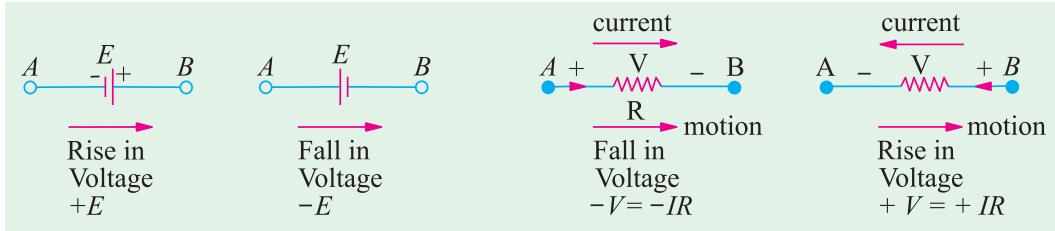

Fig. 2.3

Fig. 2.4

by a $-ve$ sign. ***It is important to note that the sign of the battery e.m.f. is independent of the direction of the current through that branch.***

(b) Sign of IR Drop

Now, take the case of a resistor (Fig. 2.4). If we go through a resistor in the *same* direction as the current, then there is a *fall* in potential because current flows from a higher to a lower potential. Hence, this voltage fall should be taken $-ve$. However, if we go in a direction opposite to that of the current, then there is a *rise* in voltage. Hence, this voltage rise should be given a positive sign.

It is clear that the sign of voltage drop across a resistor depends on the direction of current through that resistor but is independent of the polarity of any other source of e.m.f. in the circuit under consideration.

Consider the closed path ABCDA in Fig. 2.5. As we travel around the mesh in the clockwise direction, different voltage drops will have the following signs :

I_1R_1	is $-ve$	(fall in potential)
I_2R_2	is $-ve$	(fall in potential)
I_3R_3	is $+ve$	(rise in potential)
I_4R_4	is $-ve$	(fall in potential)
E_2	is $-ve$	(fall in potential)
E_1	is $+ve$	(rise in potential)

Using Kirchhoff's voltage law, we get

$$-I_1R_1 - I_2R_2 - I_3R_3 - I_4R_4 - E_2 + E_1 = 0$$

$$\text{or } I_1R_1 + I_2R_2 - I_3R_3 + I_4R_4 = E_1 - E_2$$

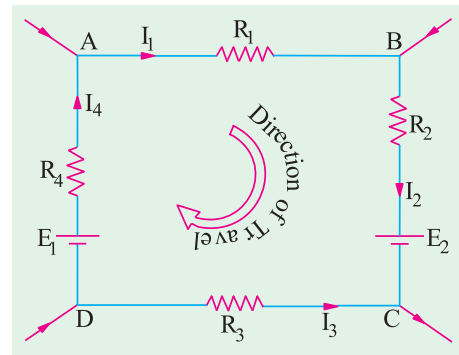

Fig. 2.5

2.4. Assumed Direction of Current

In applying Kirchhoff's laws to electrical networks, the question of assuming proper direction of current usually arises. The direction of current flow may be assumed either clockwise or anticlockwise. If the assumed direction of current is not the actual direction, then on solving the question, this current will be found to have a minus sign. If the answer is positive, then assumed direction is the same as actual direction (Example 2.10). ***However, the important point is that once a particular direction has been assumed, the same should be used throughout the solution of the question.***

Note. It should be noted that Kirchhoff's laws are applicable both to d.c. and a.c. voltages and currents. However, in the case of alternating currents and voltages, any e.m.f. of self-inductance or that existing across a capacitor should be also taken into account (See Example 2.14).

2.5. Solving Simultaneous Equations

Electric circuit analysis with the help of Kirchhoff's laws usually involves solution of two or three simultaneous equations. These equations can be solved by a systematic elimination of the variables but the procedure is often lengthy and laborious and hence more liable to error. Determinants and Cramer's rule provide a simple and straight method for solving network equations through manipulation of their coefficients. Of course, if the number of simultaneous equations happens to be very large, use of a digital computer can make the task easy.

2.6. Determinants

The symbol $\begin{vmatrix} a & b \\ c & d \end{vmatrix}$ is called a determinant of the second order (or 2×2 determinant) because it contains two rows (ab and cd) and two columns (ac and bd). The numbers a , b , c and d are called the elements or constituents of the determinant. Their number in the present case is $2^2 = 4$.

The evaluation of such a determinant is accomplished by cross-multiplication is illustrated below :

$$\Delta = \begin{vmatrix} a & b \\ c & d \end{vmatrix} = ad - bc$$

The above result for a second order determinant can be remembered as

upper left times lower right minus upper right times lower left

The symbol $\begin{vmatrix} a_1 & b_1 & c_1 \\ a_2 & b_2 & c_2 \\ a_3 & b_3 & c_3 \end{vmatrix}$ represents a third-order determinant having $3^2 = 9$ elements. It may be evaluated (or expanded) as under :

1. Multiply each element of the first row (or alternatively, first column) by a determinant obtained by omitting the row and column in which it occurs. (It is called minor determinant or just minor as shown in Fig. 2.6).

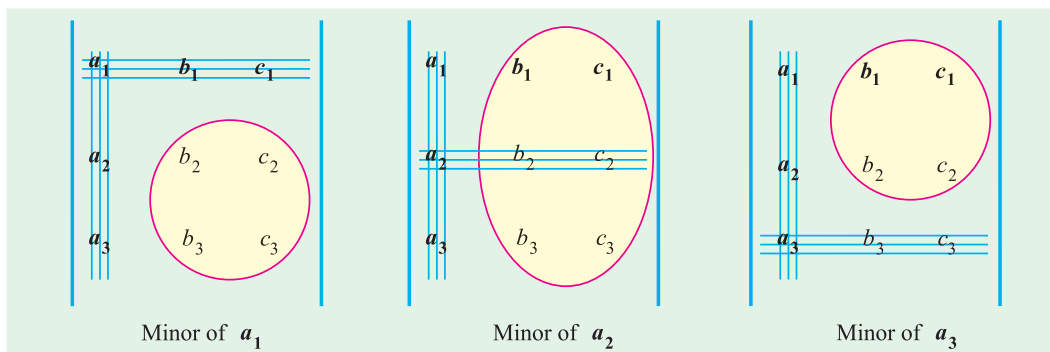

Fig. 2.6

2. Prefix + and -ing alternately to the terms so obtained.
3. Add up all these terms together to get the value of the given determinant.

Considering the first column, minors of various elements are as shown in Fig. 2.6.

Expanding in terms of first column, we get

$$\begin{aligned} \Delta &= a_1 \begin{vmatrix} b_2 & c_2 \\ b_3 & c_3 \end{vmatrix} - a_2 \begin{vmatrix} b_1 & c_1 \\ b_3 & c_3 \end{vmatrix} + a_3 \begin{vmatrix} b_1 & c_1 \\ b_2 & c_2 \end{vmatrix} \\ &= a_1 (b_2c_3 - b_3c_2) - a_2 (b_1c_3 - b_3c_1) + a_3 (b_1c_2 - b_2c_1) \quad \dots(i) \end{aligned}$$

Expanding in terms of the first row, we get

$$\begin{aligned}\Delta &= a_1 \begin{vmatrix} b_2 & c_2 \\ b_3 & c_3 \end{vmatrix} - b_1 \begin{vmatrix} a_2 & c_2 \\ a_3 & c_3 \end{vmatrix} + c_1 \begin{vmatrix} a_2 & b_2 \\ a_3 & b_3 \end{vmatrix} \\ &= a_1 (b_2 c_3 - b_3 c_2) - b_1 (a_2 c_3 - a_3 c_2) + c_1 (a_2 b_3 - a_3 b_2)\end{aligned}$$

which will be found to be the same as above.

Example 2.1. Evaluate the determinant $\begin{vmatrix} 7 & -3 & -4 \\ -3 & 6 & -2 \\ -4 & -2 & 11 \end{vmatrix}$

Solution. We will expand with the help of 1st column.

$$\begin{aligned}D &= 7 \begin{vmatrix} -2 & -2 \\ -4 & 11 \end{vmatrix} - (-3) \begin{vmatrix} -3 & -4 \\ -4 & 11 \end{vmatrix} + (-4) \begin{vmatrix} -3 & -4 \\ 6 & -2 \end{vmatrix} \\ &= 7 [(6 \times 11) - (-2 \times -2)] + 3 [(-3 \times 11) - (-4 \times -2)] - 4 [(-3 \times -2) - (-4 \times 6)] \\ &= 7 (66 - 4) + 3 (-33 - 8) - 4 (6 + 24) = \mathbf{191}\end{aligned}$$

2.7. Solving Equations with Two Unknowns

Suppose the two given simultaneous equations are

$$\begin{aligned}ax + by &= c \\ dx + ey &= f\end{aligned}$$

Here, the two unknown are x and y , a, b, d and e are coefficients of these unknowns whereas c and f are constants. The procedure for solving these equations by the method of determinants is as follows :

- Write the two equations in the matrix form as $\begin{bmatrix} a & b \\ d & e \end{bmatrix} \begin{bmatrix} x \\ y \end{bmatrix} = \begin{bmatrix} c \\ f \end{bmatrix}$
- The **common** determinant is given as $\Delta = \begin{vmatrix} a & b \\ d & e \end{vmatrix} = ae - bd$
- For finding the determinant for x , replace the coefficients of x in the original matrix by the constants so that we get determinant Δ_1 given by $\Delta_1 = \begin{vmatrix} c & b \\ f & e \end{vmatrix} = (ce - bf)$
- For finding the determinant for y , replace coefficients of y by the constants so that we get $\Delta_2 = \begin{vmatrix} a & c \\ d & f \end{vmatrix} = (af - cd)$
- Apply Cramer's rule to get the value of x and y
 $x = \frac{\Delta_1}{\Delta} = \frac{ce - bf}{ae - bd}$ and $y = \frac{\Delta_2}{\Delta} = \frac{af - cd}{ae - bd}$

Example 2.2. Solve the following two simultaneous equations by the method of determinants :

$$\begin{aligned}4i_1 - 3i_2 &= 1 \\ 3i_1 - 5i_2 &= 2\end{aligned}$$

Solution. The matrix form of the equations is $\begin{bmatrix} 4 & -3 \\ 3 & -5 \end{bmatrix} \begin{bmatrix} i_1 \\ i_2 \end{bmatrix} = \begin{bmatrix} 1 \\ 2 \end{bmatrix}$

$$\begin{aligned}\Delta &= \begin{vmatrix} 4 & -3 \\ 3 & -5 \end{vmatrix} = (4 \times -5) - (-3 \times 3) = -11 \\ \Delta_1 &= \begin{vmatrix} 1 & -3 \\ 2 & -5 \end{vmatrix} = (1 \times -5) - (-3 \times 2) = 1 \\ \Delta_2 &= \begin{vmatrix} 4 & 1 \\ 3 & 2 \end{vmatrix} = (4 \times 2) - (1 \times 3) = 5\end{aligned}$$

$$\therefore i_1 = \frac{\Delta_1}{\Delta} = \frac{1}{-11} = -\frac{1}{11}; \quad i_2 = \frac{\Delta_2}{\Delta} = -\frac{5}{11}$$

2.8. Solving Equations With Three Unknowns

Let the three simultaneous equations be as under :

$$\begin{aligned} ax + by + cz &= d \\ ex + fy + gz &= h \\ jx + ky + lz &= m \end{aligned}$$

The above equations can be put in the matrix form as under :

$$\begin{bmatrix} a & b & c \\ e & f & g \\ j & k & l \end{bmatrix} \begin{bmatrix} x \\ y \\ z \end{bmatrix} = \begin{bmatrix} d \\ h \\ m \end{bmatrix}$$

The value of common determinant is given by

$$\Delta = \begin{vmatrix} a & b & c \\ e & f & g \\ j & k & l \end{vmatrix} = a(fl - gk) - e(bl - ck) + j(bg - cf)$$

The determinant for x can be found by replacing coefficients of x in the original matrix by the constants.

$$\therefore \Delta_1 = \begin{vmatrix} d & b & c \\ h & f & g \\ m & k & l \end{vmatrix} = d(fl - gk) - h(bl - ck) + m(bg - cf)$$

Similarly, determinant for y is given by replacing coefficients of y with the three constants.

$$\Delta_2 = \begin{vmatrix} a & d & c \\ e & h & g \\ j & m & l \end{vmatrix} = a(hl - mg) - e(dl - mc) + j(dg - hc)$$

In the same way, determinant for z is given by

$$\Delta_3 = \begin{vmatrix} a & b & d \\ e & f & h \\ j & k & m \end{vmatrix} = a(fm - hk) - e(bm - dk) + j(bh - df)$$

As per Cramer's rule $x = \frac{\Delta_1}{\Delta}, y = \frac{\Delta_2}{\Delta}, z = \frac{\Delta_3}{\Delta}$

Example 2.3. Solve the following three simultaneous equations by the use of determinants and Cramer's rule

$$\begin{aligned} i_1 + 3i_2 + 4i_3 &= 14 \\ i_1 + 2i_2 + i_3 &= 7 \\ 2i_1 + i_2 + 2i_3 &= 2 \end{aligned}$$

Solution. As explained earlier, the above equations can be written in the form

$$\begin{bmatrix} 1 & 3 & 4 \\ 1 & 2 & 1 \\ 2 & 1 & 2 \end{bmatrix} \begin{bmatrix} i_1 \\ i_2 \\ i_3 \end{bmatrix} = \begin{bmatrix} 14 \\ 7 \\ 2 \end{bmatrix}$$

$$\Delta = \begin{vmatrix} 1 & 3 & 4 \\ 1 & 2 & 1 \\ 2 & 1 & 2 \end{vmatrix} = 1(4 - 1) - 1(6 - 4) + (3 - 8) = -9$$

$$\Delta_1 = \begin{vmatrix} 14 & 3 & 4 \\ 7 & 2 & 1 \\ 2 & 1 & 2 \end{vmatrix} = 14(4 - 1) - 7(6 - 4) + 2(3 - 8) = 18$$

$$\Delta_2 = \begin{bmatrix} 1 & 14 & 4 \\ 1 & 7 & 1 \\ 2 & 2 & 2 \end{bmatrix} = 1(14 - 2) - 1(28 - 8) + 2(14 - 28) = -36$$

$$\Delta_3 = \begin{bmatrix} 1 & 3 & 14 \\ 1 & 2 & 7 \\ 2 & 1 & 2 \end{bmatrix} = 1(4 - 7) - 1(6 - 14) + 2(21 - 28) = -9$$

According to Cramer's rule,

$$i_1 = \frac{-1}{9} = -\frac{1}{9} \text{ A}; \quad i_2 = \frac{-2}{9} = -\frac{2}{9} \text{ A}; \quad i_3 = \frac{-3}{9} = -\frac{1}{3} \text{ A}$$

Example 2.4. What is the voltage V_s across the open switch in the circuit of Fig. 2.7?

Solution. We will apply KVL to find V_s . Starting from point A in the clockwise direction and using the sign convention given in Art. 2.3, we have

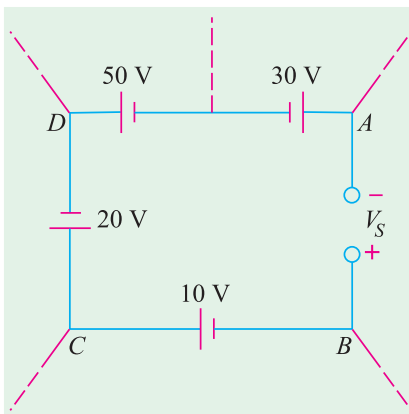

Fig. 2.7

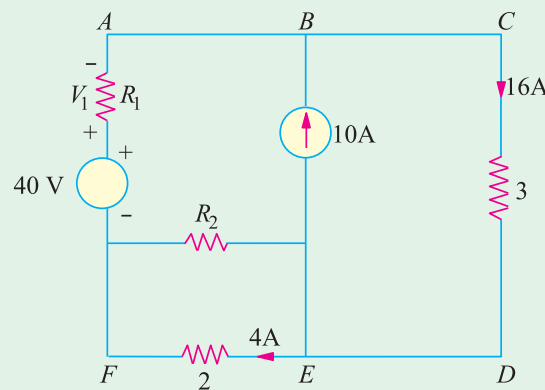

Fig. 2.8

$$+V_s + 10 - 20 - 50 + 30 = 0 \quad \therefore V_s = 30 \text{ V}$$

Example 2.5. Find the unknown voltage V_1 in the circuit of Fig. 2.8.

Solution. Initially, one may not be clear regarding the solution of this question. One may think of Kirchhoff's laws or mesh analysis etc. But a little thought will show that the question can be solved by the simple application of Kirchhoff's voltage law. Taking the outer closed loop **ABCDEF** and applying KVL to it, we get

$$-16 \times 3 - 4 \times 2 + 40 - V_1 = 0; \quad \therefore V_1 = -16 \text{ V}$$

The negative sign shows there is a fall in potential.

Example 2.6. Using Kirchhoff's Current Law and Ohm's Law, find the magnitude and polarity of voltage V in Fig. 2.9 (a). Directions of the two current sources are as shown.

Solution. Let us arbitrarily choose the directions of I_1, I_2 and I_3 and polarity of V as shown in Fig. 2.9(b). We will use the sign convention for currents as given in Art. 2.3. Applying KCL to node A, we have

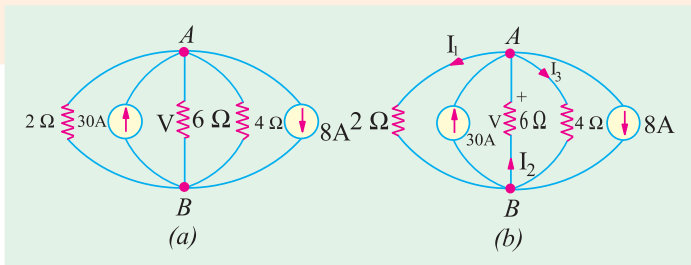

Fig. 2.9

$$-I_1 + 30 + I_2 - I_3 - 8 = 0$$

$$\text{or } I_1 - I_2 + I_3 = 22 \quad \dots(i)$$

Applying Ohm's law to the three resistive branches in Fig. 2.9 (b), we have

$$I_1 = \frac{V}{2}, I_3 = \frac{V}{4}, I_2 = -\frac{V}{6} \quad (\text{Please note the -ve sign.})$$

Substituting these values in (i) above, we get

$$\frac{V}{2} - \left(-\frac{V}{6}\right) + \frac{V}{4} = 22 \quad \text{or } V = 24 \text{ V}$$

$$\therefore I_1 = V/2 = 24/2 = 12 \text{ A}, I_2 = -24/6 = -4 \text{ A}, I_3 = 24/4 = 6 \text{ A}$$

The negative sign of I_2 indicates that actual direction of its flow is opposite to that shown in Fig. 2.9 (b). Actually, I_2 flows from A to B and not from B to A as shown.

Incidentally, it may be noted that all currents are outgoing except 30A which is an incoming current.

Example 2.7. For the circuit shown in Fig. 2.10, find V_{CE} and V_{AG} .

(F.Y. Engg. Pune Univ.)

Solution. Consider the two battery circuits of Fig. 2.10 separately. Current in the 20 V battery circuit ABCD is $20/(6 + 5 + 9) = 1\text{A}$. Similarly, current in the 40 V battery circuit EFGH is $40/(5 + 8 + 7) = 2\text{A}$. Voltage drops over different resistors can be found by using Ohm's law.

For finding V_{CE} i.e. voltage of point C with respect to point E, we will start from point E and go to C via points H and B. We will find the algebraic sum of the voltage drops met on the way from point E to C. Sign convention of the voltage drops and battery e.m.fs. would be the same as discussed in Art. 2.3.

$$\therefore V_{CE} = (-5 \times 2) + (10) - (5 \times 1) = -5\text{V}$$

The negative sign shows that point C is negative with respect to point E.

$$V_{AG} = (7 \times 2) + (10) + (6 \times 1) = 30 \text{ V.}$$

The positive sign shows that point A is at a positive potential of 30 V with respect to point G.

Example 2.8. Determine the currents in the unbalanced bridge circuit of Fig. 2.11 below. Also, determine the p.d. across BD and the resistance from B to D.

Solution. Assumed current directions are as shown in Fig. 2.11.

Applying Kirchhoff's Second Law to circuit DACD, we get

$$-x - 4z + 2y = 0 \quad \text{or } x - 2y + 4z = 0 \quad \dots(1)$$

Circuit ABCA gives

$$-2(x - z) + 3(y + z) + 4z = 0 \quad \text{or } 2x - 3y - 9z = 0 \quad \dots(2)$$

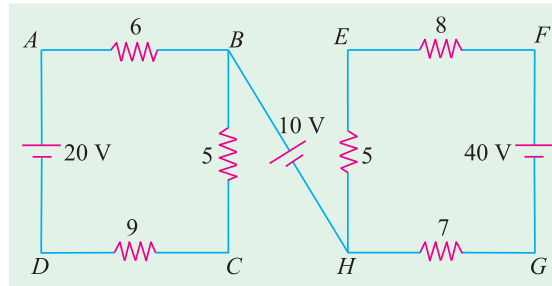

Fig. 2.10

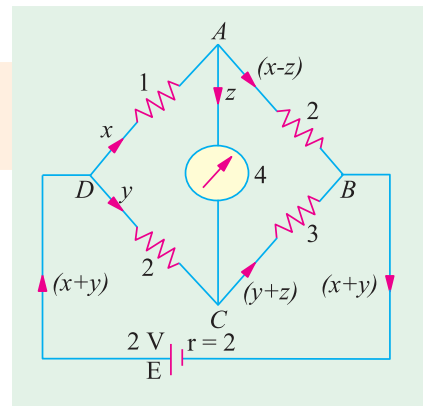

Fig. 2.11

Circuit *DABED* gives

$$-x - 2(x - z) - 2(x + y) + 2 = 0 \text{ or } 5x + 2y - 2z = 2 \quad \dots(3)$$

Multiplying (1) by 2 and subtracting (2) from it, we get

$$-y + 17z = 0 \quad \dots(4)$$

Similarly, multiplying (1) by 5 and subtracting (3) from it, we have

$$-12y + 22z = -2 \text{ or } -6y + 11z = -1 \quad \dots(5)$$

Eliminating y from (4) and (5), we have $91z = 1$ or $z = 1/91$ A

From (4); $y = 17/91$ A. Putting these values of y and z in (1), we get $x = 30/91$ A

Current in *DA* = $x = 30/91$ A Current in *DC* = $y = 17/91$ A

$$\text{Current in } AB = x - z = \frac{30}{91} - \frac{1}{91} = \frac{29}{91} \text{ A}$$

$$\text{Current in } CB = y - z = \frac{17}{91} - \frac{1}{91} = \frac{16}{91} \text{ A}$$

$$\text{Current in external circuit} = x + y = \frac{30}{91} + \frac{17}{91} = \frac{47}{91} \text{ A}$$

$$\text{Current in } AC = z = 1/91 \text{ A}$$

$$\text{Internal voltage drop in the cell} = 2(x + y) = 2 \times 47/91 = 94/91 \text{ V}$$

$$\therefore \text{P.D. across points } D \text{ and } B = 2 \times \frac{94}{91} = \frac{188}{91} \text{ V} *$$

Equivalent resistance of the bridge between points *D* and *B*

$$= \frac{\text{p.d. between points } B \text{ and } D}{\text{current between points } B \text{ and } D} = \frac{188/91}{47/91} = \frac{188}{47} = 1.87 \Omega \text{ (approx)}$$

Solution By Determinants

The matrix from the three simultaneous equations (1), (2) and (3) is

$$\begin{bmatrix} 1 & -2 & 4 \\ 2 & -3 & -9 \\ 5 & 2 & -2 \end{bmatrix} \begin{bmatrix} x \\ y \\ z \end{bmatrix} = \begin{bmatrix} 0 \\ 0 \\ 2 \end{bmatrix}$$

$$\Delta = \begin{vmatrix} 1 & -2 & 4 \\ 2 & -3 & -9 \\ 5 & 2 & -2 \end{vmatrix} = 1(6 + 18) - 2(4 - 8) + 5(18 + 12) = 182$$

$$\Delta_1 = \begin{vmatrix} 0 & -2 & 4 \\ 0 & -3 & -9 \\ 2 & 2 & -2 \end{vmatrix} = 0(6 + 18) - 0(4 - 8) + 2(18 + 12) = 60$$

$$\Delta_2 = \begin{vmatrix} 1 & 0 & 4 \\ 2 & 0 & -9 \\ 5 & 2 & -2 \end{vmatrix} = 34, \Delta_3 = \begin{vmatrix} 1 & -2 & 0 \\ 2 & -3 & 0 \\ 5 & 2 & 2 \end{vmatrix} = 2$$

$$\therefore x = \frac{-1}{182} \frac{60}{91} \text{ A}, y = \frac{34}{182} \frac{17}{91} \text{ A}, z = \frac{2}{182} \frac{1}{91} \text{ A}$$

Example 2.9. Determine the branch currents in the network of Fig. 2.12 when the value of each branch resistance is one ohm. (Elect. Technology, Allahabad Univ. 1992)

Solution. Let the current directions be as shown in Fig. 2.12.

Apply Kirchoff's Second law to the closed circuit *ABDA*, we get

$$5 - x - z + y = 0 \text{ or } x - y + z = 5 \quad \dots(i)$$

* P.D. between *D* and *B* = drop across *DC* + drop across *CB* = $2 \times 17/91 + 3 \times 18/91 = 88/91$ V.

Similarly, circuit $BCDB$ gives

$$-(x-z) + 5 + (y+z) + z = 0$$

$$\text{or } x - y - 3z = 5 \quad \dots(ii)$$

Lastly, from circuit $ADCEA$, we get

$$-y - (y+z) + 10 - (x+y) = 0$$

$$\text{or } x + 3y + z = 10 \quad \dots(iii)$$

From Eq. (i) and (ii), we get, $z = 0$

Substituting $z = 0$ either in Eq. (i) or (ii) and in Eq. (iii), we get

$$x - y = 5 \quad \dots(iv)$$

$$x + 3y = 10 \quad \dots(v)$$

Subtracting Eq. (v) from (iv), we get

$$-4y = -5 \quad \text{or } y = 5/4 = 1.24 \text{ A}$$

Eq. (iv) gives $x = 25/4 \text{ A} = 6.25 \text{ A}$

Current in branch AB = current in branch BC = **6.25 A**

Current in branch BD = 0; current in branch

AD = current in branch DC = **1.25 A**; current in branch CEA = $6.25 + 1.25 =$ **7.5 A**.

Example 2.10. State and explain Kirchhoff's laws. Determine the current supplied by the battery in the circuit shown in Fig. 2.12 A. **(Elect. Engg. I, Bombay Univ.)**

Solution. Let the current distribution be as shown in the figure. Considering the close circuit $ABCA$ and applying Kirchhoff's Second Law, we have

$$-100x - 300z + 500y = 0$$

$$\text{or } x - 5y + 3z = 0 \quad \dots(i)$$

Similarly, considering the closed loop $BCDB$, we have

$$-300z - 100(y+z) + 500(x-z) = 0$$

$$\text{or } 5x - y - 9z = 0 \quad \dots(ii)$$

Taking the circuit $ABDEA$, we get

$$-100x - 500(x-z) + 100 - 100(x+y) = 0$$

$$\text{or } 7x + y - 5z = 1 \quad \dots(iii)$$

The value of x , y and z may be found by solving the above three simultaneous equations or by the method of determinants as given below :

Putting the above three equations in the matrix form, we have

$$\begin{bmatrix} 1 & -5 & 3 \\ 5 & -1 & -9 \\ 7 & 1 & -5 \end{bmatrix} \begin{bmatrix} x \\ y \\ z \end{bmatrix} = \begin{bmatrix} 0 \\ 0 \\ 1 \end{bmatrix}$$

$$\Delta = \begin{bmatrix} 1 & -5 & 3 \\ 5 & -1 & -9 \\ 7 & 1 & -5 \end{bmatrix} = 240, \Delta_1 = \begin{bmatrix} 0 & -5 & 3 \\ 0 & -1 & -9 \\ 1 & 1 & -5 \end{bmatrix} = 48$$

$$\Delta_2 = \begin{bmatrix} 1 & 0 & 3 \\ 5 & 0 & -9 \\ 7 & 1 & -5 \end{bmatrix} = 24, \Delta_3 = \begin{bmatrix} 1 & -5 & 0 \\ 5 & -1 & 0 \\ 7 & 1 & 1 \end{bmatrix} = 24$$

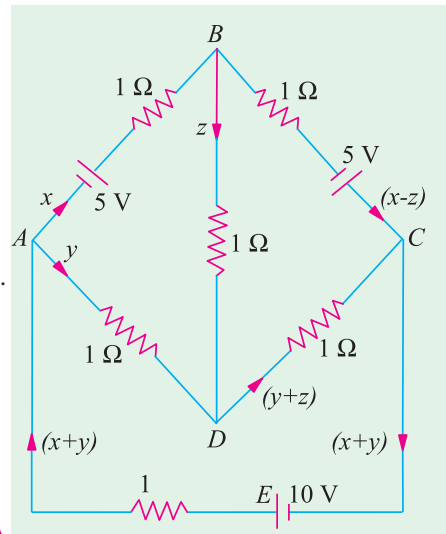

Fig. 2.12

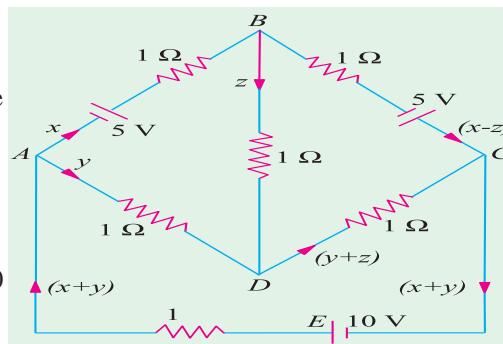

Fig. 2.12 A

$$\therefore x = \frac{48}{240} \frac{1}{5} \text{ A}; y = \frac{24}{240} \frac{1}{10} \text{ A}; z = \frac{24}{240} \frac{1}{10} \text{ A}$$

Current supplied by the battery is $x + y = 1/5 + 1/10 = 3/10 \text{ A}$.

Example 2.11. Two batteries A and B are connected in parallel and load of 10Ω is connected across their terminals. A has an e.m.f. of 12 V and an internal resistance of 2Ω ; B has an e.m.f. of 8 V and an internal resistance of 1Ω . Use Kirchhoff's laws to determine the values and directions of the currents flowing in each of the batteries and in the external resistance. Also determine the potential difference across the external resistance.

(F.Y. Engg. Pune Univ.)

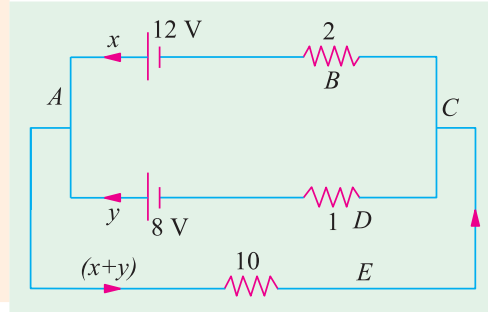

Fig. 2.13

Solution. Applying KVL to the closed circuit ABCDA of Fig. 2.13, we get

$$-12 + 2x - 1y + 8 = 0 \quad \text{or} \quad 2x - y = 4 \quad \dots(i)$$

Similarly, from the closed circuit ADCEA, we get

$$-8 + 1y + 10(x + y) = 0 \quad \text{or} \quad 10x + 11y = 8 \quad \dots(ii)$$

From Eq. (i) and (ii), we get

$$x = 1.625 \text{ A} \quad \text{and} \quad y = -0.75 \text{ A}$$

The negative sign of y shows that the current is flowing into the 8-V battery and not out of it. In other words, it is a charging current and not a discharging current.

Current flowing in the external resistance = $x + y = 1.625 - 0.75 = 0.875 \text{ A}$

P.D. across the external resistance = $10 \times 0.875 = 8.75 \text{ V}$

Note. To confirm the correctness of the answer, the simple check is to find the value of the external voltage available across point A and C with the help of the two parallel branches. If the value of the voltage comes out to be the same, then the answer is correct, otherwise it is wrong. For example, $V_{CBA} = -2 \times 1.625 + 12 = 8.75 \text{ V}$. From the second branch $V_{CDA} = 1 \times 0.75 + 8 = 8.75 \text{ V}$. Hence, the answer found above is correct.

Example 2.12. Determine the current x in the $4\text{-}\Omega$ resistance of the circuit shown in Fig. 2.13 (A).

Solution. The given circuit is redrawn with assumed distribution of currents in Fig. 2.13 (B). Applying KVL to different closed loops, we get

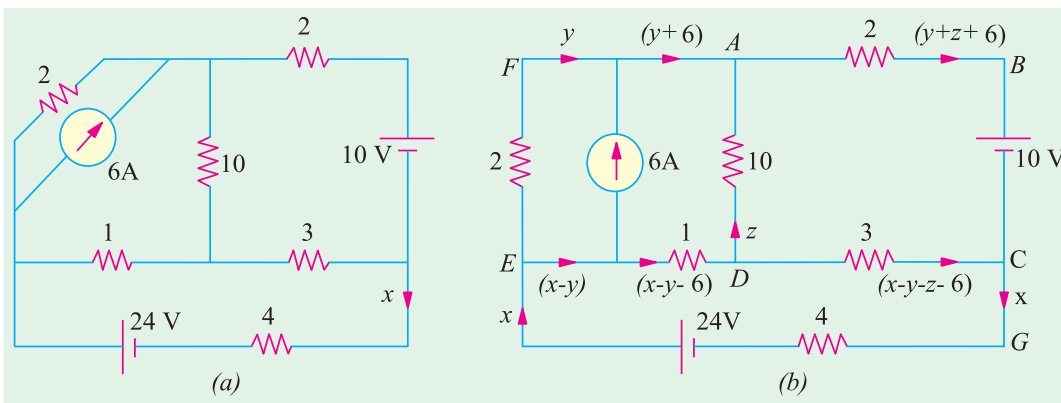

Fig. 2.13 A

Circuit EFADE

$$-2y + 10z + (x - y - 6) = 0 \quad \text{or} \quad x - 3y + 10z = 6 \quad \dots(i)$$

Circuit ABCDA

$$2(y + z + 6) - 10 + 3(x - y - z - 6) - 10z = 0 \quad \text{or} \quad 3x - 5y - 14z = 40 \quad \dots(ii)$$

Circuit EDCGE

$$-(x - y - 6) - 3(x - y - z - 6) - 4x + 24 = 0 \quad \text{or} \quad 8x - 4y - 3z = 48 \quad \dots(iii)$$

From above equations we get $x = 4.1 \text{ A}$

Example 2.13. Applying Kirchhoff's laws to different loops in Fig. 2.14, find the values of V_1 and V_2 .

Solution. Starting from point A and applying Kirchhoff's voltage law to loop No.3, we get

$$-V_3 + 5 = 0 \quad \text{or} \quad V_3 = 5 \text{ V}$$

Starting from point A and applying Kirchhoff's voltage law to loop No. 1, we get

$$10 - 30 - V_1 + 5 = 0 \quad \text{or} \quad V_1 = -15 \text{ V}$$

The negative sign of V_1 denotes that its polarity is opposite to that shown in the figure.

Starting from point B in loop No. 3, we get

$$-(-15) - V_2 + (-15) = 0 \quad \text{or} \quad V_2 = 0$$

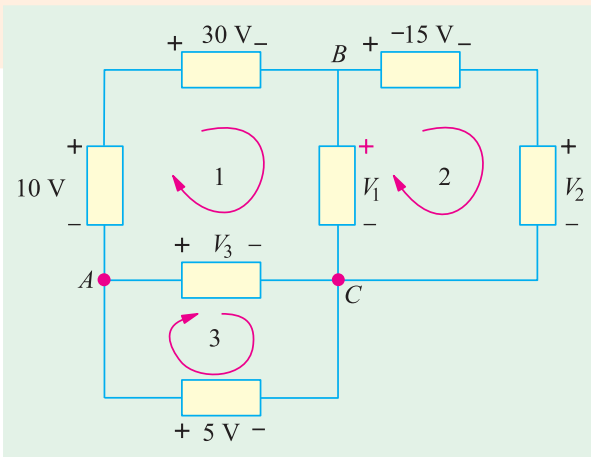

Fig. 2.14

Example 2.14. In the network of Fig. 2.15, the different currents and voltages are as under :

$$i_2 = 5e^{-2t}, \quad i_4 = 3 \sin t \quad \text{and} \quad v_3 = 4e^{-2t}$$

Using KCL, find voltage v_1 .

Solution. According to KCL, the algebraic sum of the currents meeting at junction A is zero i.e.

$$\begin{aligned} i_1 + i_2 + i_3 + (-i_4) &= 0 \\ i_1 + i_2 + i_3 - i_4 &= 0 \end{aligned} \quad \dots(i)$$

Now, current through a capacitor is given by $i = C dv/dt$

$$\therefore i_3 = C \frac{dv_3}{dt} = 2 \frac{d(4e^{-2t})}{dt} = 16e^{-2t}$$

Substituting this value in Eq (i) above, we get

$$i_1 + 5e^{-2t} - 16e^{-2t} - 3 \sin t = 0$$

$$\text{or} \quad i_1 = 3 \sin t + 11e^{-2t}$$

The voltage v_1 developed across the coil is

$$\begin{aligned} v_1 &= L \frac{di_1}{dt} = 4 \cdot \frac{d}{dt} (3 \sin t + 11e^{-2t}) \\ &= 4 (3 \cos t - 22e^{-2t}) = 12 \cos t - 88e^{-2t} \end{aligned}$$

Example 2.15. In the network shown in Fig. 2.16, $v_1 = 4\text{V}$, $v_4 = 4 \cos 2t$ and $i_3 = 2e^{-t/3}$. Determine i_2 .

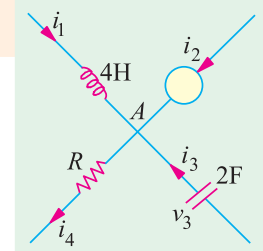

Fig. 2.15

Solution. Applying KVL to closed mesh ABCDA, we get

$$-v_1 - v_2 + v_3 + v_4 = 0$$

Now
$$v_3 = L \frac{di_3}{dt} = 6 \cdot \frac{d}{dt} (2e^{-t/3}) = -4e^{-t/3}$$

$$\therefore -4 - v_2 - 4e^{-t/3} + 4 \cos 2t = 0$$

 or
$$v_2 = 4 \cos 2t - 4e^{-t/3} - 4$$

Now,
$$i_2 = C \frac{dv_2}{dt} = 8 \frac{d}{dt} (4 \cos 2t - 4e^{-t/3} - 4)$$

$$\therefore i_2 = 8 \left(-8 \sin 2t + \frac{4}{3} e^{-t/3} \right) = -64 \sin 2t + \frac{32}{3} e^{-t/3}$$

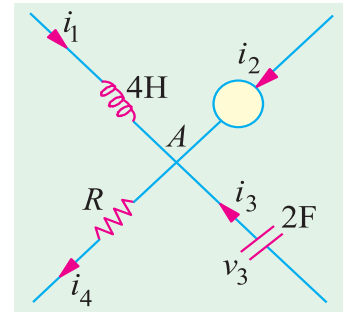

Fig. 2.16

Example 2.16. Use nodal analysis to determine the voltage across 5 Ω resistance and the current in the 12 V source. [Bombay University 2001]

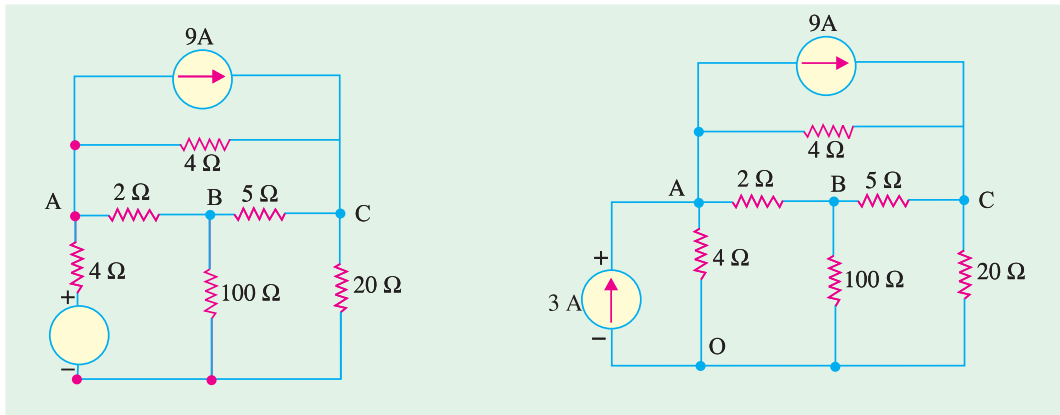

Fig. 2.17 (a)

Fig. 2.17 (b)

Solution. Transform the 12-volt and 4-ohm resistor into current-source and parallel resistor.

Mark the nodes O, A, B and C on the diagram. Self- and mutual conductance terms are to be written down next.

At A, $G_{aa} = 1/4 + 1/2 + 1/4 = 1$ mho

At B, $G_{bb} = 1/2 + 1/5 + 1/100 = 0.71$ mho

At C, $G_{cc} = 1/4 + 1/5 + 1/20 = 0.50$ mho

Between A and B, $G_{ab} = 0.5$ mho,

Between B and C, $G_{bc} = 0.2$ mho,

Between A and C, $G_{ac} = 0.25$ mho.

Current Source matrix : At node A, 3 amp incoming and 9 amp outgoing currents give a net outgoing current of 6 amp. At node C, incoming current = 9 amp. At node B, no current source is

connected. Hence, the current-source matrix is :

$$\begin{bmatrix} -6 \\ 0 \\ 9 \end{bmatrix}$$

The potentials of three nodes to be found are : V_A, V_B, V_C

$$\begin{bmatrix} 1 & -0.5 & -0.25 \\ -0.5 & 0.71 & -0.20 \\ -0.25 & -0.20 & 0.5 \end{bmatrix} \begin{bmatrix} V_A \\ V_B \\ V_C \end{bmatrix} = \begin{bmatrix} -6 \\ 0 \\ 9 \end{bmatrix}$$

For evaluating V_A , V_B , V_C , following steps are required.

$$\Delta = \begin{vmatrix} 1 & -0.5 & -0.25 \\ -0.5 & 0.71 & -0.20 \\ -0.25 & -0.20 & 0.5 \end{vmatrix} = 1 \times (0.710.5 - 0.04) + 0.5 (-0.25 - 0.05) - 0.25 (0.1 + 0.71 \times 0.25)$$

$$= 0.315 - 0.15 - 0.069375 = 0.095625$$

$$\Delta_a = \begin{vmatrix} -6 & -0.5 & -0.25 \\ -0.5 & 0.71 & -0.20 \\ 9 & -0.20 & +0.5 \end{vmatrix} = +0.6075$$

$$\Delta_b = \begin{vmatrix} 1 & -6 & -0.25 \\ -0.5 & 0 & -0.20 \\ -0.25 & 9 & 0.50 \end{vmatrix} = 1.125$$

$$\Delta_c = \begin{vmatrix} 1 & -0.5 & -6 \\ -0.5 & 0.71 & 0 \\ -0.25 & -0.20 & 9 \end{vmatrix} = 2.2475$$

$$V_A = \Delta_a / \Delta = +0.6075 / 0.095625 = 6.353 \text{ volts}$$

$$V_B = \Delta_b / \Delta = 1.125 / 0.095625 = 11.765 \text{ volts}$$

$$V_C = \Delta_c / \Delta = 2.2475 / 0.095625 = 23.503 \text{ volts}$$

Hence, voltage across 5-ohm resistor = $V_C - V_B = 14.18$ volts. Obviously, B is positive w.r. to A . From these node potentials, current through 100-ohm resistor is 0.118 amp; (i) current through 20 ohm resistor is 1.294 amp.

(ii) Current through 5-ohm resistor = $14.18/5 = 2.836$ amp.

(iii) Current through 4-ohm resistor between C and $A = 19.53/4 = 4.883$ amp

Check : Apply KCL at node C

Incoming current = 9 amp, from the source.

Outgoing currents as calculated in (i), (ii) and (iii) above = $1.294 + 2.836 + 4.883 \cong 9$ amp

(iv) Current through 2-ohm resistor = $(V_B - V_A)/2 = 2.706$ amp, from B to A .

(v) Current in $A-O$ branch = $6.353/4 = 1.588$ amp

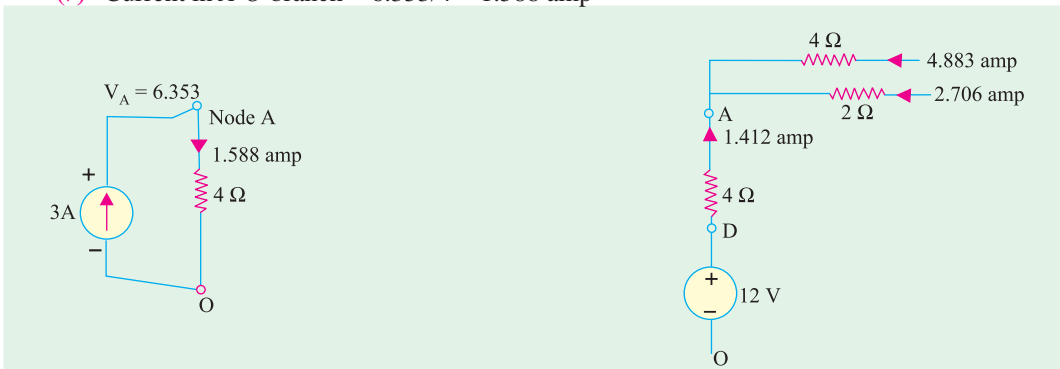

Fig. 2.17 (c) Equivalent

Fig. 2.17 (d) Actual elements

In Fig. 2.17 (c), the transformed equivalent circuit is shown. The 3-amp current source (O to A) and the current of 1.588 amp in $A-O$ branch have to be interpreted with reference to the actual circuit, shown in Fig. 2.17 (d), where in a node D exists at a potential of 12 volts w.r. to the reference node. The 4-ohm resistor between D and A carries an upward current of $\{(12 - 6.353)/4 =\}$ 1.412 amp, which is nothing but 3 amp into the node and 1.588 amp away from the node, as in Fig. 2.17 (c), at node A . The current in the 12-V source is thus 1.412 amp.

Check. KCL at node A should give a check that incoming currents should add-up to 9 amp.

$$1.412 + 2.706 + 4.883 \cong 9 \text{ amp}$$

Example 2.17. Determine current in 5-Ω resistor by any one method.

(Bombay University 2001)

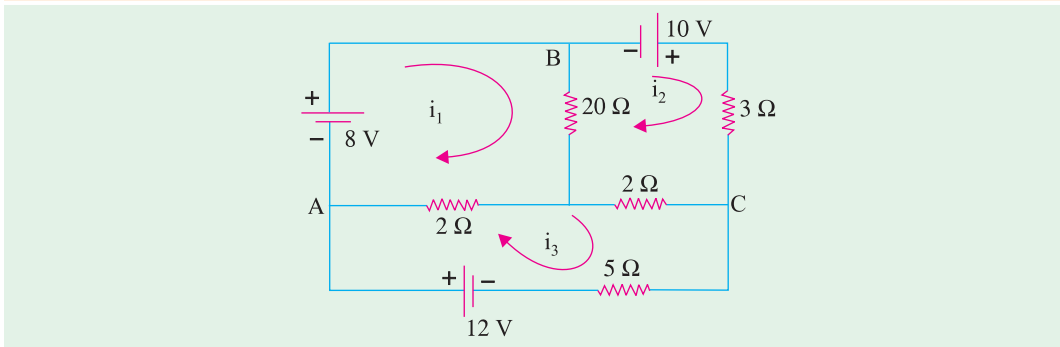

Fig. 2.18 (a)

Solution (A). Matrix-method for Mesh analysis can be used. Mark three loops as shown, in Fig. 2.18 (a). Resistance-matrix should be evaluated for current in 5-ohm resistor. Only, i_3 is to be found.

$$R_{11} = 3, R_{22} = 6, R_{33} = 9 \quad R_{12} = 1, R_{23} = 2, R_{13} = 2$$

Voltage-source will be a column matrix with entries serially as : + 8 Volts, + 10 Volts, + 12 Volts.

$$\Delta = \begin{vmatrix} 3 & -1 & -2 \\ -1 & 6 & -2 \\ -2 & -2 & 9 \end{vmatrix} = 3 \times (54 - 4) + 1(-9 - 4) - 2(2 + 12) = 109$$

$$\Delta_3 = \begin{vmatrix} 3 & -1 & 8 \\ -1 & 6 & 10 \\ -2 & -2 & 12 \end{vmatrix} = 396$$

$$i_3 = \Delta_3 / \Delta = 396 / 109 = 3.633 \text{ amp.}$$

Solution (B). Alternatively, Thevenin's theorem can be applied.

For this, detach the 5-ohm resistor from its position, Evaluate V_{TH} at the terminals X-Y in Fig. 2.18 (b) and de-activating the source, calculate the value of R_{TH} as shown in Fig. 2.18 (c).

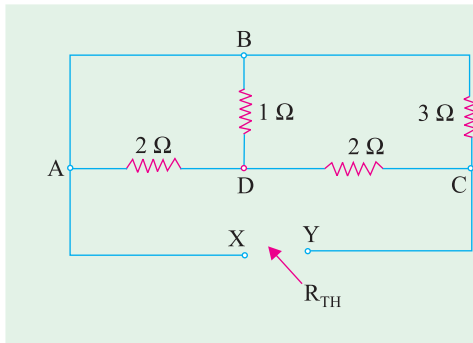

Fig. 2.18 (b)

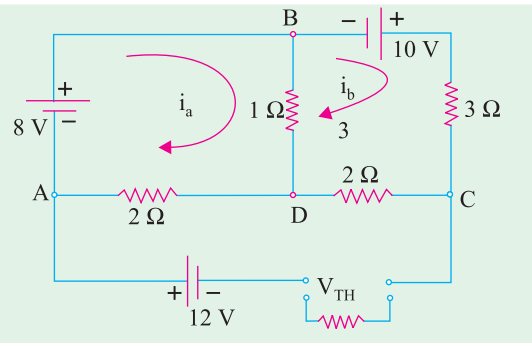

Fig. 2.18 (c)

By observation, Resistance-elements of 2×2 matrix have to be noted.

$$R_{aa} = 3, R_{bb} = 5, R_{ab} = 1$$

$$\begin{vmatrix} 3 & -1 \\ -1 & 6 \end{vmatrix} \begin{vmatrix} i_a \\ i_b \end{vmatrix} = \begin{vmatrix} +8 \\ +10 \end{vmatrix}$$

$$i_a = \left| \begin{array}{cc} 8 & -1 \\ 10 & 6 \end{array} \right| \div \left| \begin{array}{cc} 3 & -1 \\ -1 & 6 \end{array} \right| = 58/17 = 3.412 \text{ amp}$$

$$i_b = \left| \begin{array}{cc} 3 & 8 \\ -1 & 10 \end{array} \right| \div (17) = 38/17 = 2.2353 \text{ amp}$$

$$V_{XY} = V_{TH} = 12 + 2i_a + 2i_b = 23.3 \text{ Volts,}$$

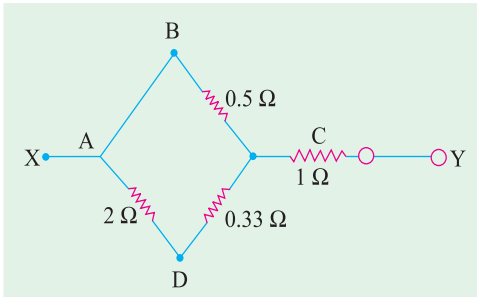

Fig. 2.18 (d)

with y positive w.r. to X. R_{TH} can be evaluated from Fig. 2.18 (c), after transforming delta configuration at nodes B-D-C to its equivalent star, as shown in Fig. 2.18 (d)

Further simplification results into :

$$R_{XY} = R_{TH} = 1.412 \text{ ohms}$$

$$\text{Hence, Load Current} = V_{TH}/(R_L + R_{TH}) = 23.3/6.412 = 3.643 \text{ amp.}$$

This agrees with result obtained earlier.

Example 2.18 (a). Determine the voltages 1 and 2 of the network in Fig. 2.19 (a) by nodal analysis. (Bombay University, 2001)

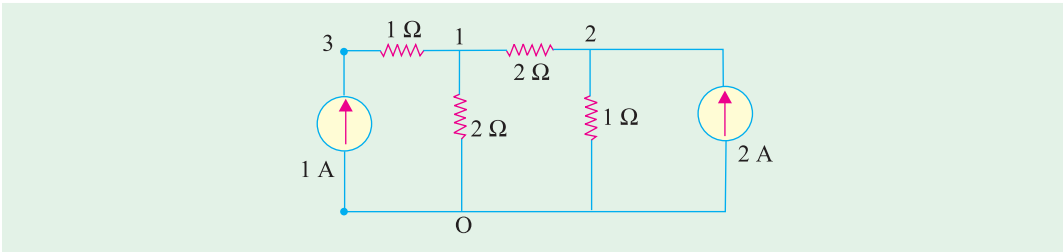

Fig. 2.19 (a)

Solution. Write the conductance matrix for the network, with nodes numbered as 1, 2, 4 as shown.

$$g_{11} = 1 + 0.5 + 0.5 = 2 \text{ mho, } g_{22} = 1 + 0.5 = 1.5 \text{ mho,}$$

$$g_{33} = 1 \text{ mho, } g_{12} = 0.5 \text{ mho, } g_{23} = 0, g_{13} = 1 \text{ mho}$$

$$\Delta = \begin{vmatrix} 2 & -0.5 & -1 \\ -0.5 & 1.5 & 0 \\ -1 & 0 & 1.0 \end{vmatrix} = 1.25, \quad \Delta_1 = \begin{vmatrix} 0 & -0.5 & -1 \\ 2 & 1.5 & 0 \\ 1 & 0 & 1 \end{vmatrix} = 2.5$$

$$\Delta_2 = \begin{vmatrix} 2 & 0 & -1 \\ -0.5 & 2 & 0 \\ -1 & 1 & 1.0 \end{vmatrix} = 2.5$$

This gives $V_1 = \Delta_1/\Delta = 2.50/1.25 = 2 \text{ Volts}$

And $V_2 = \Delta_2/\Delta = 2.50/1.25 = 2 \text{ Volts}$

It means that the 2-ohm resistor between nodes 1 and 2 does not carry current.

Example 2.18 (b). In the circuit of Fig. 2.19 (b), find current through 1-ohm resistor using both THEVENIN's theorem and SUPERPOSITION theorem.

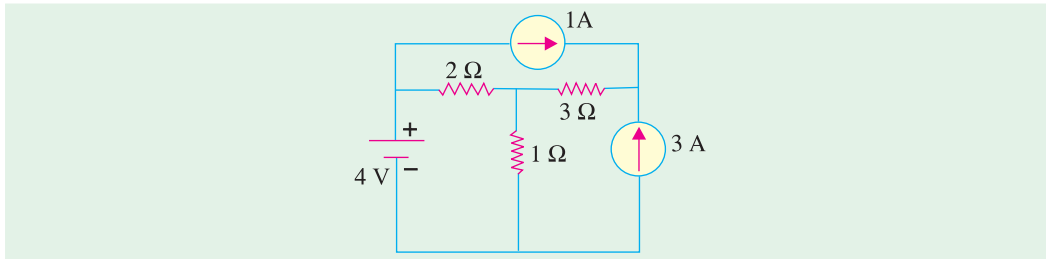

Fig. 2.19 (b)

Solution. (i) By Thevenin's Theorem :

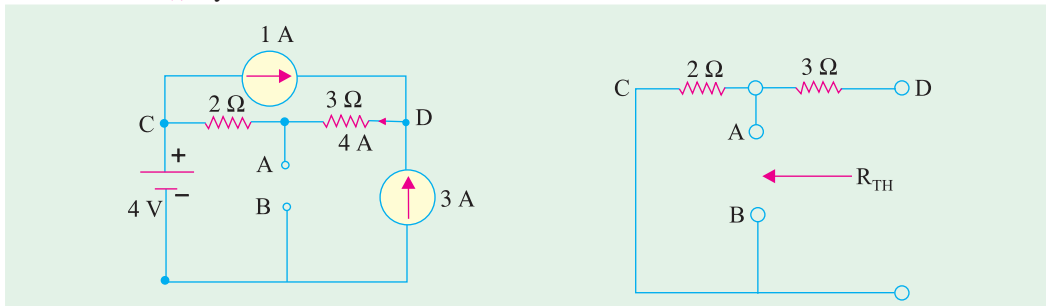

Fig. 2.19 (c)

Fig. 2.19 (d)

Take $V_B = 0$. Then $V_A = 4 + 8 = 12$, since from D to C , a current of 4 A must flow, as shown in Fig. 2.19 (b), applying KCL of Node D .

$$V_{TH} = V_{AB} = 12 \text{ volts}$$

From Fig. 2.19 (d), $R_{TH} = 2 \text{ ohms}$

$$I_L = 12 / (2 + 1) = 4 \text{ amp}$$

(ii) By Superposition Theorem : One source acts at a time. Current through $A-B$ (1 ohm) is to be calculated due to each source and finally all these contributions added.

Due to 4-V source :

1-ohm resistor carries a current of $4/3$ amp from A to B , as shown in Fig. 2.19 (e).

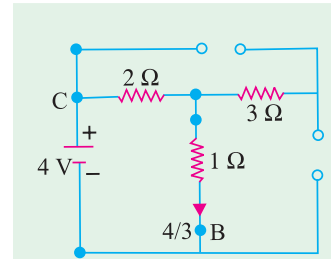

Fig. 2.19 (e). 4-V Source acts

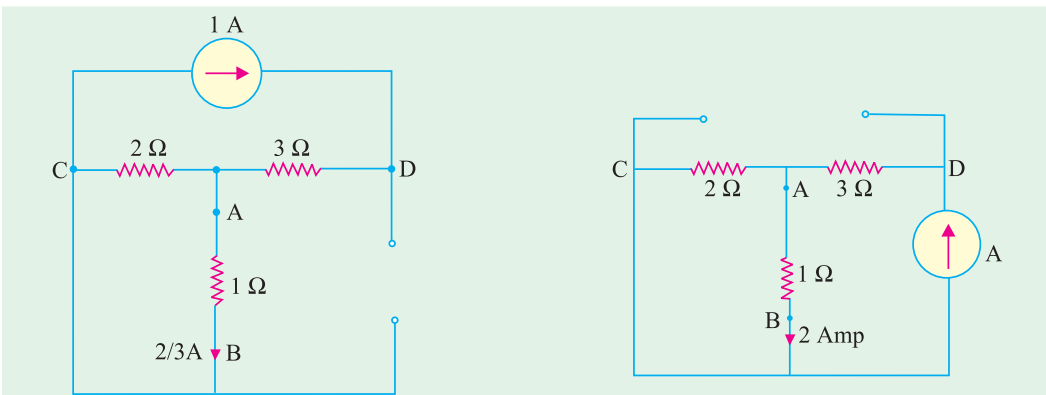

Fig. 2.19 (f). 1-A Source acts

Fig. 2.19 (g). 3-A Source acts

Due to 1-A source : $2/3$ Amp from A to B , as shown in Fig. 2.19 (f)

Due to 3-A source : 2 Amp from A to B as shown in Fig. 2.19 (g)

Total current = 4 amp from A to B .

2.9. Independent and Dependent Sources

Those voltage or current sources, which do not depend on any other quantity in the circuit, are called independent sources. An independent d.c. voltage source is shown in Fig. 2.20 (a) whereas a time-varying voltage source is shown in Fig. 2.20 (b). The positive sign shows that terminal A is positive with respect to terminal B. In other words, potential of terminal A is v volts higher than that of terminal B.

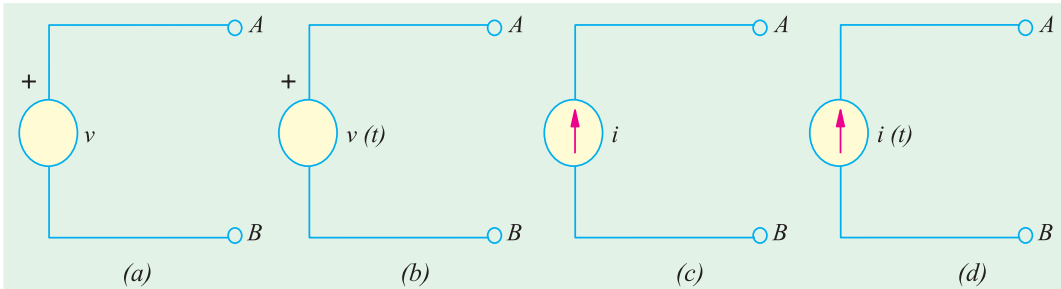

Fig. 2.20

$$\Delta_2 = \begin{vmatrix} 2 & -0.5 & -1 \\ -0.5 & 1.5 & 0 \\ -1 & 0 & 1.0 \end{vmatrix} = 1.25, \quad \Delta_1 = \begin{vmatrix} 0 & -0.5 & -1 \\ 2 & 1.5 & 0 \\ 1 & 0 & 1 \end{vmatrix} = 2.5$$

Similarly, Fig. 2.20 (c) shows an ideal constant current source whereas Fig. 2.20 (d) depicts a time-varying current source. The arrow shows the direction of flow of the current at any moment under consideration.

A dependent voltage or current source is one which depends on some other quantity in the circuit which may be either a voltage or a current. Such a source is represented by a diamond-shaped symbol as shown in Fig. 2.21 so as not to confuse it with an independent source. There are four possible dependent sources :

1. Voltage-dependent voltage source [Fig. 2.21 (a)]
2. Current-dependent voltage source [Fig. 2.21 (b)]
3. Voltage-dependent current source [Fig. 2.21 (c)]
4. Current-dependent current source [Fig. 2.21 (d)]

Such sources can also be either constant sources or time-varying sources. Such sources are often met in electronic circuits. As seen above, the voltage or current source is dependent on the and is

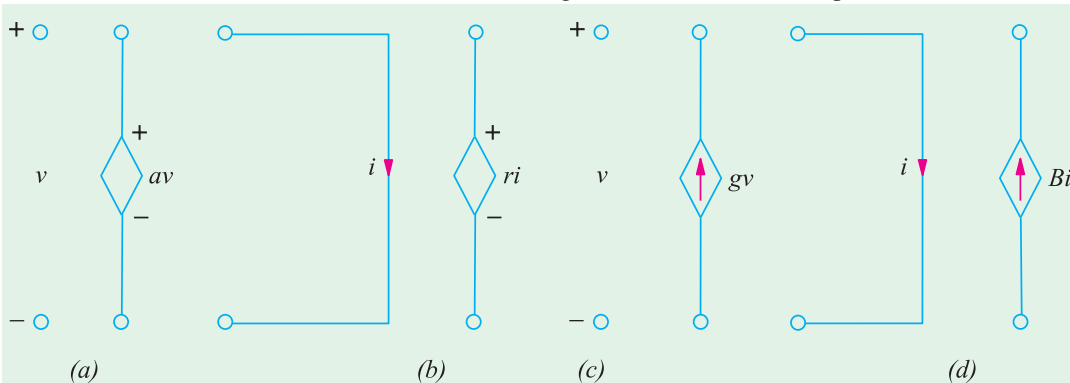

Fig. 2.21

proportional to another current or voltage. The constants of proportionality are written as a , r , g and β . The constants a and β have no units, r has the unit of ohms and g has the unit of siemens.

Independent sources actually exist as physical entities such as a battery, a *d.c.* generator and an alternator etc. But dependent sources are parts of *models* that are used to represent electrical properties of electronic devices such as operational amplifiers and transistors etc.

Example 2.19. Using Kirchhoff's current law, find the values of the currents i_1 and i_2 in the circuit of Fig. 2.22 (a) which contains a current-dependent current source. All resistances are in ohms.

Solution. Applying KCL to node A, we get

$$2 - i_1 + 4i_1 - i_2 = 0 \quad \text{or} \quad -3i_1 + i_2 = 2$$

By Ohm's law, $i_1 = v/3$ and $i_2 = v/2$

Substituting these values above, we get

$$-3(v/3) + v/2 = 2 \quad \text{or} \quad v = -4 \text{ V}$$

$$\therefore \quad i_1 = -4/3 \text{ A and } i_2 = -4/2 = -2 \text{ A}$$

The value of the dependent current source is $= 4i_1 = 4 \times (-4/3) = -16/3 \text{ A}$.

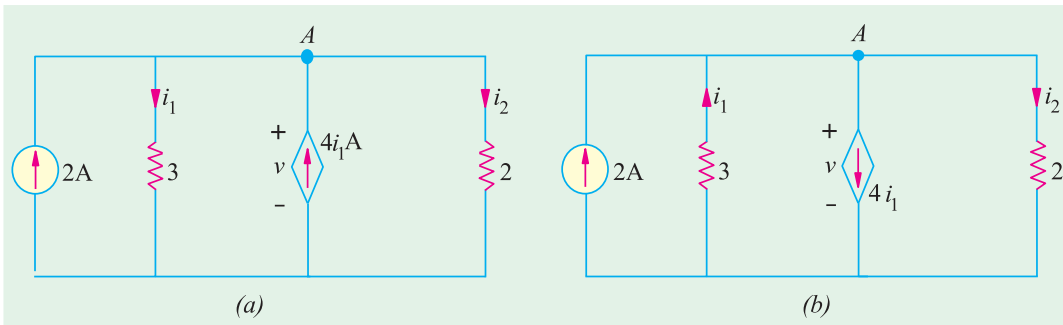

Fig. 2.22

Since i_1 and i_2 come out to be negative, it means that they flow upwards as shown in Fig. 2.22(b) and not downwards as presumed. Similarly, the current of the dependent source flows downwards as shown in Fig. 2.22 (b). It may also be noted that the sum of the upwards currents equals that of the downward currents.

Example 2.20. By applying Kirchhoff's current law, obtain the values of v , i_1 and i_2 in the circuit of Fig. 2.23 (a) which contains a voltage-dependent current source. Resistance values are in ohms.

Solution. Applying KCL to node A of the circuit, we get

$$2 - i_1 + 4v - i_2 = 0 \quad \text{or} \quad i_1 + i_2 - 4v = 2$$

Now, $i_1 = v/3$ and $i_2 = v/6$

$$\therefore \quad \frac{v}{3} + \frac{v}{6} - 4v = 2 \quad \text{or} \quad v = -\frac{4}{7} \text{ V}$$

$$\therefore \quad i_1 = \frac{4}{21} \text{ A and } i_2 = \frac{2}{21} \text{ A and } 4v = 4 \times \frac{4}{7} = \frac{16}{7} \text{ V}$$

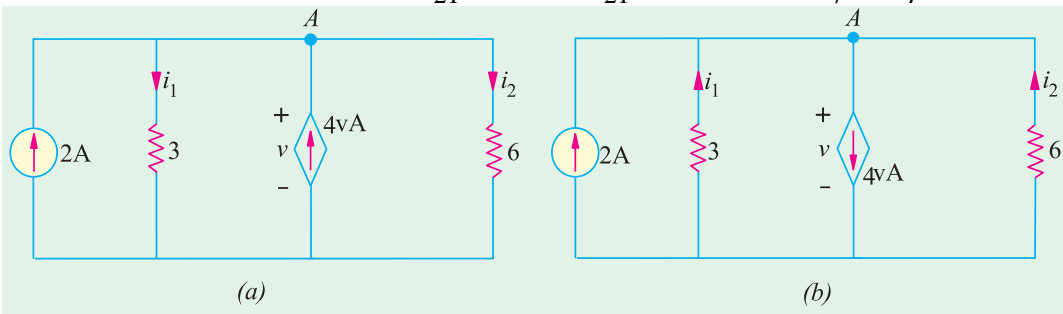

Fig. 2.23

Since i_1 and i_2 come out to be negative and value of current source is also negative, their directions of flow are opposite to those presumed in Fig. 2.23 (a). Actual current directions are shown in Fig. 2.23 (b).

Example 2.21. Apply Kirchhoff's voltage law, to find the values of current i and the voltage drops v_1 and v_2 in the circuit of Fig. 2.24 which contains a current-dependent voltage source. What is the voltage of the dependent source? All resistance values are in ohms.

Solution. Applying KVL to the circuit of Fig. 2.24 and starting from point A, we get

$$-v_1 + 4i - v_2 + 6 = 0 \quad \text{or} \quad v_1 - 4i + v_2 = 6$$

Now, $v_1 = 2i$ and $v_2 = 4i$

$$\therefore 2i - 4i + 4i = 6 \quad \text{or} \quad i = 3\text{A}$$

$$\therefore v_1 = 2 \times 3 = 6\text{V} \quad \text{and} \quad v_2 = 4 \times 3 = 12\text{V}$$

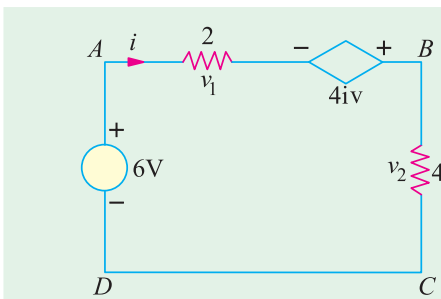

Fig. 2.24

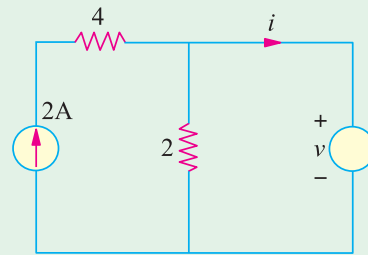

Fig. 2.25

Voltage of the dependent source = $4i = 4 \times 4 = 12\text{V}$

Example 2.22. In the circuit shown in Fig. 2.25, apply KCL to find the value of i for the case when (a) $v = 2\text{V}$, (b) $v = 4\text{V}$ (c) $v = 6\text{V}$. The resistor values are in ohms.

Solution. (a) When $v = 2\text{V}$, current through $2\ \Omega$ resistor which is connected in parallel with the 2V source = $2/2 = 1\text{A}$. Since the source current is 2A , $i = 2 - 1 = 1\text{A}$.

(b) When $v = 4\text{V}$, current through the $2\ \Omega$ resistor = $4/2 = 2\text{A}$. Hence $i = 2 - 2 = 0\text{A}$.

(c) When $v = 6\text{V}$, current through the $2\ \Omega$ resistor = $6/2 = 3\text{A}$. Since current source can supply only 2A , the balance of 1A is supplied by the voltage source. Hence, $i = -1\text{A}$ i.e. it flows in a direction opposite to that shown in Fig. 2.25.

Example 2.23. In the circuit of Fig. 2.26, apply KCL to find the value of current i when (a) $K = 2$ (b) $K = 3$ and (c) $K = 4$. Both resistances are in ohms.

Solution. Since $6\ \Omega$ and $3\ \Omega$ resistors are connected in parallel across the 24-V battery, $i_1 = 24/6 = 4\text{A}$.

Applying KCL to node A, we get $i - 4 + 4K - 8 = 0$ or $i = 12 - 4K$.

(a) When $K = 2$, $i = 12 - 4 \times 2 = 4\text{A}$

(b) When $K = 3$, $i = 12 - 4 \times 3 = 0\text{A}$

(c) When $K = 4$, $i = 12 - 4 \times 4 = -4\text{A}$

It means that current i flows in the opposite direction.

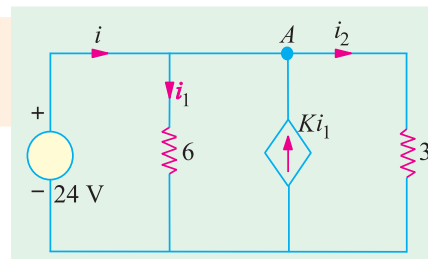

Fig. 2.26

Example 2.24. Find the current i and also the power and voltage of the dependent source in Fig. 2.72 (a). All resistances are in ohms.

Solution. The two current sources can be combined into a single source of $8 - 6 = 2$ A. The two parallel 4Ω resistances when combined have a value of 2Ω which, being in series with the 10Ω resistance, gives the branch resistance of $10 + 2 = 12 \Omega$. This 12Ω resistance when combined with the other 12Ω resistance gives a combination resistance of 6Ω . The simplified circuit is shown in Fig. 2.27 (b.)

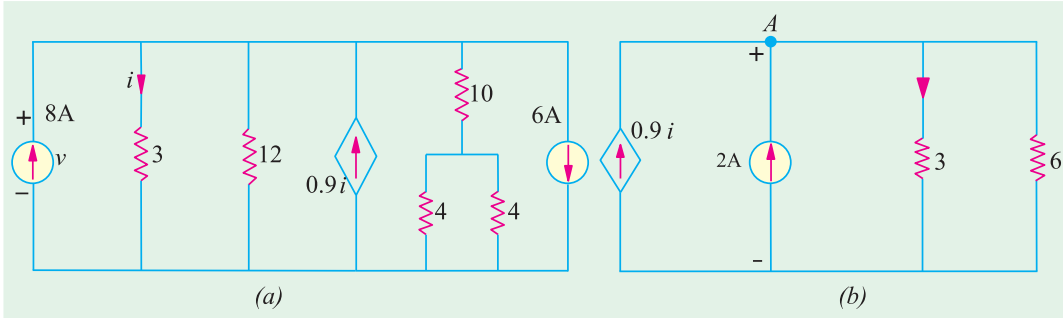

Fig. 2.27

Applying KCL to node A, we get

$$0.9i + 2 - i - V/6 = 0 \quad \text{or} \quad 0.6i = 12 - v$$

Also $v = 3i \therefore i = 10/3$ A. Hence, $v = 10$ V.

The power furnished by the current source = $v \times 0.9i = 10 \times 0.9(10/3) = 30$ W.

Example 2.25. By using voltage-divider rule, calculate the voltages v_x and v_y in the network shown in Fig. 2.28.

Solution. As seen, 12 V drop in over the series combination of 1, 2 and 3 Ω resistors. As per voltage-divider rule $v_x =$ drop over $3 \Omega = 12 \times 3/6 = 6$ V.

The voltage of the dependent source = $12 \times 6 = 72$ V.

The voltage v_y equals the drop across 8Ω resistor connected across the voltage source of 72 V.

Again using voltage-divider rule, drop over 8Ω resistor = $72 \times 8/12 = 48$ V.

Hence, $v_y = -48$ V. The negative sign has been given because positive and negative signs of v_y are actually opposite to those shown in Fig. 2.28.

Example 2.26. Use KCL to find the value of v in the circuit of Fig. 2.29.

Solution. Let us start from ground and go to point a and find the value of voltage v_a . Obviously, $5 + v = v_a$ or $v = v_a - 5$. Applying KCL to point, we get

$$6 - 2v + (5 - v_a)/1 = 0 \quad \text{or} \quad 6 - 2(v_a - 5) + (5 - v_a) = 0 \quad \text{or} \quad v_a = 7 \text{ V}$$

Hence, $v = v_a - 5 = 7 - 5 = 2$ V. Since it turns out to be positive, its sign as indicated in the figure is correct.

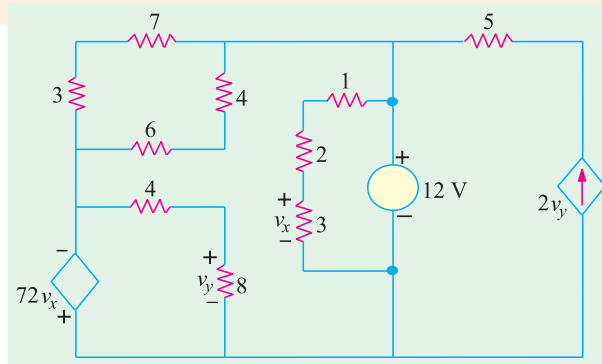

Fig. 2.28

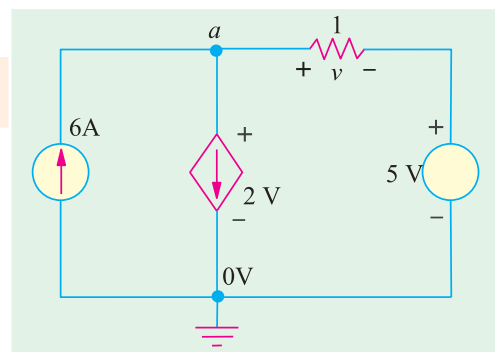

Fig. 2.29

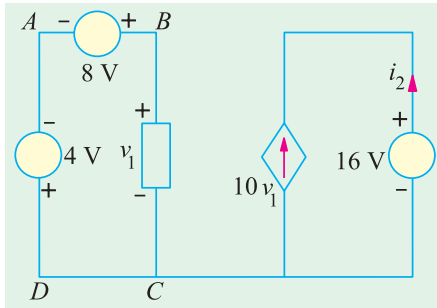

Fig. 2.30

Example 2.27. (a) Basic Electric Circuits by Cunningham.

Find the value of current i_2 supplied by the voltage-controlled current source (VCCS) shown in Fig. 2.30.

Solution. Applying KVL to the closed circuit ABCD, we have $-4 + 8 - v_1 = 0 \therefore v_1 = 4 \text{ V}$

The current supplied by VCCS is $10 v_1 = 10 \times 4 = 40 \text{ A}$. Since i_2 flows in an opposite direction to this current, hence $i_2 = -40 \text{ A}$.

Example 2.27. (b). Find the voltage drop v_2 across the current-controlled voltage source (CCVS) shown in Fig. 2.28.

Solution. Applying KCL to point A, we have $2 + 6 - i_1 = 0$ or $i_1 = 8 \text{ A}$.

Application of KVL to the closed circuit on the right hand side gives $5 i_1 - v_2 = 0$ or $v_2 = 5 i_1 = 5 \times 8 = 40 \text{ V}$.

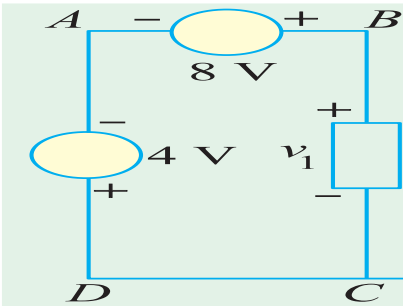

Fig. 2.31

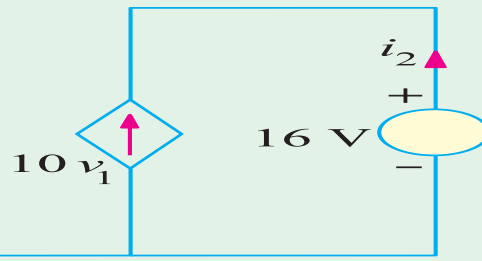

Fig. 2.32

Example 2.28. Find the values of i_1 , v_1 , v_x and v_{ab} in the network of Fig. 2.32 with its terminals a and b open.

Solution. It is obvious that $i_1 = 4 \text{ A}$. Applying KVL to the left-hand closed circuit, we get $-40 + 20 - v_1 = 0$ or $v_1 = -20 \text{ V}$.

Similarly, applying KVL to the second closed loop, we get

$$v_1 - v_x + 4v_1 - 50 = 0 \text{ or } v_x = 5 v_1 - 50 = -5 \times 20 - 50 = -150 \text{ V}$$

Again applying KVL to the right-hand side circuit containing v_{ab} , we get

$$50 - 4v_1 - 10 v_{ab} = 0 \text{ or } v_{ab} = 50 - 4(-20) - 10 = 120 \text{ V}$$

Example 2.29 (a). Find the current i in the circuit of Fig. 2.33. All resistances are in ohms.

Solution. The equivalent resistance of the two parallel paths across point a is $3 \parallel (4 + 2) = 2 \Omega$. Now, applying KVL to the closed loop, we get $24 - v - 2v - 2i = 0$. Since $v = 2i$, we get $24 - 2i - 2(2i) - 2i = 0$ or $i = 3 \text{ A}$.

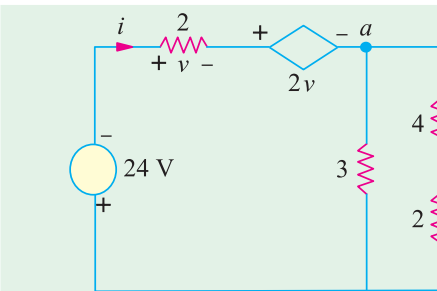

Fig. 2.33

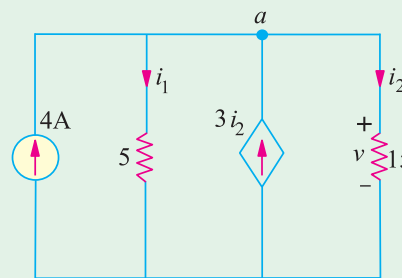

Fig. 2.34

Example 2.29. (b) Determine the value of current i_2 and voltage drop v across $15\ \Omega$ resistor in Fig. 2.34.

Solution. It will be seen that the dependent current source is related to i_2 . Applying KCL to node a , we get $4 - i_1 + 3i_2 - i_2 = 0$ or $4 - i_1 + 3i_2 = 0$.

Applying ohm's law, we get $i_1 = v/5$ and $i_2 = v/15$.

Substituting these values in the above equation, we get $4 - (v/5) + 3(v/15) = 0$ or $v = 60\ \text{V}$ and $i_2 = 4\ \text{A}$.

Example 2.29 (c). In the circuit of Fig. 2.35, find the values of i and v . All resistances are in ohms.

Solution. It may be noted that $12 + v = v_a$ or $v = v_a - 12$. Applying KCL to node a , we get

$$\frac{0 - v_a}{2} + \frac{v}{4} - \frac{v_a - 12}{2} = 0 \quad \text{or} \quad v_a = 4\ \text{V}$$

Hence, $v = 4 - 12 = -8\ \text{V}$. The negative sign shows that its polarity is opposite to that shown in Fig. 2.35. The current flowing from the point a to ground is $4/2 = 2\ \text{A}$. Hence, $i = -2\ \text{A}$.

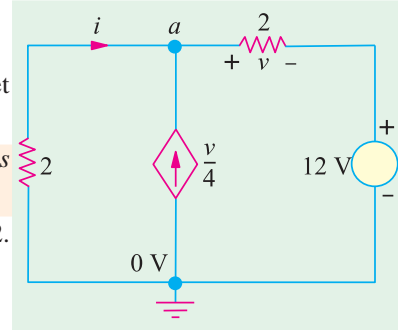

Fig. 2.35

Tutorial Problems No. 2.1

1. Apply KCL to find the value of I in Fig. 2.36.

[8 A]

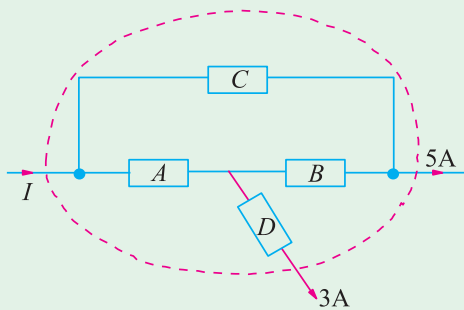

Fig. 2.36

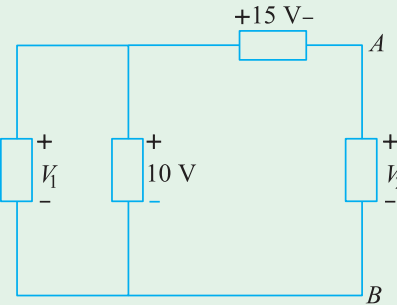

Fig. 2.37

2. Applying Kirchhoff's voltage law, find V_1 and V_2 in Fig. 2.37.

[$V_1 = 10\ \text{V}$; $V_2 = 5\ \text{V}$]

3. Find the values of currents I_2 and I_4 in the network of Fig. 2.38.

[$I_2 = 4\ \text{A}$; $I_4 = 5\ \text{A}$]

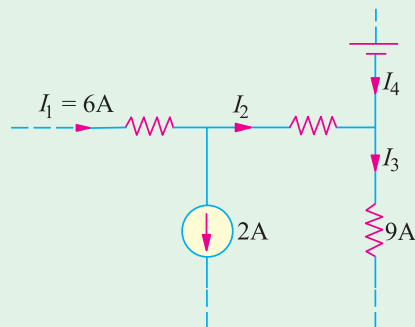

Fig. 2.38

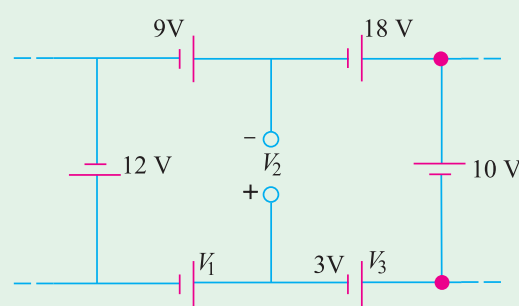

Fig. 2.39

4. Use Kirchhoff's law, to find the values of voltages V_1 and V_2 in the network shown in Fig. 2.39.

[$V_1 = 2\ \text{V}$; $V_2 = 5\ \text{V}$]

5. Find the unknown currents in the circuits shown in Fig. 2.40 (a).

$[I_1 = 2 \text{ A} ; I_2 = 7 \text{ A}]$

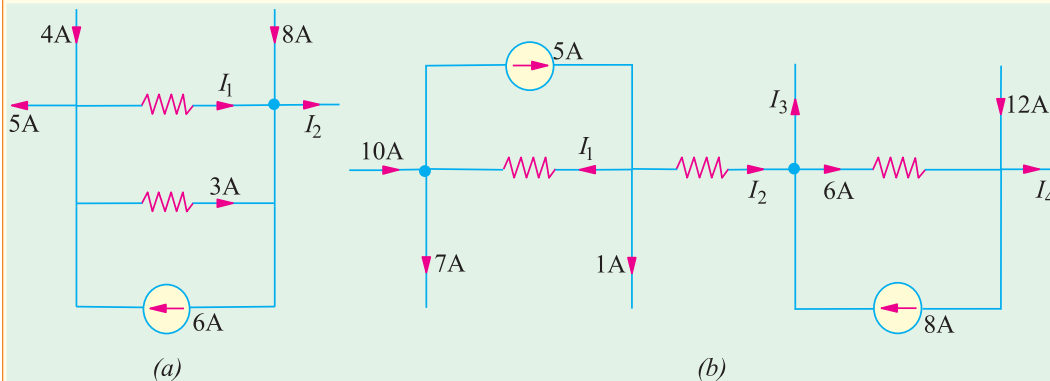

Fig. 2.40

6. Using Kirchhoff's current law, find the values of the unknown currents in Fig. 2.40 (b).

$[I_1 = 2 \text{ A} ; I_2 = 2 \text{ A} ; I_3 = 4 \text{ A} ; I_4 = 10 \text{ A}]$

7. In Fig. 2.41, the potential of point A is -30 V . Using Kirchhoff's voltage law, find (a) value of V and (b) power dissipated by 5Ω resistance. All resistances are in ohms.

$[100 \text{ V} ; 500 \text{ W}]$

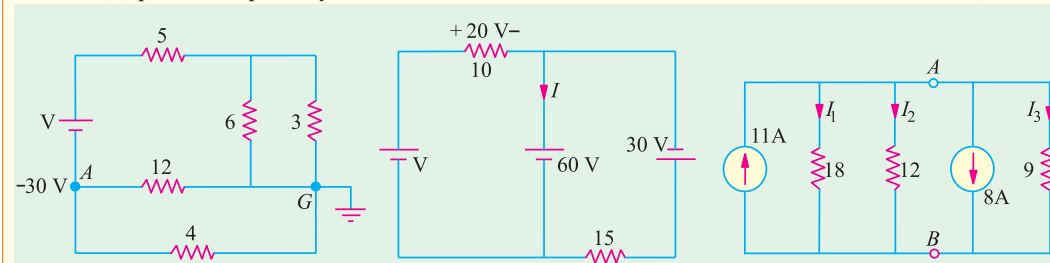

Fig. 2.41

Fig. 2.42

Fig. 2.43

8. Using KVL and KCL, find the values of V and I in Fig. 2.42. All resistances are in ohms.

$[80 \text{ V} ; -4 \text{ A}]$

9. Using KCL, find the values V_{AB} , I_1 , I_2 and I_3 in the circuit of Fig. 2.43. All resistances are in ohms.

$[V_{AB} = 12 \text{ V} ; I_1 = 2/3 \text{ A} ; I_2 = 1 \text{ A} ; I_3 = 4/3 \text{ A}]$

10. A bridge network $ABCD$ is arranged as follows :

Resistances between terminals $A-B$, $B-C$, $C-D$, $D-A$, and $B-D$ are 10 , 20 , 15 , 5 and 40 ohms respectively. A 20 V battery of negligible internal resistance is connected between terminals A and C . Determine the current in each resistor.

$[AB = 0.645 \text{ A} ; BC = 0.678 \text{ A} ; AD = 1.025 \text{ A} ; DB = 0.033 \text{ A} ; DC = 0.992 \text{ A}]$

11. Two batteries A and B are connected in parallel and a load of 10Ω is connected across their terminals. A has an e.m.f. of 12 V and an internal resistance of 2Ω ; B has an e.m.f. of 8 V and an internal resistance of 1Ω . Use Kirchhoff's laws to determine the values and directions of the currents flowing in each of the batteries and in the external resistance. Also determine the p.d. across the external resistance.

$[I_A = 1.625 \text{ A (discharge)}, I_B = 0.75 \text{ A (charge)} ; 0.875 \text{ V} ; 8.75 \text{ V}]$

12. The four arms of a Wheatstone bridge have the following resistances ; $AB = 100$, $BC = 10$, $CD = 4$, $DA = 50$ ohms.

A galvanometer of 20 ohms resistance is connected across BD . Calculate the current through the galvanometer when a potential difference of 10 volts is maintained across AC .

$[0.00513 \text{ A}]$ [Elect. Tech. Lond. Univ.]

13. Find the voltage V_{da} in the network shown in Fig. 2.44 (a) if R is 10Ω and (b) 20Ω

$[(a) 5 \text{ V} (b) 5 \text{ V}]$

14. In the network of Fig. 2.44 (b), calculate the voltage between points a and b i.e. V_{ab} .

$[30 \text{ V}]$ (Elect. Engg. I, Bombay Univ.)

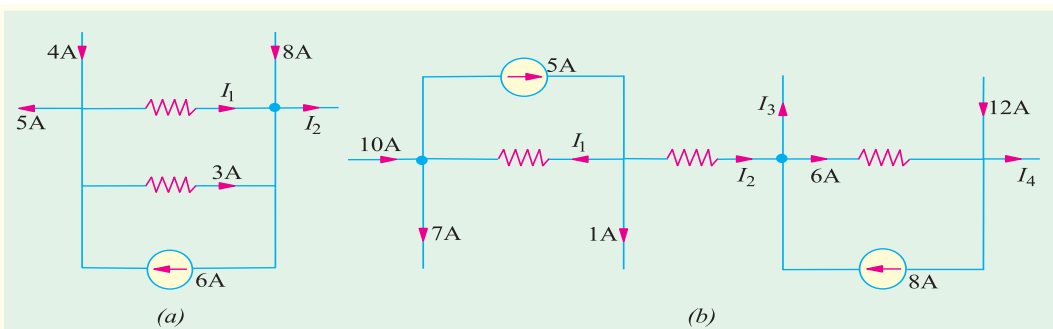

Fig. 2.44

[Hint : In the above two cases, the two closed loops are independent and no current passes between them].

15. A battery having an *E.M.F.* of 110 V and an internal resistance of 0.2Ω is connected in parallel with another battery having an *E.M.F.* of 100 V and internal resistance 0.25Ω . The two batteries in parallel are placed in series with a regulating resistance of 5Ω and connected across 200 V mains. Calculate the magnitude and direction of the current in each battery and the total current taken from the supply mains.

[$I_A = 11.96$ (discharge); $I_B = 30.43$ A (charge) : 18.47 A] (*Elect Technology, Sumbhal Univ.*)

16. Three batteries *P*, *Q* and *R* consisting of 50, 55 and 60 cells in series respectively supply in parallel a common load of 100 A. Each cell has a e.m.f. of 2 V and an internal resistance of 0.005Ω . Determine the current supplied by each battery and the load voltage.

[1.2 A ; 35.4 A : 65.8 A : 100.3 V] (*Basic Electricity, Bombay Univ.*)

17. Two storage batteries are connected in parallel to supply a load having a resistance of 0.1Ω . The open-circuit e.m.f. of one battery (*A*) is 12.1 V and that of the other battery (*B*) is 11.8 V. The internal resistances are 0.03Ω and 0.04Ω respectively. Calculate (i) the current supplied at the lead (ii) the current in each battery (iii) the terminal voltage of each battery.

[(i) 102.2 A (ii) 62.7 A (A), 39.5 A (B) (iii) 10.22 V] (*London Univ.*)

18. Two storage batteries, *A* and *B*, are connected in parallel to supply a load the resistance of which is 1.2Ω . Calculate (i) the current in this load and (ii) the current supplied by each battery if the open-circuit e.m.f. of *A* is 12.5 V and that of *B* is 12.8 V, the internal resistance of *A* being 0.05Ω and that of *B* 0.08Ω .

[(i) 10.25 A (ii) 4 (A), 6.25 A (B)] (*London Univ.*)

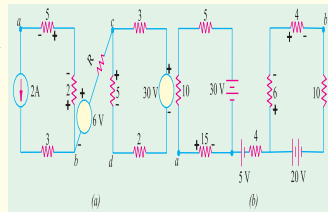

Fig. 2.45

19. The circuit of Fig. 2.45 contains a voltage-dependent voltage source. Find the current supplied by the battery and power supplied by the voltage source. Both resistances are in ohms. [8 A ; 1920 W]

20. Find the equivalent resistance between terminals *a* and *b* of the network shown in Fig. 2.46. [2 Ω]

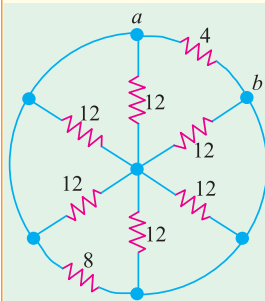

Fig. 2.46

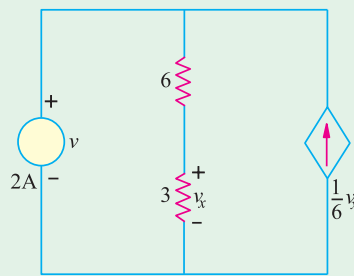

Fig. 2.47

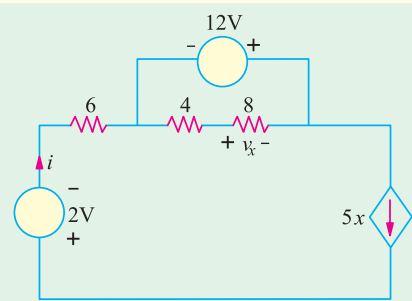

Fig. 2.48

21. Find the value of the voltage v in the network of Fig. 2.47. [36 V]
 22. Determine the current i for the network shown in Fig. 2.48. [-40 A]
 23. State and explain Kirchhoff's current law. Determine the value of R_S and R_P in the network of Fig. 2.49 if $V_2 = V_1/2$ and the equivalent resistance of the network between the terminals A and B is 100Ω .
 24. Four resistance each of R ohms and two resistances each of S ohms are connected (as shown in Fig. 2.50) to four terminals AB and CD . A p.d. of V volts is applied across the terminals AB and a resistance of Z ohm is connected across the terminals CD . Find the value of Z in terms of S and R in order that the current at AB may be V/Z .

Find also the relationship that must hold between R and S in order that the p.d. at the points EF be $V/2$.
 [$Z = \sqrt{R(R + 2S)}$; $S = 4R$]

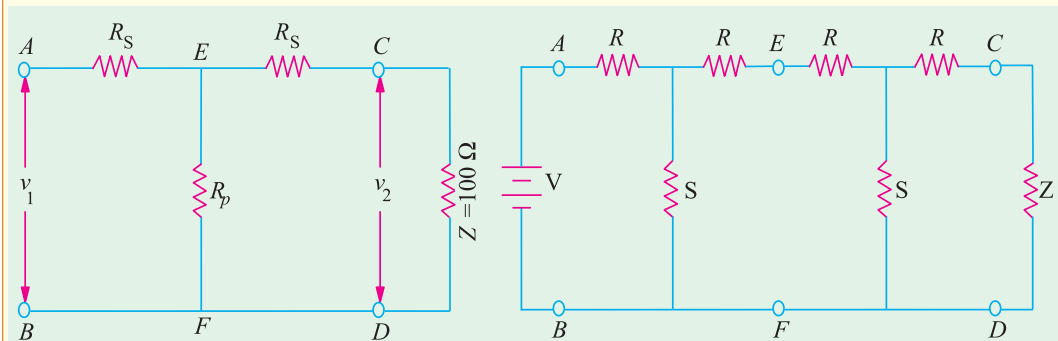

Fig. 2.49

Fig. 2.50

2.10. Maxwell's Loop Current Method

This method which is particularly well-suited to coupled circuit solutions employs a system of **loop** or **mesh** currents instead of **branch** currents (as in Kirchhoff's laws). Here, the currents in different meshes are assigned continuous paths so that they do not split at a junction into branch currents. This method eliminates a great deal of tedious work involved in the branch-current method and is best suited when energy sources are voltage sources rather than current sources. Basically, this method consists of writing loop voltage equations by Kirchhoff's voltage law in terms of unknown loop currents. As will be seen later, the number of independent equations to be solved reduces from b by Kirchhoff's laws to $b - (j - 1)$ for the loop current method where b is the number of branches and j is the number of junctions in a given network.

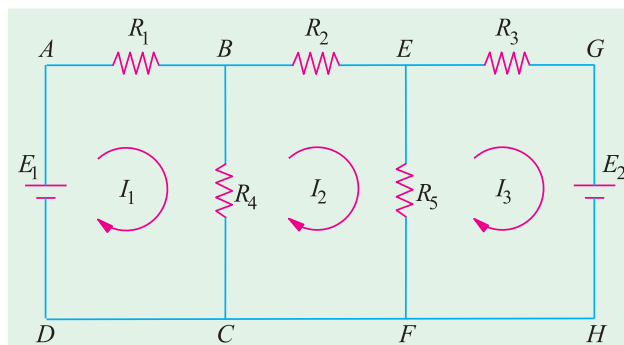

Fig. 2.51

Fig. 2.51 shows two batteries E_1 and E_2 connected in a network consisting of five resistors. Let the loop currents for the three meshes be I_1, I_2 and I_3 . It is obvious that current through R_4 (when considered as a part of the first loop) is $(I_1 - I_2)$ and that through R_5 is $(I_2 - I_3)$. However, when R_4 is considered part of the second loop, current through it is $(I_2 - I_1)$. Similarly, when R_5 is considered part of the third loop, current through it is $(I_3 - I_2)$. Applying Kirchhoff's voltage law to the three loops, we get,

$$E_1 - I_1 R_1 - R_4 (I_1 - I_2) = 0 \quad \text{or} \quad I_1 (R_1 + R_4) - I_2 R_4 - E_1 = 0 \quad \dots \text{loop 1}$$

Similarly, $-I_2R_2 -R_5 (I_2 -I_3) -R_4 (I_2 -I_1) = 0$

or $I_2 R_4 -I_2 (R_2 + R_4 + R_5) + I_3R_5 = 0$

...loop 2

Also $-I_3R_3 -E_2 -R_5 (I_3 -I_2) = 0$ or $I_2R_5 -I_3 (R_3 + R_5) -E_2 = 0$

...loop 3

The above three equations can be solved not only to find loop currents but branch currents as well.

2.11. Mesh Analysis Using Matrix Form

Consider the network of Fig. 2.52, which contains resistances and independent voltage sources and has three meshes. Let the three mesh currents be designated as I_1, I_2 and I_3 and all the three may be assumed to flow in the clockwise direction for obtaining symmetry in mesh equations.

Applying KVL to mesh (i), we have

$$E_1 -I_1R_1 -R_3 (I_1 -I_3) -R_2 (I_1 -I_2) = 0$$

or $(R_1 + R_2 + R_3) I_1 -R_2I_2 -R_3I_3 = E_1$...**(i)**

Similarly, from mesh (ii), we have

$$E_2 -R_2 (I_2 -I_1) -R_5 (I_2 -I_3) -I_2R_4 = 0$$

or $-R_2I_1 + (R_2 + R_4 + R_5) I_2 -R_5I_3 = E_2$...**(ii)**

Applying KVL to mesh (iii), we have

$$E_3 -I_3R_7 -R_5 (I_3 -I_2) -R_3 (I_3 -I_1) -I_3 R_6 = 0$$

or $-R_3I_1 -R_5I_2 + (R_3 + R_5 + R_6 + R_7) I_3 = E_3$...**(iii)**

It should be noted that signs of different items in the above three equations have been so changed as to make the items containing self resistances positive (please see further).

The matrix equivalent of the above three equations is

$$\begin{bmatrix} + (R_1 + R_2 + R_3) & -R_2 & -R_3 \\ -R_2 & + (R_2 + R_4 + R_5) & -R_5 \\ -R_3 & -R_5 & + (R_3 + R_5 + R_6 + R_7) \end{bmatrix} \begin{bmatrix} I_1 \\ I_2 \\ I_3 \end{bmatrix} = \begin{bmatrix} E_1 \\ E_2 \\ E_3 \end{bmatrix}$$

It would be seen that the first item is the first row *i.e.* $(R_1 + R_2 + R_3)$ represents the self resistance of mesh (i) which equals the sum of all resistance in mesh (i). Similarly, the second item in the first row represents the mutual resistance between meshes (i) and (ii) *i.e.* the sum of the resistances common to mesh (i) and (ii). Similarly, the third item in the first row represents the mutual-resistance of the mesh (i) and mesh (iii).

The item E_1 , in general, represents the algebraic sum of the voltages of all the voltage sources acting around mesh (i). Similar is the case with E_2 and E_3 . The sign of the *e.m.f.*s is the same as discussed in Art. 2.3 *i.e.* while going along the current, if we pass from negative to the positive terminal of a battery, then its *e.m.f.* is taken positive. If it is the other way around, then battery *e.m.f.* is taken negative.

In general, let

R_{11} = self-resistance of mesh (i)

R_{22} = self-resistance of mesh (ii) *i.e.* sum of all resistances in mesh (ii)

R_{33} = Self-resistance of mesh (iii) *i.e.* sum of all resistances in mesh (iii)

$R_{12} = R_{21} = -[\text{Sum of all the resistances common to meshes (i) and (ii)}]$ *

$R_{23} = R_{32} = -[\text{Sum of all the resistances common to meshes (ii) and (iii)}]$ *

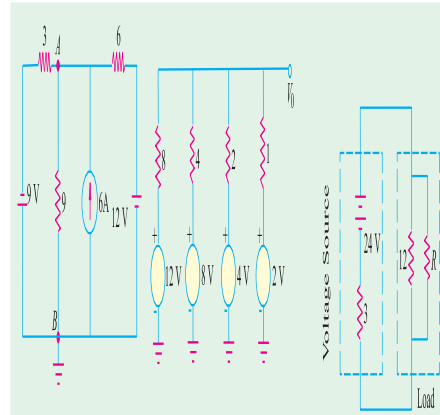

Fig. 2.52

* Although, it is easier to take all loop currents in one direction (Usually clockwise), the choice of direction for any loop current is arbitrary and may be chosen independently of the direction of the other loop currents.

$$R_{31} = R_{13} = -[\text{Sum of all the resistances common to meshes (i) and (iii)}]^*$$

Using these symbols, the generalized form of the above matrix equivalent can be written as

$$\begin{bmatrix} R_{11} & R_{12} & R_{13} \\ R_{21} & R_{22} & R_{23} \\ R_{31} & R_{32} & R_{33} \end{bmatrix} \begin{bmatrix} I_1 \\ I_2 \\ I_3 \end{bmatrix} = \begin{bmatrix} E_1 \\ E_2 \\ E_3 \end{bmatrix}$$

If there are m independent meshes in any linear network, then the mesh equations can be written in the matrix form as under :

$$\begin{bmatrix} R_{11} & R_{12} & R_{13} & \dots & R_{1m} \\ R_{21} & R_{22} & R_{23} & \dots & R_{2m} \\ \dots & \dots & \dots & \dots & \dots \\ \dots & \dots & \dots & \dots & \dots \\ R_{31} & R_{32} & R_{33} & \dots & R_{3m} \end{bmatrix} \begin{bmatrix} I_1 \\ I_2 \\ \dots \\ \dots \\ I_m \end{bmatrix} = \begin{bmatrix} E_1 \\ E_2 \\ \dots \\ \dots \\ E_m \end{bmatrix}$$

The above equations can be written in a more compact form as $[R_m][I_m] = [E_m]$. It is known as Ohm's law in matrix form.

In the end, it may be pointed out that the directions of mesh currents can be selected arbitrarily. If we assume each mesh current to flow in the clockwise direction, then

(i) All self-resistances will always be positive and (ii) all mutual resistances will always be negative. We will adapt this sign convention in the solved examples to follow.

The above main advantage of the generalized form of all mesh equations is that they can be easily remembered because of their symmetry. Moreover, for any given network, these can be written by inspection and then solved by the use of determinants. It eliminates the tedium of deriving simultaneous equations.

Example. 2.30. Write the impedance matrix of the network shown in Fig. 2.53 and find the value of current I_3 . (Network Analysis A.M.I.E. Sec. B.W. 1980)

Solution. Different items of the mesh-resistance matrix $[R_m]$ are as under :

$$R_{11} = 1 + 3 + 2 = 6 \Omega; R_{22} = 2 + 1 + 4 = 7 \Omega; R_{33} = 3 + 2 + 1 = 6 \Omega;$$

$$R_{12} = R_{21} = -2 \Omega; R_{23} = R_{32} = -1 \Omega; R_{13} = R_{31} = -3 \Omega;$$

$$E_1 = +5 \text{ V}; E_2 = 0; E_3 = 0.$$

The mesh equations in the matrix form are

$$\begin{bmatrix} R_{11} & R_{12} & R_{13} \\ R_{21} & R_{22} & R_{23} \\ R_{31} & R_{32} & R_{33} \end{bmatrix} \begin{bmatrix} I_1 \\ I_2 \\ I_3 \end{bmatrix} = \begin{bmatrix} E_1 \\ E_2 \\ E_3 \end{bmatrix} \text{ or } \begin{bmatrix} 6 & -2 & -3 \\ -2 & 7 & -1 \\ -3 & -1 & 6 \end{bmatrix} \begin{bmatrix} I_1 \\ I_2 \\ I_3 \end{bmatrix} = \begin{bmatrix} 5 \\ 0 \\ 0 \end{bmatrix}$$

$$\Delta = \begin{vmatrix} 6 & -2 & -3 \\ -2 & 7 & -1 \\ -3 & -1 & 6 \end{vmatrix} = 6(42 - 1) + 2(-12 - 3) - 3(2 + 21) = 147$$

$$\Delta_3 = \begin{vmatrix} 6 & -2 & 5 \\ -2 & 7 & 0 \\ -3 & -1 & 0 \end{vmatrix} = 6 + 2(5) - 3(-35) = 121$$

$$I_3 = \Delta_3 / \Delta = \frac{121}{147} = 0.823 \text{ A}$$

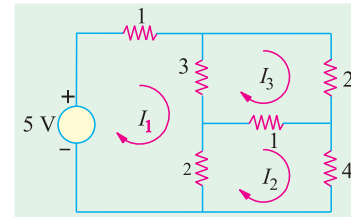

Fig. 2.53

* In general, if the two currents through the common resistance flow in the same direction, then the mutual resistance is taken as negative. One the other hand, if the two currents flow in the same direction, mutual resistance is taken as positive.

Example 2.31. Determine the current supplied by each battery in the circuit shown in Fig. 2.54. (Electrical Engg. Aligarh Univ.)

Solution. Since there are three meshes, let the three loop currents be shown in Fig. 2.51.

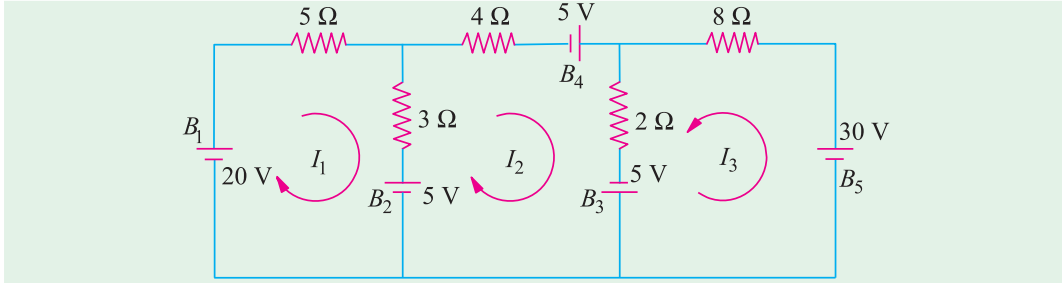

Fig. 2.54

For loop 1 we get

$$20 - 5I_1 - 3(I_1 - I_2) - 5 = 0 \quad \text{or} \quad 8I_1 - 3I_2 = 15 \quad \dots(i)$$

For loop 2 we have

$$-4I_2 + 5 - 2(I_2 - I_3) + 5 + 5 - 3(I_2 - I_1) = 0 \quad \text{or} \quad 3I_1 - 9I_2 + 2I_3 = -15 \quad \dots(ii)$$

Similarly, for loop 3, we get

$$-8I_3 - 30 - 5 - 2(I_3 - I_2) = 0 \quad \text{or} \quad 2I_2 - 10I_3 = 35 \quad \dots(iii)$$

Eliminating I_1 from (i) and (ii), we get $63I_2 - 16I_3 = 165 \quad \dots(iv)$

Similarly, for I_2 from (iii) and (iv), we have $I_2 = 542/299 \text{ A}$

From (iv), $I_3 = -1875/598 \text{ A}$

Substituting the value of I_2 in (i), we get $I_1 = 765/299 \text{ A}$

Since I_3 turns out to be negative, actual directions of flow of loop currents are as shown in

Fig. 2.55.

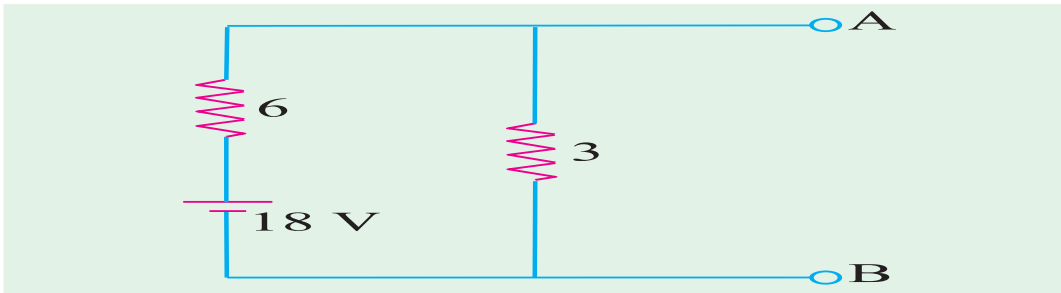

Fig. 2.55

- Discharge current of $B_1 = 765/299 \text{ A}$
- Charging current of $B_2 = I_1 - I_2 = 220/299 \text{ A}$
- Discharge current of $B_3 = I_2 + I_3 = 2965/598 \text{ A}$
- Discharge current of $B_4 = I_2 = 545/299 \text{ A}$; Discharge current of $B_5 = 1875/598 \text{ A}$

Solution by Using Mesh Resistance Matrix.

The different items of the mesh-resistance matrix $[R_m]$ are as under :

$$R_{11} = 5 + 3 = 8 \Omega; R_{22} = 4 + 2 + 3 = 9 \Omega; R_{33} = 8 + 2 = 10 \Omega$$

$$R_{12} = R_{21} = -3 \Omega; R_{13} = R_{31} = 0; R_{23} = R_{32} = -2 \Omega$$

$$E_1 = \text{algebraic sum of the voltages around mesh (i)} = 20 - 5 = 15 \text{ V}$$

$$E_2 = 5 + 5 + 5 = 15 \text{ V}; E_3 = -30 - 5 = -35 \text{ V}$$

Hence, the mesh equations in the matrix form are

$$\begin{bmatrix} R_{11} & R_{12} & R_{13} \\ R_{21} & R_{22} & R_{23} \\ R_{31} & R_{32} & R_{33} \end{bmatrix} \begin{bmatrix} I_1 \\ I_2 \\ I_3 \end{bmatrix} = \begin{bmatrix} E_1 \\ E_2 \\ E_3 \end{bmatrix} \text{ or } \begin{bmatrix} 8 & -3 & 0 \\ -3 & 9 & -2 \\ 0 & -2 & 10 \end{bmatrix} \begin{bmatrix} I_1 \\ I_2 \\ I_3 \end{bmatrix} = \begin{bmatrix} 15 \\ 15 \\ -35 \end{bmatrix}$$

$$\Delta = \begin{vmatrix} 8 & -3 & 0 \\ -3 & 9 & -2 \\ 0 & -2 & 10 \end{vmatrix} = 8(90 - 4) + 3(-30) = 598$$

$$\Delta_1 = \begin{vmatrix} 15 & -3 & 0 \\ 15 & 9 & -2 \\ -35 & -2 & 10 \end{vmatrix} = 15(90 - 4) - 15(-30) - 35(6) = 1530$$

$$\Delta_2 = \begin{vmatrix} 8 & 15 & 0 \\ -3 & 15 & -2 \\ 0 & -35 & 10 \end{vmatrix} = 8(150 - 70) + 3(150 + 0) = 1090$$

$$\Delta_3 = \begin{vmatrix} 8 & -3 & 15 \\ -3 & 9 & 15 \\ 0 & -2 & -35 \end{vmatrix} = 8(-315 + 30) + 3(105 + 30) = -1875$$

$$I_1 = \frac{\Delta_1}{\Delta} = \frac{1530}{598} = \frac{765}{299} \text{ A}; I_2 = \frac{\Delta_2}{\Delta} = \frac{1090}{598} = \frac{545}{299} \text{ A}; I_3 = \frac{\Delta_3}{\Delta} = \frac{-1875}{598} \text{ A}$$

Example 2.32. Determine the current in the 4-Ω branch in the circuit shown in Fig. 2.56.

(Elect. Technology, Nagpur Univ.)

Solution. The three loop currents are as shown in Fig. 2.53 (b).

For loop 1, we have

$$-1(I_1 - I_2) - 3(I_1 - I_3) - 4I_1 + 24 = 0 \quad \text{or} \quad 8I_1 - I_2 - 3I_3 = 24 \quad \dots(i)$$

For loop 2, we have

$$12 - 2I_2 - 12(I_2 - I_3) - 1(I_2 - I_1) = 0 \quad \text{or} \quad I_1 - 15I_2 + 12I_3 = -12 \quad \dots(ii)$$

Similarly, for loop 3, we get

$$-12(I_3 - I_2) - 2I_3 - 10 - 3(I_3 - I_1) = 0 \quad \text{or} \quad 3I_1 + 12I_2 - 17I_3 = 10 \quad \dots(iii)$$

$$\text{Eliminating } I_2 \text{ from Eq. (i) and (ii) above, we get, } 119I_1 - 57I_3 = 372 \quad \dots(iv)$$

$$\text{Similarly, eliminating } I_2 \text{ from Eq. (ii) and (iii), we get, } 57I_1 - 111I_3 = 6 \quad \dots(v)$$

From (iv) and (v) we have,

$$I_1 = 40,950/9,960 = 4.1 \text{ A}$$

Solution by Determinants

The three equations as found above are

$$8I_1 - I_2 - 3I_3 = 24$$

$$I_1 - 15I_2 + 12I_3 = -12$$

$$3I_1 + 12I_2 - 17I_3 = 10$$

$$\text{Their matrix form is } \begin{bmatrix} 8 & -1 & -3 \\ 1 & -15 & 12 \\ 3 & 12 & -17 \end{bmatrix} \begin{bmatrix} x \\ y \\ z \end{bmatrix} = \begin{bmatrix} 24 \\ -12 \\ 10 \end{bmatrix}$$

$$\Delta = \begin{vmatrix} 8 & -1 & -3 \\ 1 & -15 & 12 \\ 3 & 12 & -17 \end{vmatrix} = 664, \quad \Delta_1 = \begin{vmatrix} 24 & -1 & -3 \\ -12 & -15 & 12 \\ 10 & 12 & -17 \end{vmatrix} = 2730$$

$$\therefore I_1 = \Delta_1/\Delta = 2730/664 = 4.1 \text{ A}$$

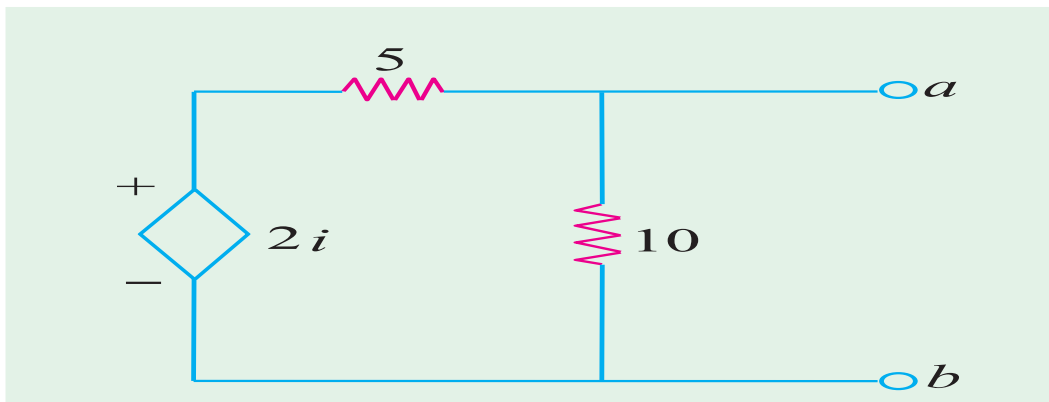

Fig. 2.56

Solution by Using Mesh Resistance Matrix

For the network of Fig. 2.53 (b), values of self resistances, mutual resistances and e.m.f.'s can be written by more inspection of Fig. 2.53.

$$R_{11} = 3 + 1 + 4 = 8 \Omega; R_{22} = 2 + 12 + 1 = 15 \Omega; R_{33} = 2 + 3 + 12 = 17 \Omega$$

$$R_{12} = R_{21} = -1; R_{23} = R_{32} = -12; R_{13} = R_{31} = -3$$

$$E_1 = 24 \text{ V}; E_2 = 12 \text{ V}; E_3 = -10 \text{ V}$$

The matrix form of the above three equations can be written by inspection of the given network as under :-

$$\begin{bmatrix} R_{11} & R_{12} & R_{13} \\ R_{21} & R_{22} & R_{23} \\ R_{31} & R_{32} & R_{33} \end{bmatrix} \begin{bmatrix} I_1 \\ I_2 \\ I_3 \end{bmatrix} = \begin{bmatrix} E_1 \\ E_2 \\ E_3 \end{bmatrix} \text{ or } \begin{bmatrix} 8 & -1 & -3 \\ -1 & 15 & -12 \\ -3 & -12 & 17 \end{bmatrix} \begin{bmatrix} I_1 \\ I_2 \\ I_3 \end{bmatrix} = \begin{bmatrix} 24 \\ 12 \\ -10 \end{bmatrix}$$

$$\Delta = 8(255 - 144) + 1(-17 - 36) - 3(12 + 45) = 664$$

$$\Delta_1 = \begin{bmatrix} 24 & -1 & -3 \\ 12 & 15 & -12 \\ -10 & -12 & 17 \end{bmatrix} = 24(255 - 144) - 12(-17 - 36) - 10(12 + 45) = 2730$$

$$\therefore I_1 = \frac{-1}{664} \frac{2730}{664} = 4.1 \text{ A}$$

It is the same answer as found above.

Tutorial Problems No. 2.2

- Find the ammeter current in Fig. 2.57 by using loop analysis.

[1/7 A] (Network Theory Indore Univ. 1981)

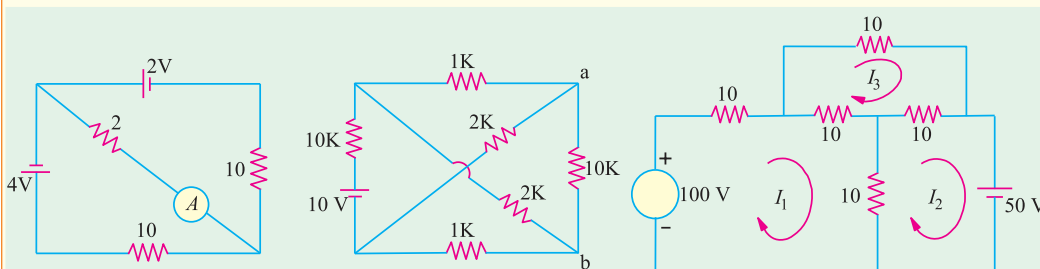

Fig. 2.57

Fig. 2.58

Fig. 2.59

2. Using mesh analysis, determine the voltage across the 10 kΩ resistor at terminals *a-b* of the circuit shown in Fig. 2.58. [2.65 V] (Elect. Technology, Indore Univ.)

3. Apply loop current method to find loop currents I_1 , I_2 and I_3 in the circuit of Fig. 2.59.

$$[I_1 = 3.75 \text{ A}, I_2 = 0, I_3 = 1.25 \text{ A}]$$

2.12. Nodal Analysis With Sources

The node-equation method is based directly on Kirchhoff's current law unlike loop-current method which is based on Kirchhoff's voltage law. However, like loop current method, nodal method also

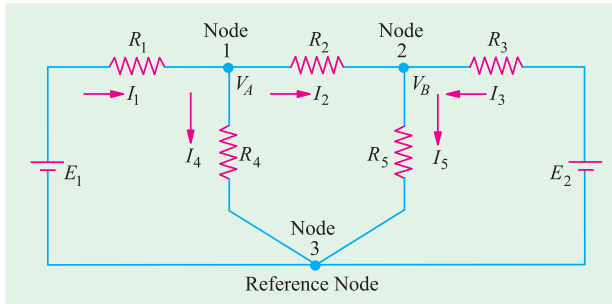

Fig. 2.60

has the advantage that a minimum number of equations need be written to determine the unknown quantities. Moreover, it is particularly suited for networks having many parallel circuits with common ground connected such as electronic circuits.

For the application of this method, every junction in the network where three or more branches meet is regarded a node. One of these is regarded as the

reference node or datum node or zero-potential node. Hence the number of simultaneous equations to be solved becomes $(n - 1)$ where n is the number of independent nodes. These node equations often become simplified if all voltage sources are converted into current sources (Art. 2.12).

(i) First Case

Consider the circuit of Fig. 2.60 which has three nodes. One of these *i.e.* node 3 has been taken in as the reference node. V_A represents the potential of node 1 with reference to the datum node 3. Similarly, V_B is the potential difference between node 2 and node 3. Let the current directions which have been chosen arbitrary be as shown.

For node 1, the following current equation can be written with the help of KCL.

$$I_1 = I_4 + I_2$$

$$\text{Now } I_1 R_1 = E_1 - V_A \quad \therefore I_1 = (E_1 - V_A)/R_1 \quad \dots(i)$$

$$\text{Obviously, } I_4 = V_A/R_4 \quad \text{Also, } I_2 R_2 = V_A - V_B \quad (\because V_A > V_B)$$

$$\therefore I_2 = (V_A - V_B)/R_2$$

Substituting these values in Eq. (i) above, we get,

$$\frac{E_1 - V_A}{R_1} = \frac{V_A}{R_4} + \frac{V_A - V_B}{R_2}$$

Simplifying the above, we have.

$$V_A \left(\frac{1}{R_1} + \frac{1}{R_2} + \frac{1}{R_4} \right) - \frac{V_B}{R_2} - \frac{E_1}{R_1} = 0 \quad \dots(ii)$$

The current equation for node 2 is $I_5 = I_2 + I_3$

$$\text{or } \frac{V_B}{R_5} = \frac{V_A - V_B}{R_2} + \frac{E_2 - V_B}{R_3} \quad \dots(iii)$$

$$\text{or } V_B \left(\frac{1}{R_2} + \frac{1}{R_3} + \frac{1}{R_5} \right) - \frac{V_A}{R_2} - \frac{E_2}{R_3} = 0 \quad \dots(iv)$$

Though the above nodal equations (ii) and (iii) seem to be complicated, they employ a very simple and systematic arrangement of terms which can be written simply by inspection. Eq. (ii) at node 1 is represented by

1. The product of node potential V_A and $(1/R_1 + 1/R_2 + 1/R_4)$ i.e. the sum of the reciprocals of the branch resistance connected to this node.
2. **Minus** the ratio of adjacent potential V_B and the interconnecting resistance R_2 .
3. **Minus** ratio of adjacent battery (or generator) voltage E_1 and interconnecting resistance R_1 .
4. All the above set to zero.

Same is the case with Eq. (iii) which applies to node 2.

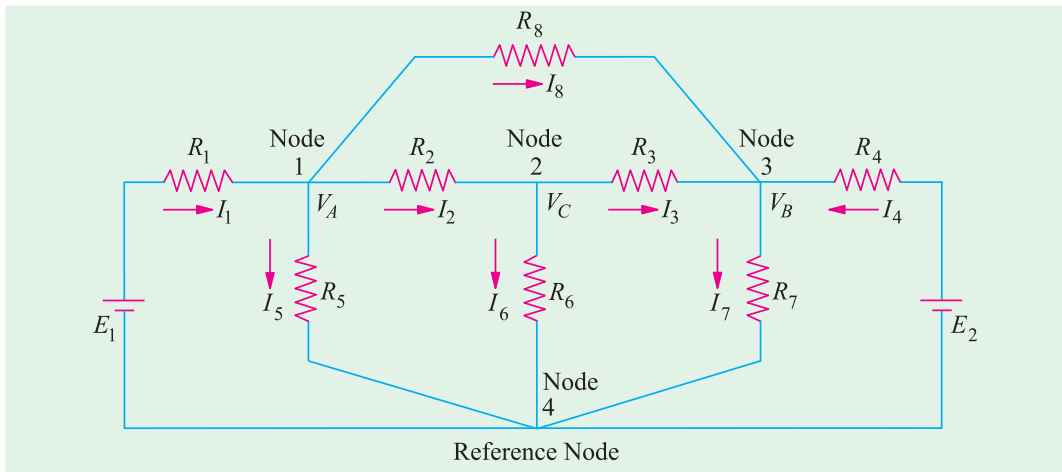

Fig. 2.61

Using conductances instead of resistances, the above two equations may be written as

$$V_A (G_1 + G_2 + G_4) - V_B G_2 - E_1 G_1 = 0 \quad \dots(iv)$$

$$V_B (G_2 + G_3 + G_5) - V_A G_2 - E_2 G_3 = 0 \quad \dots(v)$$

To emphasize the procedure given above, consider the circuit of Fig. 2.61.

The three node equations are
$$V_A \left(\frac{1}{R_1} + \frac{1}{R_2} + \frac{1}{R_5} + \frac{1}{R_8} \right) - \frac{V_C}{R_2} - \frac{V_B}{R_8} - \frac{E_1}{R_1} = 0 \quad (\text{node 1})$$

$$V_C \left(\frac{1}{R_2} + \frac{1}{R_3} + \frac{1}{R_6} \right) - \frac{V_A}{R_2} - \frac{V_B}{R_3} = 0 \quad (\text{node 2})$$

$$V_B \left(\frac{1}{R_3} + \frac{1}{R_4} + \frac{1}{R_7} + \frac{1}{R_8} \right) - \frac{V_C}{R_3} - \frac{V_A}{R_8} - \frac{E_2}{R_4} = 0 \quad (\text{node 3})$$

After finding different node voltages, various currents can be calculated by using Ohm's law.

(ii) Second Case

Now, consider the case when a third battery of e.m.f. E_3 is connected between nodes 1 and 2 as shown in Fig. 2.62.

It must be noted that as we travel from node 1 to node 2, we go from the $-ve$ terminal of E_3 to its $+ve$ terminal. Hence, according to the sign convention given in Art. 2.3, E_3 must be taken as *positive*. However, if we travel from node 2 to node 1, we go from the $+ve$ to the $-ve$ terminal

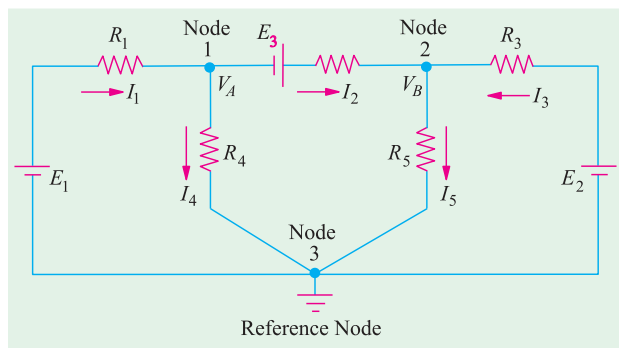

Fig. 2.62

of E_3 . Hence, *when viewed from node 2, E_3 is taken negative.*

For node 1

$$\begin{aligned}
 & I_1 - I_4 - I_2 = 0 \text{ or } I_1 = I_4 + I_2 \text{ -as per KCL} \\
 \text{Now,} & I_1 = \frac{E_1 - V_A}{R_1}; I_2 = \frac{V_A + E_3 - V_B}{R_2}; I_4 = \frac{V_A}{R_4} \\
 \therefore & \frac{E_1 - V_A}{R_1} = \frac{V_A}{R_4} + \frac{V_A + E_3 - V_B}{R_2} \\
 \text{or} & V_A \left(\frac{1}{R_1} + \frac{1}{R_2} + \frac{1}{R_3} \right) - \frac{E_1}{R_1} - \frac{V_B}{R_2} + \frac{E_2}{R_2} = 0 \quad \dots(i)
 \end{aligned}$$

It is exactly the same expression as given under the First Case discussed above except for the additional term involving E_3 . This additional term is taken as $+E_3/R_2$ (and not as $-E_3/R_2$) because this third battery is so connected that when viewed from mode 1, it represents a *rise* in voltage. Had it been connected the other way around, the additional term would have been taken as $-E_3/R_2$.

For node 2

$$\begin{aligned}
 & I_2 + I_3 - I_5 = 0 \text{ or } I_2 + I_3 = I_5 \text{ -as per KCL} \\
 \text{Now, as before,} & I_2 = \frac{V_A + E_3 - V_B}{R_2}, I_3 = \frac{E_2 - V_B}{R_3}, I_5 = \frac{V_B}{R_5} \\
 \therefore & \frac{V_A + E_3 - V_B}{R_2} + \frac{E_2 - V_B}{R_3} = \frac{V_B}{R_5} \\
 \text{On simplifying, we get} & V_B \left(\frac{1}{R_2} + \frac{1}{R_3} + \frac{1}{R_5} \right) - \frac{E_2}{R_3} - \frac{V_A}{R_2} - \frac{E_3}{R_2} = 0 \quad \dots(ii)
 \end{aligned}$$

As seen, the additional terms is $-E_3/R_2$ (and not $+E_3/R_2$) because as viewed from this node, E_3 represents a *fall* in potential.

It is worth repeating that the additional term in the above Eq. (i) and (ii) can be either $+E_3/R_2$ or $-E_3/R_2$ depending on whether it represents a rise or fall of potential when viewed from *the node under consideration.*

Example 2.33. Using Node voltage method, find the current in the 3Ω resistance for the network shown in Fig. 2.63. (Elect. Tech. Osmania Univ.)

Solution. As shown in the figure node 2 has been taken as the reference node. We will now find the value of node voltage V_1 . Using the technique developed in Art. 2.10, we get

$$V_1 \left(\frac{1}{5} + \frac{1}{2} + \frac{1}{2} \right) - \frac{4}{2} - \left(\frac{4+2}{5} \right) = 0$$

The reason for adding the two battery voltages of 2 V and 4 V is because they are connected in additive series. Simplifying above, we get $V_1 = 8/3$ V. The current flowing through the 3Ω resistance towards node 1 is $= \frac{6 - (8/3)}{(3+2)} = \frac{2}{3}$ A

Alternatively

$$\begin{aligned}
 \frac{6 - V_1}{5} + \frac{4}{2} - \frac{V_1}{2} &= 0 \\
 12 - 2V_1 + 20 - 5V_1 &= 0
 \end{aligned}$$

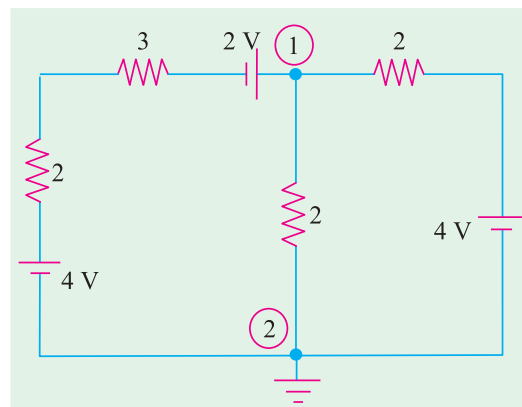

Fig. 2.63

$$7V_1 = 32$$

$$\text{Also } \frac{6 - V_1}{5} + \frac{4 - V_1}{2} = \frac{V_1}{2}$$

$$12 - 2V_1 + 20 - 5V_1 = 5V_1$$

$$12V_1 = 32; V_1 = 8/3$$

Example 2.34. Frame and solve the node equations of the network of Fig. 2.64. Hence, find the total power consumed by the passive elements of the network. (Elect. Circuits Nagpur Univ.)

Solution. The node equation for node 1 is

$$V_1 \left(1 + 1 + \frac{1}{0.5} \right) - \frac{V_2}{0.5} - \frac{15}{1} = 0$$

or $4V_1 - 2V_2 = 15$... (i)

Similarly, for node 2, we have

$$V_1 \left(1 + \frac{1}{2} + \frac{1}{0.5} \right) - \frac{V_2}{0.5} - \frac{20}{1} = 0$$

or $4V_1 - 7V_2 = -40$... (ii)

∴ $V_2 = 11$ volt and $V_1 = 37/4$ volt
Now,

$$I_1 = \frac{15 - 37/4}{1} = \frac{23}{4} \text{ A} = 5.75 \text{ A}; I_2 = \frac{11 - 37/4}{0.5} = 3.5 \text{ A}$$

$$I_4 = 5.75 + 3.5 = 9.25 \text{ A}; I_3 = \frac{20 - 11}{1} = 9 \text{ A}; I_5 = 9 - 3.5 = 5.5 \text{ A}$$

The passive elements of the network are its five resistances. Total power consumed by them is $= 5.75^2 \times 1 + 3.5^2 \times 0.5 + 9^2 \times 1 + 9.25^2 \times 1 + 5.5^2 \times 2 = 266.25$

Example 2.35. Find the branch currents in the circuit of Fig. 2.65 by using (i) nodal analysis and (ii) loop analysis.

Solution. (i) Nodal Method

The equation for node A can be written by inspection as explained in Art. 2-12.

$$V_A \left(\frac{1}{R_1} + \frac{1}{R_2} + \frac{1}{R_4} \right) - \frac{E_1}{R_1} - \frac{V_B}{R_2} + \frac{E_3}{R_2} = 0$$

Substituting the given data, we get,

$$V_A \left(\frac{1}{6} + \frac{1}{2} + \frac{1}{3} \right) - \frac{6}{6} - \frac{V_B}{2} + \frac{5}{2} = 0 \quad \text{or } 2V_A - V_B = -3 \quad \dots (i)$$

For node B, the equation becomes

$$V_B \left(\frac{1}{R_2} + \frac{1}{R_3} + \frac{1}{R_5} \right) - \frac{E_2}{R_3} - \frac{V_A}{R_2} - \frac{E_3}{R_2} = 0$$

$$\therefore V_B \left(\frac{1}{2} + \frac{1}{4} + \frac{1}{4} \right) - \frac{10}{4} - \frac{V_A}{2} - \frac{5}{2} = 0 \quad \therefore V_B - \frac{V_A}{2} = 5 \quad \dots (ii)$$

From Eq. (i) and (ii), we get,

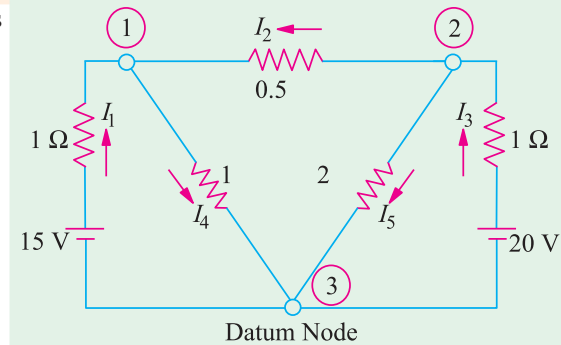

Fig. 2.64

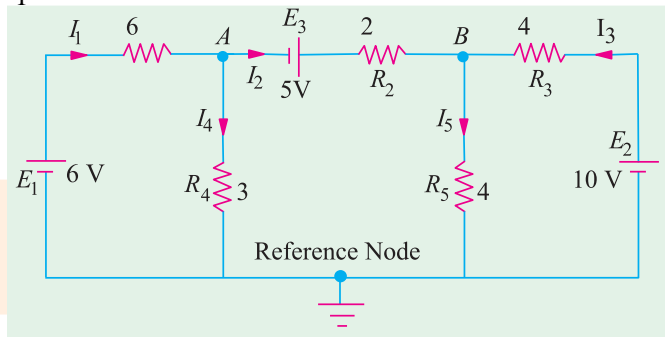

Fig. 2.65

$$V_A = \frac{4}{3} V, V_B = \frac{17}{3} V$$

$$I_1 = \frac{E_1 V_A}{R_1} = \frac{6 \cdot 4/3}{6} = \frac{7}{9} \text{ A}$$

$$I_2 = \frac{V_A E_3 V_B}{R_2} = \frac{(4/3) \cdot 5 \cdot (17/3)}{2} = \frac{1}{3} \text{ A}$$

$$I_3 = \frac{E_2 V_B}{R_3} = \frac{10 \cdot 17/3}{4} = \frac{13}{12} \text{ A}$$

$$I_4 = \frac{V_A}{R_4} = \frac{4/3}{3} = \frac{4}{9} \text{ A}, I_5 = \frac{V_B}{R_5} = \frac{17/3}{4} = \frac{17}{12} \text{ A}$$

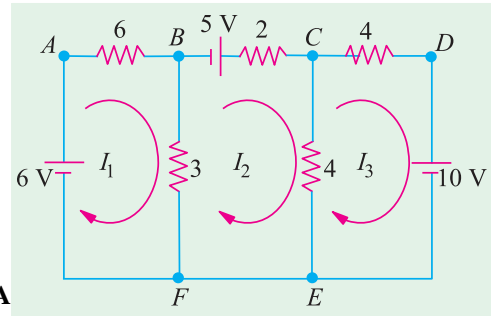

Fig. 2.66

(ii) Loop Current Method

Let the direction of flow of the three loop currents be as shown in Fig. 2.66.

Loop ABFA :

$$-6I_1 - 3(I_1 - I_2) + 6 = 0$$

or

$$3I_1 - I_2 = 2$$

...**(i)****Loop BCEFB :**

$$+5 - 2I_2 - 4(I_2 - I_3) - 3(I_2 - I_1) = 0$$

or

$$3I_1 - 9I_2 + 4I_3 = -5$$

...**(ii)****Loop CDEC :**

$$-4I_3 - 10 - 4(I_3 - I_2) = 0 \text{ or } 2I_2 - 4I_3 = 5$$

...**(iii)**

The matrix form of the above three simultaneous equations is

$$\begin{bmatrix} 3 & -1 & 0 \\ 3 & -9 & 4 \\ 0 & 2 & -4 \end{bmatrix} \begin{bmatrix} x \\ y \\ z \end{bmatrix} = \begin{bmatrix} 2 \\ -5 \\ 5 \end{bmatrix}; \Delta = \begin{vmatrix} 3 & -1 & 0 \\ 3 & -9 & 4 \\ 0 & 2 & -4 \end{vmatrix} = 84 - 12 - 0 = 72$$

$$\Delta_1 = \begin{vmatrix} 2 & 1 & 0 \\ -5 & -9 & 4 \\ 5 & 2 & -4 \end{vmatrix} = 56; \Delta_2 = \begin{vmatrix} 3 & 2 & 0 \\ 3 & -5 & 4 \\ 0 & 5 & -4 \end{vmatrix} = 24; \Delta_3 = \begin{vmatrix} 3 & -1 & 2 \\ 3 & -9 & -5 \\ 0 & 2 & 5 \end{vmatrix} = -78$$

$$\therefore I_1 = \Delta_1/\Delta = 56/72 = 7/9 \text{ A}; I_2 = \Delta_2/\Delta = 24/72 = 1/3 \text{ A}$$

$$I_3 = \Delta_3/\Delta = -78/72 = -13/12 \text{ A}$$

The negative sign of I_3 shows that it is flowing in a direction opposite to that shown in Fig. 2.64 *i.e.* it flows in the CCW direction. The actual directions are as shown in Fig. 2.67.

The various branch currents are as under :

$$I_{AB} = I_1 = \frac{7}{9} \text{ A}; I_{BF} = I_1 - I_2 = \frac{7}{9} - \frac{1}{3} = \frac{4}{9} \text{ A}$$

$$I_{BC} = I_2 = \frac{1}{3} \text{ A}; I_{CE} = I_2 - I_3 = \frac{1}{3} - \left(-\frac{13}{12}\right) = \frac{13}{12} \text{ A}$$

$$I_{DC} = I_3 = \frac{13}{12} \text{ A}$$

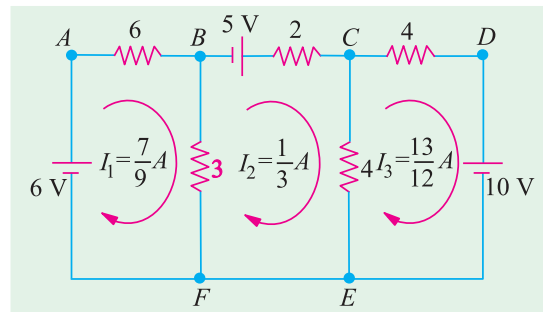

Fig. 2.67

Solution by Using Mesh Resistance Matrix

From inspection of Fig. 2.67, we have

$$R_{11} = 9; R_{22} = 9; R_{33} = 8$$

$$R_{12} = R_{21} = -3 \Omega; R_{23} = R_{32} = -4 \Omega; R_{13} = R_{31} = 0 \Omega$$

$$E_1 = 6 \text{ V}; E_2 = 5 \text{ V}; E_3 = -10 \text{ V}$$

$$\begin{bmatrix} R_{11} & R_{12} & R_{13} \\ R_{21} & R_{22} & R_{23} \\ R_{31} & R_{32} & R_{33} \end{bmatrix} \begin{bmatrix} I_1 \\ I_2 \\ I_3 \end{bmatrix} = \begin{bmatrix} E_1 \\ E_2 \\ E_3 \end{bmatrix} \text{ or } \begin{bmatrix} 9 & -3 & 0 \\ -3 & 9 & -4 \\ 0 & -4 & 8 \end{bmatrix} \begin{bmatrix} I_1 \\ I_2 \\ I_3 \end{bmatrix} = \begin{bmatrix} 6 \\ 5 \\ -10 \end{bmatrix}$$

$$\Delta = \begin{vmatrix} 9 & -3 & 0 \\ -3 & 9 & -4 \\ 0 & -4 & 8 \end{vmatrix} = 9(72 - 16) + 3(-24) = 432$$

$$\Delta_1 = \begin{vmatrix} 6 & -3 & 0 \\ 5 & 9 & -4 \\ -10 & -4 & 8 \end{vmatrix} = 6(72 - 16) - 5(-24) - 10(12) = 336$$

$$\Delta_2 = \begin{vmatrix} 9 & 6 & 0 \\ -3 & 5 & -4 \\ 0 & -10 & 8 \end{vmatrix} = 9(40 - 40) + 3(48) = 144$$

$$\Delta_3 = \begin{vmatrix} 9 & -3 & 6 \\ -3 & 9 & 5 \\ 0 & -4 & -10 \end{vmatrix} = 9(-90 + 90) - 3(30 + 24) = -468$$

$$I_1 = \Delta_1/\Delta = 336/432 = 7/9 \text{ A}$$

$$I_2 = \Delta_2/\Delta = 144/432 = 1/3 \text{ A}$$

$$I_3 = \Delta_3/\Delta = -468/432 = -13/12 \text{ A}$$

These are the same values as found above.

2.13. Nodal Analysis with Current Sources

Consider the network of Fig. 2.68 (a) which has two current sources and three nodes out of which 1 and 2 are independent ones whereas No. 3 is the reference node.

The given circuit has been redrawn for ease of understanding and is shown in Fig. 2.68 (b). The current directions have been taken on the assumption that

1. both V_1 and V_2 are positive with respect to the reference node. That is why their respective currents flow from nodes 1 and 2 to node 3.
2. V_1 is positive with respect to V_2 because current has been shown flowing from node 1 to node 2.

A positive result will confirm our assumption whereas a negative one will indicate that actual direction is opposite to that assumed.

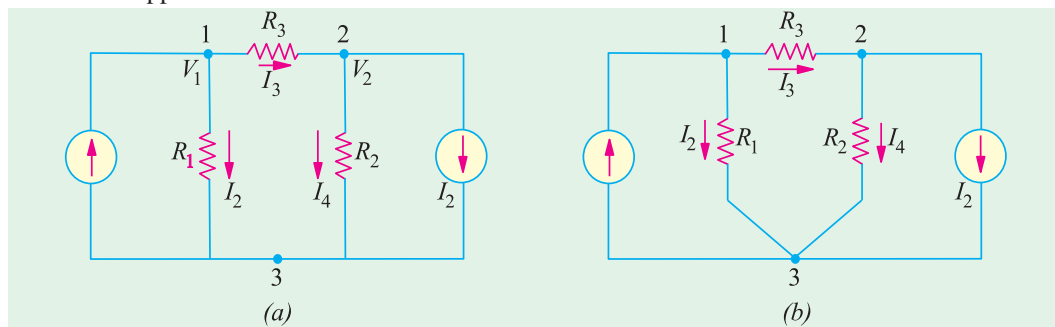

Fig. 2.68

We will now apply *KCL* to each node and use Ohm's law to express branch currents in terms of node voltages and resistances.

Node 1

$$I_1 - I_2 - I_3 = 0 \quad \text{or} \quad I_1 = I_2 + I_3$$

$$\begin{aligned} \text{Now} \quad I_2 &= \frac{V_1}{R_1} \quad \text{and} \quad I_3 = \frac{V_1 - V_2}{R_3} \\ \therefore \quad I_1 &= \frac{V_1}{R_1} + \frac{V_1 - V_2}{R_3} \quad \text{or} \quad V_1 \left(\frac{1}{R_1} + \frac{1}{R_3} \right) - \frac{V_2}{R_3} = I_1 \quad \dots(i) \end{aligned}$$

Node 2

$$\begin{aligned} I_3 - I_2 - I_4 &= 0 \quad \text{or} \quad I_3 = I_2 + I_4 \\ \text{Now,} \quad I_4 &= \frac{V_2}{R_2} \quad \text{and} \quad I_3 = \frac{V_1 - V_2}{-R_3} \quad \text{--as before} \\ \therefore \quad \frac{V_1 - V_2}{R_3} &= I_2 + \frac{V_2}{R_2} \quad \text{or} \quad V_2 \left(\frac{1}{R_2} + \frac{1}{R_3} \right) - \frac{V_1}{R_3} = -I_1 \quad \dots(ii) \end{aligned}$$

The above two equations can also be written by simple inspection. For example, Eq. (i) is represented by

1. **product** of potential V_1 and $(1/R_1 + 1/R_3)$ i.e. sum of the reciprocals of the branch resistances connected to this node.

2. **minus** the ratio of adjoining potential V_2 and the interconnecting resistance R_3 .

3. all the above equated to the current supplied by the current source connected to this node.

This current is taken *positive* if flowing *into* the node and *negative* if flowing *out* of it (as per sign convention of Art. 2.3). Same remarks apply to Eq. (ii) where I_2 has been taken negative because it flows *away* from node 2.

In terms of branch conductances, the above two equations can be put as

$$V_1 (G_1 + G_3) - V_2 G_3 = I_1 \quad \text{and} \quad V_2 (G_2 + G_3) - V_1 G_3 = -I_2$$

Example 2.36. Use nodal analysis method to find currents in the various resistors of the circuit shown in Fig. 2.69 (a).

Solution. The given circuit is redrawn in Fig. 2.66 (b) with its different nodes marked 1, 2, 3 and 4, the last one being taken as the reference or datum node. The different node-voltage equations are as under :

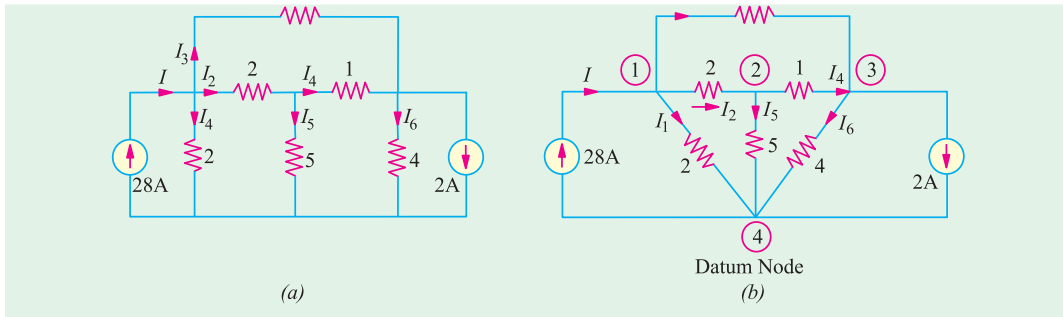

Fig. 2.69

$$\begin{aligned} \text{Node 1} \quad V_1 \left(\frac{1}{2} + \frac{1}{2} + \frac{1}{10} \right) - \frac{V_2}{2} - \frac{V_3}{10} &= 8 \\ \text{or} \quad 11V_1 - 5V_2 - V_3 - 280 &= 0 \quad \dots(i) \end{aligned}$$

$$\begin{aligned} \text{Node 2} \quad V_2 \left(\frac{1}{2} + \frac{1}{5} + 1 \right) - \frac{V_1}{2} - \frac{V_3}{1} &= 0 \\ \text{or} \quad 5V_1 - 17V_2 + 10V_3 &= 0 \quad \dots(ii) \end{aligned}$$

$$\text{Node 3} \quad V_3 \left(\frac{1}{4} + 1 + \frac{1}{10} \right) - \frac{V_2}{1} - \frac{V_1}{10} = -2$$

or $V_1 + 10 V_2 - 13.5 V_3 - 20 = 0$

...(iii)

The matrix form of the above three equations is

$$\begin{bmatrix} 11 & -5 & -1 \\ 5 & -17 & 10 \\ 1 & 10 & -13.5 \end{bmatrix} \begin{bmatrix} x \\ y \\ z \end{bmatrix} = \begin{bmatrix} 280 \\ 0 \\ 20 \end{bmatrix}$$

$$\Delta = \begin{vmatrix} 11 & -5 & -1 \\ 5 & -17 & 10 \\ 1 & 10 & -13.5 \end{vmatrix} = 1424.5 - 387.5 - 67 = 970$$

$$\Delta_1 = \begin{vmatrix} 280 & -5 & -1 \\ 0 & -17 & 10 \\ 20 & 10 & -13.5 \end{vmatrix} = 34,920, \quad \Delta_2 = \begin{vmatrix} 11 & 280 & -1 \\ 5 & 0 & 10 \\ 1 & 20 & -13.5 \end{vmatrix} = 19,400$$

$$\Delta_3 = \begin{vmatrix} 11 & -5 & 280 \\ 5 & -17 & 0 \\ 1 & 10 & 20 \end{vmatrix} = 15,520$$

$$V_1 = \frac{\Delta_1}{\Delta} = \frac{34,920}{970} = 36 \text{ V}, \quad V_2 = \frac{\Delta_2}{\Delta} = \frac{19,400}{970} = 20 \text{ V}, \quad V_3 = \frac{\Delta_3}{\Delta} = \frac{15,520}{970} = 16 \text{ V}$$

It is obvious that all nodes are at a higher potential with respect to the datum node. The various currents shown in Fig. 2.69 (b) can now be found easily.

$$I_1 = V_1/2 = 36/2 = 18 \text{ A}$$

$$I_2 = (V_1 - V_2)/2 = (36 - 20)/2 = 8 \text{ A}$$

$$I_3 = (V_1 - V_3)/10 = (36 - 16)/10 = 2 \text{ A}$$

It is seen that total current, as expected, is $18 + 8 + 2 = 28 \text{ A}$

$$I_4 = (V_2 - V_3)/1 = (20 - 16)/1 = 4 \text{ A}$$

$$I_5 = V_2/5 = 20/5 = 4 \text{ A}, \quad I_6 = V_3/4 = 16/4 = 4 \text{ A}$$

Example 2.37. Using nodal analysis, find the different branch currents in the circuit of Fig. 2.70 (a). All branch conductances are in siemens (i.e. mho).

Solution. Let the various branch currents be as shown in Fig. 2.70 (b). Using the procedure detailed in Art. 2.11, we have

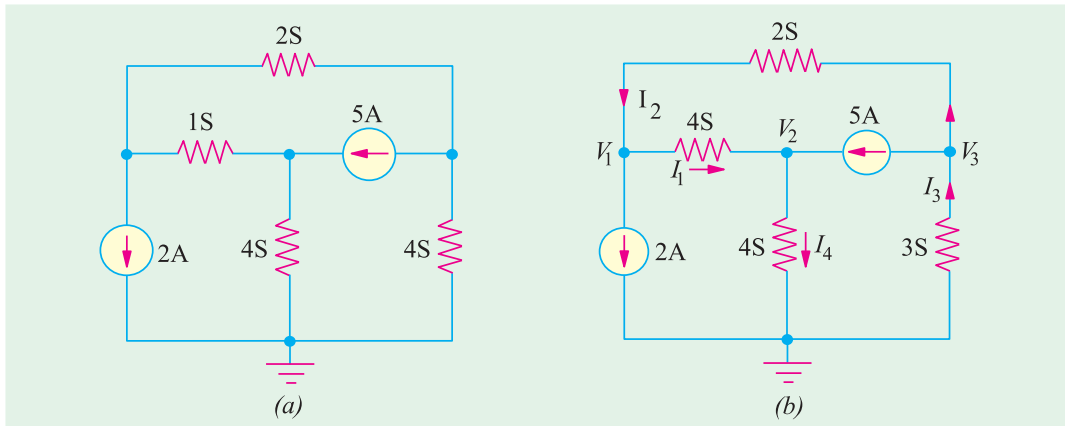

Fig. 2.70

First Node

$$V_1 (1 + 2) - V_2 \times 1 - V_3 \times 2 = -2 \quad \text{or} \quad 3V_1 - V_2 - 2V_3 = -2 \quad \dots(i)$$

Second Node

$$V_2 (1 + 4) - V_1 \times 1 = 5 \quad \text{or} \quad V_1 - 5V_2 = -5 \quad \dots(ii)$$

Third Node

$$V_3 (2 + 3) - V_1 \times 2 = -5 \quad \text{or} \quad 2V_1 - 5V_3 = 5 \quad \dots(iii)$$

Solving for the different voltages, we have

$$V_1 = -\frac{3}{2} \text{ V}, V_2 = \frac{7}{10} \text{ V and } V_3 = -\frac{8}{5} \text{ V}$$

$$I_1 = (V_1 - V_2) \times 1 = (-1.5 - 0.7) \times 1 = -2.2 \text{ A}$$

$$I_2 = (V_3 - V_1) \times 2 = [-1.6 - (-1.5)] \times 2 = -0.2 \text{ A}$$

$$I_4 = V_2 \times 4 = 4 \times (7/10) = 2.8 \text{ A}$$

$$I_3 = 2 + 2.8 = 4.8 \text{ A}$$

As seen, I_1 and I_2 flow in directions opposite to those originally assumed (Fig. 2.71).

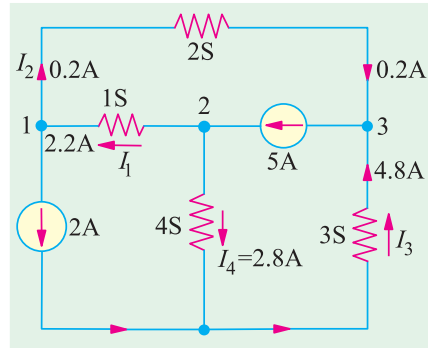

Fig. 2.71

Example 2.38. Find the current I in Fig. 2.72 (a) by changing the two voltage sources into their equivalent current sources and then using Nodal method. All resistances are in ohms.

Solution. The two voltage sources have been converted into their equivalent current sources in Fig. 2.72 (b). The circuit has been redrawn as shown in Fig. 2.72 (c) where node No. 4 has been

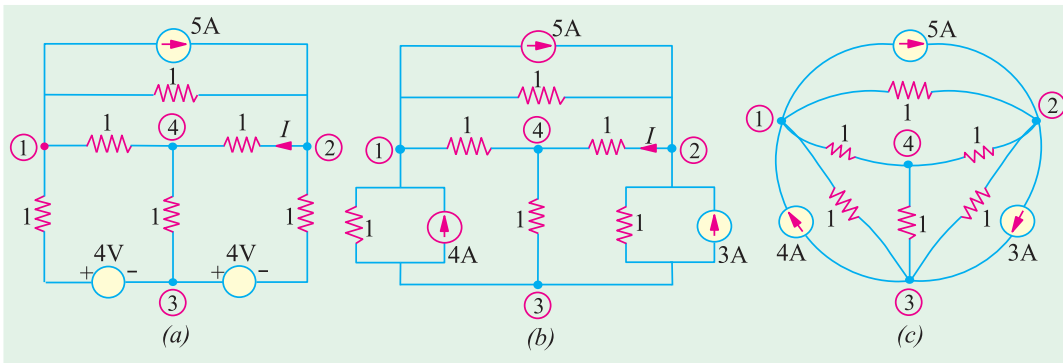

Fig. 2.72

taken as the reference node or common ground for all other nodes. We will apply *KCL* to the three nodes and taken currents coming towards the nodes as positive and those going away from them as negative. For example, current going away from node No. 1 is $(V_1 - V_2)/1$ and hence would be taken as negative. Since 4 A current is coming towards node No. 1, it would be taken as positive but 5 A current would be taken as negative.

$$\text{Node 1 : } -\frac{(V_1 - 0)}{1} - \frac{(V_1 - V_2)}{1} - \frac{(V_1 - V_3)}{1} - 5 + 4 = 0$$

$$\text{or } 3V_1 - V_2 - V_3 = -1 \quad \dots(i)$$

$$\text{Node 2 : } -\frac{(V_2 - 0)}{1} - \frac{(V_2 - V_3)}{1} - \frac{(V_2 - V_1)}{1} + 5 - 3 = 0$$

$$\text{or } V_1 - 3V_2 + V_3 = -2 \quad \dots(ii)$$

$$\text{Node 3 : } -\frac{(V_3 - 0)}{1} - \frac{(V_3 - V_1)}{1} - \frac{(V_3 - V_2)}{1} - 4 + 3 = 0$$

$$\text{or } V_1 + V_2 - 3V_3 = 1 \quad \dots(iii)$$

The matrix form of the above three equations is

$$\begin{bmatrix} 3 & -1 & -1 \\ 1 & -3 & 1 \\ 1 & 1 & -3 \end{bmatrix} \begin{bmatrix} V_1 \\ V_2 \\ V_3 \end{bmatrix} = \begin{bmatrix} -1 \\ -2 \\ 1 \end{bmatrix}$$

$$\Delta = \begin{vmatrix} 3 & -1 & -1 \\ 1 & -3 & 1 \\ 1 & 1 & -3 \end{vmatrix} = 3(9-1) - 1(3+1) + 1(-1-3) = 16$$

$$\Delta_2 = \begin{vmatrix} 3 & -1 & -1 \\ 1 & -2 & 1 \\ 1 & 1 & -3 \end{vmatrix} = 3(6-1) - 1(3+1) + 1(-1-2) = 8$$

$$\therefore V_2 = \Delta_2/\Delta = 8/16 = 0.5 \text{ V}$$

$$\therefore I = V_2/1 = 0.5 \text{ A}$$

Example 2.39. Use Nodal analysis to determine the value of current i in the network of Fig. 2.73.

Solution. We will apply KCL to the two nodes 1 and 2. Equating the incoming currents at node 1 to the outgoing currents, we have

$$6 = \frac{V_1 - V_2}{4} + \frac{V_1}{8} + 3i$$

As seen, $i = V_1/8$. Hence, the above equation becomes

$$6 = \frac{V_1 - V_2}{4} + \frac{V_1}{8} + 3 \frac{V_1}{8}$$

$$\text{or } 3V_1 - V_2 = 24$$

Similarly, applying KCL to node No. 2, we get

$$\frac{V_1 - V_2}{4} + 3i = \frac{V_2}{6} \text{ or } \frac{V_1 - V_2}{4} + 3 \frac{V_1}{8} = \frac{V_2}{6} \text{ or } 3V_1 = 2V_2$$

From the above two equations, we get

$$V_1 = 16 \text{ V} \quad \therefore i = 16/8 = 2 \text{ A.}$$

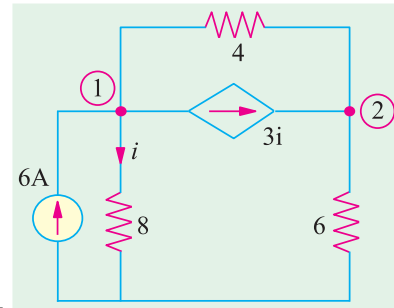

Fig. 2.73

Example 2.40. Using Nodal analysis, find the node voltages V_1 and V_2 in Fig. 2.74.

Solution. Applying KCL to node 1, we get

$$8 - 1 - \frac{V_1}{3} - \frac{(V_1 - V_2)}{6} = 0$$

$$\text{or } 3V_1 - V_2 = 42 \quad \dots(i)$$

Similarly, applying KCL to node 2, we get

$$1 + \frac{(V_1 - V_2)}{6} - \frac{V_2}{15} - \frac{V_2}{10} = 0$$

$$\text{or } V_1 - 2V_2 = -6 \quad \dots(ii)$$

Solving for V_1 and V_2 from Eqn. (i) and (ii), we get

$$V_1 = 18 \text{ V and } V_2 = 12 \text{ V.}$$

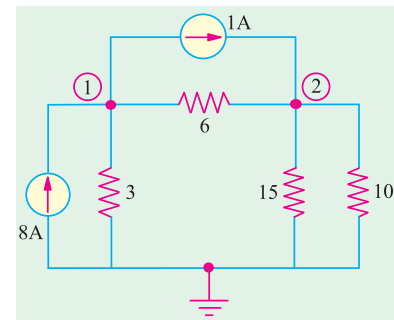

Fig. 2.74

2.14. Source Conversion

A given voltage source with a series resistance can be converted into (or replaced by) and equivalent current source with a parallel resistance. Conversely, a current source with a parallel resistance can be converted into a voltage source with a series resistance. Suppose, we want to convert the voltage source of Fig. 2.75 (a) into an equivalent current source. First, we will find the value of current supplied by the source when a 'short' is put across in terminals A and B as shown in Fig. 2.75 (b). This current is $I = V/R$.

A current source supplying this current I and having the same resistance R connected in *parallel* with it represents the equivalent source. It is shown in Fig. 2.75 (c). Similarly, a current source of I and a parallel resistance R can be converted into a voltage source of voltage $V = IR$ and a resistance

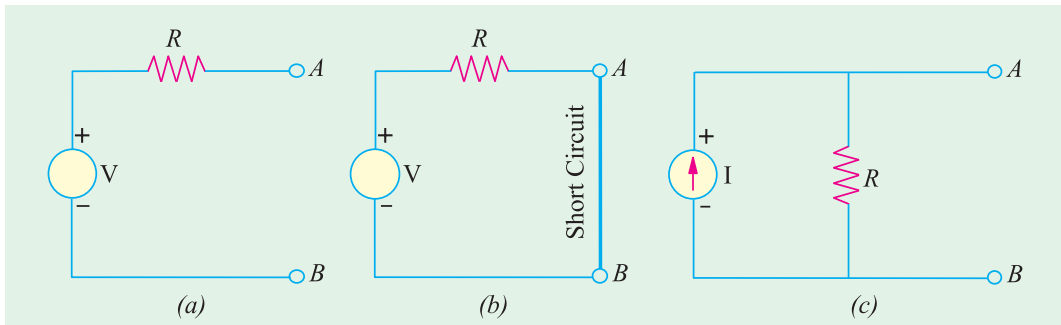

Fig. 2.75

R in series with it. It should be kept in mind that a voltage source-series resistance combination is equivalent to (or replaceable by) a current source-parallel resistance combination if, and only if their

1. respective open-circuit voltages are equal, and
2. respective short-circuit currents are equal.

For example, in Fig. 2.75 (a), voltage across terminals A and B when they are open (*i.e.* open-circuit voltage V_{OC}) is V itself because there is no drop across R . Short-circuit current across $AB = I = V/R$.

Now, take the circuit of Fig. 2.75 (c). The open-circuit voltage across $AB =$ drop across $R = IR = V$. If a short is placed across AB , whole of I passes through it because R is completely shorted out.

Example 2.41. Convert the voltage source of Fig. 2.73 (a) into an equivalent current source.

Solution. As shown in Fig 2.76 (b), current obtained by putting a short across terminals A and B is $10/5 = 2$ A.

Hence, the equivalent current source is as shown in Fig. 2.76 (c).

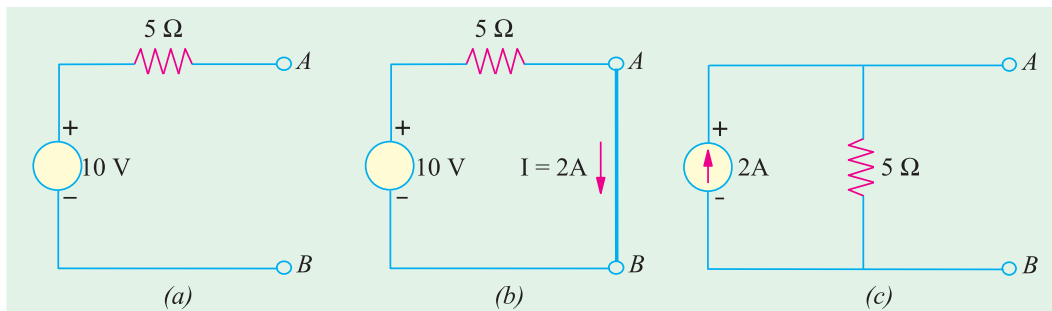

Fig. 2.76

Example 2.42. Find the equivalent voltage source for the current source in Fig. 2.77 (a).

Solution. The open-circuit voltage across terminals A and B in Fig. 2.77 (a) is

$$\begin{aligned} V_{OC} &= \text{drop across } R \\ &= 5 \times 2 = 10 \text{ V} \end{aligned}$$

Hence, voltage source has a voltage of **10 V** and the same resistance of 2Ω through connected in series [Fig. 2.77 (b)].

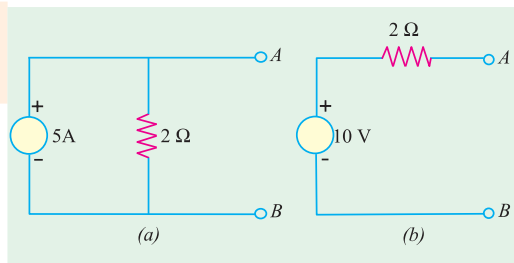

Fig. 2.77

Example 2.43. Use Source Conversion technique to find the load current I in the circuit of Fig. 2.78 (a).

Solution. As shown in Fig. 2.78 (b), 6-V voltage source with a series resistance of $3\ \Omega$ has been converted into an equivalent 2 A current source with $3\ \Omega$ resistance in parallel.

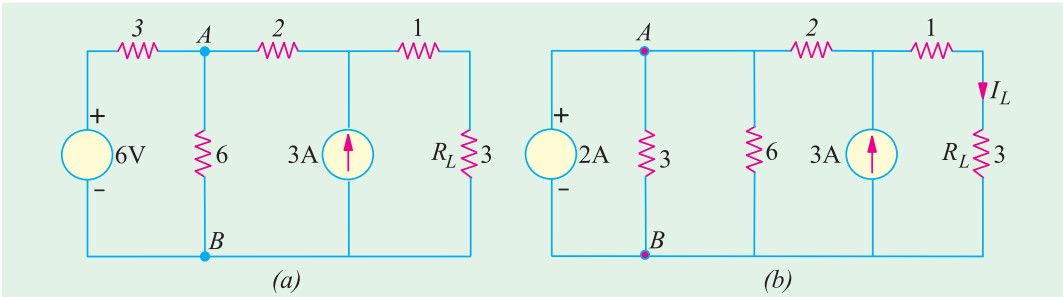

Fig. 2.78

The two parallel resistances of $3\ \Omega$ and $6\ \Omega$ can be combined into a single resistance of $2\ \Omega$ as shown in Fig. 2.79 (a).

The two current sources cannot be combined together because of the $2\ \Omega$ resistance present between points A and C. To remove this hurdle, we convert the 2 A current source into the equivalent 4 V voltage source as shown in Fig. 2.79 (b). Now, this 4 V voltage source with a series resistance of $(2 + 2) = 4\ \Omega$ can again be converted into the equivalent current source as shown in Fig. 2.80 (a). Now, the two current sources can be combined into a single 4-A source as shown in Fig. 2.80 (b).

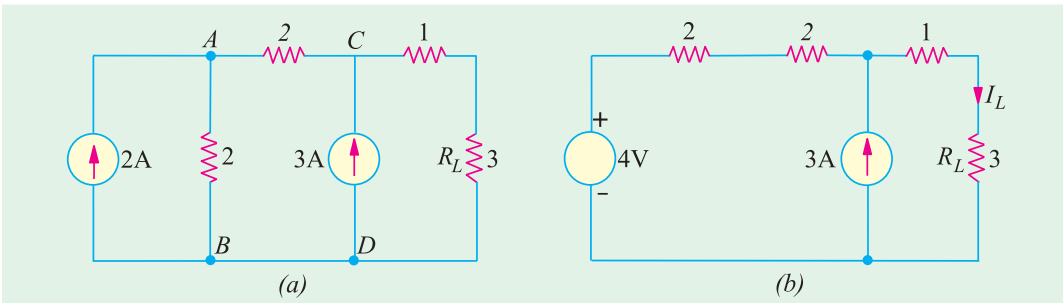

Fig. 2.79

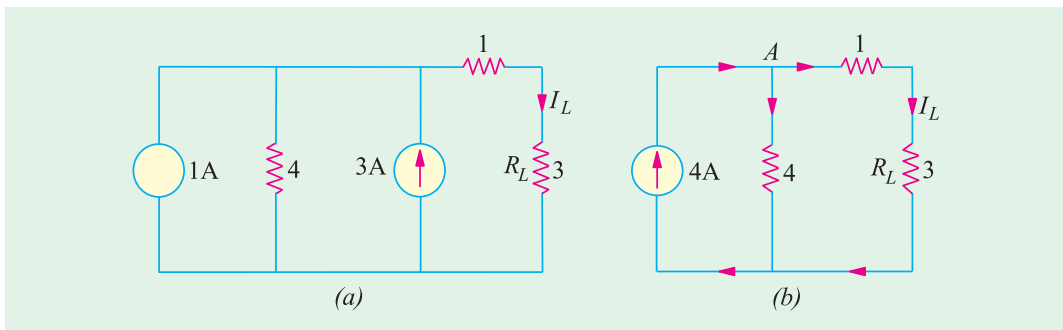

Fig. 2.80

The 4-A current is divided into two equal parts at point A because each of the two parallel paths has a resistance of $4\ \Omega$. Hence $I_1 = 2\ \text{A}$.

Example 2.44. Calculate the direction and magnitude of the current through the $5\ \Omega$ resistor between points A and B of Fig. 2.81 (a) by using nodal voltage method.

Solution. The first thing is to convert the voltage source into the current sources as shown in Fig. 2.81 (b). Next, the two parallel resistances of $4\ \Omega$ each can be combined to give a single resistance of $2\ \Omega$ [Fig. 2.82 (a)]. Let the current directions be as indicated.

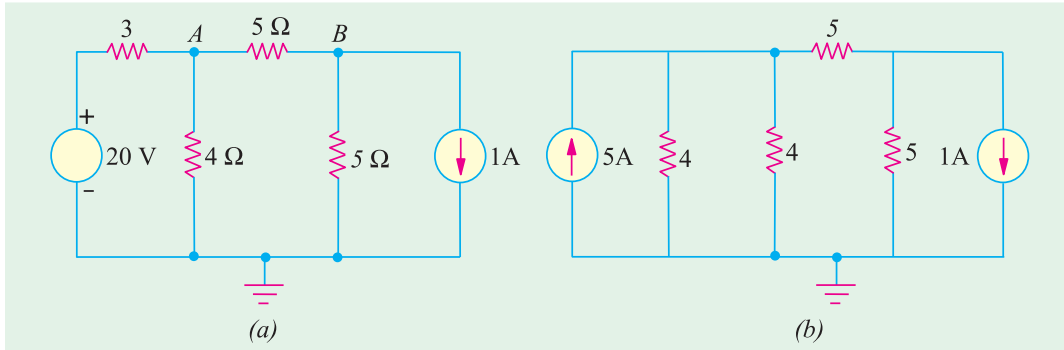

Fig. 2.81

Applying the nodal rule to nodes 1 and 2, we get

Node 1

$$V_1 \left(\frac{1}{2} + \frac{1}{5} \right) - \frac{V_2}{5} = 5 \quad \text{or} \quad 7V_1 - 2V_2 = 50 \quad \dots(i)$$

Node 2

$$V_2 \left(\frac{1}{5} + \frac{1}{5} \right) - \frac{V_1}{5} = -1 \quad \text{or} \quad V_1 - 2V_2 = 5 \quad \dots(ii)$$

Solving for V_1 and V_2 , we get $V_1 = \frac{15}{2}\ \text{V}$ and $V_2 = \frac{5}{4}\ \text{V}$.

$$I_2 = \frac{V_1 - V_2}{5} = \frac{15/2 - 5/4}{5} = \frac{15/2 - 5/4}{5} = \mathbf{1.25\ \text{A}}$$

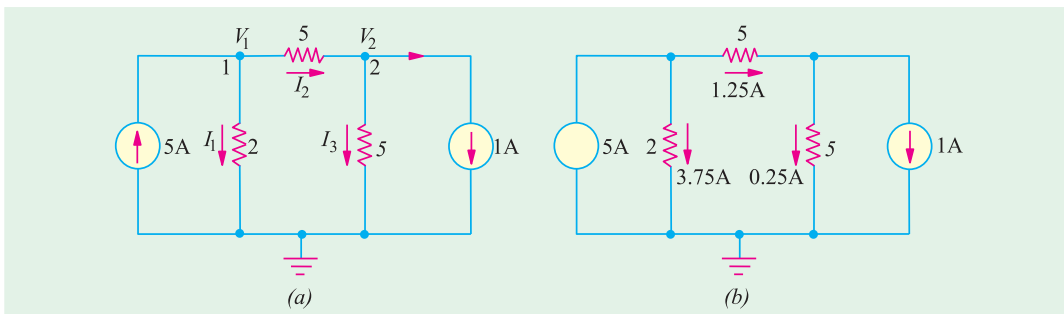

Fig. 2.82

Similarly, $I_1 = V_1/2 = 15/4 = 3.75\ \text{A}$; $I_3 = V_2/5 = 5/20 = 0.25\ \text{A}$.

The actual current distribution becomes as shown in Fig. 2.79 (b).

Example 2.45. Replace the given network by a single current source in parallel with a resistance.

[Bombay University 2001]

Solution. The equivalence is expected for a load connected to the right-side of terminals A and B. In this case, the voltage-source has no resistive element in series. While handling such cases, the 3-ohm resistor has to be kept aside, treating it as an independent and separate loop. This voltage source will circulate a current of $20/3$ amp in the resistor, and will not appear in the calculations.

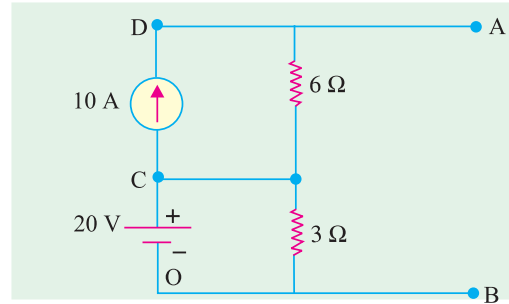

Fig. 2.83 (a)

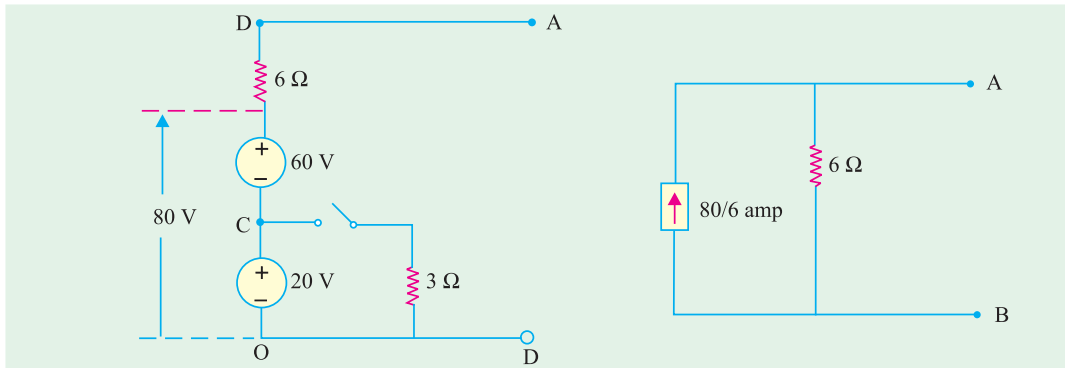

Fig. 2.83 (b)

Fig. 2.83 (c)

This step does not affect the circuit connected to A-B. Further steps are shown in Fig. 2.83 (b) and (c)

Tutorial Problems No. 2.3

1. Using Maxwell's loop current method, calculate the output voltage V_o for the circuits shown in Fig. 2.84. [(a) 4 V (b) $-150/7$ V (c) $V_o = 0$ (d) $V_o = 0$]

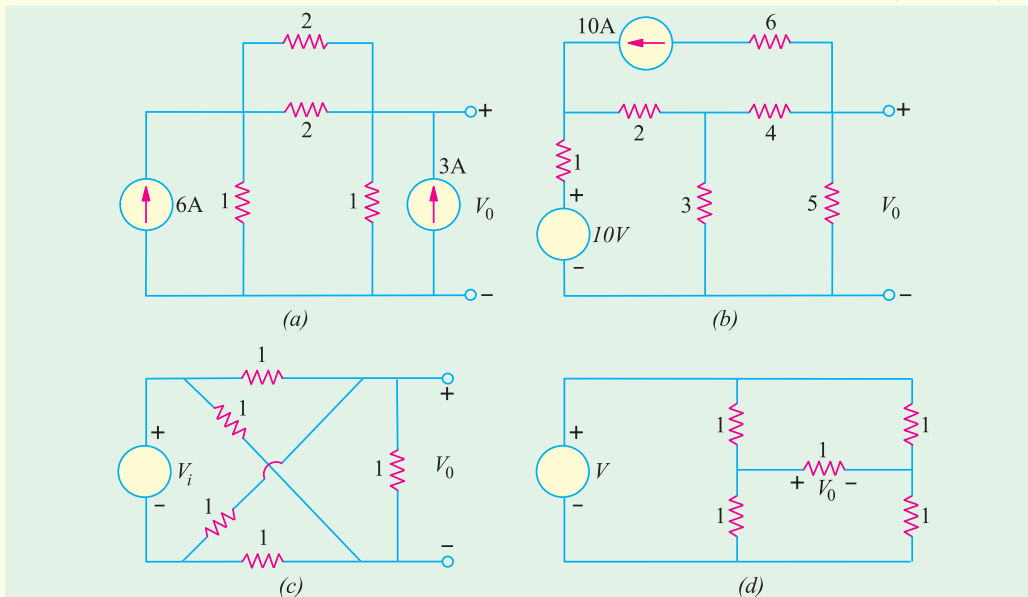

Fig. 2.84

2. Using nodal voltage method, find the magnitude and direction of current I in the network of Fig. 2.85.

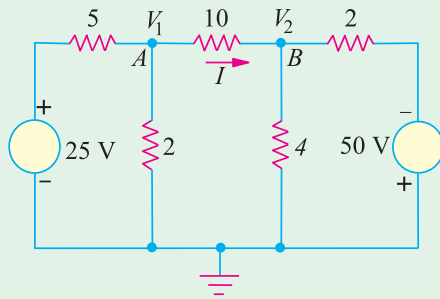

Fig. 2.85

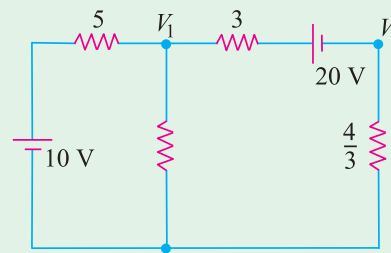
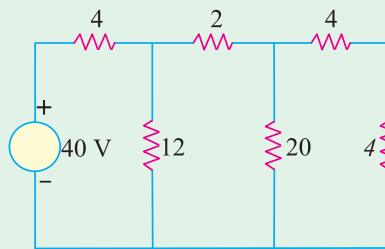
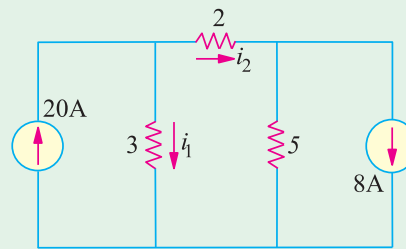

Fig. 2.86

3. By using repeated source transformations, find the value of voltage v in Fig. 2.87 (a). [8 V]



(a)



(b)

Fig. 2.87

4. Use source transformation technique to find the current flowing through the $2\ \Omega$ resistor in Fig. 2.87 (b). [10 A]

5. With the help of nodal analysis, calculate the values of nodal voltages V_1 and V_2 in the circuit of Fig. 2.86. [7.1 V; -3.96 V]

6. Use nodal analysis to find various branch currents in the circuit of Fig. 2.88.

[Hint : Check by source conversion.]

[$I_{ac} = 2\ \text{A}$; $I_{ab} = 5\ \text{A}$, $I_{bc} = 0$]

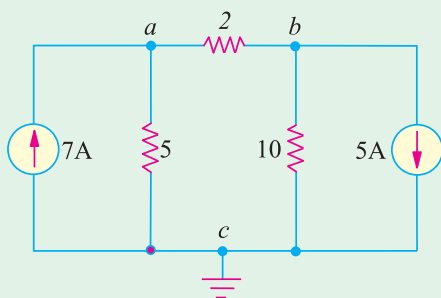

Fig. 2.88

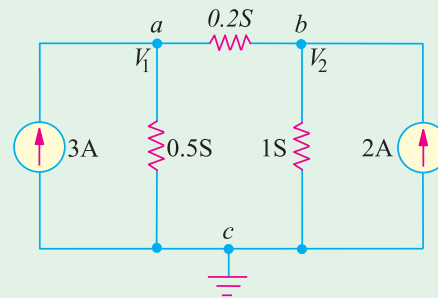

Fig. 2.89

7. With the help of nodal analysis, find V_1 and V_2 and various branch currents in the network of Fig. 2.85. [5 V, 2.5 V; $I_{ac} = 2.5\ \text{A}$; $I_{ab} = 0.5\ \text{A}$; $I_{bc} = 2.5\ \text{A}$]

8. By applying nodal analysis to the circuit of Fig. 2.90, find I_{ab} , I_{bd} and I_{bc} . All resistance values are in ohms. [$I_{ab} = \frac{22}{21}\ \text{A}$, $I_{bd} = \frac{10}{7}\ \text{A}$, $I_{bc} = \frac{-8}{21}\ \text{A}$]

[Hint : It would be helpful to convert resistance into conductances.]

9. Using nodal voltage method, compute the power dissipated in the 9-Ω resistor of Fig. 2.91. [81 W]

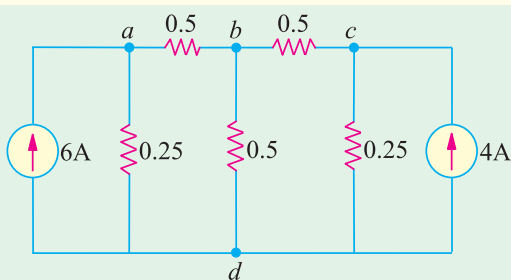

Fig. 2.90

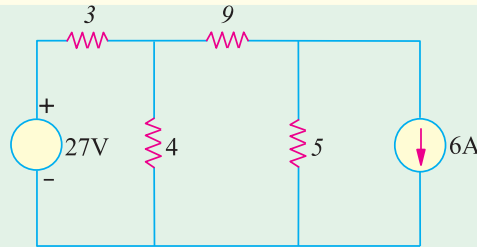

Fig. 2.91

10. Write equilibrium equations for the network in Fig. 2.92 on nodal basis and obtain the voltage V_1 , V_2 and V_3 . All resistors in the network are of 1 Ω [Network Theory and Fields, Madras Univ.]

11. By applying nodal method of network analysis, find current in the 15 Ω resistor of the network shown in Fig. 2.93. [3.5 A] [Elect. Technology-I, Gwalior Univ.]

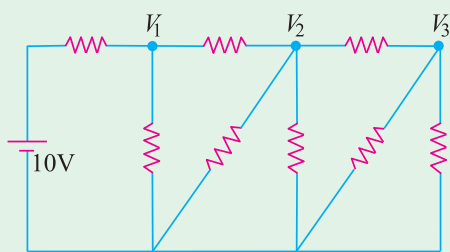

Fig. 2.92

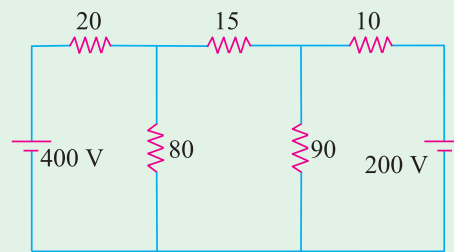

Fig. 2.93

2.15. Ideal Constant-Voltage Source

It is that voltage source (or generator) whose output voltage remains absolutely constant whatever the change in load current. Such a voltage source must possess *zero internal resistance so that internal voltage drop in the source is zero*. In that case, output voltage provided by the source would remain constant *irrespective of the amount of current drawn from it*. In practice, none such ideal constant-voltage source can be obtained. However, smaller the internal resistance r of a voltage source, closer it comes to the ideal sources described above.

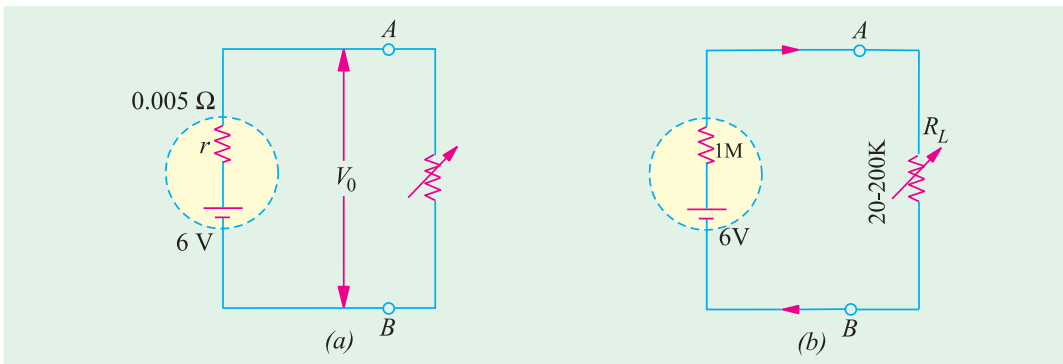

Fig. 2.94

Suppose, a 6-V battery has an internal resistance of 0.005 Ω [Fig. 2.94 (a)]. When it supplies no current *i.e.* it is on no-load, $V_o = 6$ V *i.e.* output voltage provided by it at its output terminals A and B

is 6 V. If load current increases to 100 A, internal drop = $100 \times 0.005 = 0.5$ V. Hence, $V_o = 6 - 0.5 = 5.5$ V.

Obviously an output voltage of 5.5 – 6 V can be considered constant as compared to wide variations in load current from 0 A to 100 A.

2.16. Ideal Constant-Current Source

It is that voltage source whose internal resistance is infinity. In practice, it is approached by a source which possesses very high resistance as compared to that of the external load resistance. As shown in Fig. 2.94 (b), let the 6-V battery or voltage source have an internal resistance of $1 \text{ M}\Omega$ and let the load resistance vary from 20 K to 200 K. The current supplied by the source varies from $6.1/1.02 = 5.9 \mu\text{A}$ to $6/1.2 = 5 \mu\text{A}$. As seen, even when load resistance increases 10 times, current decreases by $0.9 \mu\text{A}$. Hence, the source can be considered, for all practical purposes, to be a constant-current source.

2.17. Superposition Theorem

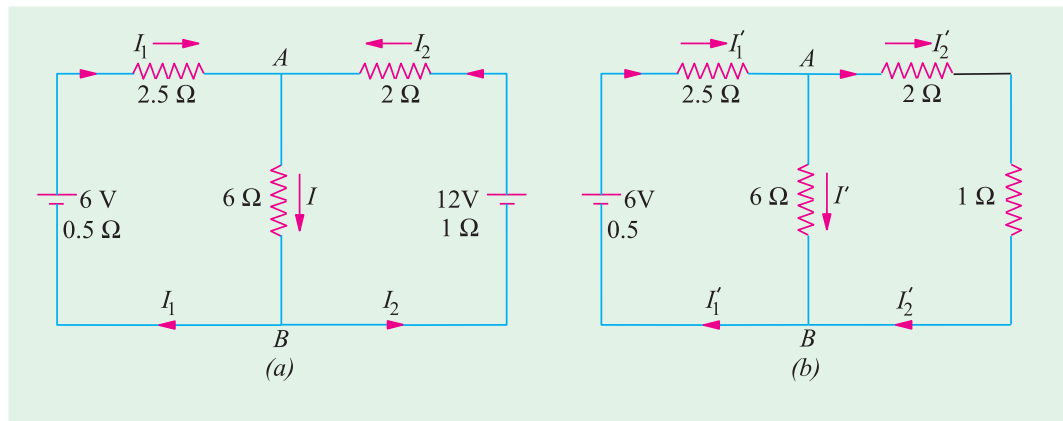

Fig. 2.95

According to this theorem, if there are a number of e.m.f.s. acting simultaneously in any linear bilateral network, then each e.m.f. acts independently of the others *i.e.* as if the other e.m.f.s. did not exist. The value of current in any conductor is the algebraic sum of the currents due to each e.m.f. Similarly, voltage across any conductor is the algebraic sum of the voltages which each e.m.f. would have produced while acting singly. In other words, current in or voltage across, any conductor of the network is obtained by superimposing the currents and voltages due to each e.m.f. in the network. It is important to keep in mind that this theorem is applicable only to **linear** networks where current is

linearly related to voltage as per Ohm's law.

Hence, this theorem may be stated as follows :

In a network of linear resistances containing more than one generator (or source of e.m.f.), the current which flows at any point is the sum of all the currents which would flow at that point if each generator were considered separately and all the other generators replaced for the time being by resistances equal to their internal resistances.

Explanation

In Fig. 2.95 (a) I_1 , I_2 and I represent the values of

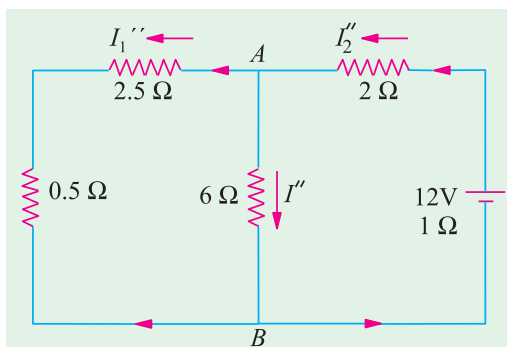

Fig. 2.96

currents which are due to the simultaneous action of the two sources of e.m.f. in the network. In Fig. 2.95 (b) are shown the current values which would have been obtained if left-hand side battery had acted alone. Similarly, Fig. 2.96 represents conditions obtained when right-hand side battery acts alone. By combining the current values of Fig. 2.95 (b) and 2.96 the actual values of Fig. 2.95 (a) can be obtained.

$$\text{Obviously, } I_1 = I_1' - I_1''', I_2 = I_2' - I_2''', I = I' + I''.$$

Example 2.46. In Fig. 2.95 (a) let battery e.m.fs. be 6 V and 12 V, their internal resistances 0.5 Ω and 1 Ω . The values of other resistances are as indicated. Find the different currents flowing in the branches and voltage across 60-ohm resistor.

Solution. In Fig. 2.95 (b), 12-volt battery has been removed though its internal resistance of 1 Ω remains. The various currents can be found by applying Ohm's Law.

It is seen that there are two parallel paths between points A and B, having resistances of 6 Ω and (2 + 1) = 3 Ω

$$\therefore \text{ equivalent resistance} = 3 \parallel 6 = 2 \Omega$$

$$\text{Total resistance} = 0.5 + 2.5 + 2 = 5 \Omega \quad \therefore I_1' = 6/5 = \mathbf{1.2 \text{ A.}}$$

This current divides at point A inversely in the ratio of the resistances of the two parallel paths.

$$\therefore I = 1.2 \times (3/9) = 0.4 \text{ A.} \quad \text{Similarly, } I_2' = 1.2 \times (6/9) = 0.8 \text{ A}$$

In Fig. 2.96, 6 volt battery has been removed but not its internal resistance. The various currents and their directions are as shown.

The equivalent resistance to the left to points A and B is $3 \parallel 6 = 2 \Omega$

$$\therefore \text{ total resistance} = 1 + 2 + 2 = 5 \Omega \quad \therefore I_2''' = 12/5 = 2.4 \text{ A}$$

At point A, this current is divided into two parts,

$$I' = 2.4 \times 3/9 = 0.8 \text{ A, } I_1''' = 2.4 \times 6/9 = 1.6 \text{ A}$$

The actual current values of Fig. 2.95 (a) can be obtained by superposition of these two sets of current values.

$$\therefore I_1 = I_1' - I_1''' = 1.2 - 1.6 = \mathbf{-0.4 \text{ A}} \text{ (it is a charging current)}$$

$$I_2 = I_2' - I_2''' = 0.8 - 2.4 = \mathbf{-1.6 \text{ A}}$$

$$I = I' + I'' = 0.4 + 0.8 = \mathbf{1.2 \text{ A}}$$

Voltage drop across 6-ohm resistor = $6 \times 1.2 = \mathbf{7.2 \text{ V}}$

Example 2.47. By using Superposition Theorem, find the current in resistance R shown in Fig. 2.97 (a)

$$R_1 = 0.005 \Omega, R_2 = 0.004 \Omega, R = 1 \Omega, E_1 = 2.05 \text{ V}, E_2 = 2.15 \text{ V}$$

Internal resistances of cells are negligible. **(Electronic Circuits, Allahabad Univ. 1992)**

Solution. In Fig. 2.97 (b), E_2 has been removed. Resistances of 1 Ω and 0.04 Ω are in parallel across points A and C. $R_{AC} = 1 \parallel 0.04 = 1 \times 0.04/1.04 = 0.038 \Omega$. This resistance is in series with 0.05 Ω . Hence, total resistance offered to battery $E_1 = 0.05 + 0.038 = 0.088 \Omega$. $I = 2.05/0.088 = 23.3 \text{ A}$. Current through 1- Ω resistance, $I_1 = 23.3 \times 0.04/1.04 = 0.896 \text{ A}$ from C to A.

When E_1 is removed, circuit becomes as shown in Fig. 2.97 (c). Combined resistance of paths CBA and CDA is $1 \parallel 0.05 = 1 \times 0.05/1.05 = 0.048 \Omega$. Total resistance offered to E_2 is $= 0.04 + 0.048 = 0.088 \Omega$. Current $I = 2.15/0.088 = 24.4 \text{ A}$. Again, $I_2 = 24.4 \times 0.05/1.05 = 1.16 \text{ A}$.

To current through 1- Ω resistance when both batteries are present

$$= I_1 + I_2 = 0.896 + 1.16 = \mathbf{2.056 \text{ A.}}$$

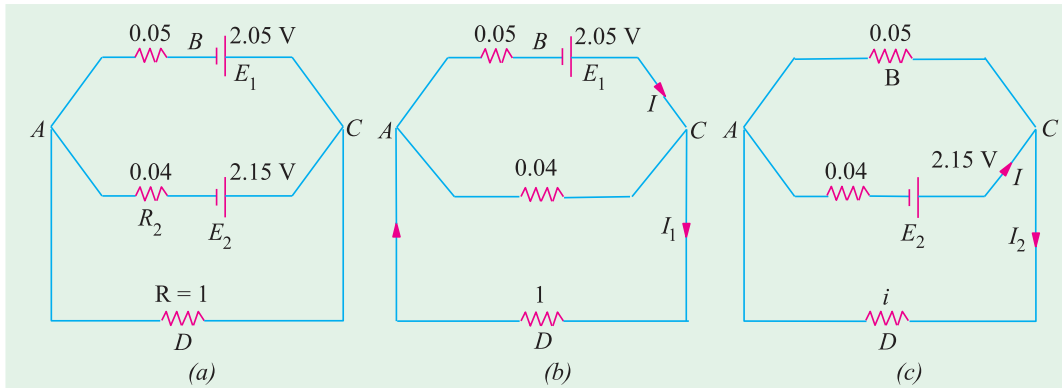

Fig. 2.97

Example 2.48. Use Superposition theorem to find current I in the circuit shown in Fig. 2.98 (a). All resistances are in ohms. (Basic Circuit Analysis Osmania Univ. Jan/Feb 1992)

Solution. In Fig. 2.98 (b), the voltage source has been replaced by a short and the 40 A current sources by an open. Using the current-divider rule, we get $I_1 = 120 \times 50/200 = 30$ A.

In Fig. 2.98 (c), only 40 A current source has been considered. Again, using current-divider rule $I_2 = 40 \times 150/200 = 30$ A.

In Fig. 2.98 (d), only voltage source has been considered. Using Ohm's law,

$$I_3 = 10/200 = 0.05 \text{ A.}$$

Since I_1 and I_2 cancel out, $I = I_3 = 0.005$ A.

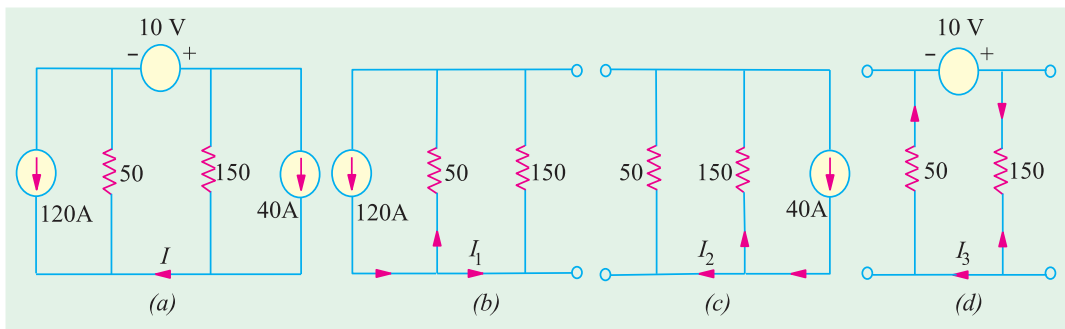

Fig. 2.98

Example 2.49. Use superposition theorem to determine the voltage v in the network of Fig. 2.99(a).

Solution. As seen, there are three independent sources and one dependent source. We will find the value of v produced by each of the three independent sources when acting alone and add the three values to find v . It should be noted that unlike independent source, a dependent source cannot be set to zero *i.e.* it cannot be 'killed' or deactivated.

Let us find the value of v_1 due to 30 V source only. For this purpose we will replace current source by an open circuit and the 20 V source by a short circuit as shown in Fig. 2.99 (b). Applying KCL to node 1, we get

$$\frac{(30 - v_1)}{6} - \frac{v_1}{3} + \frac{(v_1/3 - v_1)}{2} = 0 \quad \text{or} \quad v_1 = 6 \text{ V}$$

Let us now keep 5 A source alive and 'kill' the other two independent sources. Again applying KCL to node 1, we get, from Fig. 2.99 (c).

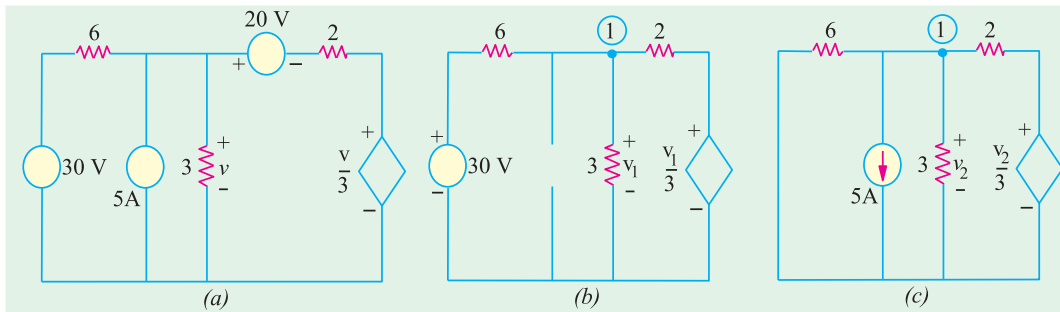

Fig. 2.99

$$\frac{v_2}{6} - 5 - \frac{v_2}{3} + \frac{(v_2/3 - v_2)}{2} = 0 \quad \text{or} \quad v_2 = -6 \text{ V}$$

Let us now ‘kill’ 30 V source and 5 A source and find v_3 due to 20 V source only. The two parallel resistances of 6 Ω and 3 Ω can be combined into a single resistance of 2 Ω. Assuming a circulating current of i and applying KVL to the indicated circuit, we get, from Fig. 2.100.

$$-2i - 20 - 2i - \frac{1}{3}(-2i) = 0 \quad \text{or} \quad i = 6 \text{ A}$$

Hence, according to Ohm’s law, the component of v that corresponds to 20 V source is $v_3 = 2 \times 6 = 12 \text{ V}$. $\therefore v = v_1 + v_2 + v_3 = 6 - 6 + 12 = 12 \text{ V}$.

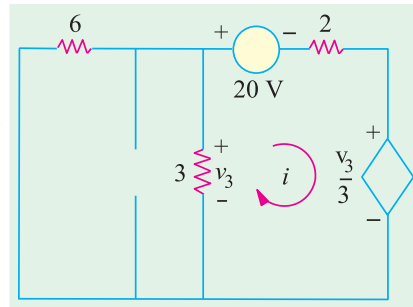

Fig. 2.100

Example 2.50. Using Superposition theorem, find the current through the 40 W resistor of the circuit shown in Fig. 2.101 (a). (F.Y. Engg. Pune Univ. May 1990)

Solution. We will first consider when 50 V battery acts alone and afterwards when 10-V battery is alone in the circuit. When 10-V battery is replaced by short-circuit, the circuit becomes as shown in Fig. 2.101 (b). It will be seen that the right-hand side 5 Ω resistor becomes connected in parallel with 40 Ω resistor giving a combined resistance of $5 \parallel 40 = 4.44 \Omega$ as shown in Fig. 101 (c). This 4.44 Ω resistance is in series with the left-hand side resistor of 5 Ω giving a total resistance of $(5 + 4.44) = 9.44 \Omega$. As seen there are two resistances of 20 Ω and 9.44 Ω connected in parallel. In Fig. 2.101 (c) current $I = 50/9.44 = 5.296 \text{ A}$.

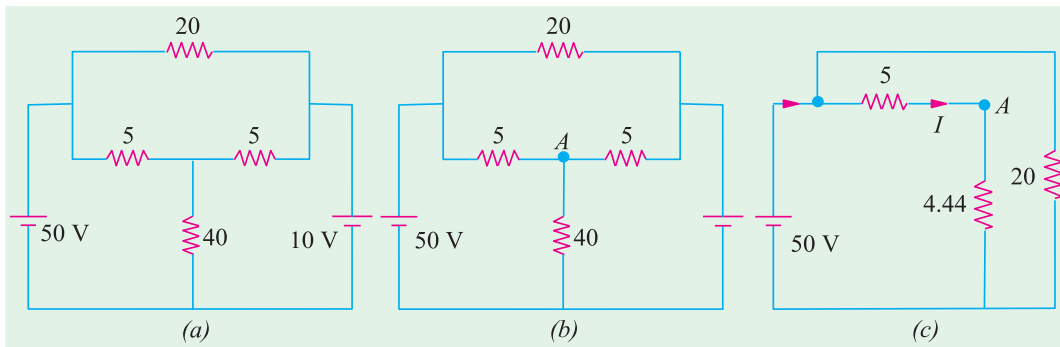

Fig. 2.101

At point A in Fig. 2.101 (b) there are two resistances of 5 Ω and 40 Ω connected in parallel, hence, current I divides between them as per the current-divider rule. If I_1 is the current flowing through the 40 Ω resistor, then

$$I_1 = I \frac{5}{5+40} = 5.296 \frac{5}{45} = 0.589 \text{ A.}$$

In Fig. 2.102 (a), 10 V battery acts alone because 50-V battery has been removed and replaced by a short-circuit.

As in the previous case, there are two parallel branches of resistances 20 Ω and 9.44 Ω across the 10-V battery. Current I through 9.44 Ω branch is $I = 10/9.44 = 1.059$ A. This current divides at point B between 5 Ω resistor and 40 Ω resistor. Current through 40 Ω resistor $I_2 = 1.059 \times 5/45 = 0.118$ A.

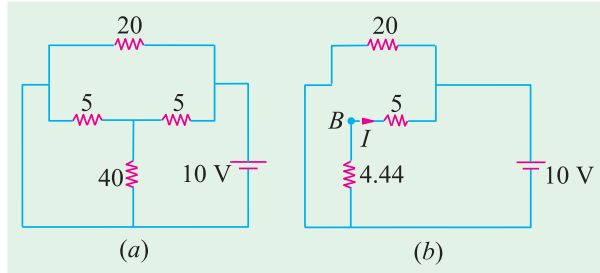

Fig. 2.102

According to the Superposition theorem, total current through 40 Ω resistance is $= I_1 + I_2 = 0.589 + 0.118 = 0.707$ A.

Example 2.51. Solve for the power delivered to the 10 Ω resistor in the circuit shown in Fig. 2.103 (a). All resistances are in ohms. (Elect. Science - I, Allahabad Univ. 1991)

Solution. The 4-A source and its parallel resistance of 15 Ω can be converted into a voltage source of $(15 \times 4) = 60$ V in series with a 15 Ω resistance as shown in Fig. 2.103 (b).

Now, we will use Superposition theorem to find current through the 10 Ω resistances.

When 60 –V Source is Removed

When 60 –V battery is removed the total resistance as seen by 2 V battery is $= 1 + 10 \parallel (15 + 5) = 7.67 \Omega$

The battery current $= 2/7.67$ A $= 0.26$ A. At point A , this current is divided into two parts. The current passing through the 10 Ω resistor from A to B is

$$I_1 = 0.26 \times (20/30) = 0.17 \text{ A}$$

When 2-V Battery is Removed

Then resistance seen by 60 V battery is $= 20 + 10 \parallel 1 = 20.9 \Omega$. Hence, battery current $= 60/20.9 = 2.87$ A. This current divides at point A . The current flowing through 10 Ω resistor from A to B is

$$I_2 = 2.87 \times 1/(1 + 10) = 0.26 \text{ A}$$

Total current through 10 Ω resistor due to two batteries acting together is $= I_1 + I_2 = 0.43$ A.

Power delivered to the 10 Ω resistor $= 0.43^2 \times 10 = 1.85$ W.

Example 2.52. Compute the power dissipated in the 9-W resistor of Fig. 2.104 by applying the Superposition principle. The voltage and current sources should be treated as ideal sources. All resistances are in ohms.

Solution. As explained earlier, an ideal constant-voltage source has zero internal resistances whereas a constant-current source has an infinite internal resistance.

(i) When Voltage Source Acts Alone

This case is shown in Fig. 2.104 (b) where constant-current source has been replaced by an open-circuit *i.e.* infinite resistance (Art. 2.16). Further circuit simplification leads to the fact that total resistances offered to voltage source is $= 4 + (12 \parallel 15) = 32/3 \Omega$ as shown in Fig. 2.104 (c).

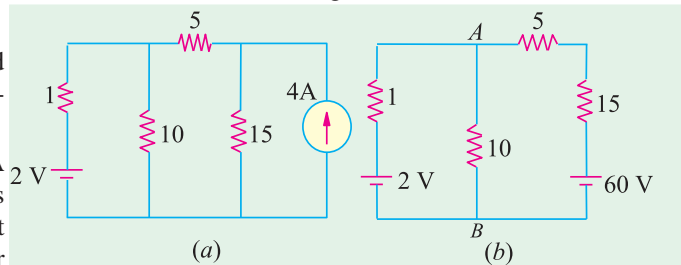

Fig. 2.103

Hence current = $32 \div 32/3 = 3$ A. At point A in Fig. 2.104 (d), this current divides into two parts. The part going along AB is the one that also passes through 9 Ω resistor.

$$I = 3 \times 12 / (15 + 12) = 4/3 \text{ A}$$

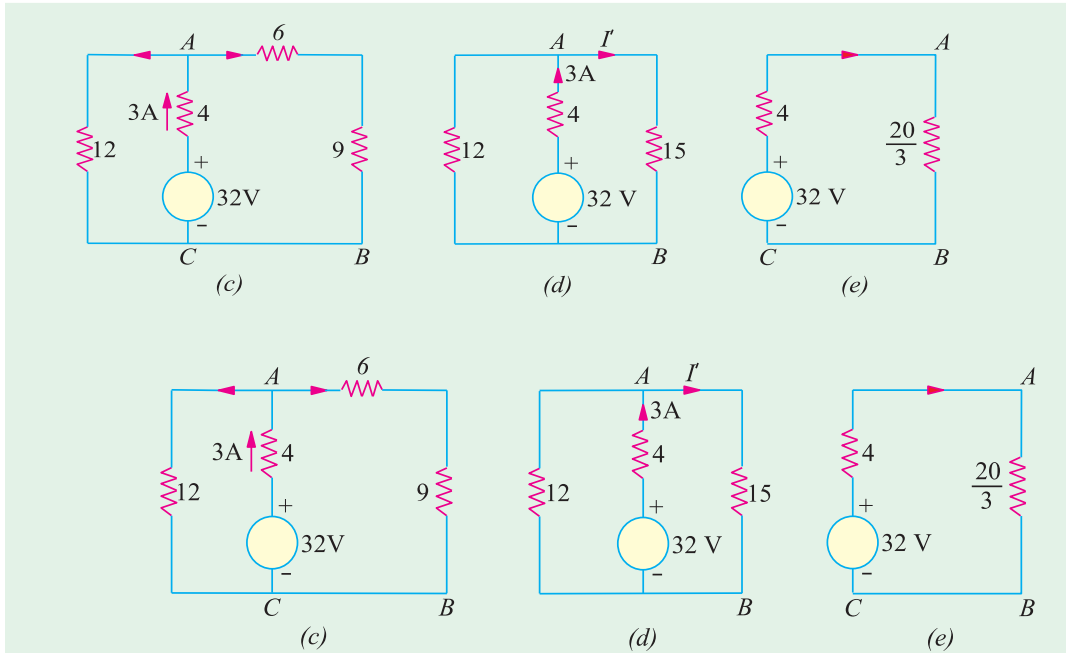

Fig. 2.104

(ii) When Current Source Acts Alone

As shown in Fig. 2.105 (a), the voltage source has been replaced by a short-circuit (Art 2.13). Further simplification gives the circuit of Fig. 2.105 (b).

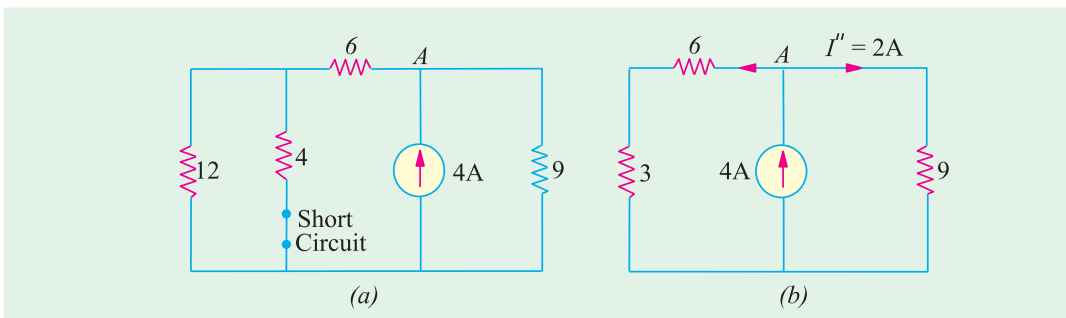

Fig. 2.105

The 4 - A current divides into two equal parts at point A in Fig. 2.105 (b). Hence $I = 4/2 = 2$ A. Since both I' and I'' flow in the same direction, total current through 9-Ω resistor is

$$I = I' + I'' = (4/3) + 2 = (10/3) \text{ A}$$

Power dissipated in 9 Ω resistor = $I^2 R = (10/3)^2 \times 9 = 100 \text{ W}$

Example 2.53(a). With the help of superposition theorem, obtain the value of current I and voltage V_0 in the circuit of Fig. 2.106 (a).

Solution. We will solve this question in three steps. First, we will find the value of I and V_0 when current source is removed and secondly, when voltage source is removed. Thirdly, we would combine the two values of I and V_0 in order to get their values when both sources are present.

First Step

As shown in Fig. 2.106 (b), current source has been replaced by an open-circuit. Let the values of current and voltage due to 10 V source be I_1 and V_{01} . As seen $I_1 = 0$ and $V_{01} = 10$ V.

Second Step

As shown in Fig. 2.106 (c), the voltage source has been replaced by a short circuit. Here $I_2 = -5$ A and $V_{02} = 5 \times 10 = 50$ V.

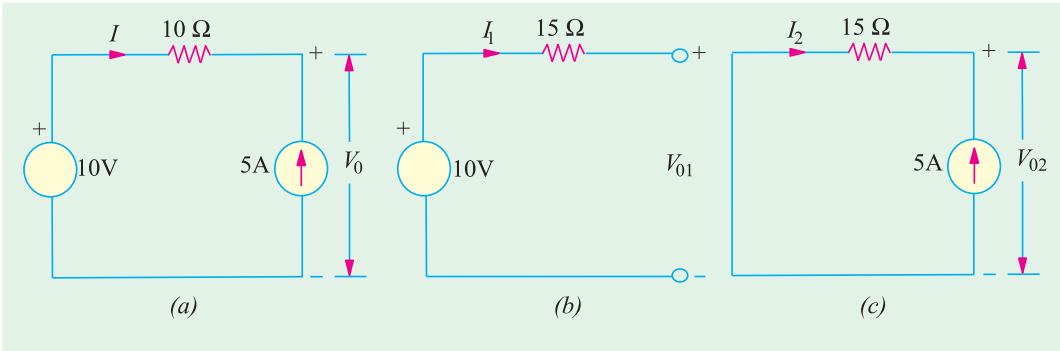

Fig. 2.106

Third Step

By applying superposition theorem, we have

$$I = I_1 + I_2 = 0 + (-5) = -5 \text{ A}$$

$$V_0 = V_{01} + V_{02} = 10 + 50 = 60 \text{ V}$$

Example 2.53(b). Using Superposition theorem, find the value of the output voltage V_0 in the circuit of Fig. 2.107.

Solution. As usual, we will break down the problem into three parts involving one source each.

(a) When 4 A and 6 V sources are killed*

As shown in Fig. 2.108 (a), 4 A source has been replaced by an open circuit and 6 V source by a short-circuit. Using the current-divider rule, we find current i_1 through the 2 Ω resistor = $6 \times 1/(1 + 2 + 3) = 1$ A $\therefore V_{01} = 1 \times 2 = 2$ V.

(b) When 6 A and 6 V sources are killed

As shown in Fig. 2.108 (b), 6 A source has been replaced by an open-circuit and 6 V source by a short-circuit. The current i_2 can again be found with the help of current-divider rule because there are two parallel paths across the current source. One has a resistance of 3 Ω and the other of $(2 + 1) = 3$ Ω. It means that current divides equally at point A.

$$\text{Hence, } i_2 = 4/2 = 2 \text{ A} \quad \therefore V_{02} = 2 \times 2 = 4 \text{ V}$$

(c) When 6 A and 4 A sources are killed

As shown in Fig. 2.108 (c), drop over 2 Ω resistor = $6 \times 2/6 = 2$ V. The potential of point B with respect to point A is $6 - 2 = +4$ V. Hence, $V_{03} = -4$ V.

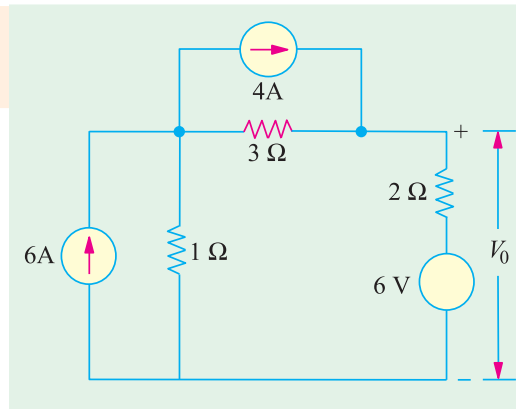

Fig. 2.107

* The process of setting of voltage source of zero is called *killing* the sources.

According to Superposition theorem, we have

$$V_0 = V_{01} + V_{02} + V_{03} = 2 + 4 - 4 = 2 \text{ V}$$

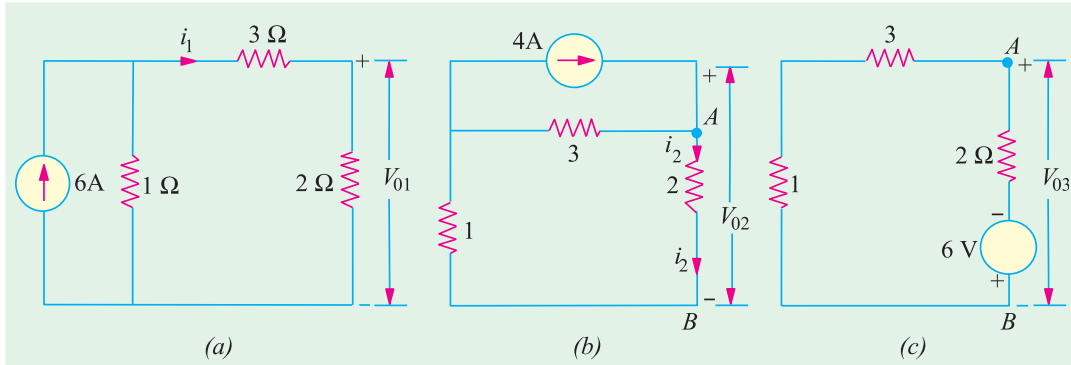

Fig. 2.108

Example 2.54. Use Superposition theorem, to find the voltage V in Fig. 2.109 (a).

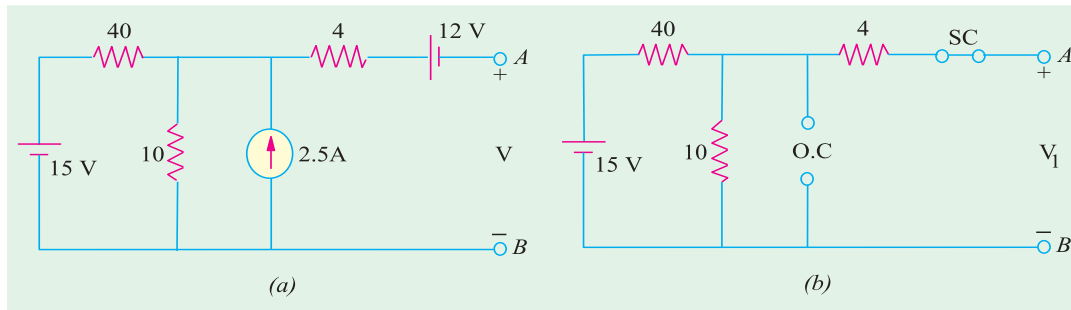

Fig. 2.109

Solution. The given circuit has been redrawn in Fig. 2.109 (b) with 15 - V battery acting alone while the other two sources have been killed. The 12 - V battery has been replaced by a short-circuit and the current source has been replaced by an open-circuit (O.C) (Art. 2.19). Since the output terminals are open, no current flows through the 4 Ω resistor and hence, there is no voltage drop across it. Obviously V_1 equals the voltage drop over 10 Ω resistor which can be found by using the voltage-divider rule.

$$V_1 = 15 \times 10 / (40 + 10) = 3 \text{ V}$$

Fig. 2.110 (a) shows the circuit when current source acts alone, while two batteries have been killed. Again, there is no current through 4 Ω resistor. The two resistors of values 10 Ω and 40 Ω are

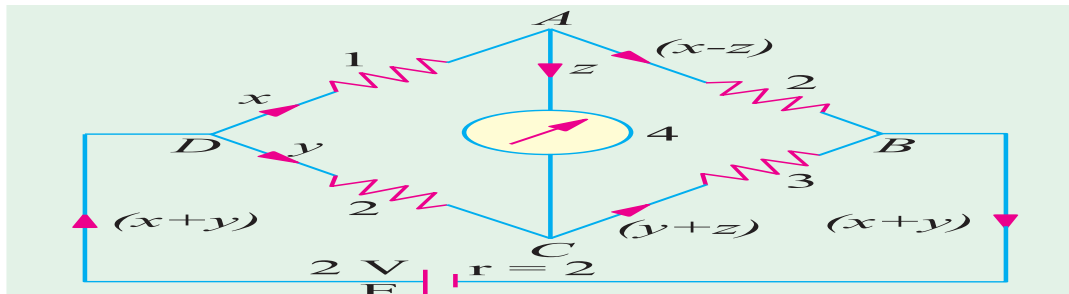

Fig. 2.110

in parallel across the current source. Their combined resistances is $10 \parallel 40 = 8 \Omega$

$$\therefore V_2 = 8 \times 2.5 = 20 \text{ V with point A positive.}$$

Fig. 2.110 (b) shows the case when 12 V battery acts alone. Here, $V_3 = -12 \text{ V}^*$. Minus sign has been taken because negative terminal of the battery is connected to point A and the positive terminal to point B. As per the Superposition theorem,

$$V = V_1 + V_2 + V_3 = 3 + 20 - 12 = 11 \text{ V}$$

Example 2.55. Apply Superposition theorem to the circuit of Fig. 2.107 (a) for finding the voltage drop V across the 5Ω resistor.

Solution. Fig. 2.111 (b) shows the redrawn circuit with the voltage source acting alone while the two current sources have been ‘killed’ i.e. have been replaced by open circuits. Using voltage-divider principle, we get

$V_1 = 60 \times 5 / (5 + 2 + 3) = 30 \text{ V}$. It would be taken as positive, because current through the 5Ω resistances flows from A to B, thereby making the upper end of the resistor positive and the lower end negative.

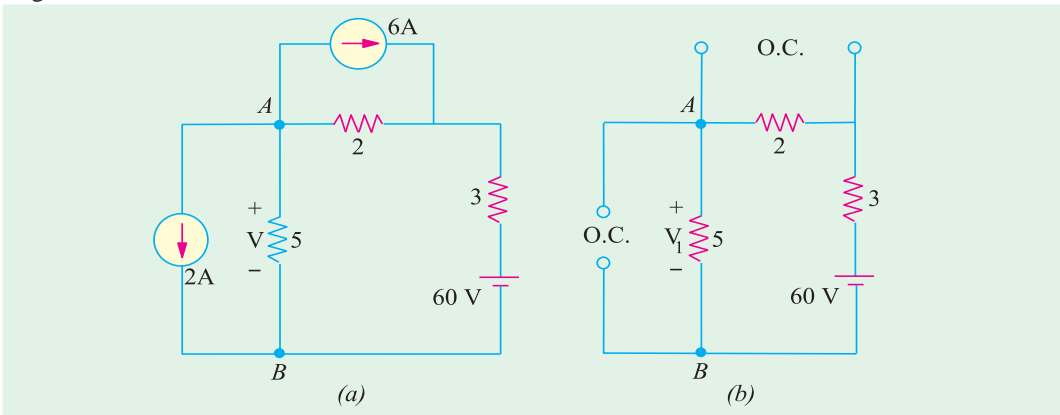

Fig. 2.111

Fig. 2.112 (a) shows the same circuit with the 6 A source acting alone while the two other sources have been ‘killed’. It will be seen that 6 A source has to parallel circuits across it, one having a resistance of 2Ω and the other $(3 + 5) = 8 \Omega$. Using the current-divider rule, the current through the 5Ω resistor = $6 \times 2 / (2 + 3 + 5) = 1.2 \text{ A}$.

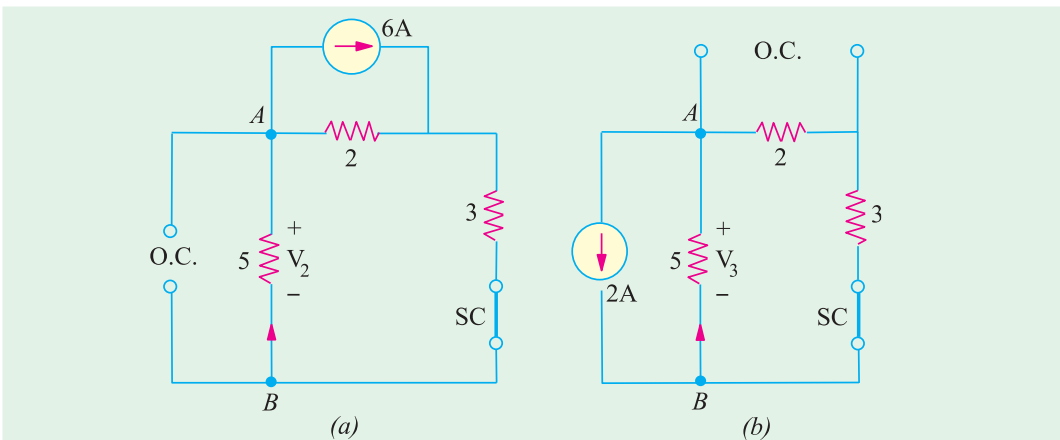

Fig. 2.112

* Because Fig. 2.110 (b) resembles a voltage source with an internal resistance = $4 + 10 \parallel 40 = 12 \Omega$ and which is an open-circuit.

$\therefore V_2 = 1.2 \times 5 = 6 \text{ V}$. It would be taken *negative* because current is flowing from *B* to *A*. *i.e.* point *B* is at a higher potential as compared to point *A*. Hence, $V_2 = -6 \text{ V}$.

Fig. 2.112 (b) shows the case when 2-A source acts alone, while the other two sources are dead. As seen, this current divides equally at point *B*, because the two parallel paths have equal resistances of 5Ω each. Hence, $V_3 = 5 \times 1 = 5 \text{ V}$. It would also be taken as negative because current flows from *B* to *A*. Hence, $V_3 = -5 \text{ V}$.

Using Superposition principle, we get

$$V = V_1 + V_2 + V_3 = 30 - 6 - 5 = 19 \text{ V}$$

Example 2.56. (b) Determine using superposition theorem, the voltage across the 4 ohm resistor shown in Fig. 2.113 (a) [Nagpur University, Summer 2000]

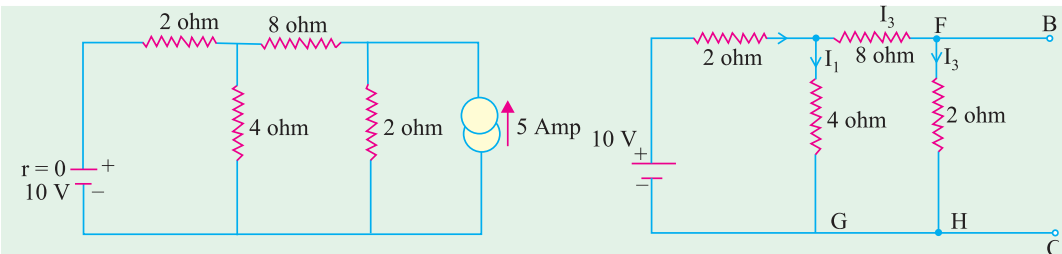

Fig. 2.113 (a)

Fig. 2.113 (b)

Solution. Superposition theorem needs one source acting at a time.

Step I : De-acting current source.

The circuit is redrawn after this change in Fig. 2.113 (b)

$$I_1 = \frac{10}{2 + \frac{4 \times (8 + 2)}{4 + (8 + 2)}} = \frac{10}{2 + \frac{40}{14}} = 2.059 \text{ amp}$$

$$I_2 = \frac{2.059 \times 10}{14} = 1.471 \text{ amp, in downward direction}$$

Step II : De-activate the voltage source.

The circuit is redrawn after the change, in Fig. 2.113 (c)

With the currents marked as shown.

$I_d = 2I_c$ relating the voltage drops in Loop ADC.

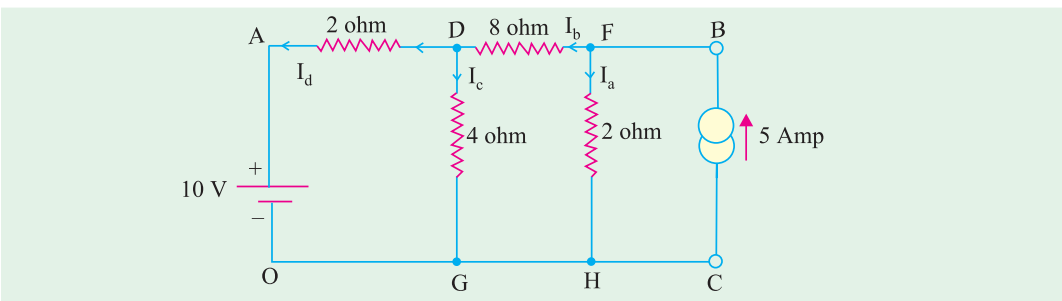

Fig. 2.113 (c)

Thus $I_b = 3 I_c$.

Resistance of parallel combination of

$$2 \text{ and } 4 \text{ ohms} = \frac{2 \times 4}{2 + 4} = 1.333 \Omega$$

$$\text{Resistance for flow of } I_b = 8 + 1.333 = 9.333 \Omega$$

The 5-amp current from the sources gets divided into $I_b (= 3 I_c)$ and I_a , at the node F.

$$I_b = 3 I_c = \frac{2.0}{2.0 + 9.333} \times 5 = 0.8824$$

$\therefore I_c = 0.294$ amp, in downward direction.

Step III. Apply superposition theorem, for finding the total current into the 4-ohm resistor
 = Current due to Current source + Current due to Voltage source
 = $0.294 + 1.471 = 1.765$ amp in downward direction.

Check. In the branch AD ,

The voltage source drives a current from A to D of 2.059 amp, and the current source drives a current of $I_d (= 2I_c)$ which is 0.588 amp, from D to A .

The net current in branch AD

$$= 2.059 - 0.588 = 1.471 \text{ amp} \quad \dots \text{eqn. (a)}$$

With respect to O , A is at a potential of + 10 volts.

Potential of D with respect to O

$$\begin{aligned} &= (\text{net current in resistor}) \times 4 \\ &= 1.765 \times 4 = + 7.06 \text{ volts} \end{aligned}$$

Between A and D , the potential difference is $(10 - 7.06)$ volts

Hence, the current through this branch

$$= \frac{10 - 7.06}{2} = 1.47 \text{ amp from } A \text{ to } D \quad \dots \text{eqn (b)}$$

This is the same as eqn. (a) and hence checks the result, obtained previously.

Example 2.57. Find the current flowing in the branch XY of the circuit shown in Fig. 2.114 (a) by superposition theorem. [Nagpur University, April 1996]

Solution. As shown in Fig. 2.114 (b), one source is de-activated. Through series-parallel combinations of resistances, the currents due to this source are calculated. They are marked as Fig. 2.114 (b).

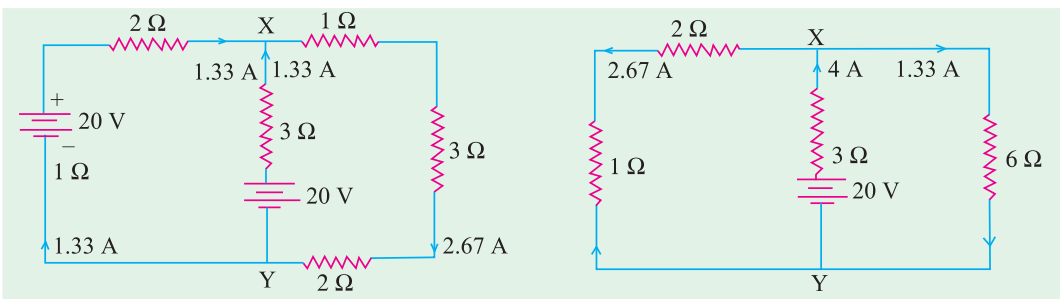

Fig. 2.114 (a)

Fig. 2.114 (b)

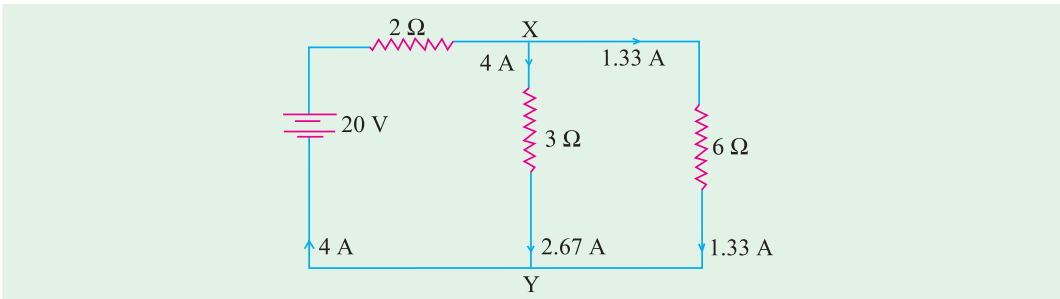

Fig. 2.114 (c)

In the next step, second source is de-activated as in Fig. 2.114 (c). Through simple series parallel resistances combinations, the currents due to this source are marked on the same figure.

According to the superposition theorem, the currents due to both the sources are obtained after adding the individual contributions due to the two sources, with the final results marked on Fig. 2.114 (a). Thus, the current through the branch XY is 1.33 A from Y to X.

Example 2.58. Find the currents in all the resistors by Superposition theorem in the circuit shown in Fig. 2.115 (a). Calculate the power consumed. [Nagpur University, Nov. 1996]

Solution. According to Superposition theorem, one source should be retained at a time, deactivating remaining sources. Contributions due to individual sources are finally algebraically added to get the answers required. Fig. 2.115 (b) shows only one source retained and the resultant currents in all branches/elements. In Fig. 2.115 (c), other source is shown to be in action, with concerned currents in all the elements marked.

To get the total current in any element, two component-currents in Fig. 2.115 (b) and Fig. 2.115 (c) for the element are to be algebraically added. The total currents are marked on Fig. 2.115 (a).

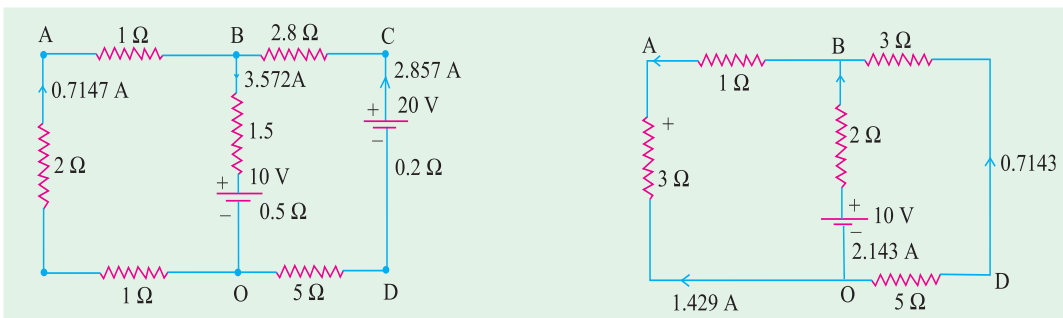

Fig. 2.115 (a)

Fig. 2.115 (b)

All resistors are in ohms

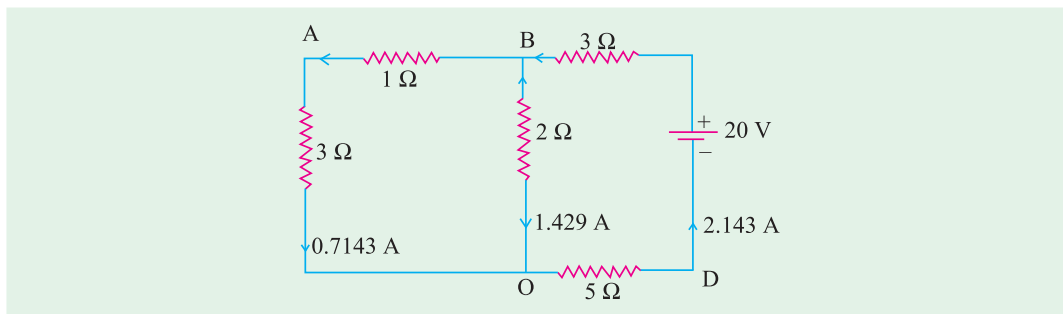

Fig. 2.115 (c)

Power loss calculations. (i) from power consumed by resistors :

$$\text{Power} = (0.7147^2 \times 4) + (3.572^2 \times 2) + (2.875^2 \times 8) = 92.86 \text{ watts}$$

(ii) From Source-power.

$$\text{Power} = 10 \times 3.572 + 20 \times 2.857 = 92.86 \text{ watts}$$

Tutorial Problems No. 2.4.

1. Apply the principle of Superposition to the network shown in Fig. 2.116 to find out the current in the 10 Ω resistance. [0.464 A] (F.Y. Engg. Pune Univ.)
2. Find the current through the 3 Ω resistance connected between C and D Fig. 2.117.

[1 A from C to D] (F.Y. Engg. Pune Univ.)

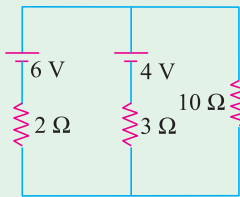

Fig. 2.116

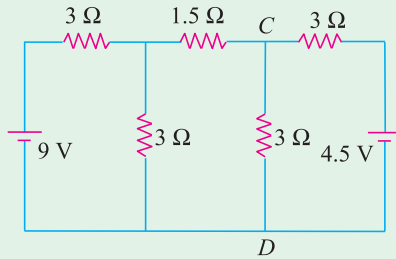

Fig. 2.117

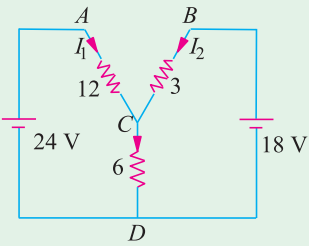

Fig. 2.118

3. Using the Superposition theorem, calculate the magnitude and direction of the current through each resistor in the circuit of Fig. 2.118. [$I_1 = 6/7$ A; $I_2 = 10/7$ A; $I_3 = 16/7$ A]

4. For the circuit shown in Fig. 2.119 find the current in $R = 8\ \Omega$ resistance in the branch AB using superposition theorem. [0.875 A] (F.Y. Engg. Pune Univ.)

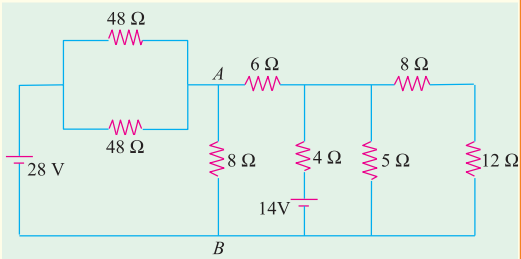

Fig. 2.119

5. Apply superposition principle to compute current in the 2-Ω resistor of Fig. 2.120. All resistors are in ohms. [$I_{ab} = 5$ A]

6. Use Superposition theorem to calculate the voltage drop across the 3 Ω resistor of Fig. 2.121. All resistance values are in ohms. [18 V]

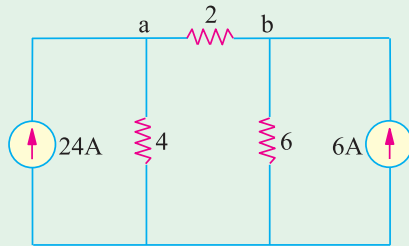

Fig. 2.120

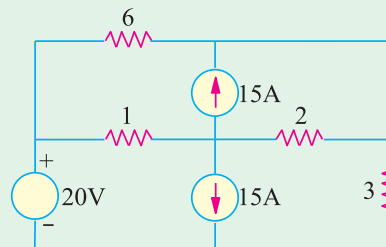

Fig. 2.121

7. With the help of Superposition theorem, compute the current I_{ab} in the circuit of Fig. 2.122. All resistances are in ohms. [$I_{ab} = -3$ A]

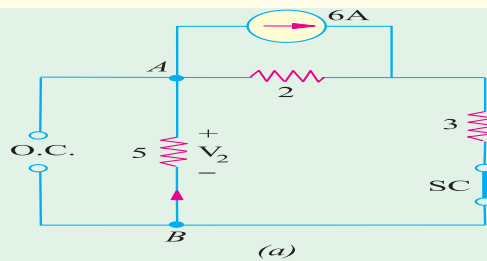

Fig. 2.122

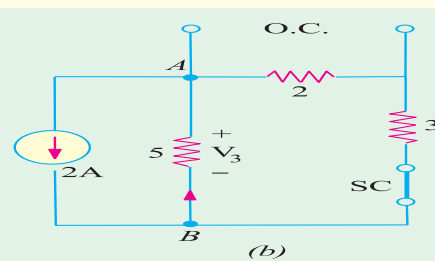

Fig. 2.123

8. Use Superposition theorem to find current I_{ab} in the circuit of Fig. 2.123. All resistances are in ohms. [100 A]

9. Find the current in the 15 Ω resistor of Fig. 2.124 by using Superposition principle. Numbers represent resistances in ohms. [2.8 A]

10. Use Superposition principle to find current in the 10-Ω resistor of Fig. 2.125. All resistances are in ohms. [1 A]
11. State and explain Superposition theorem. For the circuit of Fig. 2.126.
- (a) determine currents I_1 , I_2 and I_3 when switch S is in position b .
- (b) using the results of part (a) and the principle of superposition, determine the same currents with switch S in position a .

[(a) 15 A, 10 A, 25 A (b) 11 A, 16 A, 27 A] (Elect. Technology Vikram Univ.)

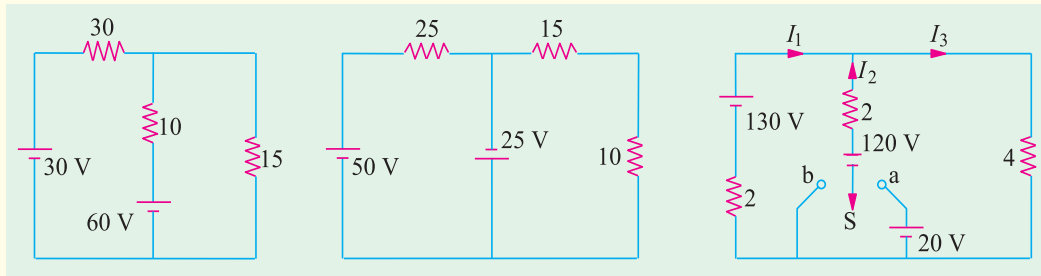
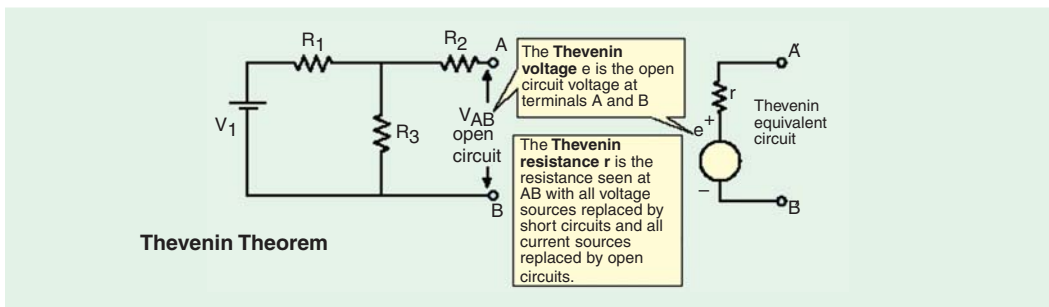

Fig. 2.124

Fig. 2.125

Fig. 2.126

2.18. Thevenin Theorem



It provides a mathematical technique for replacing a given network, as viewed from two output terminals, by **a single voltage source with a series resistance**. It makes the solution of complicated networks (particularly, electronic networks) quite quick and easy. The application of this extremely useful theorem will be explained with the help of the following simple example.

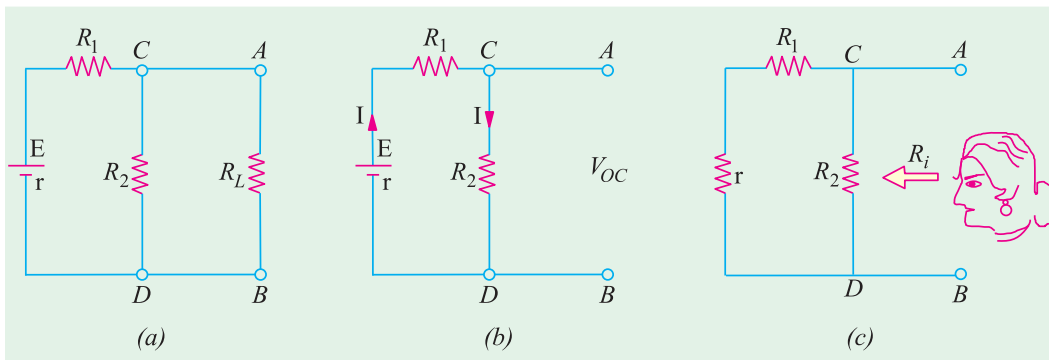

Fig. 2.127

Suppose, it is required to find current flowing through load resistance R_L , as shown in Fig. 2.127 (a). We will proceed as under :

1. Remove R_L from the circuit terminals A and B and redraw the circuit as shown in Fig. 2.127 (b). Obviously, the terminals have become open-circuited.
2. Calculate the open-circuit voltage V_{oc} which appears across terminals A and B when they are open *i.e.* when R_L is removed.

As seen, $V_{oc} = \text{drop across } R_2 = IR_2$ where I is the circuit current when A and B are open.

$$I = \frac{E}{R_1 + R_2 + r} \quad \therefore V_{oc} = IR_2 = \frac{ER_2}{R_1 + R_2 + r} \quad [r \text{ is the internal resistance of battery}]$$

It is also called 'Thevenin voltage' V_{th} .

3. Now, imagine the battery to be removed from the circuit, leaving its internal resistance r behind and redraw the circuit, as shown in Fig. 2.127 (c). When viewed *inwards* from terminals A and B , the circuit consists of two parallel paths : one containing R_2 and the other containing $(R_1 + r)$. The equivalent resistance of the network, as viewed from these terminals is given as

$$R = R_2 \parallel (R_1 + r) = \frac{R_2(R_1 + r)}{R_2 + (R_1 + r)}$$

This resistance is also called, * Thevenin resistance R_{sh} (though, it is also sometimes written as R_i or R_0).

Consequently, as viewed from terminals A and B , the whole network (excluding R_L) can be reduced to a single source (called Thevenin's source) whose e.m.f. equals V_{oc} (or V_{sh}) and whose internal resistance equals R_{sh} (or R_i) as shown in Fig. 2.128.

4. R_L is now connected back across terminals A and B from where it was temporarily removed earlier. Current flowing through R_L is given by

$$I = \frac{V_{th}}{R_{th} + R_L}$$

It is clear from above that any network of resistors and voltage sources (and current sources as well) when viewed from any points A and B in the network, can be replaced by a single voltage source and a single resistance** in series with the voltage source.

After this replacement of the network by a single voltage source with a series resistance has been accomplished, it is easy to find current in any load resistance joined across terminals A and B . This theorem is valid even for those linear networks which have a nonlinear load.

Hence, Thevenin's theorem, as applied to d.c. circuits, may be stated as under :

The current flowing through a load resistance R_L connected across any two terminals A and B of a linear, active bilateral network is given by $V_{oc} \parallel (R_i + R_L)$ where V_{oc} is the open-circuit voltage (*i.e.* voltage across the two terminals when R_L is removed) and R_i is the internal resistance of the network as viewed back into the open-circuited network from terminals A and B with all voltage sources replaced by their internal resistance (if any) and current sources by infinite resistance.

* After the French engineer M.L. Thevenin (1857-1926) who while working in Telegraphic Department published a statement of the theorem in 1893.

** Or impedance in the case of a.c. circuits.

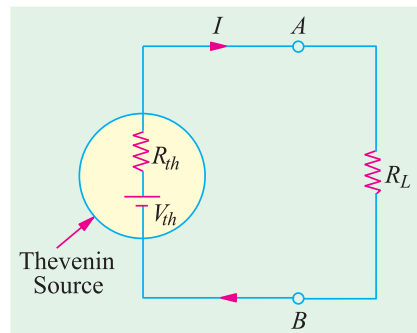

Fig. 2.128

2.19. How to Thevenize a Given Circuit ?

1. Temporarily remove the resistance (called load resistance R_L) whose current is required.
2. Find the open-circuit voltage V_{oc} which appears across the two terminals from where resistance has been removed. It is also called Thevenin voltage V_{th} .
3. Compute the resistance of the whose network as looked into from these two terminals after all voltage sources have been removed leaving behind their internal resistances (if any) and current sources have been replaced by open-circuit *i.e.* infinite resistance. It is also called Thevenin resistance R_{th} or T_i .
4. Replace the entire network by a single Thevenin source, whose voltage is V_{th} or V_{oc} and whose internal resistance is R_{th} or R_i .
5. Connect R_L back to its terminals from where it was previously removed.
6. Finally, calculate the current flowing through R_L by using the equation,

$$I = V_{th}/(R_{th} + R_L) \quad \text{or} \quad I = V_{oc}/(R_i + R_L)$$

Example 2.59. Convert the circuit shown in Fig. 2.129 (a), to a single voltage source in series with a single resistor.
(AMIE Sec. B, Network Analysis Summer 1992)

Solution. Obviously, we have to find equivalent Thevenin circuit. For this purpose, we have to calculate (i) V_{th} or V_{AB} and (ii) R_{th} or R_{AB} .

With terminals A and B open, the two voltage sources are connected in subtractive series because they oppose each other. Net voltage around the circuit is $(15 - 10) = 5$ V and total resistance is $(8 + 4) = 12 \Omega$. Hence circuit current is $= 5/12$ A. Drop across 4Ω resistor $= 4 \times 5/12 = 5/3$ V with the polarity as shown in Fig. 2.129 (a).

$$\therefore V_{AB} = V_{th} = +10 + 5/3 = 35/3 \text{ V.}$$

Incidentally, we could also find V_{AB} while going along the parallel route $BFEA$.

Drop across 8Ω resistor $= 8 \times 5/12 = 10/3$ V. V_{AB} equal the algebraic sum of voltages met on the way from B to A. Hence, $V_{AB} = (-10/3) + 15 = 35/3$ V.

As shown in Fig. 2.129 (b), the single voltage source has a voltage of $35/3$ V.

For finding R_{th} , we will replace the two voltage sources by short-circuits. In that case, $R_{th} = R_{AB} = 4 \parallel 8 = 8/3 \Omega$

Example 2.60. State Thevenin's theorem and give a proof. Apply this theorem to calculate the current through the 4Ω resistor of the circuit of Fig. 2.130 (a).
(A.M.I.E. Sec. B Network Analysis W.)

Solution. As shown in Fig. 2.130 (b), 4Ω resistance has been removed thereby open-circuiting the terminals A and B. We will now find V_{AB} and R_{AB} which will give us V_{th} and R_{th} respectively. The potential drop across 5Ω resistor can be found with the help of voltage-divider rule. Its value is $= 15 \times 5/(5 + 10) = 5$ V.

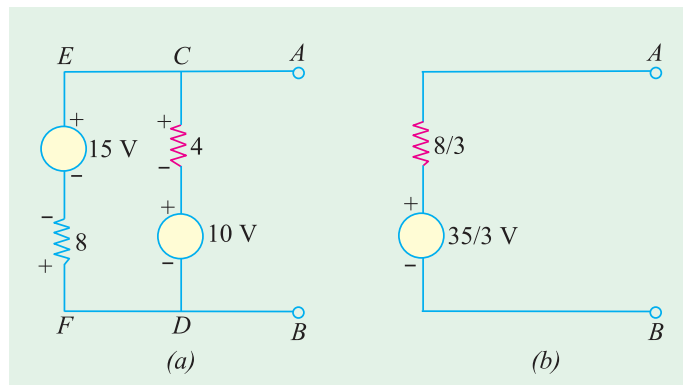

Fig. 2.129

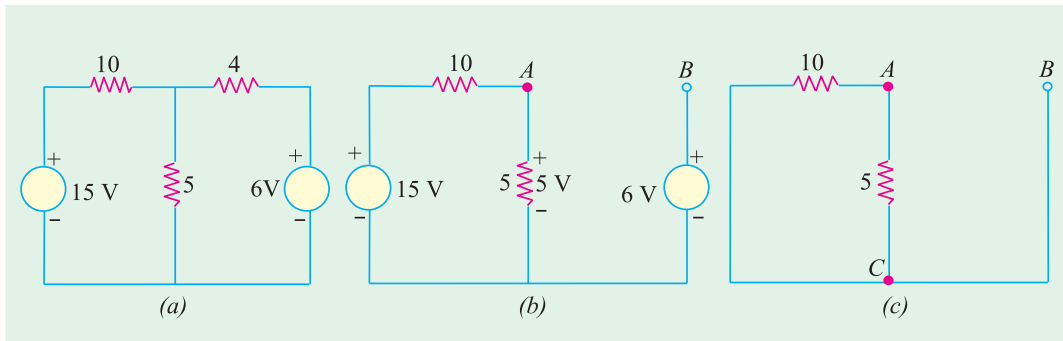

Fig. 2.130

For finding V_{AB} , we will go from point B to point A in the clockwise direction and find the algebraic sum of the voltages met on the way.

$$\therefore V_{AB} = -6 + 5 = -1 \text{ V.}$$

It means that point A is negative with respect to point E , or point B is at a higher potential than point A by one volt.

In Fig. 2.130 (c), the two voltage source have been short-circuited. The resistance of the network as viewed from points A and B is the same as viewed from points A and C .

$$\therefore R_{AB} = R_{AC} = 5 \parallel 10 = 10/3 \Omega$$

Thevenin's equivalent source is shown in Fig. 2.131 in which 4Ω resistor has been joined back across terminals A and B . Polarity of the voltage source is worth nothing.

$$\therefore I = \frac{1}{(10/3) + 4} = \frac{3}{22} = 0.136 \text{ A} \quad \text{From } E \text{ to } A$$

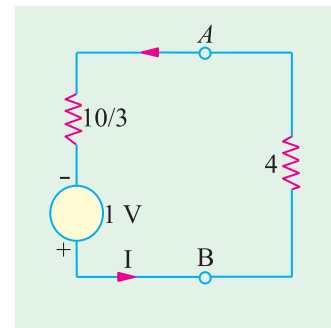

Fig. 2.131

Example 2.61. With reference to the network of Fig. 2.132 (a), by applying Thevenin's theorem find the following :

- (i) the equivalent e.m.f. of the network when viewed from terminals A and B .
- (ii) the equivalent resistance of the network when looked into from terminals A and B .
- (iii) current in the load resistance R_L of 15Ω . (Basic Circuit Analysis, Nagpur Univ. 1993)

Solution. (i) Current in the network before load resistance is connected [Fig. 2.132 (a)]
 $= 24/(12 + 3 + 1) = 1.5 \text{ A}$

$$\therefore \text{voltage across terminals } AB = V_{oc} = V_{th} = 12 \times 1.5 = 18 \text{ V}$$

Hence, so far as terminals A and B are concerned, the network has an e.m.f. of 18 volt (and not 24 V).

(ii) There are two parallel paths between points A and B . Imagine that battery of 24 V is removed but not its internal resistance. Then, resistance of the circuit as looked into from point A and B is [Fig. 2.132 (c)]

$$R_i = R_{th} = 12 \times 4/(12 + 4) = 3 \Omega$$

(iii) When load resistance of 15Ω is connected across the terminals, the network is reduced to the structure shown in Fig. 2.132 (d).

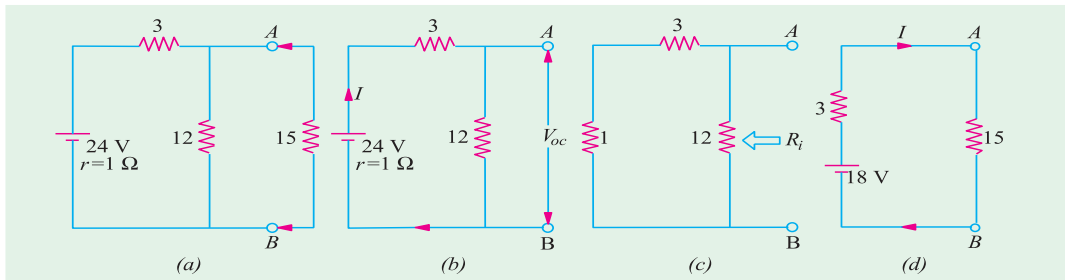

Fig. 2.132

$$I = V_{th}/(R_{th} + R_L) = 18/(15 + 3) = 1 \text{ A}$$

Example 2.62. Using Thevenin theorem, calculate the current flowing through the 4 Ω resistor of Fig. 2.133 (a).

Solution. (i) Finding V_{th}

If we remove the 4-Ω resistor, the circuit becomes as shown in Fig. 2.133 (b). Since full 10 A current passes through 2 Ω resistor, drop across it is $10 \times 2 = 20 \text{ V}$. Hence, $V_B = 20 \text{ V}$ with respect to the common ground. The two resistors of 3 Ω and 6 Ω are connected in series across the 12 V battery. Hence, drop across 6 Ω resistor = $12 \times 6/(3 + 6) = 8 \text{ V}$.

$$\therefore V_A = 8 \text{ V with respect to the common ground}^*$$

$$\therefore V_{th} = V_{BA} = V_B - V_A = 20 - 8 = 12 \text{ V—with } B \text{ at a higher potential}$$

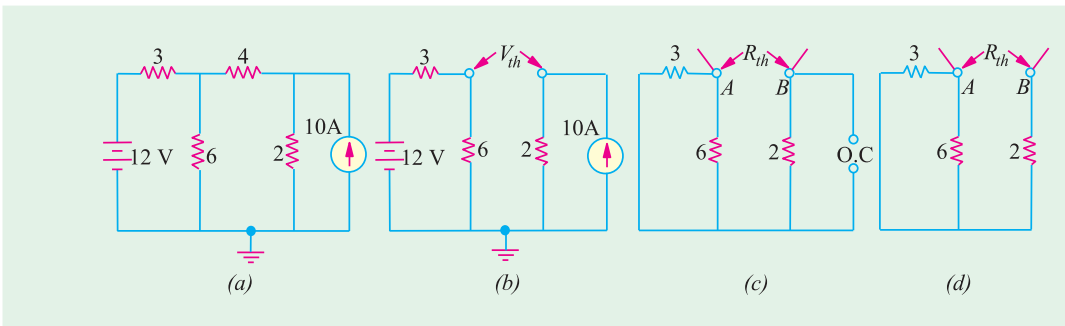

Fig. 2.133

(ii) Finding R_{th}

Now, we will find R_{th} i.e. equivalent resistance of the network as looked back into the open-circuited terminals A and B. For this purpose, we will replace both the voltage and current sources. Since voltage source has no internal resistance, it would be replaced by a short circuit i.e. zero resistance. However, current source would be removed and replaced by an ‘open’ i.e. infinite resistance (Art. 1.18). In that case, the circuit becomes as shown in Fig. 2.133 (c). As seen from Fig. 2.133 (d), $R_{th} = 6 \parallel 3 + 2 = 4 \Omega$. Hence, Thevenin’s equivalent circuit consists of a voltage source of 12 V and a series resistance of 4 Ω as shown in Fig. 2.134 (a). When 4 Ω resistor is connected across terminals A and B, as shown in Fig. 2.134 (b).

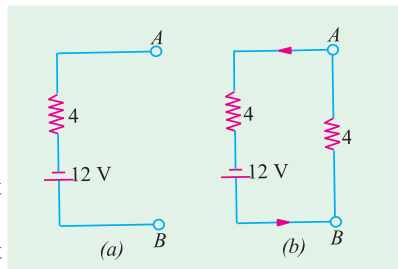

Fig. 2.134

$$I = 12/(4 + 4) = 1.5 \text{ A—from } B \text{ to } A$$

* Also, $V_A = 12 - \text{drop across } 3\text{-}\Omega \text{ resistor} = 12 - 12 \times 3/(6 + 3) = 12 - 4 = 8 \text{ V}$

Example 2.63. For the circuit shown in Fig. 2.135 (a), calculate the current in the 10 ohm resistance. Use Thevenin's theorem only.

(Elect. Science-I Allahabad Univ. 1992)

Solution. When the 10 Ω resistance is removed, the circuit becomes as shown in Fig. 2.135 (b).

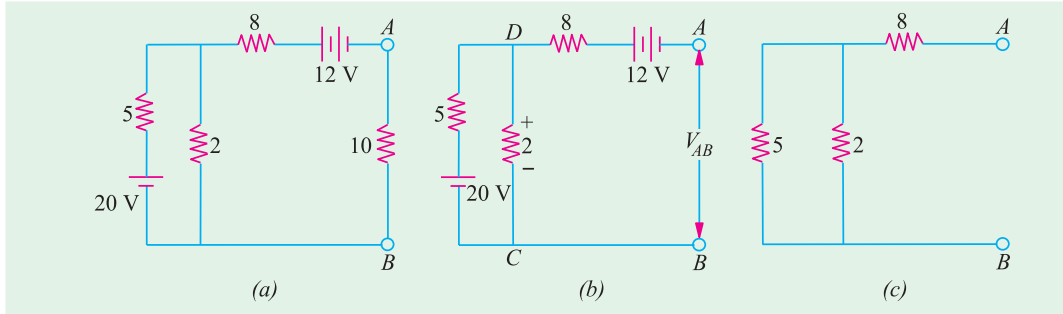

Fig. 2.135

Now, we will find the open-circuit voltage $V_{AB} = V_{th}$. For this purpose, we will go from point B to point A and find the algebraic sum of the voltages met on the way. It should be noted that with terminals A and B open, there is no voltage drop on the 8 Ω resistance. However the two resistances of 5 Ω and 2 Ω are connected in series across the 20-V battery. As per voltage-divider rule, drop on 2 Ω resistance = $20 \times 2/(2 + 5) = 5.71$ V with the polarity as shown in figure. As per the sign convention of Art.

$$V_{AB} = V_{th} = + 5.71 - 12 = -6.29 \text{ V}$$

The negative sign shows that point A is negative with respect to point B or which is the same thing, point B is positive with respect to point A .

For finding $R_{AB} = R_{th}$, we replace the batteries by short-circuits as shown in Fig. 2.128 (c).

$$\therefore R_{AB} = R_{th} = 8 + 2 \parallel 5 = 9.43 \text{ } \Omega$$

Hence, the equivalent Thevenin's source with respect to terminals A and B is as shown in Fig. 2.136. When 10 Ω resistance is reconnected across A and B , current through it is $I = 6.24/(9.43 + 10) = 0.32$ A.

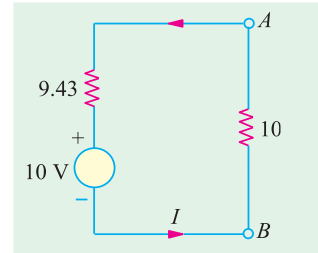

Fig. 2.136 (a)

Example 2.64. Using Thevenin's theorem, calculate the p.d. across terminals A and B in Fig. 2.137 (a).

Solution. (i) Finding V_{oc}

First step is to remove 7 Ω resistor thereby open-circuiting terminals A and B as shown in Fig. 2.137 (b). Obviously, there is no current through the 1 Ω resistor and hence no drop across it. Therefore $V_{AB} = V_{oc} = V_{CD}$. As seen, current I flows due to the combined action of the two batteries. Net voltage in the $CDFE$ circuit = $18 - 6 = 12$ V. Total resistance = $6 + 3 = 9$ Ω Hence, $I = 12/9 = 4/3$ A

$$V_{CD} = 6 \text{ V} + \text{drop across } 3 \text{ } \Omega \text{ resistor} = 6 + (4/3) \times 3 = 10 \text{ V}^*$$

$$\therefore V_{oc} = V_{th} = 10 \text{ V.}$$

(ii) Finding R_i or R_{th}

As shown in Fig. 2.137 (c), the two batteries have been replaced by short-circuits (SC) since their internal resistances are zero. As seen, $R_i = R_{th} = 1 + 3 \parallel 6 = 3$ Ω. The Thevenin's equivalent circuit is as shown in Fig. 2.137 (d) where the 7 Ω resistance has been reconnected across terminals A and B .

* Also, $V_{cd} = 18 - \text{drop across } 6 \text{ } \Omega \text{ resistor} = 18 - (4/3) \times 6 = 10 \text{ V}$

The p.d. across this resistor can be found with the help of Voltage Divider Rule (Art. 1.15).

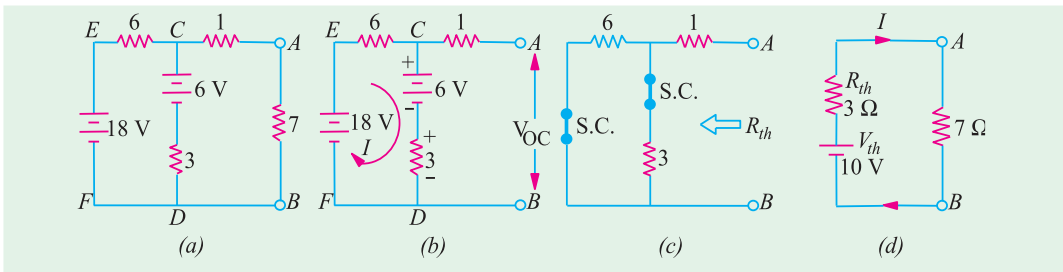

Fig. 2.137

Example 2.65. Use Thevenin's theorem to find the current in a resistance load connected between the terminals A and B of the network shown in Fig. 2.138 (a) if the load is (a) 2 Ω (b) 1 Ω

(Elect. Technology, Gwalior Univ.)

Solution. For finding open-circuit voltage V_{oc} or V_{th} across terminals A and B, we must first find current I_2 flowing through branch CD. Using Maxwell's loop current method (Art. 2.11), we have from Fig. 2.131 (a).

$$-2 I_1 - 4 (I_1 - I_2) + 8 = 0 \quad \text{or} \quad 3 I_1 - 2 I_2 = 4$$

$$\text{Also} \quad -2 I_2 - 2 I_2 - 4 - 4 (I_2 - I_1) = 0 \quad \text{or} \quad I_1 - 2 I_2 = 1$$

From these two equations, we get $I_2 = 0.25$ A

As we go from point D to C, voltage rise = $4 + 2 \times 0.25 = 4.5$ V

Hence, $V_{CD} = 4.5$ or $V_{AB} = V_{th} = 4.5$ V. Also, it may be noted that point A is positive with respect to point B.

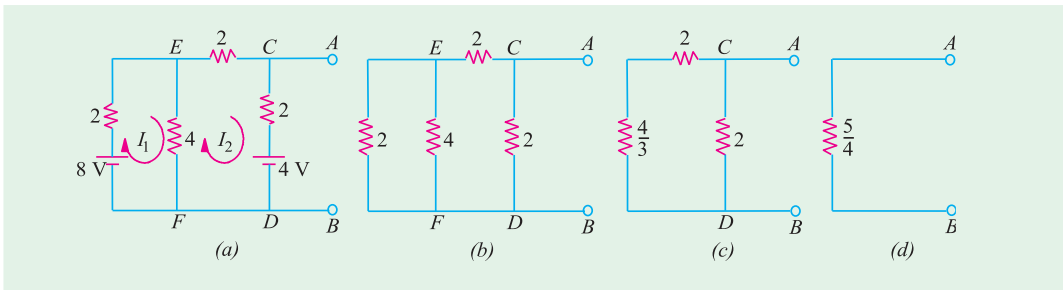

Fig. 2.138

In Fig. 2.138 (b), both batteries have been removed. By applying laws of series and parallel combination of resistances, we get $R_i = R_{th} = 5/4 \Omega = 1.25 \Omega$

(i) When $R_L = 2 \Omega$; $I = 4.5 / (2 + 1.25) = 1.38$ A

(ii) When $R_L = 1 \Omega$; $I = 4.5 / (1 + 1.25) = 2.0$ A

Note. We could also find V_{oc} and R_i by first Thevenining part of the circuit across terminals E and F and then across A and B (Ex. 2.62).

Example 2.66. The four arms of a Wheatstone bridge have the following resistances :

$AB = 100$, $BC = 10$, $CD = 4$, $DA = 50 \Omega$. A galvanometer of 20Ω resistance is connected across BD. Use Thevenin's theorem to compute the current through the galvanometer when a p.d. of 10 V is maintained across AC.

(Elect. Technology, Vikram Univ. of Ujjain)

Solution. (i) When galvanometer is removed from Fig. 2.139 (a), we get the circuit of Fig. 2.139 (b).

(ii) Let us next find the open-circuit voltage V_{oc} (also called Thevenin voltage V_{th}) between points B and D . Remembering that ABC (as well as ADC) is a potential divider on which a voltage drop of 10 V takes place, we get

$$\text{Potential of } B \text{ w.r.t. } C = 10 \times 10/110 = 10/11 = 0.909 \text{ V}$$

$$\text{Potential of } D \text{ w.r.t. } C = 10 \times 4/54 = 20/27 = 0.741 \text{ V}$$

$$\therefore \text{ p.d. between } B \text{ and } D \text{ is } V_{oc} \text{ or } V_{th} = 0.909 - 0.741 = 0.168 \text{ V}$$

(iii) Now, remove the 10-V battery retaining its internal resistance which, in this case, happens to be zero. Hence, it amounts to short-circuiting points A and C as shown in Fig. 2.139 (d).

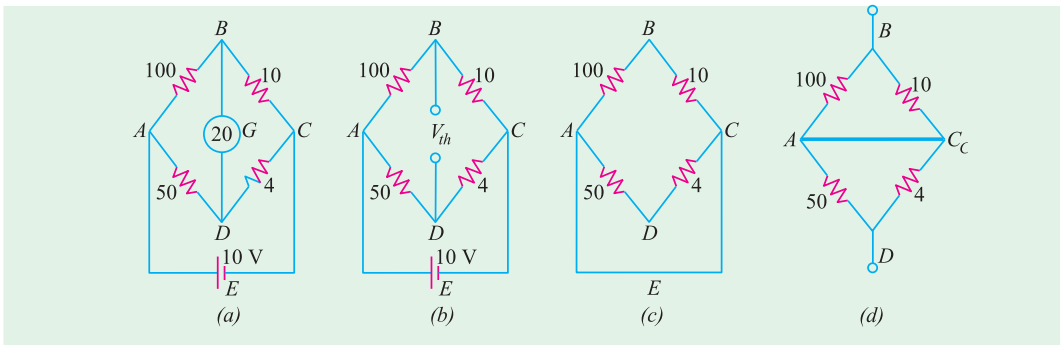

Fig. 2.139

(iv) Next, let us find the resistance of the whole network as viewed from points B and D . It may be easily found by noting that electrically speaking, points A and C have become one as shown in Fig. 2.140 (a). It is also seen that BA is in parallel with BC and AD is in parallel with CD . Hence, $R_{BD} = 10 \parallel 100 + 50 \parallel 4 = 12.79 \Omega$

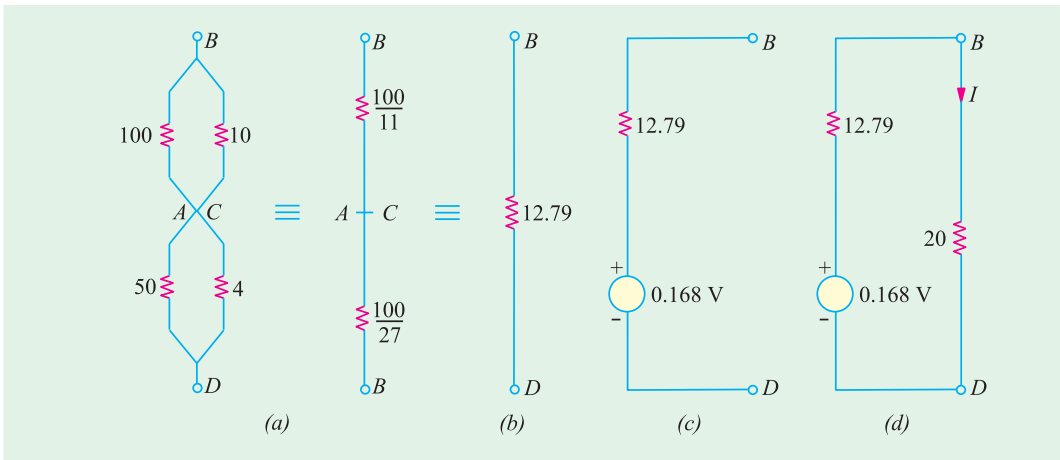

Fig. 2.140

(v) Now, so far as points B and D are connected, the network has a voltage source of 0.168 V and internal resistance $R_i = 12.79 \Omega$. This Thevenin's source is shown in Fig. 2.140 (c).

(vi) Finally, let us connect the galvanometer (initially removed) to this Thevenin source and calculate the current I flowing through it. As seen from Fig. 2.140 (d).

$$I = 0.168 / (12.79 + 20) = 0.005 \text{ A} = \mathbf{5 \text{ mA}}$$

Example 2.67. Determine the current in the $1\ \Omega$ resistor across AB of network shown in Fig. 2.141 (a) using Thevenin's theorem. (Network Analysis, Nagpur Univ. 1993)

Solution. The given circuit can be redrawn, as shown in Fig. 2.141 (b) with the $1\ \Omega$ resistor removed from terminals A and B . The current source has been converted into its equivalent voltage source as shown in Fig. 2.141 (c). For finding V_{th} , we will find the currents x and y in Fig. 2.141 (c). Applying KVL to the first loop, we get

$$3 - (3 + 2)x - 1 = 0 \quad \text{or} \quad x = 0.4\ \text{A}$$

$$\therefore V_{th} = V_{AB} = 3 - 3 \times 0.4 = 1.8\ \text{V}$$

The value of R_{th} can be found from Fig. 2.141 (c) by replacing the two voltage sources by short-circuits. In this case $R_{th} = 2 \parallel 3 = 1.2\ \Omega$

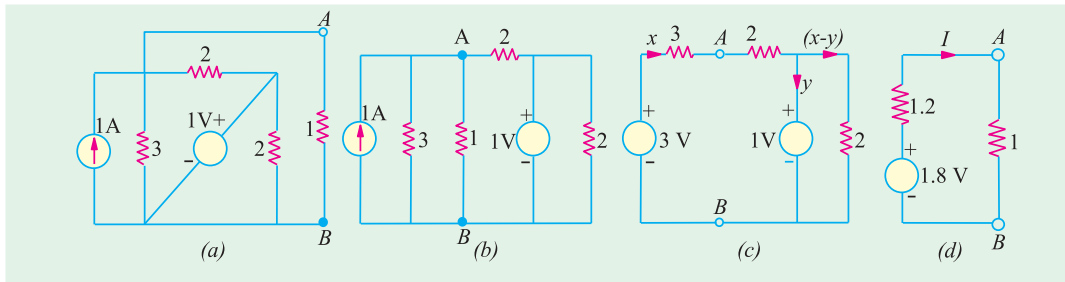

Fig. 2.141

Thevenin's equivalent circuit is shown in Fig. 2.141 (d). The current through the reconnected $1\ \Omega$ resistor is $= 1.8 / (1.2 + 1) = 0.82\ \text{A}$.

Example 2.68. Find the current flowing through the $4\ \Omega$ resistor in Fig. 2.142 (a) when (i) $E = 2\ \text{V}$ and (ii) $E = 12\ \text{V}$. All resistances are in series.

Solution. When we remove E and $4\ \Omega$ resistor, the circuit becomes as shown in Fig. 2.142 (b). For finding R_{th} i.e. the circuit resistance as viewed from terminals A and B , the battery has been short-circuited, as shown. It is seen from Fig. 2.142 (c) that $R_{th} = R_{AB} = 15 \parallel 30 + 18 \parallel 9 = 16\ \Omega$

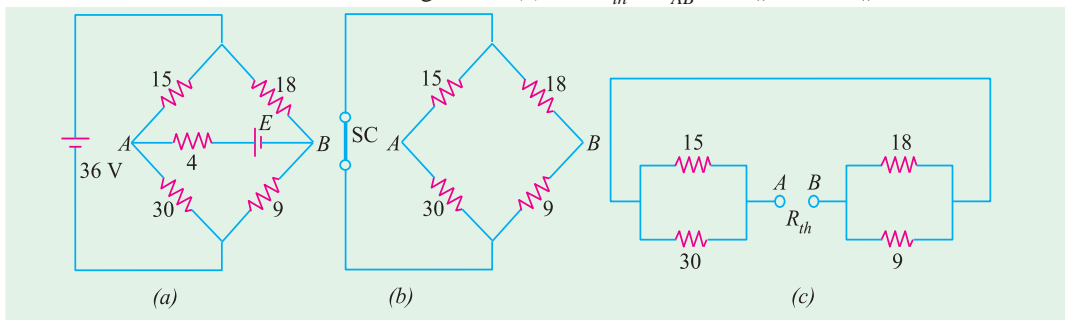

Fig. 2.142

We will find $V_{th} = V_{AB}$ with the help of Fig. 2.143 (a) which represents the original circuit, except with E and $4\ \Omega$ resistor removed. Here, the two circuits are connected in parallel across the $36\ \text{V}$ battery. The potential of point A equals the drop on $30\ \Omega$ resistance, whereas potential of point B equals the drop across $9\ \Omega$ resistance. Using the voltage,

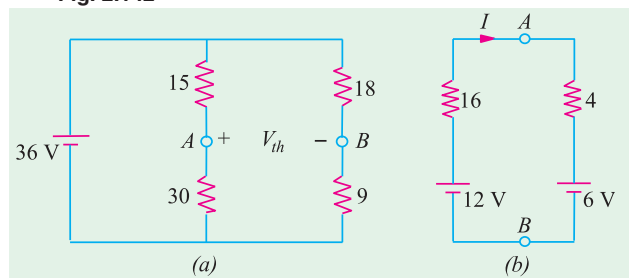

Fig. 2.143

divider rule, we have

$$V_A = 30 \times 30/45 = 24 \text{ V}$$

$$V_B = 36 \times 9/27 = 12 \text{ V}$$

$$\therefore V_{AB} = V_A - V_B = 24 - 12 = 12 \text{ V}$$

In Fig. 2.143 (b), the series combination of E and 4Ω resistors has been reconnected across terminals A and B of the Thevenin's equivalent circuit.

$$(i) I = (12 - E)/20 = (12 - 2)/20 = 0.5 \text{ A} \quad (ii) I = (12 - 12)/20 = 0$$

Example 2.69. Calculate the value of V_{th} and R_{th} between terminals A and B of the circuit shown in Fig. 2.144 (a). All resistance values are in ohms.

Solution. Forgetting about the terminal B for the time being, there are two parallel paths between E and F : one consisting of 12Ω and the other of $(4 + 8) = 12 \Omega$. Hence, $R_{EF} = 12 \parallel 12 = 6 \Omega$. The source voltage of 48 V drops across two 6Ω resistances connected in series. Hence, $V_{EF} = 24 \text{ V}$. The same 24 V acts across 12Ω resistor connected directly between E and F and across two series-connected resistance of 4Ω and 6Ω connected across E and F . Drop across 4Ω resistor $= 24 \times 4/(4 + 8) = 8 \text{ V}$ as shown in Fig. 2.144 (c).

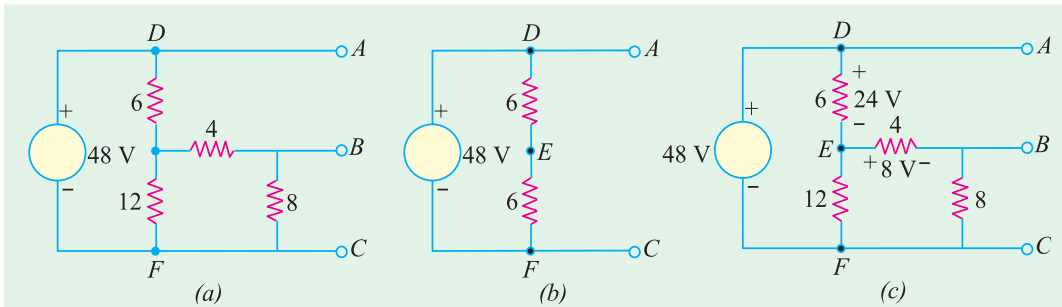

Fig. 2.144

Now, as we go from B to A via point E , there is a rise in voltage of 8 V followed by another rise in voltage of 24 V thereby giving a total voltage drop of 32 V . Hence $V_{th} = 32 \text{ V}$ with point A positive.

For finding R_{th} , we short-circuit the 48 V source. This short-circuiting, in effect, combines the points A, D and F electrically as shown in Fig. 2.145 (a). As seen from Fig. 2.145 (b),

$$R_{th} = V_{AB} = 8 \parallel (4 + 4) = 4 \Omega$$

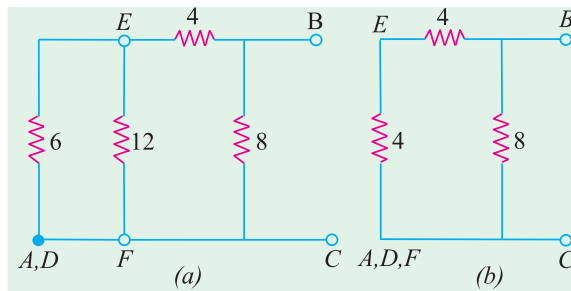

Fig. 2.145

Example 2.70. Determine Thevenin's equivalent circuit which may be used to represent the given network (Fig. 2.146) at the terminals AB .

(Electrical Eng.; Calcutta Univ.)

Solution. The given circuit of Fig. 2.146 (a) would be solved by applying Thevenin's theorem twice, first to the circuit to the left of point C and D and then to the left of points A and B . Using this technique, the network to the left of CD [Fig. 2.146 (a)] can be replaced by a source of voltage V_1 and series resistance R_{i1} as shown in Fig. 2.146 (b).

$$V_1 = \frac{12 \times 6}{(6 + 1 + 1)} = 9 \text{ volts and } R_{i1} = \frac{6 \times 2}{(6 + 2)} = 1.5 \Omega$$

Similarly, the circuit of Fig. 2.146 (b) reduced to that shown in Fig. 2.146 (c)

$$V_2 = \frac{9}{(6 + 2)} \times \frac{6}{(1.5 + 6)} = 5.68 \text{ volts and } R_{i2} = \frac{6 \times 3.5}{9.5} = 2.21$$

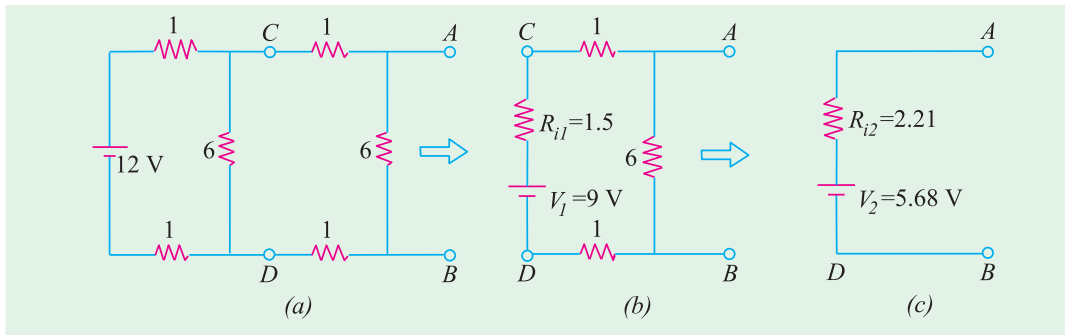

Fig. 2.146

Example 2.71. Use Thevenin's theorem, to find the value of load resistance R_L in the circuit of Fig. 2.147 (a) which results in the production of maximum power in R_L . Also, find the value of this maximum power. All resistances are in ohms.

Solution. We will remove the voltage and current sources as well as R_L from terminals A and B in order to find R_{th} as shown in Fig. 2.147 (b).

$$R_{th} = 4 + 6 \parallel 3 = 6 \Omega$$

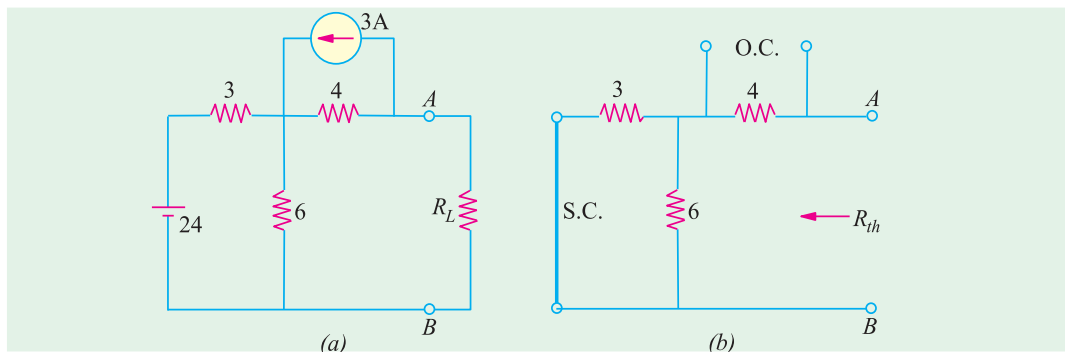

Fig. 2.147

In Fig. 2.147 (a), the current source has been converted into the equivalent voltage source for convenience. Since there is no current through the 4Ω resistance (and hence no voltage drop across it), V_{th} equals the algebraic sum of battery voltage and drop across 6Ω resistor. As we go along the path $BDCA$, we get,

$$V_{th} = 24 \times \frac{6}{6+3} - 12 = 4 \text{ V}$$

The load resistance has been reconnected to the Thevenin's equivalent circuit as shown in Fig. 2.148 (b). For maximum power transfer, $R_L = R_{th} = 6 \Omega$

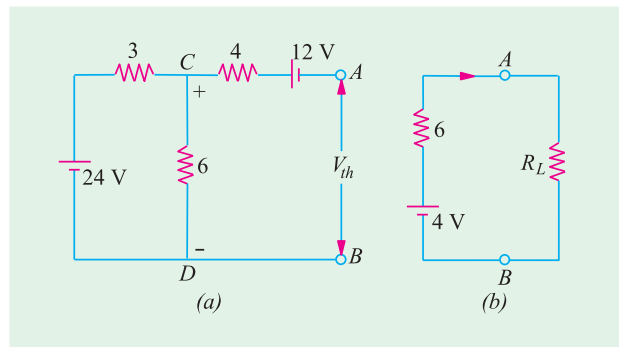

Fig. 2.148

Now,

$$V_L = \frac{1}{2} V_{th} = \frac{1}{2} \times 4 = 2 \text{ V}; P_{L \max} = \frac{V_L^2}{R_L} = \frac{2^2}{6} = 0.67 \text{ W}$$

Example 2.72. Use Thevenin's theorem to find the current flowing through the $6\ \Omega$ resistor of the network shown in Fig. 2.149 (a). All resistances are in ohms.

(Network Theory, Nagpur Univ. 1992)

Solution. When $6\ \Omega$ resistor is removed [Fig. 2.149 (b)], whole of $2\ \text{A}$ current flows along DC producing a drop of $(2 \times 2) = 4\ \text{V}$ with the polarity as shown. As we go along $BDCA$, the total voltage is

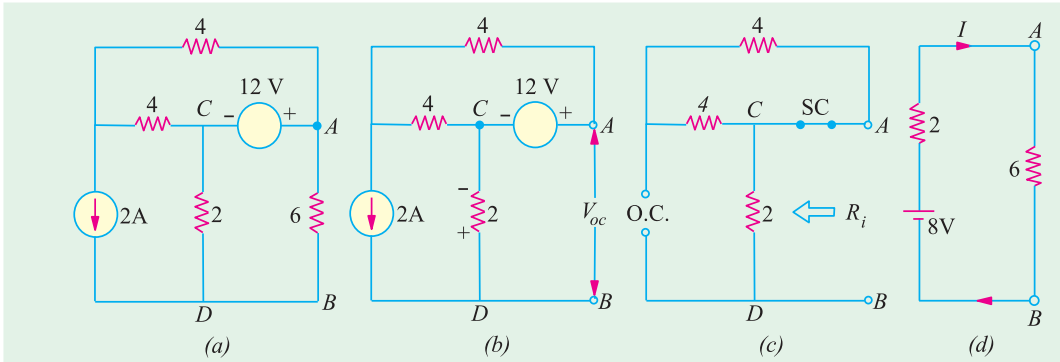

Fig. 2.149

$$= -4 + 12 = 8\ \text{V}$$

—with A positive w.r.t. B.

Hence,

$$V_{oc} = V_{th} = 8\ \text{V}$$

For finding R_i or R_{th} $18\ \text{V}$ voltage source is replaced by a short-circuit (Art- 2.15) and the current source by an open-circuit, as shown in Fig. 2.149 (c). The two $4\ \Omega$ resistors are in series and are thus equivalent to an $8\ \Omega$ resistance. However, this $8\ \Omega$ resistor is in parallel with a short of $0\ \Omega$. Hence, their equivalent value is $0\ \Omega$. Now this $0\ \Omega$ resistance is in series with the $2\ \Omega$ resistor. Hence, $R_i = 2 + 0 = 2\ \Omega$. The Thevenin's equivalent circuit is shown in Fig. 2.149 (d).

\therefore

$$I = 8/(2 + 6) = 1\ \text{Amp}$$

—from A to B

Example 2.73. Find Thevenin's equivalent circuit for the network shown in Fig. 2.150 (a) for the terminal pair AB.

Solution. It should be carefully noted that after coming to point D, the $6\ \text{A}$ current has only one path to reach its other end C i.e., through $4\ \Omega$ resistor thereby creating an IR drop of $6 \times 4 = 24\ \text{V}$ with polarity as shown in Fig. 2.150 (b). No part of it can go along DE or DF because it would not find any path back to point C. Similarly, current due to 18-V battery is restricted to loop $EDFE$. Drop across $6\ \Omega$ resistor = $18 \times 6/(6 + 3) = 12\ \text{V}$. For finding V_{AB} , let us start from A and go to B via the shortest route $ADFB$. As seen from Fig. 2.150 (b), there is a rise of $24\ \text{V}$ from A to D but a fall of $12\ \text{V}$.

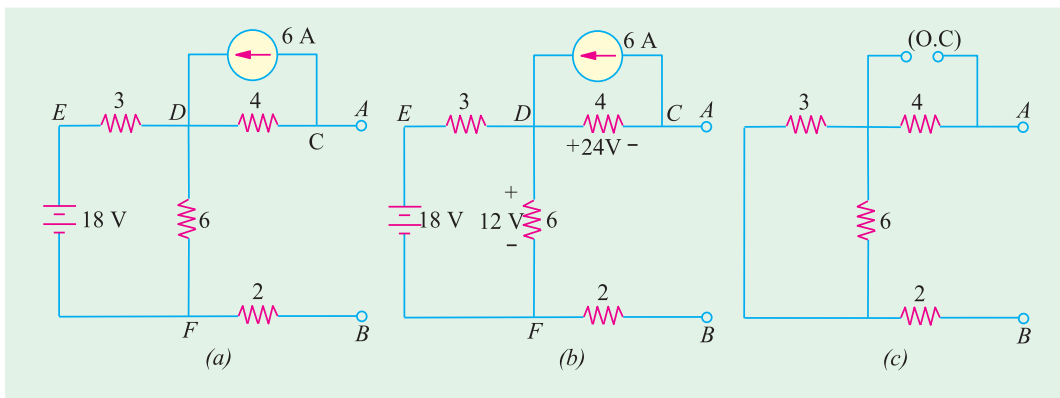

Fig. 2.150

from D to F . Hence, $V_{AB} = 24 - 12 = 12 \text{ V}$ with point A negative w.r.t. point B *. Hence, $V_{th} = V_{AB} = -12 \text{ V}$ (or $V_{BA} = 12 \text{ V}$).

For finding R_{th} , 18 V battery has been replaced by a short-circuit and 6 A current source by an open-circuit, as shown in Fig. 2.150 (c).

$$\begin{aligned} \text{As seen,} \quad R_{th} &= 4 + 6 \parallel 3 + 2 \\ &= 4 + 2 + 2 = 8 \Omega \end{aligned}$$

Hence, Thevenin's equivalent circuit for terminals A and B is as shown in Fig. 2.151. It should be noted that if a load resistor is connected across AB , current through it will flow from B to A .

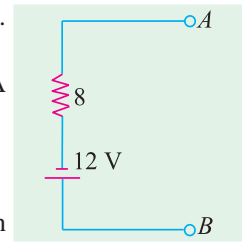

Fig. 2.151

Example 2.74. The circuit shown in Fig. 2.152 (a) contains two voltage sources and two current sources. Calculate (a) V_{th} and (b) R_{th} between the open terminals A and B of the circuit. All resistance values are in ohms.

Solution. It should be understood that since terminals A and B are open, 2 A current can flow only through 4 Ω and 10 Ω resistors, thus producing a drop of 20 V across the 10 Ω resistor, as shown in Fig. 2.152 (b). Similarly, 3 A current can flow through its own closed circuit between A and C thereby producing a drop of 24 V across 8 Ω resistor as shown in Fig. 2.152 (b). Also, there is no drop across 2 Ω resistor because no current flows through it.

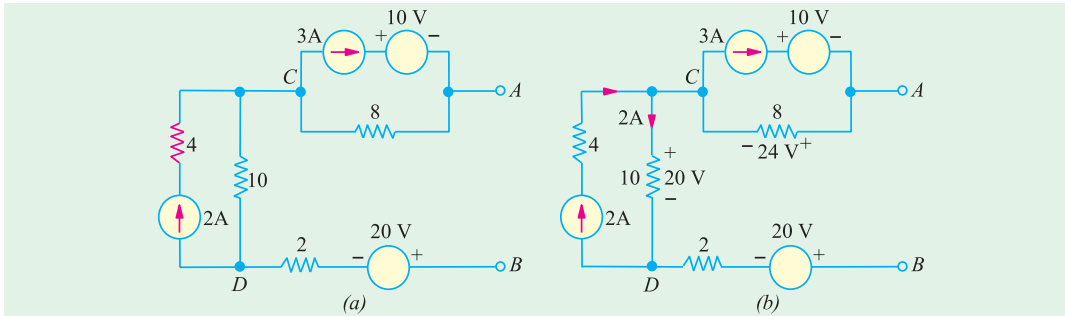

Fig. 2.152

Starting from point B and going to point A via points D and C , we get

$$V_{th} = -20 + 20 + 24 = 24 \text{ V}$$

—with point A positive.

For finding R_{th} , we will short-circuit the voltage sources and open-circuit the current sources, as shown in Fig. 2.153. As seen, $R_{th} = R_{AB} = 8 + 10 + 2 = 20 \Omega$

Example 2.75. Calculate V_{th} and R_{th} between the open terminals A and B of the circuit shown in Fig. 2.154 (a). All resistance values are in ohms.

Solution. We will convert the 48 V voltage source with its series resistance of 12 Ω into a current source of 4 A, with a parallel resistance of 12 Ω , as shown in Fig. 2.154 (b).

In Fig. 2.154 (c), the two parallel resistance of 12 Ω each have been combined into a single resistance of 6 Ω . It is obvious that 4 A current flows through the 6 Ω resistor, thereby producing a drop of $6 \times 4 = 24 \text{ V}$. Hence, $V_{th} = V_{AB} = 24 \text{ V}$ with terminal A negative. In other words $V_{th} = -24 \text{ V}$.

If we open-circuit the 8 A source and short-circuit the 48-V source in Fig. 2.154 (a), $R_{th} = R_{AB} = 12 \parallel 12 = 6 \Omega$

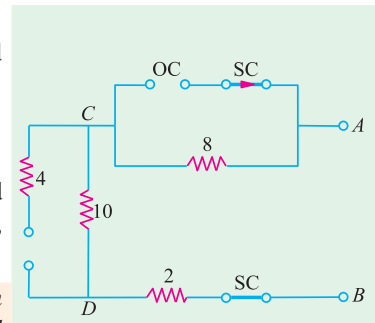

Fig. 2.153

* Incidentally, had 6 A current been flowing in the opposite direction, polarity of 24 V drop would have been reversed so that V_{AB} would have equalled $(24 + 12) = 36 \text{ V}$ with A positive w.r.t. point B .

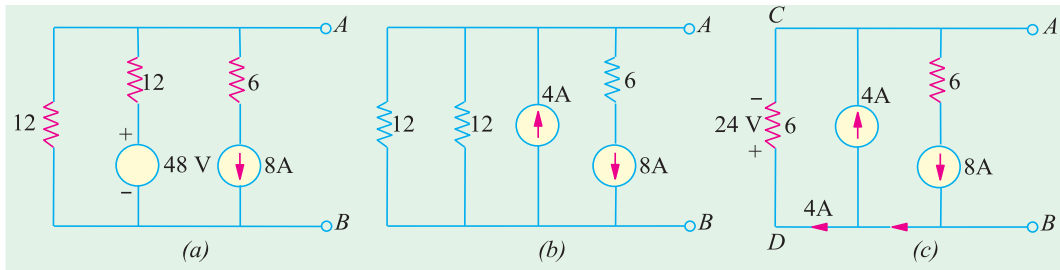

Fig. 2.154

Example 2.76. Calculate the value of V_{th} of R_{th} between the open terminals A and B of the circuit shown in Fig. 2.155 (a). All resistance values are in ohms.

Solution. It is seen from Fig. 2.155 (a) that positive end of the 24 V source has been shown connected to point A . It is understood that the negative terminal is connected to the ground terminal G . Just to make this point clear, the given circuit has been redrawn in Fig. 2.155 (b) as well as in Fig. 2.155 (c).

Let us start from the positive terminal of the battery and go to its negative terminal G via point C . We find that between points C and G , there are two parallel paths : one of $6\ \Omega$ resistance and the

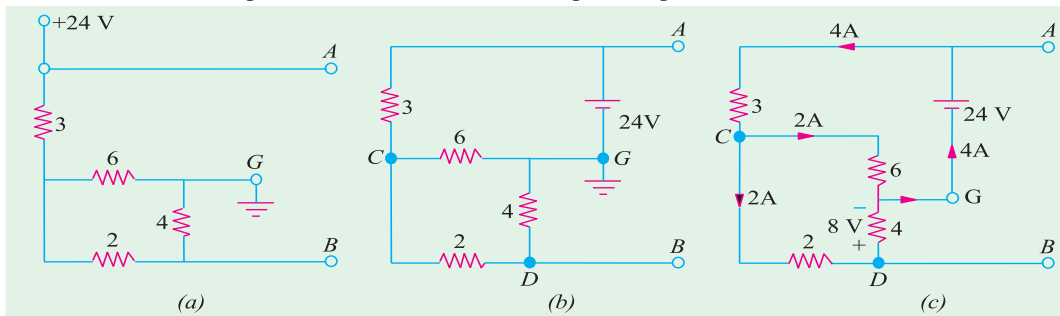

Fig. 2.155

other of $(2 + 4) = 6\ \Omega$ resistance, giving a combined resistance of $6 \parallel 6 = 3\ \Omega$. Hence, total resistance between positive and negative terminals of the battery $= 3 + 3 = 6\ \Omega$. Hence, battery current $= 24/6 = 4\ \text{A}$. As shown in Fig. 2.155 (c), this current divides equally at point C . Let us go from B to A points D and G and total up the potential difference between the two, $V_{th} = V_{AB} = -8\ \text{V} + 24\ \text{V} = 16\ \text{V}$ with point A positive.

For finding R_{th} , let us replace the voltage source by a short-circuit, as shown in Fig. 2.156 (a). It connects one end each of $6\ \Omega$ resistor and $4\ \Omega$ resistor directly to point A , as shown in Fig. 2.156 (b). The resistance of branch $DCG = 2 + 6 \parallel 3 = 4\ \Omega$. Hence $R_{th} = R_{AB} = 4 \parallel 4 = 2\ \Omega$

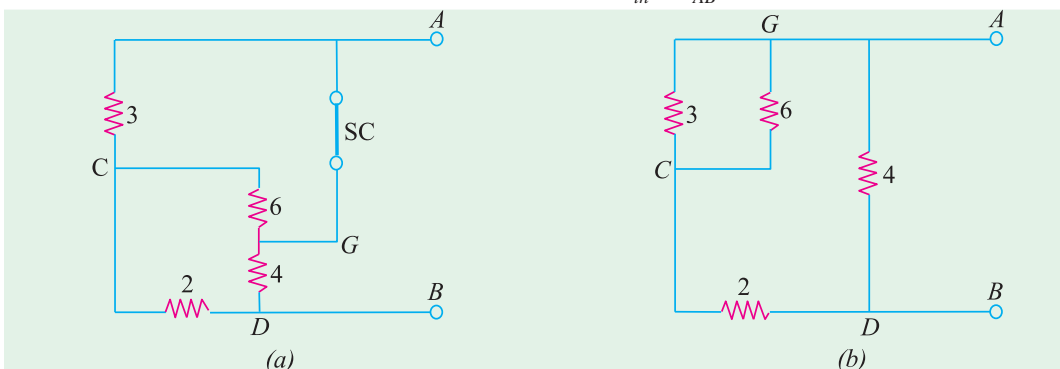

Fig. 2.156

Example 2.77. Calculate the power which would be dissipated in the 8-Ω resistor connected across terminals A and B of Fig. 2.157 (a). All resistance values are in ohms.

Solution. The open-circuit voltage V_{oc} (also called Thevenin's voltage V_{th}) is that which appears across terminals A and B. This equals the voltage drop across 10 Ω resistor between points C and D. Let us find this voltage. With AB an open-circuit, 120-V battery voltage acts on the two parallel paths EF and ECDF. Hence, current through 10 Ω resistor is

$$I = 120/(20 + 10 + 20) = 2.4 \text{ A}$$

Drop across 10-Ω resistor, $V_{th} = 10 \times 2.4 = 24 \text{ V}$

Now, let us find Thevenin's resistance R_{th} i.e. equivalent resistance of the given circuit when looked into from terminals A and B. For this purpose, 120 V battery is removed. The results in shorting the 40-Ω resistance since internal resistance of the battery is zero as shown in Fig. 2.157 (b).

$$\therefore R_i \text{ or } R_{th} = 16 + \frac{10 \times (20 + 20)}{10 + (20 + 20)} + 16 = 40 \text{ } \Omega$$

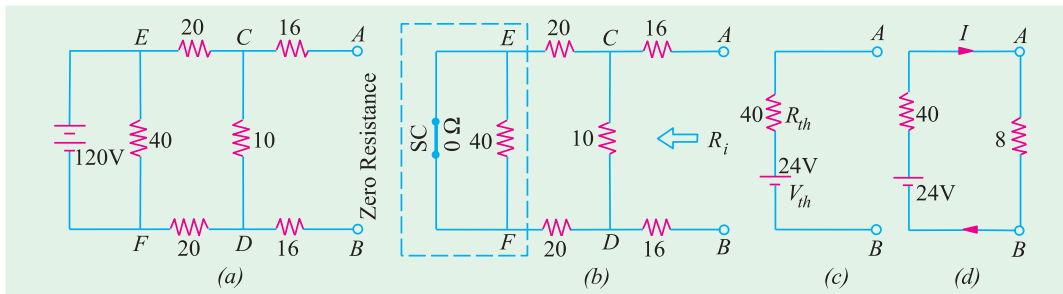

Fig. 2.157

Thevenin's equivalent circuit is shown in Fig. 2.157 (c). As shown in Fig. 2.157 (d), current through 8-Ω resistor is

$$I = 24/(40 + 8) = \frac{1}{2} \text{ A} \quad P = I^2 R = \left(\frac{1}{2}\right)^2 \times 8 = 2 \text{ W}$$

Example 2.78. With the help of Thevenin's theorem, calculate the current flowing through the 3-Ω resistor in the network of Fig. 2.158 (a). All resistances are in ohms.

Solution. The current source has been converted into an equivalent voltage source in Fig. 158 (b).

(i) **Finding V_{oc} .** As seen from Fig. 2.158 (c), $V_{oc} = V_{CD}$. In closed circuit CDFEC, net voltage = $24 - 8 = 16 \text{ V}$ and total resistance = $8 + 4 + 4 = 16 \text{ } \Omega$. Hence, current = $16/16 = 1 \text{ A}$.

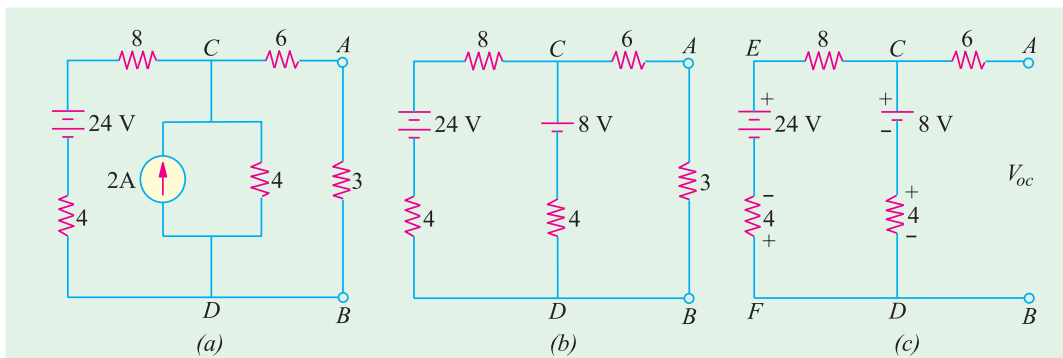

Fig. 2.158

Drop over the 4-Ω resistor in branch CD = 4 × 1 = 4 V with a polarity which is in series addition with 8-V battery.

Hence, $V_{oc} = V_{th} = V_{CD} = 8 + 4 = 12 \text{ V}$

(ii) **Finding R_i or R_{th} .** In Fig. 2.159 (a), the two batteries have been replaced by short-circuits because they do not have any internal resistance.

As seen, $R_i = 6 + 4 \parallel (8 + 4) = 9 \text{ } \Omega$

The Thevenin's equivalent circuit is as shown in Fig. 2.159 (b).

$$I = 12 / (9 + 3) = 1 \text{ A}$$

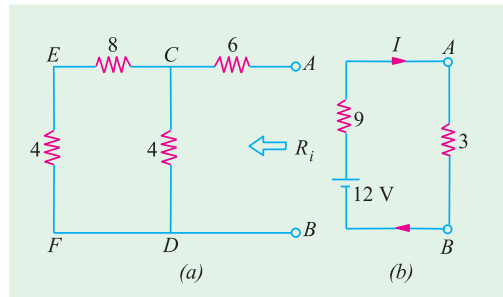

Fig. 2.159

Example 2.79. Using Thevenin and Superposition theorems find complete solution for the network shown in Fig. 2.160 (a).

Solution. First, we will find R_{th} across open terminals A and B and then find V_{th} due to the voltage sources only and then due to current source only and then using Superposition theorem, combine the two voltages to get the single V_{th} . After that, we will find the Thevenin equivalent.

In Fig. 2.160 (b), the terminals A and E have been open-circuited by removing the 10 V source and the 1 Ω resistance. Similarly, 24 V source has been replaced by a short and current source has been replaced by an infinite resistance i.e. by open-circuit. As seen, $R_{AB} = R_{th} = 4 \parallel 4 = 2 \text{ } \Omega$

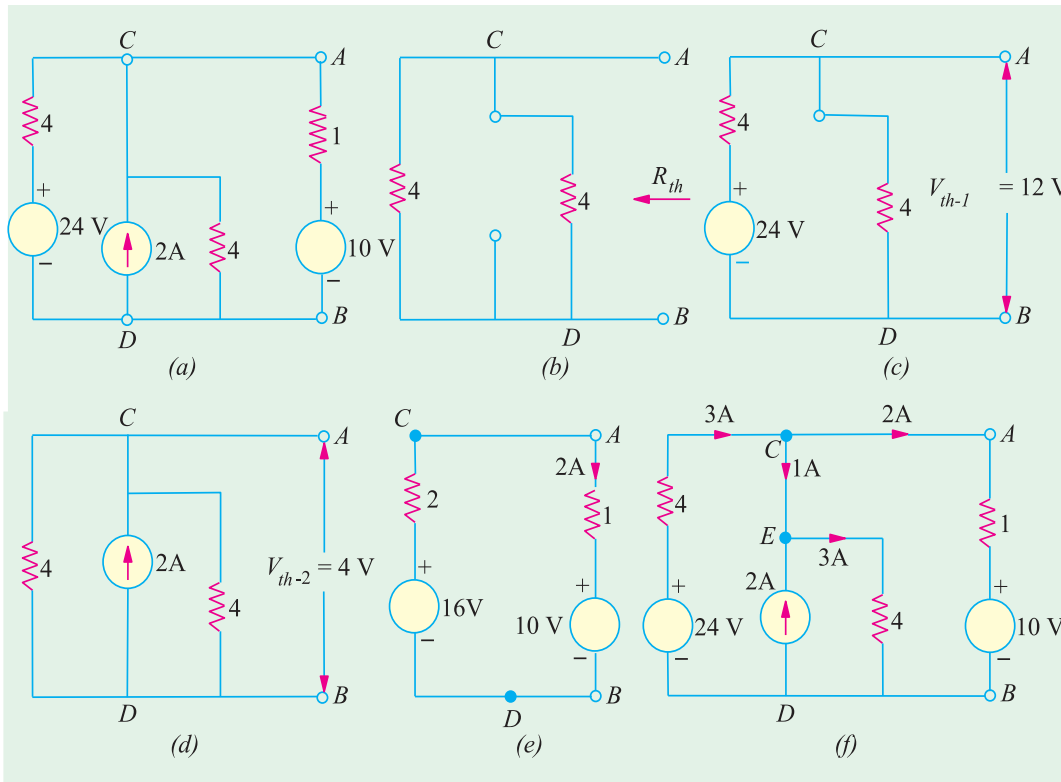

Fig. 2.160

We will now find V_{th-1} across AB due to 24 V source only by open-circuiting the current source. Using the voltage-divider rule in Fig. 2.160 (c), we get $V_{AB} = V_{CD} = V_{th-1} = 24/2 = 12$ V.

Taking only the current source and short-circuiting the 24 V source in Fig. 2.160 (d), we find that there is equal division of current at point C between the two $4\ \Omega$ parallel resistors. Therefore, $V_{th-2} = V_{AB} = V_{CD} = 1 \times 4 = 4$ V.

Using Superposition theorem, $V_{th} = V_{th-1} + V_{th-2} = 12 + 4 = 16$ V. Hence, the Thevenin's equivalent consists of a 16 V source in series with a $2\ \Omega$ resistance as shown in Fig. 2.160 (e) where the branch removed earlier has been connected back across the terminals A and B . The net voltage around the circuit is $16 - 10 = 6$ V and total resistance is $2 + 1 = 3\ \Omega$. Hence, current in the circuit is $6/3 = 2$ A. Also, $V_{AB} = V_{AD} = 16 - (2 \times 2) = 12$ V. Alternatively, V_{AB} equals $(2 \times 1) + 10 = 12$ V.

Since we know that $V_{AB} = V_{CD} = 12$ V, we can find other voltage drops and various circuit currents as shown in Fig. 2.160 (f). Current delivered by the 24-V source to the node C is $(24 - V_{CD})/4 = (24 - 12)/4 = 3$ A. Since current flowing through branch AB is 2 A, the balance of 1 A flows along CE . As seen, current flowing through the $4\ \Omega$ resistor connected across the current source is $(1 + 2) = 3$ A.

Example 2.80. Use Superposition Theorem to find I in the circuit of Fig. 2.161.

[Nagpur Univ. Summer 2001]

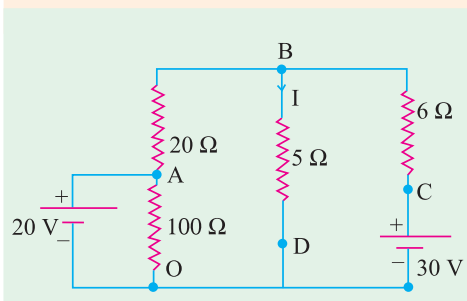

Fig. 2.161. Given Circuit

Solution. At a time, one source acts and the other is de-activated, for applying Superposition theorem. If I_1 represents the current in 5-ohm resistor due to 20-V source, and I_2 due to 30-V source,

$$I = I_1 + I_2$$

Due to 20-V source, current into node B

$$= 20/(20 + 5/6) = 0.88 \text{ amp}$$

Out of this, $I_1 = 0.88 \times 6/11 = 0.48$ amp

Due to 30-V source, current into node B

$$= 30/(6 + 5/20) = 3 \text{ amp}$$

Out of this, $I_2 = 3 \times 20/25 = 2.4$ amp

Hence, $I = 2.88$ amp

Alternatively, Thevenin's theorem can be applied at nodes BD after removing 5-ohms resistor from its position. Following the procedure to evaluate V_{TH} and R_{TH} ,

Thevenin-voltage, $V_{TH} = 27.7$ Volts

and $R_{TH} = 4.62$ Ohms

Current, $I = 27.7/(4.62 + 5) = 2.88$ amp

2.20. General Instructions for Finding Thevenin Equivalent Circuit

So far, we have considered circuits which consisted of resistors and independent current or voltage sources only. However, we often come across circuits which contain both independent and dependent sources or circuits which contain only dependent sources. Procedure for finding the value of V_{th} and R_{th} in such cases is detailed below :

(a) When Circuit Contains Both Dependent and Independent Sources

(i) The open-circuit voltage V_{oc} is determined as usual with the sources activated or 'alive'.

(ii) A short-circuit is applied across the terminals a and b and the value of short-circuit current i_{sh} is found as usual.

(iii) Thevenin resistance $R_{th} = v_{oc}/i_{sh}$. It is the same procedure as adopted for Norton's theorem. Solved examples 2.81 to 2.85 illustrate this procedure.

(b) When Circuit Contains Dependent Sources Only

(i) In this case, $v_{oc} = 0$

(ii) We connect 1 A source to the terminals a and b and calculate the value of v_{ab} .

(iii) $R_{th} = V_{ab} / 1 \Omega$

The above procedure is illustrated by solved examples.

Example 2.81. Find Thevenin equivalent circuit for the network shown in Fig. 2.162 (a) which contains a current controlled voltage source (CCVS).

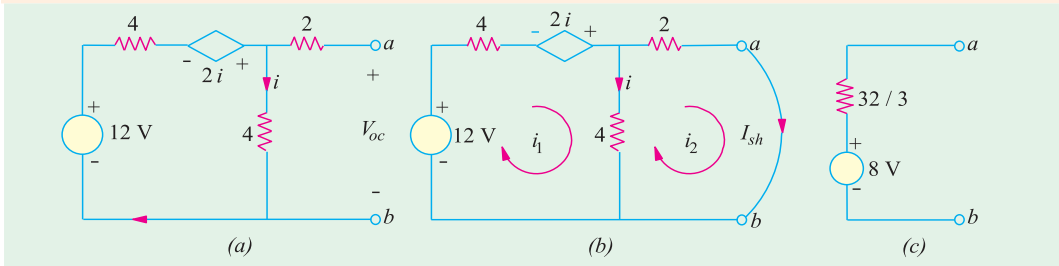

Fig. 2.162

Solution. For finding V_{oc} available across open-circuit terminals a and b , we will apply KVL to the closed loop.

$$\therefore 12 - 4i - 2i - 4i = 0 \quad \therefore i = 2 \text{ A}$$

Hence, $V_{oc} =$ drop across 4Ω resistor $= 4 \times 2 = 8 \text{ V}$. It is so because there is no current through the 2Ω resistor.

For finding R_{th} , we will put a short-circuit across terminals a and b and calculate I_{sh} , as shown in Fig. 2.162 (b). Using the two mesh currents, we have

$12 - 4i_1 + 2i - 4(i_1 - i_2) = 0$ and $-8i_2 - 4(i_2 - i_1) = 0$. Substituting $i = (i_1 - i_2)$ and Simplifying the above equations, we have

$$12 - 4i_1 + 2(i_1 - i_2) - 4(i_1 - i_2) = 0 \quad \text{or} \quad 3i_1 - i_2 = 6 \quad \dots(i)$$

Similarly, from the second equation, we get $i_1 = 3i_2$. Hence, $i_2 = 3/4$ and $R_{th} = V_{oc}/I_{sh} = 8/(3/4) = 32/3 \Omega$. The Thevenin equivalent circuit is as shown in Fig. 2.162 (c).

Example 2.82. Find the Thevenin equivalent circuit with respect to terminals a and b of the network shown in Fig. 2.163 (a).

Solution. It will be seen that with terminals a and b open, current through the 8Ω resistor is $v_{ab}/4$ and potential of point A is the same that of point a (because there is no current through 4Ω resistor). Applying KVL to the closed loop of Fig. 2.163 (a), we get

$$6 + (8 \times v_{ab}/4) - v_{ab} = 0 \quad \text{or} \quad v_{ab} = 12 \text{ V}$$

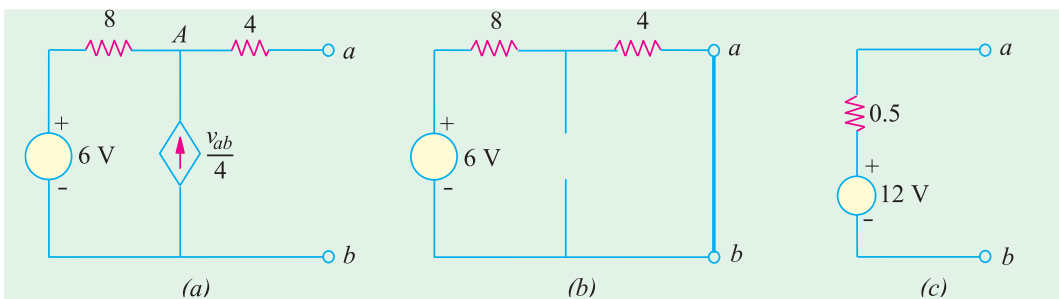

Fig. 2.163

It is also the value of the open-circuit voltage v_{oc} .

For finding short-circuit current i_{sh} , we short-circuit the terminals a and b as shown in Fig. 2.163 (b). Since with a and b short-circuited, $v_{ab} = 0$, the dependent current source also becomes zero. Hence, it is replaced by an open-circuit as shown. Going around the closed loop, we get

$$12 - i_{sh}(8 + 4) = 0 \quad \text{or} \quad i_{sh} = 6/12 = 0.5 \text{ A}$$

Hence, the Thevenin equivalent is as shown in Fig. 2.163 (c).

Example 2.83. Find the Thevenin equivalent circuit for the network shown in Fig. 2.164 (a) which contains only a dependent source.

Solution. Since circuit contains no independent source, $i = 0$ when terminals a and b are open. Hence, $v_{oc} = 0$. Moreover, i_{sh} is zero since $v_{oc} = 0$.

Consequently, R_{sh} cannot be found from the relation $R_{th} = v_{oc}/i_{sh}$. Hence, as per Art. 2.20, we will connect a 1 A current source to terminals a and b as shown in Fig. 2.164 (b). Then by finding the value of v_{ab} , we will be able to calculate $R_{th} = v_{ab}/1$.

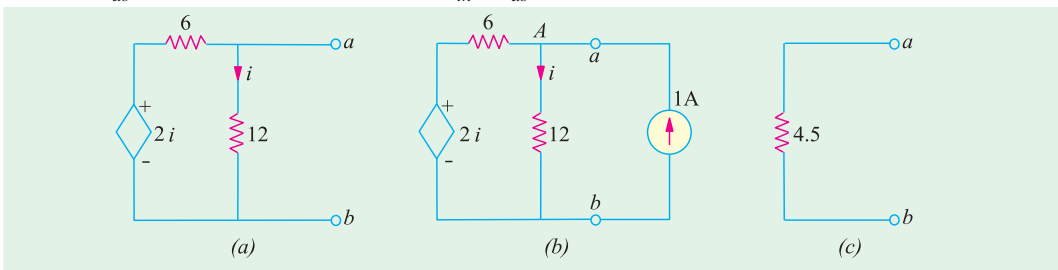

Fig. 2.164

It should be noted that potential of point A is the same as that of point a i.e. voltages across 12Ω resistor is v_{ab} . Applying KCL to point A , we get

$$\frac{2i - v_{ab}}{6} - \frac{v_{ab}}{12} + 1 = 0 \quad \text{or} \quad 4i - 3v_{ab} = -12$$

Since $i = v_{ab}/12$, we have $4(v_{ab}/12) - 3v_{ab} = -12$ or $v_{ab} = 4.5 \text{ V} \therefore R_{th} = v_{ab}/1 = 4.5/1 = 4.5 \Omega$
The Thevenin equivalent circuit is shown in Fig. 2.164 (c).

Example 2.84. Determine the Thevenin equivalent circuit as viewed from the open-circuit terminals a and b of the network shown in Fig. 2.165 (a). All resistances are in ohms.

Solution. It would be seen from Fig. 2.165(a) that potential of node A equals the open-circuit terminal voltage v_{oc} . Also, $i = (v_s - v_{oc})/(80 + 20) = (6 - v_{oc})/100$.

Applying KCL to node, A we get

$$\frac{6 - V_{oc}}{100} + \frac{9 \times (6 - v_{oc})}{100} - \frac{V_{oc}}{10} = 0 \quad \text{or} \quad V_{oc} = 3 \text{ V}$$

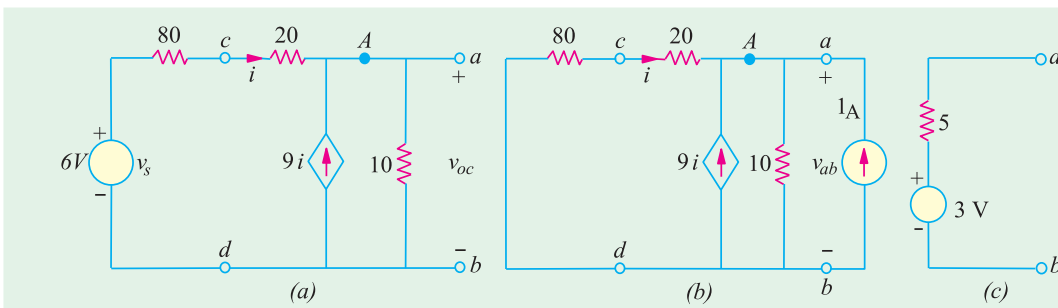

Fig. 2.165

For finding the Thevenin's resistance with respect to terminals a and b , we would first 'kill' the independent voltage source as shown in Fig. 2.165 (b). However, the dependent current source cannot be 'killed'. Next, we will connect a current source of 1 A at terminals a and b and find the value of v_{ab} . Then, Thevenin's resistance $R_{th} = v_{ab}/1$. It will be seen that current flowing away from node A i.e. from point c to d is $v_{ab}/100$. Hence, $i = -v_{oc}/100$. Applying KCL to node A , we get

$$-\frac{v_{ab}}{100} + 9 \left(-\frac{v_{ab}}{100} \right) - \frac{v_{ab}}{10} + 1 = 0 \quad \text{or} \quad v_{ab} = 5 \text{ V}$$

$\therefore R_{th} = 5/1 = 5 \Omega$. Hence, Thevenin's equivalent source is as shown in Fig. 2.165 (c).

Example 2.85. Find the Thevenin's equivalent circuit with respect to terminals a and b of the network shown in Fig. 2.166 (a). All resistances are in ohms.

Solution. It should be noted that with terminals a and b open, potential of node A equals v_{ab} . Moreover, $v = v_{ab}$. Applying KCL to node A , we get

$$-5 - \frac{v_{ab}}{15} + \frac{1}{10} \left[\left(\frac{v_{ab}}{3} + 150 \right) - v_{ab} \right] = 0 \quad \text{or} \quad v_{ab} = 75 \text{ V}$$

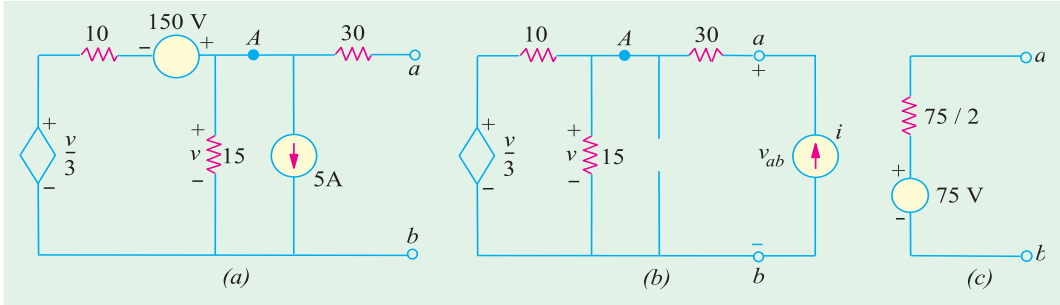

Fig. 2.166

For finding R_{th} , we will connect a current source of iA^* across terminals a and b . It should be particularly noted that in this case the potential of node A equals $(v_{ab} - 30i)$. Also, $v = (v_{ab} - 30i) =$ potential of node A , Applying KCL to node A , we get from Fig. 2.166 (b).

$$i = \frac{(v_{ab} - 30i)}{15} + \frac{1}{10} \left[\left(\frac{v_{ab} - 30i}{3} \right) - (v_{ab} - 30i) \right] = 0$$

$\therefore 4v_{ab} = 150i$ or $v_{ab}/i = 75/2 \Omega$. Hence, $R_{th} = v_{ab}/i = 75/2 \Omega$. The Thevenin's equivalent circuit is shown in Fig. 2.166 (c).

2.21. Reciprocity Theorem

It can be stated in the following manner :

In any linear bilateral network, if a source of e.m.f. E in any branch produces a current I in any other branch, then the same e.m.f. E acting in the second branch would produce the same current I in the first branch.

In other words, it simply means that E and I are mutually transferrable. The ratio E/I is known as the **transfer** resistance (or impedance in a.c. systems). Another way of stating the above is that the receiving point and the sending point in a network are interchangeable. It also means that interchange of an **ideal** voltage sources and an **ideal** ammeter in any network will not change the ammeter reading. Same is the case with the interchange of an ideal current source and an **ideal** voltmeter.

* We could also connect a source of 1 A as done in Ex. 2.83.

Example 2.86. In the network of Fig. 2.167 (a), find (a) ammeter current when battery is at A and ammeter at B and (b) when battery is at B and ammeter at point A. Values of various resistances are as shown in diagram. Also, calculate the transfer resistance.

Solution. (a) Equivalent resistance between points C and B in Fig. 2.167 (a) is

$$= 12 \times 4/16 = 3 \Omega$$

∴ Total circuit resistance

$$= 2 + 3 + 4 = 9 \Omega$$

∴ Battery current = $36/9 = 4 \text{ A}$

∴ Ammeter current

$$= 4 \times 12/16 = 3 \text{ A.}$$

(b) Equivalent resistance between points C and D in Fig. 2.167 (b) is

$$= 12 \times 6/18 = 4 \Omega$$

Total circuit resistance = $4 + 3 + 1 = 8 \Omega$

Battery current = $36/8 = 4.5 \text{ A}$

∴ Ammeter current = $4.5 \times 12/18 = 3 \text{ A}$

Hence, ammeter current in both cases is the same.

Transfer resistance = $36/3 = 12 \Omega$

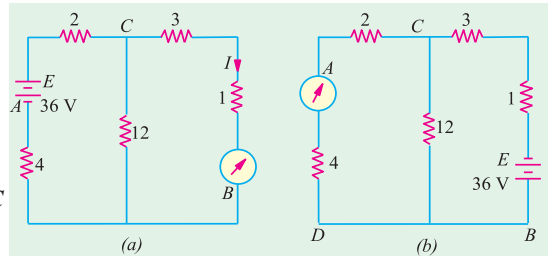

Fig. 2.167

Example 2.87. Calculate the currents in the various branches of the network shown in Fig. 2.168 and then utilize the principle of Superposition and Reciprocity theorem together to find the value of the current in the 1-volt battery circuit when an e.m.f. of 2 volts is added in branch BD opposing the flow of original current in that branch.

Solution. Let the currents in the various branches be as shown in the figure. Applying Kirchoff's second law, we have

For loop ABDA ; $-2I_1 - 8I_3 + 6I_2 = 0$ or $I_1 - 3I_2 + 4I_3 = 0$...**(i)**

For loop BCDB, $-4(I_1 - I_3) + 5(I_2 + I_3) + 8I_3 = 0$ or $4I_1 - 5I_2 - 17I_3 = 0$...**(ii)**

For loop ABCEA, $-2I_1 - 4(I_1 - I_3) - 10(I_1 + I_2) + 1 = 0$ or $16I_1 + 10I_2 - 4I_3 = 1$...**(iii)**

Solving for I_1, I_2 and I_3 , we get $I_1 = 0.494 \text{ A}; I_2 = 0.0229 \text{ A}; I_3 = 0.0049 \text{ A}$

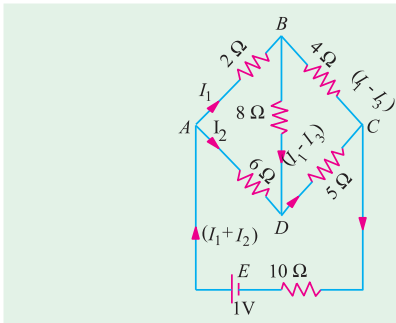

Fig. 2.168

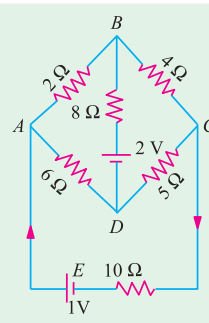

Fig. 2.169

∴ Current in the 1 volt battery circuit is $I_1 + I_2 = 0.0723 \text{ A}$.

The new circuit having 2 - V battery connected in the branch BD is shown in Fig. 2.169. According to the Principle of Superposition, the new current in the 1 - volt battery circuit is due to the superposition of two currents; one due to 1 - volt battery and the other due to the 2 - volt battery when each acts independently.

The current in the external circuit due to 1 - volt battery when 2 - volt battery is not there, as found above, is 0.0723 A.

Now, according to Reciprocity theorem; if 1 - volt battery were transferred to the branch *BD* (where it produced a current of 0.0049 A), then it would produce a current of 0.0049 A in the branch *CEA* (where it was before). Hence, a battery of 2 - V would produce a current of $(-2 \times 0.0049) = -0.0098$ A (by proportion). The negative sign is used because the 2 - volt battery has been so connected as to oppose the current in branch *BD*,

$$\therefore \text{new current in branch } CEA = 0.0723 - 0.0098 = \mathbf{0.0625 \text{ A}}$$

Tutorial Problems No. 2.5

1. Calculate the current in the 8-W resistor of Fig. 2.170 by using Thevenin's theorem. What will be its value of connections of 6-V battery are reversed? [0.8 A ; 0 A]
2. Use Thevenin's theorem to calculate the p.d. across terminals *A* and *B* in Fig. 2.171. [1.5 V]

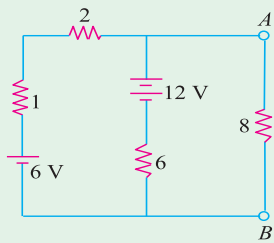

Fig. 2.170

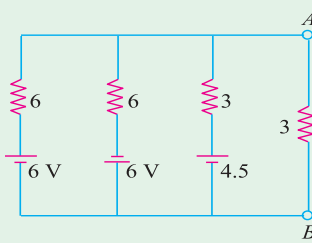

Fig. 2.171

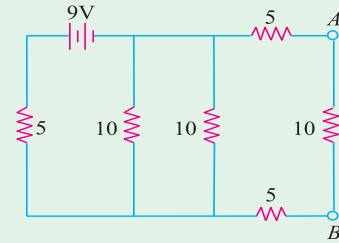

Fig. 2.172

3. Compute the current flowing through the load resistance of 10 Ω connected across terminals *A* and *B* in Fig. 2.172 by using Thevenin's theorem.
4. Find the equivalent Thevenin voltage and equivalent Thevenin resistance respectively as seen from open-circuited terminals *A* and *B* to the circuits shown in Fig. 2.173. All resistances are in ohms.

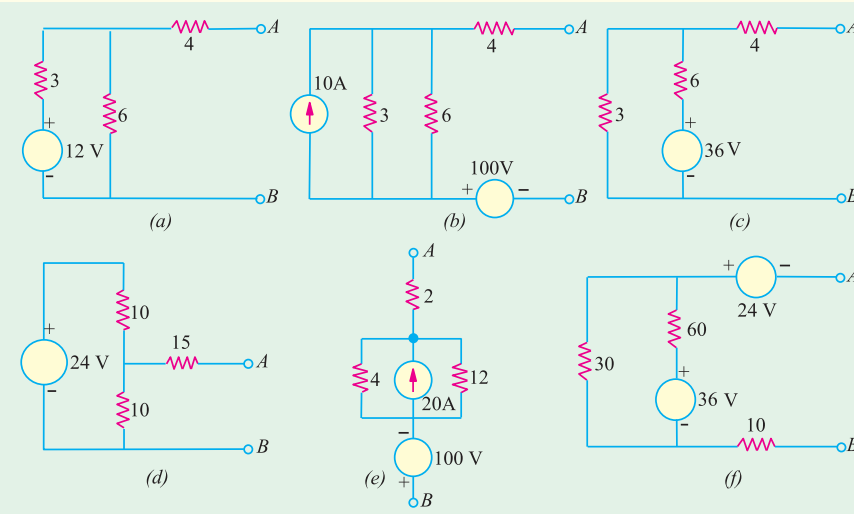

Fig. 2.173

[(a) 8 V, 6 Ω; (b) 120 V, 6 Ω; (c) 12 V, 6 Ω; (d) 12 V, 20 Ω; (e) -40 V, 5 Ω; (f) -12 V, 30 Ω]

5. Find Thevenin's equivalent of the circuits shown in Fig. 2.174 between terminals *A* and *B*.

$$[(a) V_{th} = I \frac{R_1 R_2}{R_1 + R_2} + V \frac{R_2}{R_1 + R_2}; R_{th} = \frac{R_1 R_2}{R_1 + R_2} \quad (b) V_{th} = \frac{V_1 R_2 + V_2 R_1}{R_1 + R_2}; R_{th} = \frac{R_1 R_2}{R_1 + R_2}$$

$$(c) V_{th} = -IR; R_{th} = R_1 \quad (d) V_{th} = -V_1 - IR, R_{th} = R \quad (e) \text{ Not possible}]$$

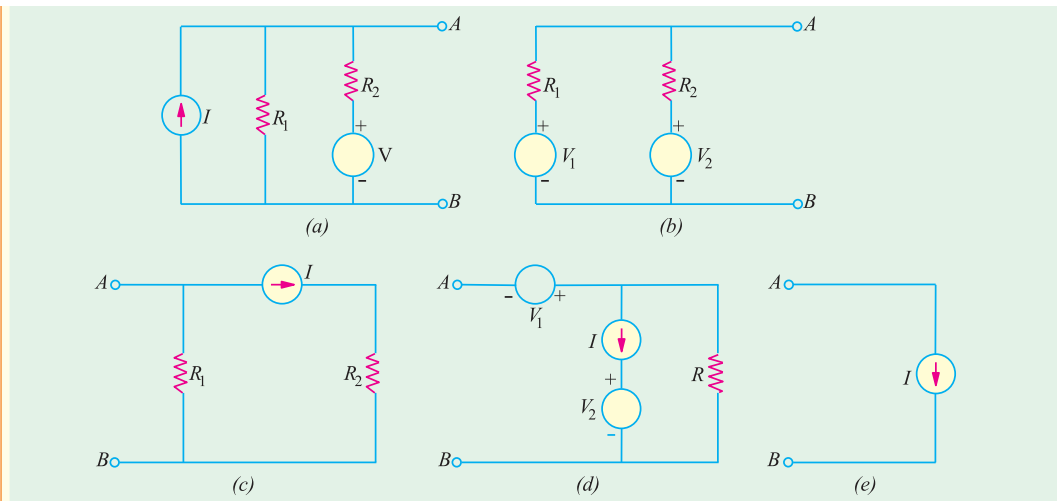

Fig. 2.174

6. The four arms of a Wheatstone bridge have the following resistances in ohms.

$$AB = 100, BC = 10, CD = 5, DA = 60$$

A galvanometer of 15 ohm resistance is connected across BD . Calculate the current through the galvanometer when a potential difference of 10 V is maintained across AC .

[Elect. Engg. A.M.Ae. S.I.Dec. 1991] [4.88 mA]

7. Find the Thevenin equivalent circuit for the network shown in Fig. 2.175.

[(a) 4 V; 8 Ω (b) 6 V; 3 Ω (c) 0V; 2/5 Ω]

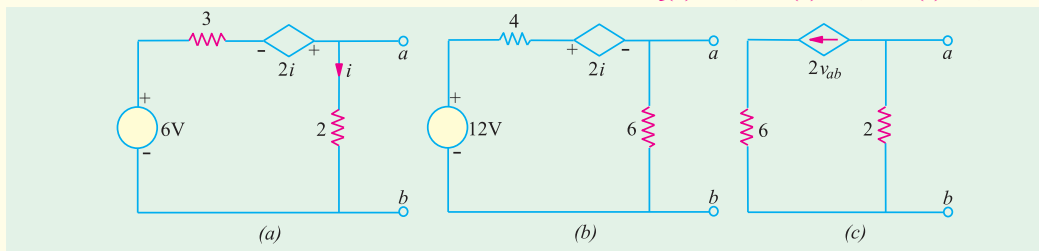

Fig. 2.175

8. Use Thevenin's theorem to find current in the branch AB of the network shown in Fig. 2.176.

[1.84 A]

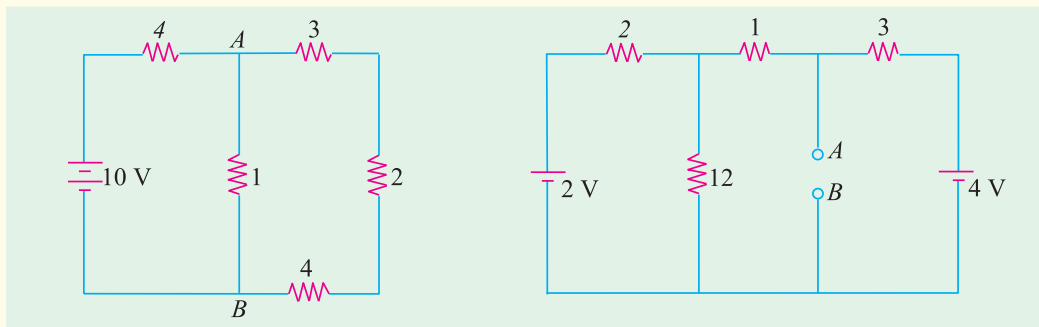

Fig. 2.176

Fig. 2.177

9. In the network shown in Fig. 2.177 find the current that would flow if a $2\text{-}\Omega$ resistor was connected between points A and B by using.

(a) Thevenin's theorem and (b) Superposition theorem. The two batteries have negligible resistance.

[0.82 A]

10. State and explain Thevenin's theorem. By applying Thevenin's theorem or otherwise, find the current through the resistance R and the voltage across it when connected as shown in Fig. 2.178.

[60.49 A, 600.49 V] (*Elect. and Mech. Technology, Osmania Univ.*)

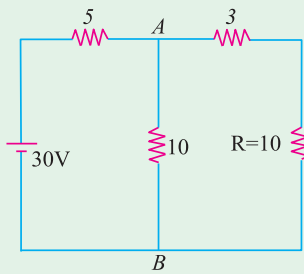

Fig. 2.178

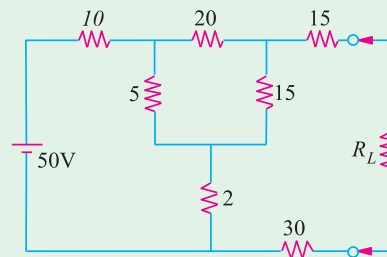

Fig. 2.179

11. State and explain Thevenin's theorem.

For the circuit shown in Fig. 2.179, determine the current through R_L when its value is $50\ \Omega$. Find the value of R_L for which the power drawn from the source is maximum.

(*Elect. Technology I, Gwalior Univ.*)

12. Find the Thevenin's equivalent circuit for terminal pair AB for the network shown in Fig. 2.180.

[$V_{th} = -16\text{ V}$ and $R_{th} = 16\ \Omega$]

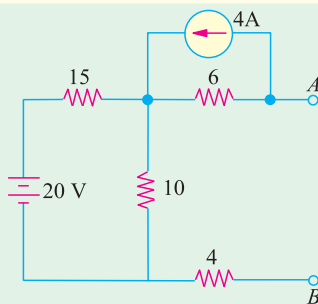

Fig. 2.180

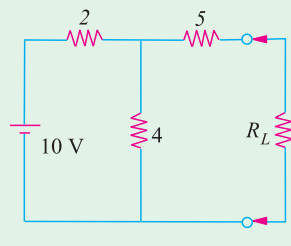

Fig. 2.181

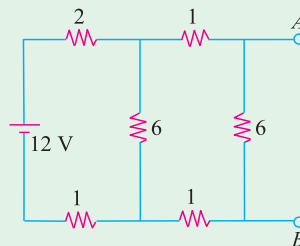

Fig. 2.182

13. For the circuit shown in Fig. 2.181, determine current through R_L when it takes values of 5 and 10 Ω .

[0.588 A, 0.408 A] (*Network Theorem and Fields, Madras Univ.*)

14. Determine Thevenin's equivalent circuit which may be used to represent the network of Fig. 2.182 at the terminals AB .

[$V_{th} = 4.8\text{ V}$, $R_{th} = 2.4\ \Omega$]

15. For the circuit shown in Fig. 2.183 find Thevenin's equivalent circuit for terminal pair AB .

[6 V, 6 Ω]

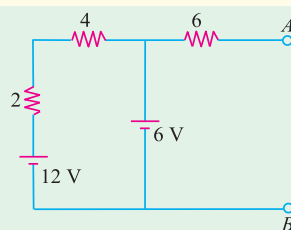

Fig. 2.183

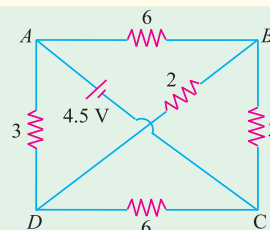

Fig. 2.184

16. ABCD is a rectangle whose opposite side AB and DC represent resistances of $6\ \Omega$ each, while AD and BC represent $3\ \Omega$ each. A battery of e.m.f. 4.5 V and negligible resistances is connected between diagonal points A and C and a $2\text{-}\Omega$ resistance between B and D. Find the magnitude and direction of the current in the 2-ohm resistor by using Thevenin's theorem. The positive terminal is connected to A. (Fig. 2.184) [0.25 A from D to B] (*Basic Electricity Bombay Univ.*)

2.22. Delta/Star* Transformation

In solving networks (having considerable number of branches) by the application of Kirchhoff's Laws, one sometimes experiences great difficulty due to a large number of simultaneous equations that have to be solved. However, such complicated network can be simplified by successively replacing delta meshes by equivalent star system and *vice versa*.

Suppose we are given three resistances R_{12} , R_{23} and R_{31} connected in delta fashion between terminals 1, 2 and 3 as in Fig. 2.185 (a). So far as the respective terminals are concerned, these three given resistances can be replaced by the three resistances R_1 , R_2 and R_3 connected in star as shown in Fig. 2.185 (b).

These two arrangements will be electrically equivalent if the resistance as measured between any pair of terminals is the same in both the arrangements. Let us find this condition.

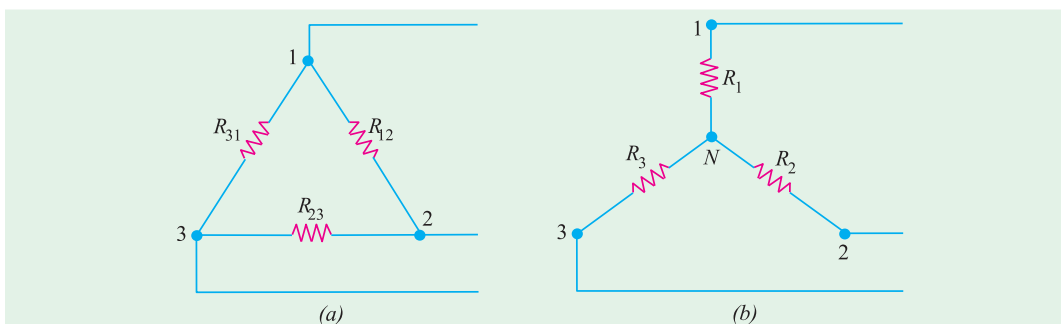

Fig. 2.185

First, take delta connection : Between terminals 1 and 2, there are two parallel paths; one having a resistance of R_{12} and the other having a resistance of $(R_{12} + R_{31})$.

$$\therefore \text{Resistance between terminals 1 and 2 is } = \frac{R_{12} \times (R_{23} + R_{31})}{R_{12} + (R_{23} + R_{31})}$$

Now, take star connection : The resistance between the same terminals 1 and 2 is $(R_1 + R_2)$.

As terminal resistances have to be the same

$$\therefore R_1 + R_2 = \frac{R_{12} \times (R_{23} + R_{31})}{R_{12} + R_{23} + R_{31}} \quad \dots (i)$$

Similarly, for terminals 2 and 3 and terminals 3 and 1, we get

$$R_2 + R_3 = \frac{R_{23} \times (R_{31} + R_{12})}{R_{12} + R_{23} + R_{31}} \quad \dots (ii)$$

$$\text{and } R_3 + R_1 = \frac{R_{31} \times (R_{12} + R_{23})}{R_{12} + R_{23} + R_{31}} \quad \dots (iii)$$

Now, subtracting (ii) from (i) and adding the result to (iii), we get

$$R_1 = \frac{R_{12} R_{31}}{R_{12} + R_{23} + R_{31}}; R_2 = \frac{R_{23} R_{12}}{R_{12} + R_{23} + R_{31}} \text{ and } R_3 = \frac{R_{31} R_{23}}{R_{12} + R_{23} + R_{31}}$$

* In Electronics, star and delta circuits are generally referred to as T and π circuits respectively.

How to Remember ?

It is seen from above that each numerator is the product of the two sides of the delta which meet at the point in star. Hence, it should be remembered that : *resistance of each arm of the star is given by the product of the resistances of the two delta sides that meet at its end divided by the sum of the three delta resistances.*

2.23. Star/Delta Transformation

This transformation can be easily done by using equations (i), (ii) and (iii) given above. Multiplying (i) and (ii), (ii) and (iii), (iii) and (i) and adding them together and then simplifying them, we get

$$R_{12} = \frac{R_1 R_2 + R_2 R_3 + R_3 R_1}{R_3} = R_1 + R_2 + \frac{R_1 R_2}{R_3}$$

$$R_{23} = \frac{R_1 R_2 + R_2 R_3 + R_3 R_1}{R_1} = R_2 + R_3 + \frac{R_2 R_3}{R_1}$$

$$R_{31} = \frac{R_1 R_2 + R_2 R_3 + R_3 R_1}{R_2} = R_1 + R_3 + \frac{R_3 R_1}{R_2}$$

How to Remember ?

The equivalent delta resistance between any two terminals is given by the sum of star resistances between those terminals plus the product of these two star resistances divide by the third star resistances.

Example 2.88. Find the input resistance of the circuit between the points A and B of Fig 2.186(a).
(AMIE Sec. B Network Analysis Summer 1992)

Solution. For finding R_{AB} , we will convert the delta CDE of Fig. 2.186 (a) into its equivalent star as shown in Fig. 2.186 (b).

$$R_{CS} = 8 \times 4/18 = 16/9 \Omega; \quad R_{ES} = 8 \times 6/18 = 24/9 \Omega; \quad R_{DS} = 6 \times 4/18 = 12/9 \Omega$$

The two parallel resistances between S and B can be reduced to a single resistance of $35/9 \Omega$

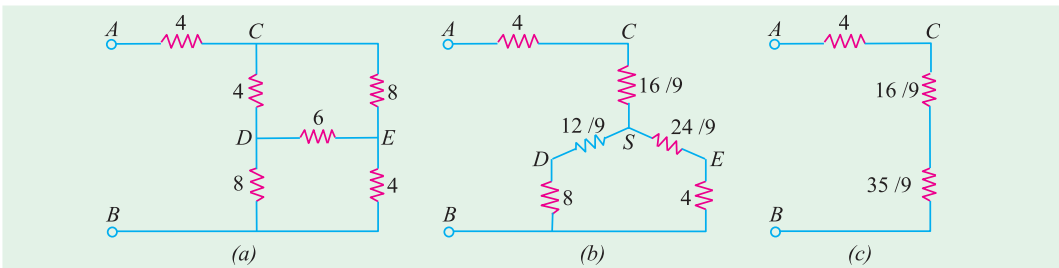

Fig 2.186

As seen from Fig. 2.186 (c), $R_{AB} = 4 + (16/9) + (35/9) = 87/9 \Omega$

Example 2.89. Calculate the equivalent resistance between the terminals A and B in the network shown in Fig. 2.187 (a).
(F.Y. Engg. Pune Univ.)

Solution. The given circuit can be redrawn as shown in Fig. 2.187 (b). When the delta BCD is converted to its equivalent star, the circuit becomes as shown in Fig. 2.187 (c).

Each arm of the delta has a resistance of 10Ω . Hence, each arm of the equivalent star has a resistance $= 10 \times 10/30 = 10/3 \Omega$. As seen, there are two parallel paths between points A and N, each having a resistance of $(10 + 10/3) = 40/3 \Omega$. Their combined resistance is $20/3 \Omega$. Hence, $R_{AB} = (20/3) + 10/3 = 10 \Omega$

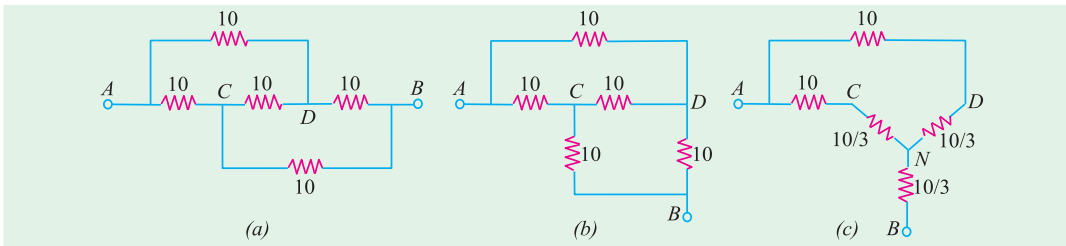

Fig. 2.187

Example 2.90. Calculate the current flowing through the $10\ \Omega$ resistor of Fig. 2.188 (a) by using any method. (Network Theory, Nagpur Univ. 1993)

Solution. It will be seen that there are two deltas in the circuit i.e. ABC and DEF . They have been converted into their equivalent stars as shown in Fig. 2.188 (b). Each arm of the delta ABC has a resistance of $12\ \Omega$ and each arm of the equivalent star has a resistance of $4\ \Omega$. Similarly, each arm of the delta DEF has a resistance of $30\ \Omega$ and the equivalent star has a resistance of $10\ \Omega$ per arm.

The total circuit resistance between A and $F = 4 + 48 \parallel 24 + 10 = 30\ \Omega$. Hence $I = 180/30 = 6\ \text{A}$. Current through $10\ \Omega$ resistor as given by current-divider rule = $6 \times 48/(48 + 24) = 4\ \text{A}$.

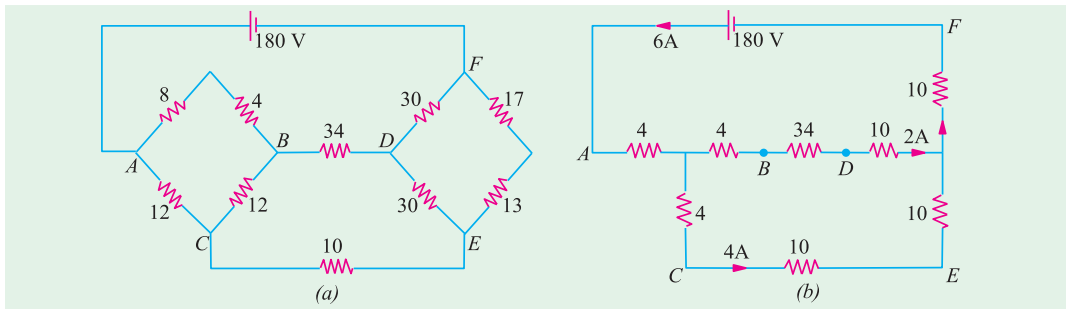

Fig. 2.188

Example 2.91. A bridge network $ABCD$ has arms AB , BC , CD and DA of resistances 1 , 1 , 2 and 1 ohm respectively. If the detector AC has a resistance of 1 ohm, determine by star/delta transformation, the network resistance as viewed from the battery terminals. (Basic Electricity, Bombay Univ.)

(Basic Electricity, Bombay Univ.)

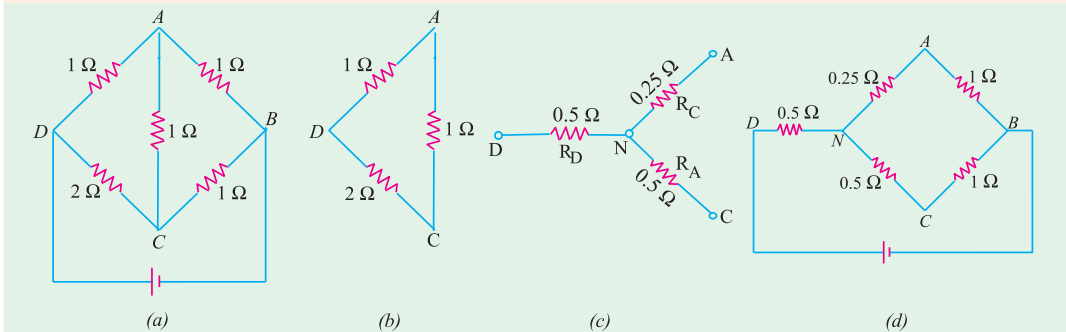

Fig. 2.189

Solution. As shown in Fig. 2.189 (b), delta DAC has been reduced to its equivalent star.

$$R_D = \frac{2 \times 1}{2 + 1 + 1} = 0.5\ \Omega, \quad R_A = \frac{1}{4} = 0.25\ \Omega, \quad R_C = \frac{2}{4} = 0.5\ \Omega$$

Hence, the original network of Fig. 2.189 (a) is reduced to the one shown in Fig. 2.189 (d). As seen, there are two parallel paths between points N and B , one of resistance 1.25Ω and the other of resistance 1.5Ω . Their combined resistance is

$$= \frac{1.25 \times 1.5}{1.25 + 1.5} = \frac{15}{22} \Omega$$

Total resistance of the network between points D and B is

$$= 0.5 \frac{15}{22} = \frac{13}{11} \Omega$$

Example 2.92. A network of resistances is formed as follows as in Fig. 2.190 (a)

$AB = 9 \Omega$; $BC = 1 \Omega$; $CA = 1.5 \Omega$ forming a delta and $AD = 6 \Omega$; $BD = 4 \Omega$ and $CD = 3 \Omega$ forming a star. Compute the network resistance measured between (i) A and B (ii) B and C and (iii) C and A . (Basic Electricity, Bombay Univ. 1980)

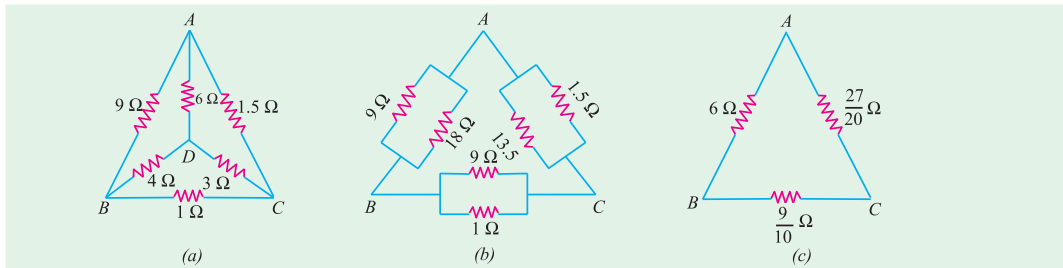

Fig. 2.190

Solution. The star of Fig. 2.190 (a) may be converted into the equivalent delta and combined in parallel with the given delta ABC . Using the rule given in Art. 2.22, the three equivalent delta resistance of the given star become as shown in Fig. 2.190 (b).

When combined together, the final circuit is as shown in Fig. 2.190 (c).

(i) As seen, there are two parallel paths across points A and B .

(a) one directly from A to B having a resistance of 6Ω and

(b) the other via C having a total resistance

$$= \frac{27}{20} \frac{9}{10} = 2.25 \quad R_{AB} = \frac{6}{(6 + 2.25)} = \frac{18}{11} \Omega$$

$$(ii) \quad R_{BC} = \frac{\frac{9}{10}}{\frac{9}{10} + 6 + \frac{27}{20}} = \frac{441}{550} \Omega \quad (iii) \quad R_{CA} = \frac{\frac{27}{20}}{\frac{9}{10} + 6 + \frac{27}{20}} = \frac{621}{550} \Omega$$

Example 2.93. State Norton's theorem and find current using Norton's theorem through a load of 8Ω in the circuit shown in Fig. 2.191(a). (Circuit and Field Theory, A.M.I.E. Sec. B, 1993)

Solution. In Fig. 2.191 (b), load impedance has replaced by a short-circuit.

$$I_{SC} = I_N = 200/2 = 100 \text{ A.}$$

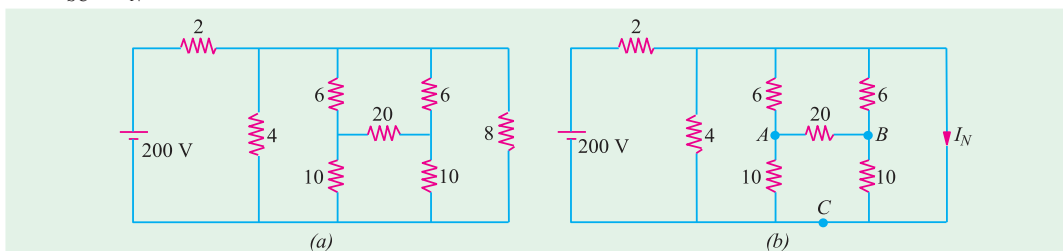

Fig. 2.191

Norton's resistance R_N can be found by looking into the open terminals of Fig. 2.191 (a). For this purpose ΔABC has been replaced by its equivalent Star. As seen, R_N is equal to $8/7 \Omega$

Hence, Norton's equivalent circuit consists of a 100 A source having a parallel resistance of $8/7 \Omega$ as shown in Fig. 2.192 (c). The load current I_L can be found by using the Current Divider rule.

$$I_L = 100 \times \frac{(8/7)}{8 + (8/7)} = 12.5 \text{ A}$$

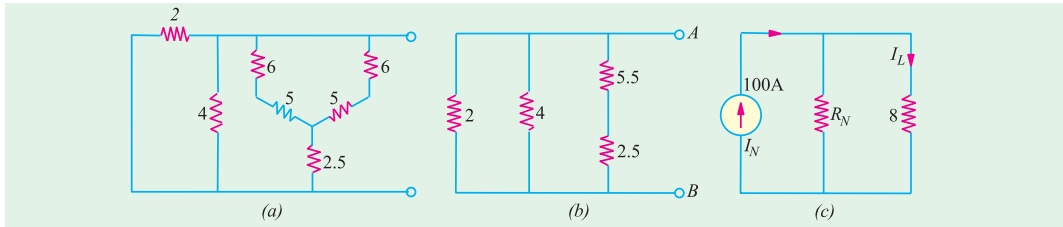

Fig. 2.192

Example 2.94. Use delta-star conversion to find resistance between terminals 'AB' of the circuit shown in Fig. 2.193 (a). All resistances are in ohms. [Nagpur University April 1999]

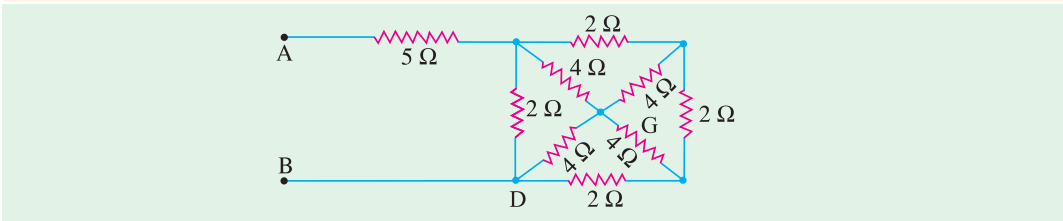

Fig. 2.193 (a)

Solution. First apply delta-star conversion to CGD and EDF, so as to redraw the part of the circuit with new configuration, as in Fig. 2.193 (b).

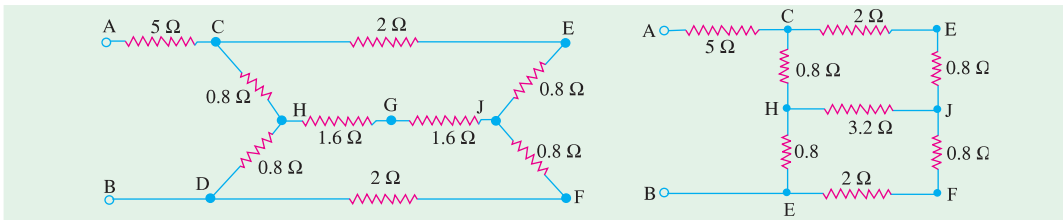

Fig. 2.193 (b)

Fig. 2.193 (c)

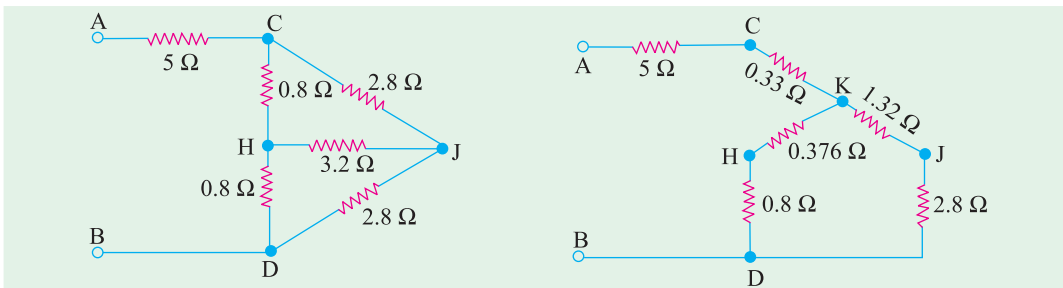

Fig. 2.193 (d)

Fig. 2.193 (e)

Simplify to reduce the circuit to its equivalents as in Fig. 2.193 (c) and later as in Fig. 2.193 (d). Convert CHJ to its equivalent star as in Fig. 2.193 (e). With the help of series-parallel combinations, calculate R_{AD} as

$$R_{AB} = 5.33 + (1.176 \times 4.12/5.296) = 6.245 \text{ ohms}$$

Note : Alternatively, after simplification as in Fig. (d). “CDJ – H” star-configuration can be transformed into delta. Node H then will not exist. The circuit has the parameters as shown in Fig. 2.193 (f). Now the resistance between C and J (and also between D and J) is a parallel combination of 7.2 and 2.8 ohms, which 2.016 ohms. Along CJD, the resistance between terminals AB then obtained as :

$$\begin{aligned} R_{AB} &= 5.0 + (1.8 \times 4.032/5.832) \\ &= 5.0 + 1.244 = 6.244 \text{ ohms} \end{aligned}$$

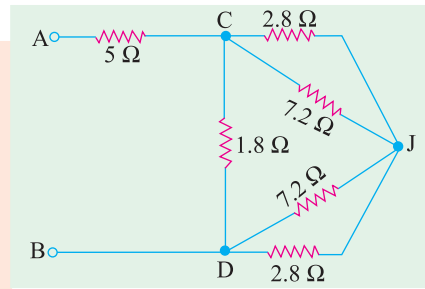

Fig. 2.193 (f)

Example 2.94 (a). Find the resistance at the A-B terminals in the electric circuit of Fig. 2.193 (g) using Δ -Y transformation. [U.P. Technical University, 2001]

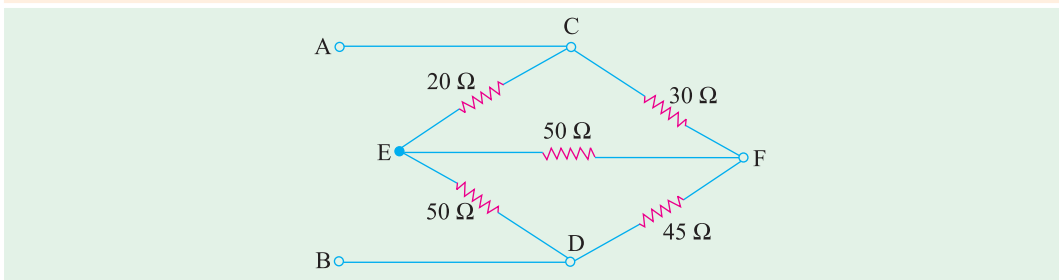

Fig. 2.193 (g)

Solution. Convert delta to star for nodes C, E, F. New node N is created. Using the formulae for this conversion, the resistances are evaluated as marked in Fig. 2.193 (h). After handling series parallel combinations for further simplifications.

$$R_{AB} = 36 \text{ ohms.}$$

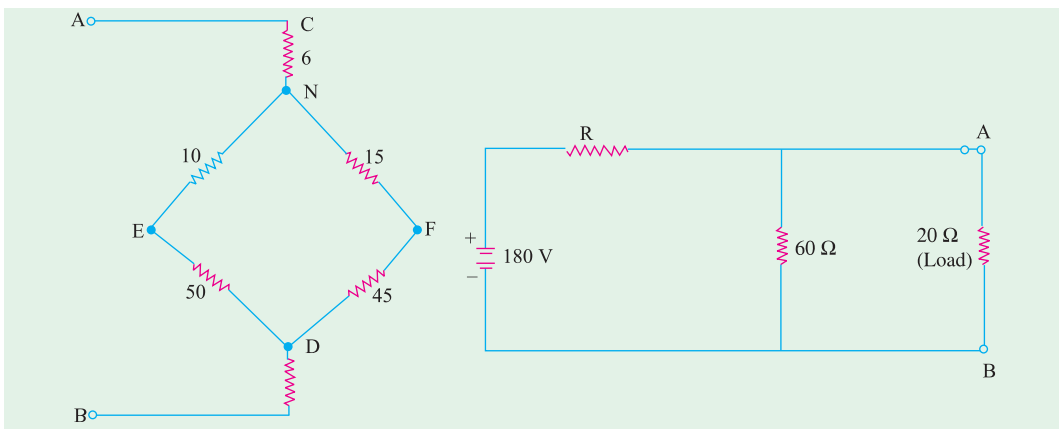

Fig. 2.193 (h)

Fig. 2.193 (i)

Example 2.94 (b). Consider the electric circuit shown in Fig. 2.193 (i)

Determine : (i) the value of R so that load of 20 ohm should draw the maximum power; (ii) the value of the maximum power drawn by the load. [U.P. Technical University, 2001]

Solution. Maximum power transfer takes place when load resistance = Thevenin's Resistance = 20 ohms, here

$$\begin{aligned} R/60 &= 20 \text{ ohms, giving } R = 30 \text{ ohms} \\ V_{TH} &= 180 \times (60/90) = 120 \text{ volts} \\ \text{Current through load} &= 120/40 = 3 \text{ amps} \\ \text{Maximum Power Load} &= 180 \text{ watts} \end{aligned}$$

Tutorial Problems No. 2.6

Delta/Star Conversion

- Find the current in the $17\ \Omega$ resistor in the network shown in Fig. 2.194 (a) by using (a) star/delta conversion and (b) Thevenin's theorem. The numbers indicate the resistance of each member in ohms. [10/3A]
- Convert the star circuit of Fig. 2.194 (b) into its equivalent delta circuit. Values shown are in ohms. Derive the formula used. (Elect. Technology, Indor Univ.)

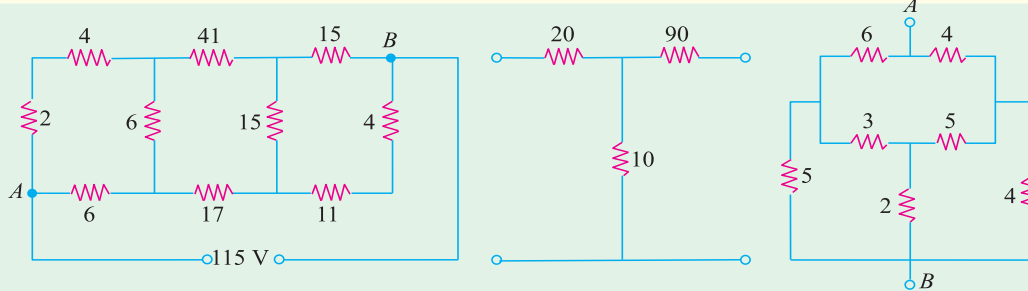

Fig. 2.194 (a)

Fig. 2.194 (b)

Fig. 2.195

- Determine the resistance between points A and B in the network of Fig. 2.195. [4.23 Ω] (Elect. Technology, Indor Univ.)
- Three resistances of $20\ \Omega$ each are connected in star. Find the equivalent delta resistance. If the source of e.m.f. of $120\ \text{V}$ is connected across any two terminals of the equivalent delta-connected resistances, find the current supplied by the source. [60 Ω , 3A] (Elect. Engg. Calcutta Univ.)

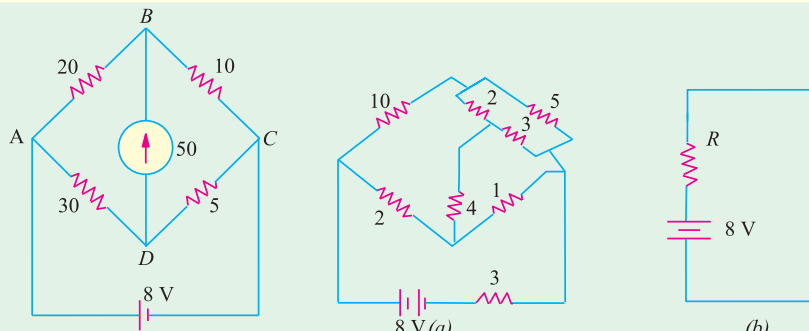

Fig. 2.196

Fig. 2.197

- Using delta/star transformation determine the current through the galvanometer in the Wheatstone bridge of Fig. 2.196. [0.025 A]
- With the aid of the delta star transformation reduce the network given in Fig. 2.197 (a) to the equivalent circuit shown at (b) [R = 5.38 Ω]
- Find the equivalent resistance between points A and B of the circuit shown in Fig. 2.198. [1.4 R]
- By first using a delta-star transformation on the mesh ABCD of the circuit shown in Fig. 2.199, prove that the current supplied by the battery is $90/83\ \text{A}$.

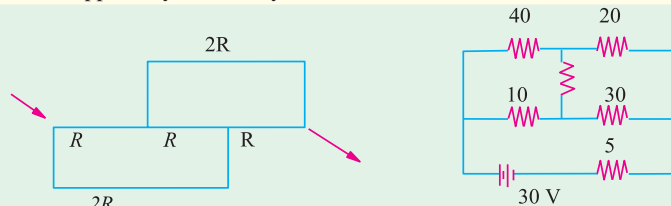

Fig. 2.198

Fig. 2.199

2.24. Compensation Theorem

This theorem is particularly useful for the following two purposes :

- (a) For analysing those networks where the values of the branch elements are varied and for studying the effect of tolerance on such values.
- (b) For calculating the sensitivity of bridge network.
- As applied to d.c. circuits, it may be stated in the following for ways :
- (i) In its simplest form, this theorem asserts that *any resistance R in a branch of a network in which a current I is flowing can be replaced, for the purposes of calculations, by a voltage equal to $-IR$.*

OR

- (ii) *If the resistance of any branch of network is changed from R to $(R + \Delta R)$ where the current flowing originally is I , the change of current at any other place in the network may be calculated by assuming that an e.m.f. $-I \cdot \Delta R$ has been injected into the modified branch while all other sources have their e.m.f.s. suppressed and are represented by their internal resistances only.*

Example 2.95. Calculate the values of new currents in the network illustrated in Fig. 2.200 when the resistor R_3 is increased (in place of s) by 30 %.

Solution. In the given circuit, the values of various branch currents are

$$I_1 = 75/(5 + 10) = 5 \text{ A}$$

$$I_2 = I_3 = 2.5 \text{ A}$$

Now, value of

$$R_3 = 20 + (0.3 \times 20) = 26 \Omega$$

$$\therefore \Delta R = 6 \Omega$$

$$V = -I_3 \Delta R$$

$$= -2.5 \times 6 = -15 \text{ V}$$

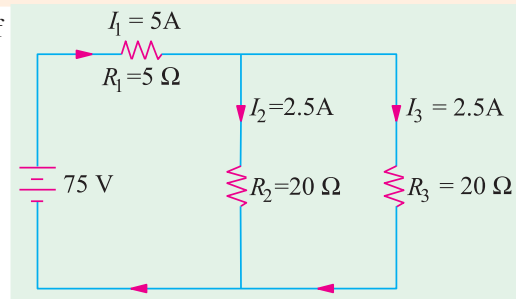

Fig. 2.200

The compensating currents produced by this voltage are as shown in Fig. 2.201 (a).

When these currents are added to the original currents in their respective branches the new current distribution becomes as shown in Fig. 2.201 (b)

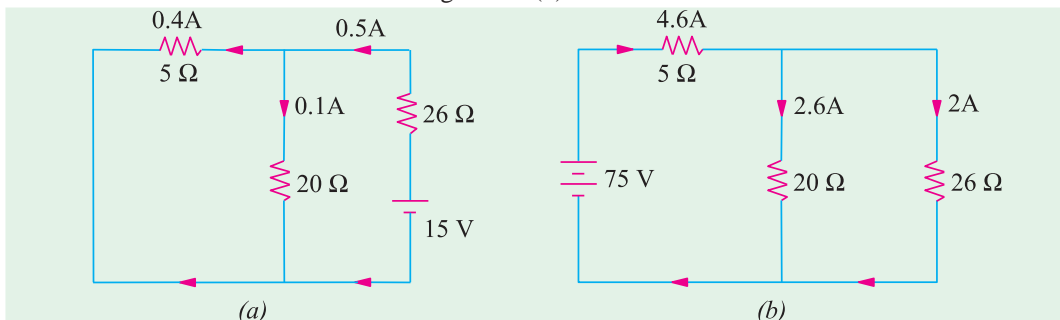

Fig. 2.201

2.25. Norton's Theorem

This theorem is an alternative to the Thevenin's theorem. In fact, it is the dual of Thevenin's theorem. Whereas Thevenin's theorem reduces a two-terminal active network of linear resistances and generators to an equivalent constant-voltage source and series resistance, Norton's theorem replaces the network by an equivalent constant-current source and a parallel resistance.

This theorem may be stated as follows :

(i) *Any two-terminal active network containing voltage sources and resistance when viewed from its output terminals, is equivalent to a constant-current source and a parallel resistance. The constant current is equal to the current which would flow in a short-circuit placed across the terminals and parallel resistance is the resistance of the network when viewed from these open-circuited terminals after all voltage and current sources have been removed and replaced by their internal resistances.*

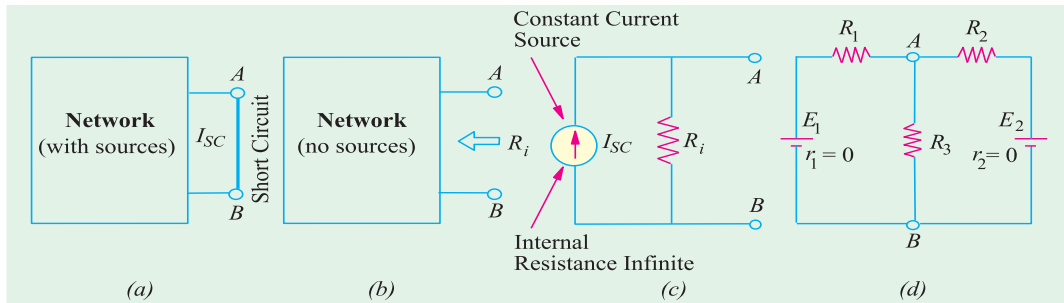

Fig. 2.202

Explanation

As seen from Fig. 2.202 (a), a short is placed across the terminals *A* and *B* of the network **with all its energy sources present**. The short-circuit current I_{SC} gives the value of constant-current source.

For finding R_i , all sources have been removed as shown in Fig. 2.202 (b). The resistance of the network when looked into from terminals *A* and *B* gives R_i .

The Norton's* equivalent circuit is shown in Fig. 2.202 (c). It consists of an ideal constant-current source of infinite internal resistance (Art. 2.16) having a resistance of R_i connected in parallel with it. Solved Examples 2.96, 2.97 and 2.98 etc. illustrate this procedure.

(ii) Another useful generalized form of this theorem is as follows :

The voltage between any two points in a network is equal to $I_{SC} \cdot R_i$ where I_{SC} is the short-circuit current between the two points and R_i is the resistance of the network as viewed from these points with all voltage sources being replaced by their internal resistances (if any) and current sources replaced by open-circuits.

Suppose, it is required to find the voltage across resistance R_3 and hence current through it [Fig. 2.202 (d)]. If short-circuit is placed between *A* and *B*, then current in it due to battery of e.m.f. E_1 is E_1/R_1 and due to the other battery is E_2/R_2 .

$$\therefore I_{SC} = \frac{E_1}{R_1} + \frac{E_2}{R_2} = E_1 G_1 + E_2 G_2$$

where G_1 and G_2 are branch conductances.

Now, the internal resistance of the network as viewed from *A* and *B* simply consists of three resistances R_1 , R_2 and R_3 connected in parallel between *A* and *B*. Please note that here load resistance **R_3 has not been removed**. In the first method given above, it has to be removed.

$$\begin{aligned} \therefore \frac{1}{R_i} &= \frac{1}{R_1} + \frac{1}{R_2} + \frac{1}{R_3} = G_1 + G_2 + G_3 \\ \therefore R_i &= \frac{1}{G_1 + G_2 + G_3} \end{aligned} \quad \therefore V_{AB} = I_{SC} \cdot R_i = \frac{E_1 G_1 + E_2 G_2}{G_1 + G_2 + G_3}$$

Current through R_3 is $I_3 = V_{AB}/R_3$.

Solved example No. 2.96 illustrates this approach.

* After E.L. Norton, formerly an engineer at Bell Telephone Laboratory, U.S.A.

2.26. How To Nortonize a Given Circuit ?

This procedure is based on the first statement of the theorem given above.

1. Remove the resistance (if any) across the two given terminals and put a short-circuit across them.
2. Compute the short-circuit current I_{SC} .
3. Remove all voltage sources but retain their internal resistances, if any. Similarly, remove all current sources and replace them by open-circuits *i.e.* by infinite resistance.
4. Next, find the resistance R_1 (also called R_N) of the network as looked into from the given terminals. It is exactly the same as R_{th} (Art. 2.16).
5. The current source (I_{SC}) joined in parallel across R_i between the two terminals gives Norton's equivalent circuit.

As an example of the above procedure, please refer to Solved Example No. 2.87, 88, 90 and 91 given below.

Example 2.96. Determine the Thevenin and Norton equivalent circuits between terminals A and B for the voltage divider circuit of Fig. 2.203 (a).

Solution. (a) Thevenin Equivalent Circuit

$$\text{Obviously, } V_{th} = \text{drop across } R_2 = E \frac{R_2}{R_1 + R_2}$$

When battery is replaced by a short-circuit.

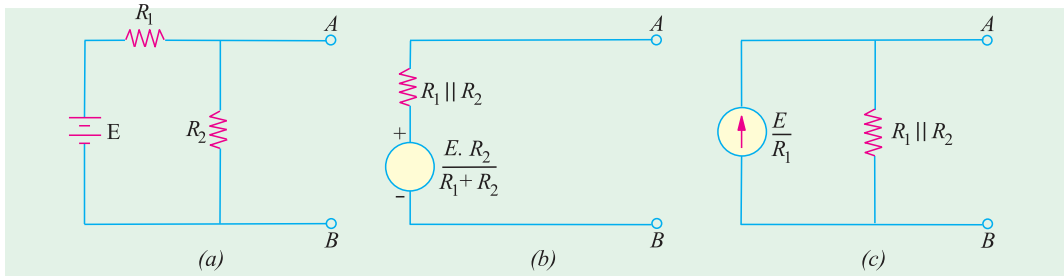

Fig. 2.203

$$R_i = R_1 \parallel R_2 = R_1 R_2 / (R_1 + R_2)$$

Hence, Thevenin equivalent circuit is as shown in Fig. 2.203 (b).

(b) Norton Equivalent Circuit

A short placed across terminals A and B will short out R_2 as well. Hence, $I_{SC} = E/R_1$. The Norton equivalent resistance is exactly the same as Thevenin resistance except that it is connected in parallel with the current source as shown in Fig. 2.203 (c)

Example 2.97. Using Norton's theorem, find the constant-current equivalent of the circuit shown in Fig. 2.204 (a).

Solution. When terminals A and B are short-circuited as shown in Fig. 2.204 (b), total resistance of the circuit, as seen by the battery, consists of a 10Ω resistance in series with a parallel combination of 10Ω and 15Ω resistances.

$$\therefore \text{ total resistance} = 10 + \frac{15 \times 10}{15 + 10} = 16 \Omega$$

$$\therefore \text{ battery current } I = 100/16 = 6.25 \text{ A}$$

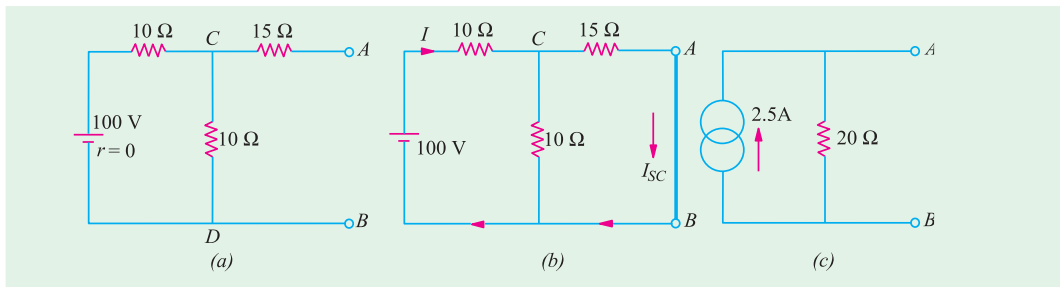

Fig. 2.204

This current is divided into two parts at point C of Fig. 2.204 (b).

Current through A B is $I_{SC} = 6.25 \times 10/25 = 2.5 \text{ A}$

Since the battery has no internal resistance, the input resistance of the network when viewed from A and B consists of a 15 Ω resistance in series with the parallel combination of 10 Ω and 10 Ω
Hence, $R_1 = 15 + (10/2) = 20 \text{ Ω}$

Hence, the equivalent constant-current source is as shown in Fig. 2.204 (c).

Example 2.98. Apply Norton's theorem to calculate current flowing through 5 – Ω resistor of Fig. 2.05 (a).

Solution. (i) Remove 5 – Ω resistor and put a short across terminals A and B as shown in Fig. 2.205 (b). As seen, 10 –Ω resistor also becomes short-circuited.

(ii) Let us now find I_{SC} . The battery sees a parallel combination of 4 Ω and 8 Ω in series with a 4 Ω resistance. Total resistance seen by the battery = $4 + 4 \parallel 8 = 20/3 \text{ Ω}$ Hence, $I = 20 + 20/3 = 3 \text{ A}$. This current divides at point C of Fig. 2.205 (b). Current going along path CAB gives I_{SC} . Its value = $3 \times 4/12 = 1 \text{ A}$.

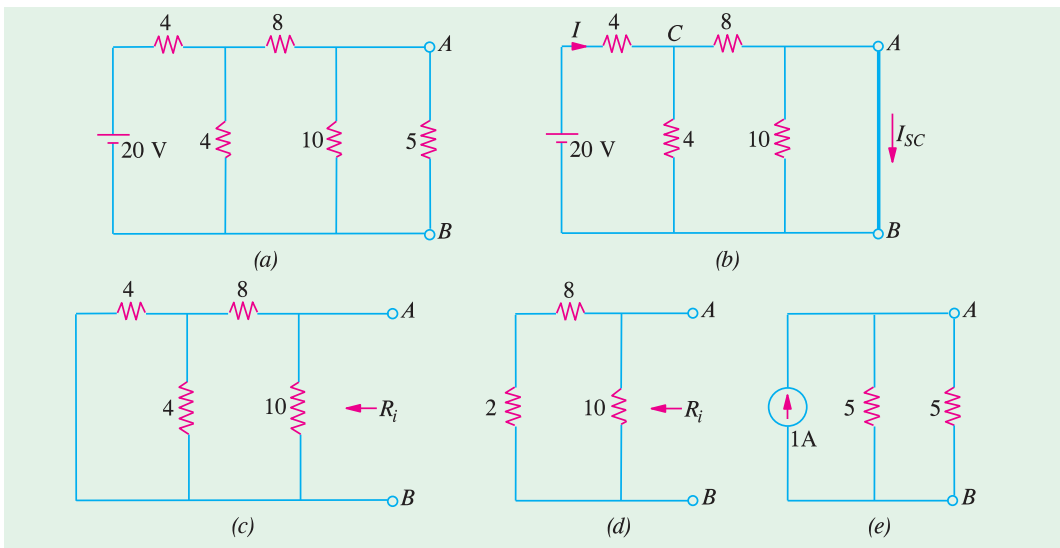

Fig. 2.205

(iii) In Fig. 2.205 (c), battery has been removed leaving behind its internal resistance which, in this case, is zero.

Resistance of the network looking into the terminals A and B in Fig. 2.205 (d) is

$$R_i = 10 \parallel 10 = 5 \text{ Ω}$$

(iv) Hence, Fig. 2.205 (e), gives the Norton's equivalent circuit.

(v) Now, join the $5\text{-}\Omega$ resistance back across terminals A and B . The current flowing through it, obviously, is $I_{AB} = 1 \times 5/10 = \mathbf{0.5\text{ A}}$.

Example 2.99. Find the voltage across points A and B in the network shown in Fig. 2.206 (a) by using Norton's theorem.

Solution. The voltage between points A and B is $V_{AB} = I_{SC} R_i$

where

I_{SC} = short-circuit current between A and B

R_i = Internal resistance of the network as viewed from points A and B .

When short-circuit is placed between A and B , the current flowing in it due to 50-V battery is

$$= 50/50 = 1\text{ A} \quad \text{-- from } A \text{ to } B$$

$$\text{Current due to } 100\text{ V battery is } = 100/20 = 5\text{ A} \quad \text{-- from } B \text{ to } A$$

$$I_{SC} = 1 - 5 = -4\text{ A} \quad \text{-- from } B \text{ to } A$$

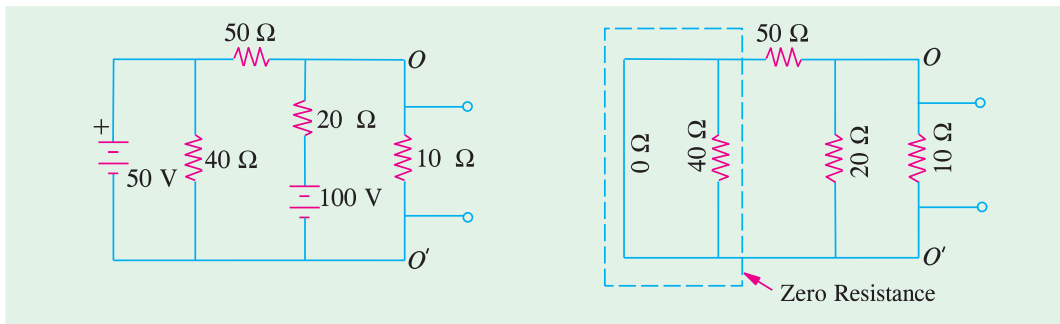

Fig. 2.206 (a)

Fig. 2.206 (b)

Now, suppose that the two batteries are removed so that the circuit becomes as shown in Fig. 2.206 (b). The resistance of the network as viewed from points A and B consists of three resistances of $10\text{ }\Omega$, $20\text{ }\Omega$ and $50\text{ }\Omega$ ohm connected in parallel (as per second statement of Norton's theorem).

$$\therefore \frac{1}{R_i} = \frac{1}{10} + \frac{1}{20} + \frac{1}{50}; \quad \text{hence } R_i = \frac{100}{17}\text{ }\Omega$$

$$\therefore V_{AB} = -4 \times 100/17 = \mathbf{-23.5\text{ V}}$$

The negative sign merely indicates that point B is at a higher potential with respect to the point A .

Example 2.100. Using Norton's theorem, calculate the current flowing through the $15\text{ }\Omega$ load resistor in the circuit of Fig. 2.207 (a). All resistance values are in ohm.

Solution. (a) Short-Circuit Current I_{SC}

As shown in Fig. 2.207 (b), terminals A and B have been shorted after removing $15\text{ }\Omega$ resistor. We will use Superposition theorem to find I_{SC} .

(i) When Only Current Source is Present

In this case, 30-V battery is replaced by a short-circuit. The 4 A current divides at point D between parallel combination of $4\text{ }\Omega$ and $6\text{ }\Omega$. Current through $6\text{ }\Omega$ resistor is

$$I_{sc}' = 4 \times 4/(4 + 6) = 1.6\text{ A} \quad \text{-- from } B \text{ to } A$$

(ii) When Only Battery is Present

In this case, current source is replaced by an open-circuit so that no current flows in the branch CD . The current supplied by the battery constitutes the short-circuit current

$$\therefore I_{sc}'' = 30/(4 + 6) = \mathbf{3\text{ A}} \quad \text{-- from } A \text{ to } B$$

$$\therefore I_{sc} = I_{sc}'' - I_{sc}' = 3 - 1.6 = \mathbf{1.4\text{ A}} \quad \text{-- from } A \text{ to } B$$

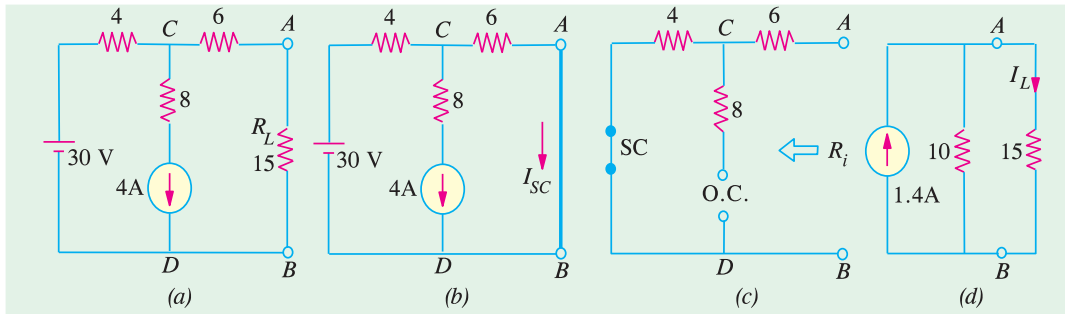

Fig. 2.207

(b) Norton's Parallel Resistance

As seen from Fig. 2.207 (c) $R_1 = 4 + 6 = 10 \Omega$. The 8Ω resistance does not come into the picture because of an open in the branch CD.

Fig. 2.207 (d) shows the Norton's equivalent circuit along with the load resistor.

$$I_L = 1.4 \times 10 / (10 + 15) = 0.56 \text{ A}$$

Example 2.101. Using Norton's current-source equivalent circuit of the network shown in Fig. 2.208 (a), find the current that would flow through the resistor R_2 when it takes the values of 12, 24 and 36 Ω respectively. [Elect. Circuits, South Gujarat Univ.]

Solution. In Fig. 2.208 (b), terminals A and B have been short-circuited. Current in the shorted path due to E_1 is $= 120/40 = 3 \text{ A}$ from A to B. Current due to E_2 is $180/60 = 3 \text{ A}$ from A to B. Hence $I_{SC} = 6 \text{ A}$. With batteries removed, the resistance of the network when viewed from open-circuited terminals is $40 \parallel 60 = 24 \Omega$

- (i) When $R_L = 12 \Omega$ $I_L = 6 \times 24 / (24 + 12) = 4 \text{ A}$
- (ii) When $R_L = 24 \Omega$ $I_L = 6/2 = 3 \text{ A}$.
- (iii) When $R_L = 36 \Omega$ $I_L = 6 \times 24 / (24 + 36) = 2.4 \text{ A}$.

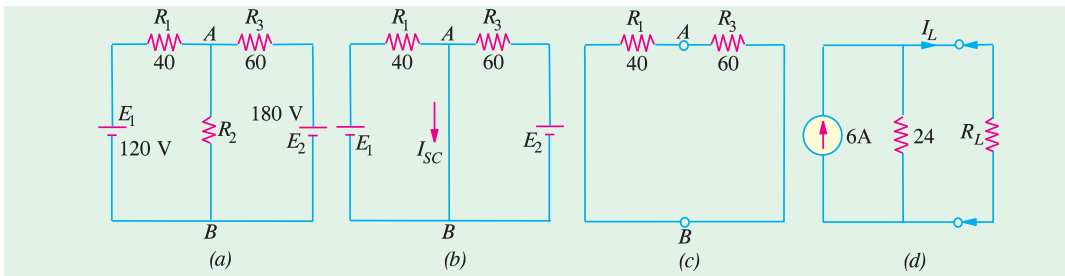
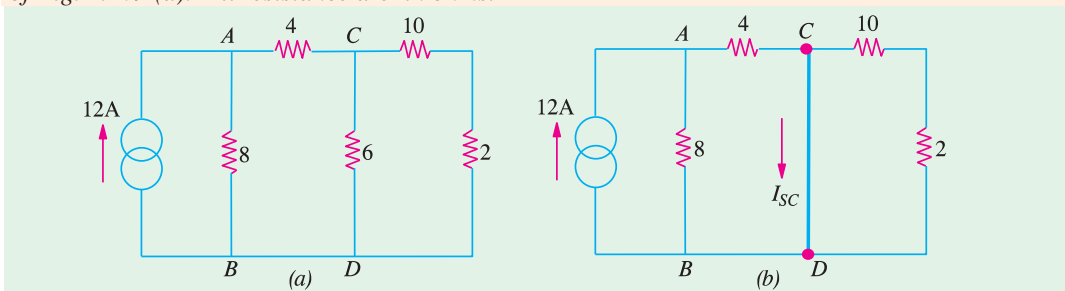

Fig. 2.208

Example 2.102. Using Norton's theorem, calculate the current in the 6- Ω resistor in the network of Fig. 2.209 (a). All resistance are in ohms.



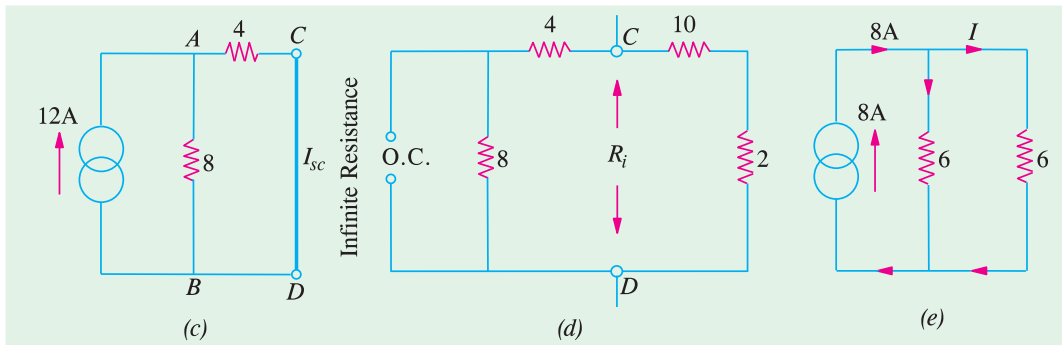

Fig. 2.209

Solution. When the branch containing $6\text{-}\Omega$ resistance is short-circuited, the given circuit is reduced to that shown in Fig. 2.209 (b) and finally to Fig. 2.209 (c). As seen, the 12 A current divides into two unequal parts at point A. The current passing through $4\text{ }\Omega$ resistor forms the short-circuit current I_{SC} .

Resistance R_i between points C and D when they are open-circuited is

$$R_i = \frac{(4\ 8)}{(4\ 8)} \frac{(10\ 2)}{(10\ 2)} \ 6$$

It is so because the constant-current source has *infinite* resistance *i.e.*, it behaves like an open circuit as shown in Fig. 2.209 (d).

Hence, Norton's equivalent circuit is as shown in Fig. 2.209 (e). As seen current of 8 A is divided equally between the two equal resistances of $6\text{ }\Omega$ each. Hence, current through the required $6\text{ }\Omega$ resistor is 4 A .

$$I_{SC} = 12 \times \frac{8}{8+4} = 8\text{ A}$$

Example 2.103. Using Norton's theorem, find the current which would flow in a $25\text{-}\Omega$ resistor connected between points N and O in Fig. 2.210 (a). All resistance values are in ohms.

Solution. For case of understanding, the given circuit may be redrawn as shown in Fig. 2.210 (b). Total current in short-circuit across ON is equal to the sum of currents driven by different batteries through their respective resistances.

$$I_{SC} = \frac{10}{5} + \frac{20}{10} + \frac{30}{20} = 5.5\text{ A}$$

The resistance R_i of the circuit when looked into from point N and O is

$$\frac{1}{R_i} = \frac{1}{5} + \frac{1}{10} + \frac{1}{20} = \frac{7}{20}\ \Omega; \ R_i = \frac{20}{7}\ \Omega = 2.86\ \Omega$$

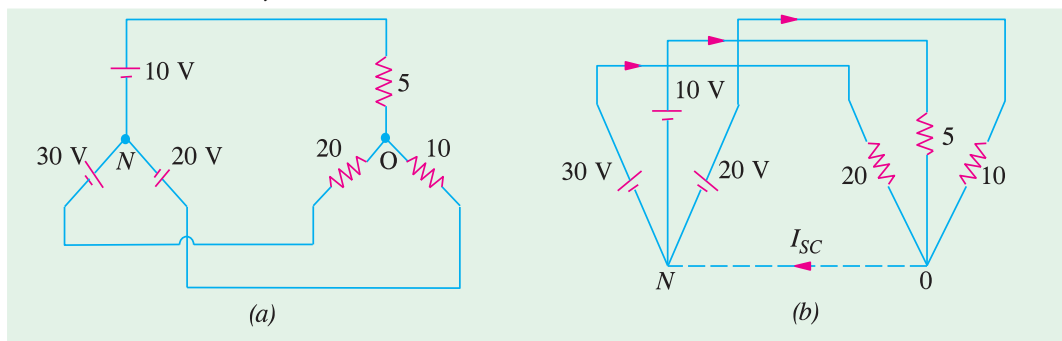

Fig. 2.210

Hence, given circuit reduces to that shown in Fig. 2.211 (a).

Open-circuit voltage across NO is $= I_{SC}R_i$
 $= 5.5 \times 2.86 = 15.73 \text{ V}$

Hence, current through $25\text{-}\Omega$ resistor connected across NO is [Fig. 2.211 (b)]

$$I = 15.73/25 = 0.63 \text{ A}$$

$$\text{or } I = 5.5 \frac{2.86}{2.86 + 25} = 0.56 \text{ A.}$$

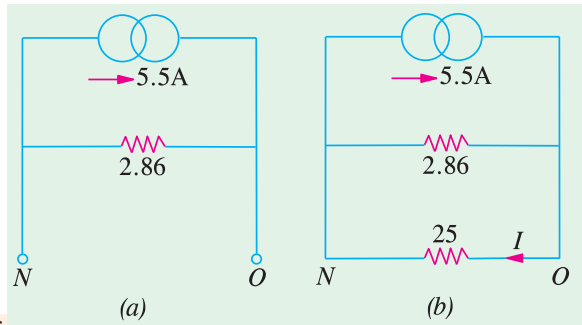

Fig. 2.211

Example 2.104. With the help of Norton's theorem, find V_o in the circuit shown in Fig. 2.212 (a). All resistances are in ohms.

Solution. For solving this circuit, we will Nortonise the circuit to the left to the terminals $1-1'$ and to the right of terminals $2-2'$, as shown in Fig. 2.212 (b) and (c) respectively.

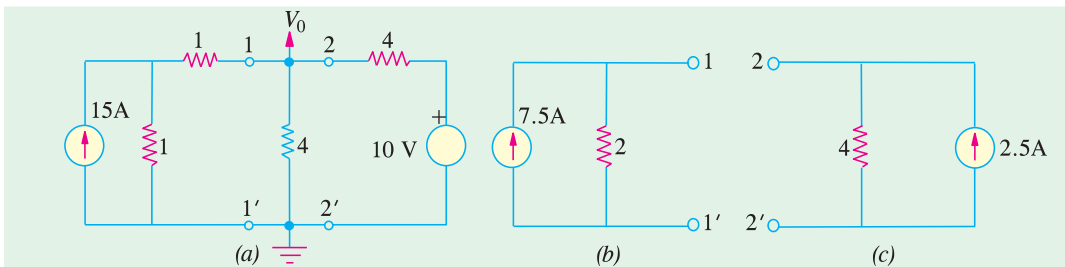

Fig. 2.212

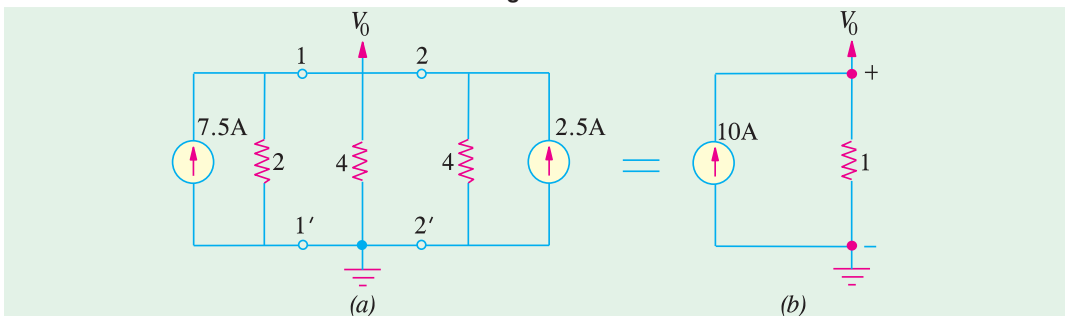

Fig. 2.213

The two equivalent Norton circuits can now be put back across terminals $1-1'$ and $2-2'$, as shown in Fig. 2.213 (a).

The two current sources, being in parallel, can be combined into a single source of $7.5 + 2.5 = 10 \text{ A}$. The three resistors are in parallel and their equivalent resistance is $2 \parallel 4 \parallel 4 = 1 \text{ }\Omega$. The value of V_o as seen from Fig. 2.213 (b) is $V_o = 10 \times 1 = 10 \text{ V}$.

Example 2.105. For the circuit shown in Fig. 2.214 (a), calculate the current in the $6 \text{ }\Omega$ resistance by using Norton's theorem. (Elect. Tech. Osmania Univ. Feb. 1992)

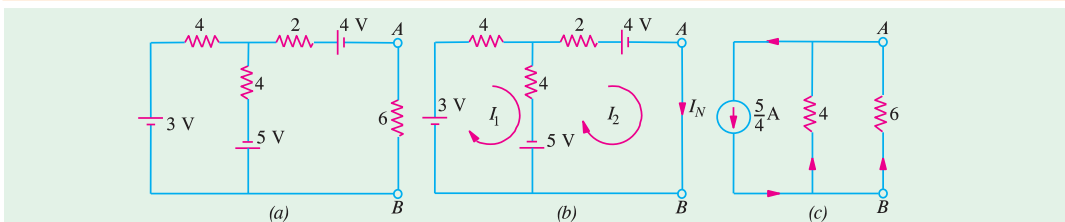

Fig. 2.214

Solution. As explained in Art. 2.19, we will replace the $6\ \Omega$ resistance by a short-circuit as shown in Fig. 2.214 (b). Now, we have to find the current passing through the short-circuited terminals A and B . For this purpose we will use the mesh analysis by assuming mesh currents I_1 and I_2 .

From mesh (i), we get

$$3 - 4I_1 - 4(I_1 - I_2) + 5 = 0 \quad \text{or} \quad 2I_1 - I_2 = 2 \quad \dots(i)$$

From mesh (ii), we get

$$-2I_2 - 4 - 5 - 4(I_2 - I_1) = 0 \quad \text{or} \quad 4I_1 - 6I_2 = 9 \quad \dots(ii)$$

From (i) and (ii) above, we get $I_2 = -5/4$

The negative sign shows that the actual direction of flow of I_2 is opposite to that shown in Fig. 2.214 (b). Hence, $I_{sh} = I_N = I_2 = -5/4\ \text{A}$ i.e. current flows from point B to A .

After the terminals A and B are open-circuited and the three batteries are replaced by short-circuits (since their internal resistances are zero), the internal resistance of the circuit, as viewed from these terminals' is

$$R_i = R_N = 2 + 4 \parallel 4 = 4\ \Omega$$

The Norton's equivalent circuit consists of a constant current source of $5/4\ \text{A}$ in parallel with a resistance of $4\ \Omega$ as shown in Fig. 2.214 (c). When $6\ \Omega$ resistance is connected across the equivalent circuit, current through it can be found by the current-divider rule (Art).

$$\text{Current through } 6\ \Omega \text{ resistor} = \frac{5}{4} \times \frac{4}{10} = 0.5 \text{ from } B \text{ to } A.$$

2.27. General instructions For Finding Norton Equivalent Circuit

Procedure for finding Norton equivalent circuit of a given network has already been given in Art. That procedure applies to circuits which contain resistors and independent voltage or current sources. Similar procedures for circuits which contain both dependent and independent sources or only dependent sources are given below :

(a) Circuits Containing Both Dependent and Independent Sources

- (i) Find the open-circuit voltage v_{oc} with all the sources activated or 'alive'.
- (ii) Find short-circuit current i_{sh} by short-circuiting the terminals a and b but with all sources activated.
- (iii) $R_N = V_{oc}/i_{sh}$

(b) Circuits Containing Dependent Sources Only

- (i) $i_{sh} = 0$.
- (ii) Connect 1 A source to the terminals a and b calculate v_{ab} .
- (iii) $R_N = v_{ab}/1$.

Example 2.106. Find the Norton equivalent for the transistor amplifier circuit shown in Fig. 2.215 (a). All resistances are in ohms.

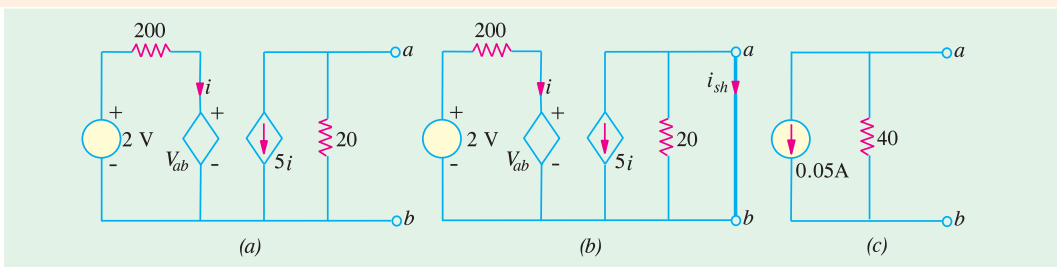

Fig. 2.215

Solution. We have to find the values of i_{sh} and R_N . It should be noted that when terminals a and b are short-circuited, $v_{ab} = 0$. Hence, in that case, we find from the left-hand portion of the circuit that $i = 2/200 = 1/100\text{A} = 0.01\text{A}$. As seen from Fig. 2.215 (b), the short-circuit across terminals a and b , short circuits $20\ \Omega$ resistance also. Hence, $i_{sh} = -5i = -5 \times 0.01 = -0.05\text{A}$.

Now, for finding R_N , we need $v_{oc} = v_{ab}$ from the left-hand portion of the Fig. 2.215 (a). Applying KVL to the closed circuit, we have

$$2 - 200i - v_{ab} = 0 \quad \dots(i)$$

Now, from the right-hand portion of the circuit, we find $v_{ab} = \text{drop over } 20\ \Omega \text{ resistance} = -20 \times 5i = -100i$. The negative sign is explained by the fact that current flows from point b towards point a . Hence, $i = -v_b/100$. Substituting this value in Eqn. (i) above, we get

$$2 - 200(-v_b/100) - v_{ab} = 0 \quad \text{or} \quad v_{ab} = -2\text{V}$$

$$\therefore R_N = v_{ab}/i_{sh} = -2/-0.05 = 40\ \Omega$$

Hence, the Norton equivalent circuit is as shown in Fig. 2.215 (c).

Example 2.107. Using Norton's theorem, compute current through the $1\text{-}\Omega$ resistor of Fig. 2.216.

Solution. We will employ source conversion technique to simplify the given circuit. To begin with, we will convert the three voltage sources into their equivalent current sources as shown in Fig. 2.216 (b) and (c). We can combine together the two current sources on the left of EF but cannot combine the 2-A source across CD because of the $3\text{-}\Omega$ resistance between C and E .

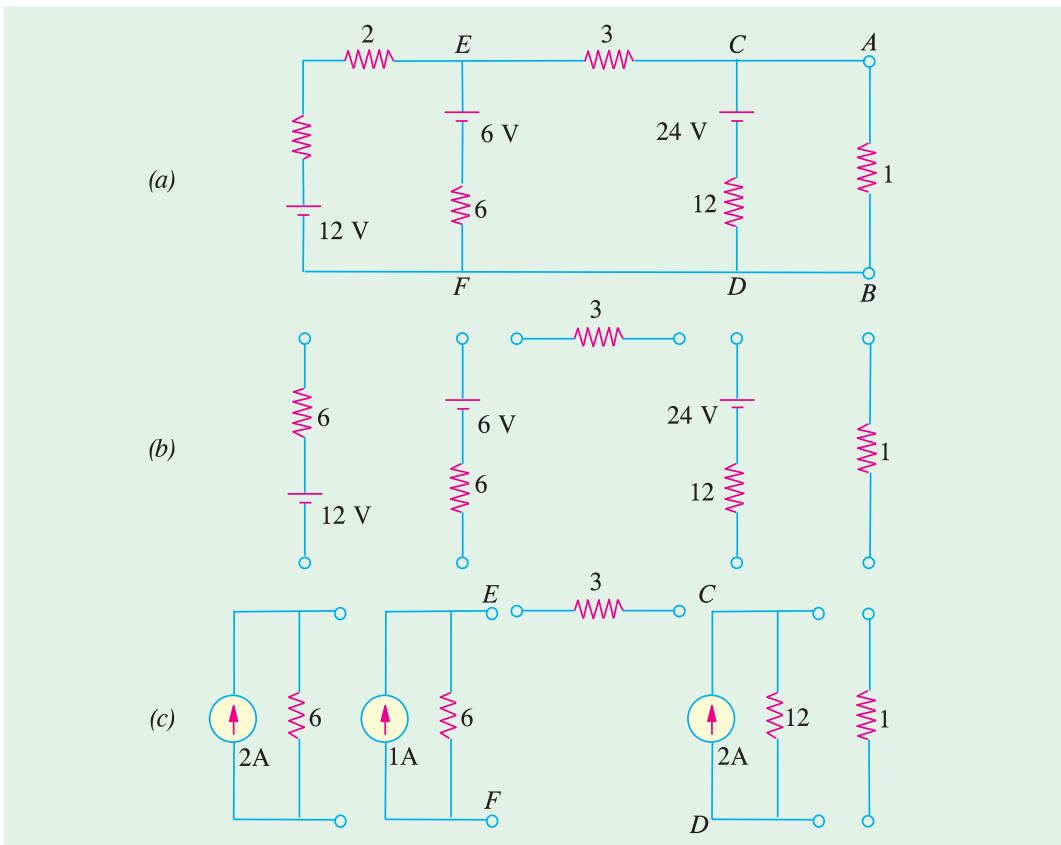

Fig. 2.216

In Fig. 2.217 (b), the two current sources at the left-hand side of $3\ \Omega$ resistor have been replaced by a single $(2\text{A} + 1\text{A}) = 3\text{A}$ current source having a single parallel resistance $6\ \parallel\ 6 = 3\ \Omega$

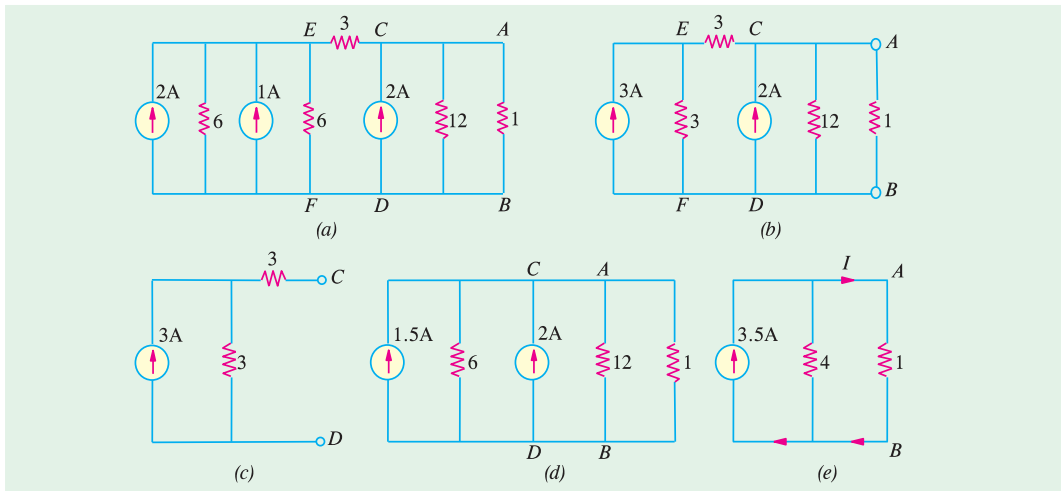

Fig. 2.217

We will now apply Norton's theorem to the circuit on the left-hand side of CD [Fig. 2.217 (c)] to convert it into a single current source with a single parallel resistor to replace the two $3\ \Omega$ resistors. As shown in Fig. 2.217 (d), it yields a $1.5\ \text{A}$ current source in parallel with a $6\ \Omega$ resistor. This current source can now be combined with the one across CD as shown in Fig. 2.217 (e). The current through the $1\text{-}\Omega$ resistor is

$$I = 3.5 \times 4 / (4 + 1) = 2.8\ \text{A}$$

Example 2.108. Obtain Thevenin's and Norton's equivalent circuits at AB shown in Fig. 2.218 (a). [Elect. Network, Analysis Nagpur Univ. 1993]

Solution. Thevenin's Equivalent Circuit

We will find the value of V_{th} by using two methods (i) KVL and (ii) mesh analysis.

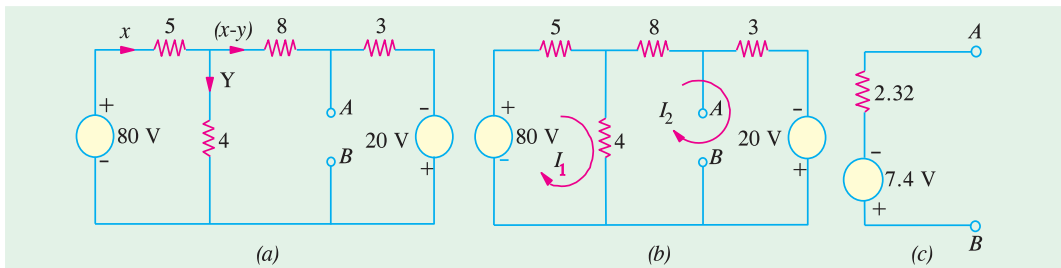

Fig. 2.218

(a) Using KVL

If we apply KVL to the first loop of Fig. 2.218 (a), we get

$$80 - 5x - 4y = 0 \quad \text{or} \quad 5x + 4y = 80 \quad \dots(i)$$

From the second @ loop, we have

$$-11(x - y) + 20 + 4y = 0 \quad \text{or} \quad 11x - 15y = 20 \quad \dots(ii)$$

From (i) and (ii), we get $x = 10.75\ \text{A}$; $y = 6.56\ \text{A}$ and $(x - y) = 4.2\ \text{A}$.

Now, $V_{th} = V_{AB}$ i.e. voltage of point A with respect to point B. For finding its value, we start from point B and go to point A either via $3\ \Omega$ resistance or $4\ \Omega$ resistance or $(5 + 8) = 13\ \Omega$ resistance and take the algebraic sum of the voltage met on the way. Taking the first route, we get

$$V_{AB} = -20 + 3(x - y) = -20 + 3 \times 4.2 = -7.4\ \text{V}$$

It shows that point A is negative with respect to point B or, which is the same thing, point B is positive with respect to point A.

(b) Mesh Analysis [Fig. 2.218 (b)]

Here, $R_{11} = 9$; $R_{22} = 15$; $R_{21} = -4$

$$\therefore \begin{vmatrix} 9 & -4 \\ -4 & 15 \end{vmatrix} \begin{vmatrix} I_1 \\ I_2 \end{vmatrix} = \begin{vmatrix} 80 \\ 20 \end{vmatrix}; \Delta = 135 - 16 = 119$$

$$\Delta_1 = \begin{vmatrix} 80 & -4 \\ 20 & 15 \end{vmatrix} = 1280; \Delta_2 = \begin{vmatrix} 9 & 80 \\ -4 & 20 \end{vmatrix} = 500$$

$$I_1 = 1280/119 = 10.75 \text{ A}; I_2 = 500/119 = 4.2 \text{ A}$$

Again $V_{AB} = -20 + 12.6 = -7.4 \text{ V}$

Value of R_{th}

For finding R_{th} , we replace the two voltage sources by short-circuits.

$$\therefore R_{th} = R_{AB} = 3 \parallel (8 + 4 \parallel 5) = 2.32 \Omega$$

The Thevenin's equivalent circuit becomes as shown in Fig. 2.219 (c). It should be noted that point B has been kept positive with respect to point A in the Fig.

Example 2.109. Find current in the 4 ohm resistor by any three methods.

[Bombay University 2000]

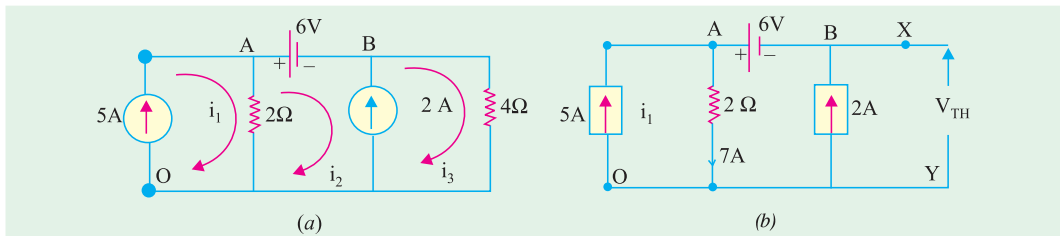

Fig. 2.219

Solution. Method 1 : Writing down circuit equations, with given conditions, and marking three clockwise loop-currents as i_1 , i_2 and i_3 .

$$\begin{aligned} \mathbf{i_1} &= 5 \text{ A, due to the current source of 5 Amp} \\ V_A - V_B &= 6 \text{ V, due to the voltage source of 6 Volts} \\ \mathbf{i_3 - i_2} &= 2 \text{ A, due to the current source of 2 Amp.} \\ V_A &= (\mathbf{i_1 - i_2}) 2, \quad V_B = \mathbf{i_3} \times 4 \end{aligned}$$

With these equations, the unknowns can be evaluated.

$$2(i_1 - i_2) - 4i_3 = 6, \quad 2(5 - i_2) - 4(2 + i_2) = 6$$

This gives the following values : $i_2 = -2/3 \text{ Amp.}$, $i_3 = 4/3 \text{ Amp.}$

$$V_A = 34/3 \text{ volts, } V_B = 16/3 \text{ volts}$$

Method 2 : Thevenin's theorem : Redraw the circuit with modifications as in Fig. 2.219 (b)

$$R_{TH} = +14 - 6 = 8 \text{ V}$$

$R_{TH} = 2 \text{ ohms}$, looking into the circuit form X - Y terminals after de-activating the sources

$$I_L = 8/(2 + 4) = 4/3 \text{ Amp.}$$

Method 3 : Norton's Theorem : Redraw modifying as in Fig. 2.219 (c)

$$I_N = 2 + 2 = 4 \text{ Amp.}$$

This is because, X and Y are at ground potential, 2-ohm resistor has to carry 3 A and hence from 5-Amp. source, 2-Amp current is driven into X - Y nodes.

$$R_N = 2 \text{ ohms}$$

Then the required current is calculated as shown in Fig. 2.219 (d)

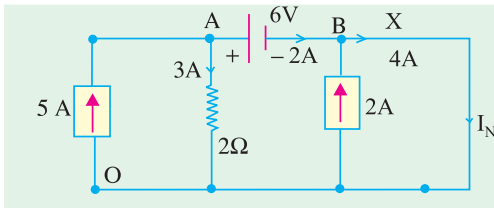

Fig. 2.219 (c) Evaluation of I_N

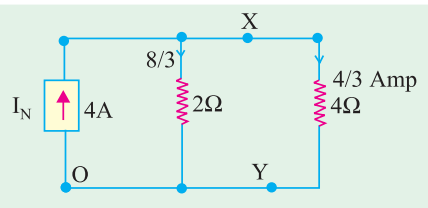

Fig. 2.219 (d)

Note : One more method is described. This transforms the sources such that the current through 4-ohm resistor is evaluated, as in final stage shown in Fig. 2.219 (j) or in Fig. 2.219 (k).

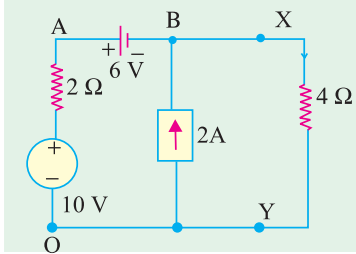

Fig. 2.219 (e)

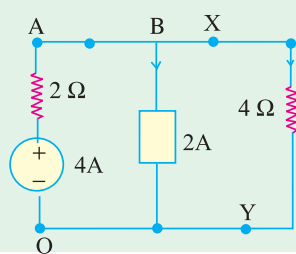

Fig. 2.219 (f)

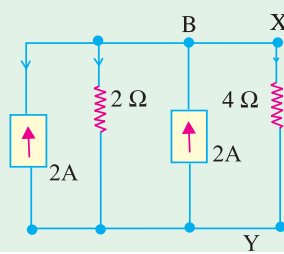

Fig. 2.219 (h)

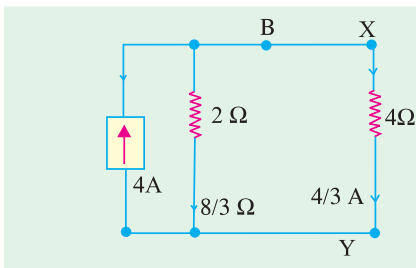

Fig. 2.219 (j)

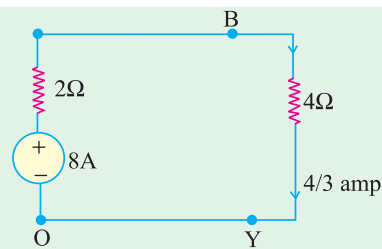

Fig. 2.219 (k)

Example 2.109. (a). Find Mesh currents i_1 and i_2 in the electric circuit of Fig. 2.219 (m)

[U.P. Tech. University, 2001]

Solution. Mark the nodes as shown in Fig. 2.219 (m).

Treat O as the reference node.

From the dependent current source of $3i_1$ amp between B and O ,

$$i_2 - i_1 = 3i_1 \quad \text{or} \quad 4i_1 = i_2 \quad \dots(a)$$

V_B is related to V_A , V_C and the voltage across resistors concerned

$$V_B = V_A - i_1 \times 1 = 4 - i_1$$

$$V_B = V_C + i_2 \times 2 = 3 + 2i_2$$

Hence $4 - i_1 = 3 + 2i_2 \quad \dots(b)$

From equations (a) and (b) above, $i_1 = 1/9$ amp and $i_2 = 4/9$ amp

Substituting these, $V_B = 35/9$ volts

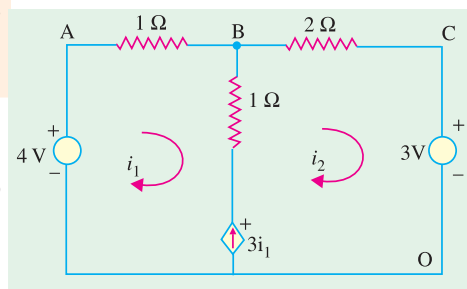

Fig. 2.219 (m)

Example 2.109 (b). Determine current through 6 ohm resistance connected across A-B terminals in the electric circuit of Fig. 2.219 (n), using Thevenin's Theorem. [U.P. Tech. Univ. 2001]

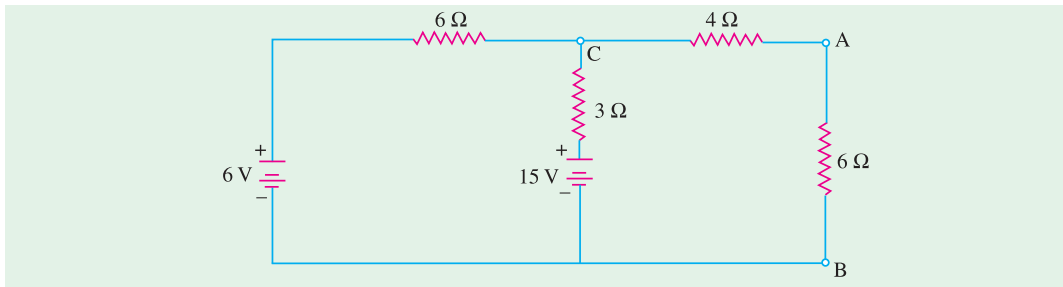

Fig. 2.219 (n)

Solution. Applying Thevenin's theorem, after detaching the 6-ohm resistor from terminals $A - B$,

$$V_{TH} = V_C = 15 - 1 \times 3 = 12 \text{ volts}$$

$$R_{TH} = 4 + 3/6 = 6 \text{ ohms}$$

$$I_L = 12/(6 + 6) = \text{lamp}$$

Example 2.109 (c). Applying Kirchoff's Current Law, determine current I_s in the electric circuit of Fig. 2.219 (p). Take $V_o = 16 \text{ V}$. [U.P. Tech. Univ. 2001]

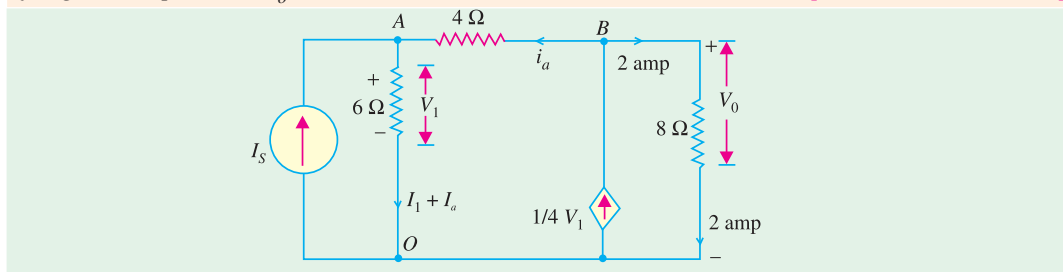

Fig. 2.219 (p)

Solution. Mark the nodes A , B , and O and the currents associated with different branches, as in Fig. 2.219 (p).

Since $V_o = 16 \text{ V}$, the current through 8-ohm resistor is 2 amp.

$$\text{KCL at node B : } 1/4 V_1 = 2 + i_a \quad \dots(a)$$

$$\text{KCL at node A : } I_s + i_a = V_1/6 \quad \dots(b)$$

$$\text{Further, } V_A = V_1, V_B = 16, V_B - V_1 = 4i_a \quad \dots(c)$$

From (a) and (c), $i_a = 1 \text{ amp}$. This gives $V_1 - V_A = 12 \text{ volts}$, and $I_s = 1 \text{ amp}$

The magnitude of the dependent current source = 3 amp

Check : Power from 1 amp current source = $1 \times 12 = 12 \text{ W}$

Power from dependent C.S. of 3 A = $3 \times 16 = 48 \text{ W}$

Sum of source-output-power = 60 watts

Sum of power consumed by resistors = $2^2 \times 6 + 1^2 \times 4 + 2^2 \times 8 = 60 \text{ watts}$

The power from sources equal the consumed by resistors. This confirms that the answers obtained are correct.

Norton's Equivalent Circuit

For this purpose, we will short-circuit the terminals A and B find the short-circuit currents produced by the two voltage sources. When viewed from the side of the 80-V source, a short across AB short-circuits everything on the right side of AB . Hence, the circuit becomes as shown in Fig. 2.230 (a). The short-circuit current I_1 can be found with the help of series-parallel circuit technique. The total resistance offered to the 80-V source is $5 + 4 \parallel 8 = 23/3 \Omega$

$$\therefore I = 80 \times 3/23 = 10.43 \text{ A}; \quad \therefore I_1 = 10.43 \times 4/12 = 3.48 \text{ A}.$$

When viewed from the side of the 20-V source, a short across AB short-circuits everything beyond AB . In the case, the circuit becomes as shown in Fig. 2.230 (b). The short circuit current flowing from B to $A = 20/3 = 6.67 \text{ A}$.

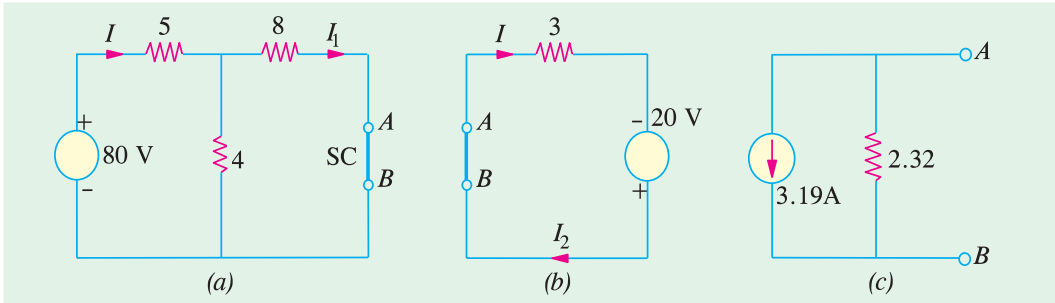

Fig. 2.220

$$\text{Total short-circuit current} = 6.67 - 3.48 = 3.19 \text{ A} \quad \dots \text{ from } B \text{ to } A.$$

$$R_N = R_{th} = 3 \parallel (8 + 4 \parallel 5) = 2.32 \Omega$$

Hence, the Norton's equivalent circuit becomes as shown in Fig. 2.220 (c).

2.28. Millman's Theorem

This theorem can be stated either in terms of voltage sources or current sources or both.

(a) As Applicable to Voltage Sources

This Theorem is a combination of Thevenin's and Norton's theorems. It is used for finding the common voltage across any network which contains a number of parallel voltage sources as shown in Fig. 2.221 (a). Then common voltage V_{AB} which appears across the output terminals A and B is affected by the voltage sources E_1 , E_2 and E_3 . The value of the voltage is given by

$$V_{AB} = \frac{E_1/R_1 + E_2/R_2 + E_3/R_3}{1/R_1 + 1/R_2 + 1/R_3} = \frac{I_1 + I_2 + I_3}{G_1 + G_2 + G_3} = \frac{\Sigma I}{\Sigma G}$$

This voltage represents the Thevenin's voltage V_{th} . The resistance R_{th} can be found, as usual, by replacing each voltage source by a short circuit. If there is a load resistance R_L across the terminals A and B , then load current I_L is given by

$$I_L = V_{th}/(R_{th} + R_L)$$

If as shown in Fig. 2.222 (b), a branch does not contain any voltage source, the same procedure is used except that the value of the voltage for that branch is equated to zero as illustrated in Example 2.210.

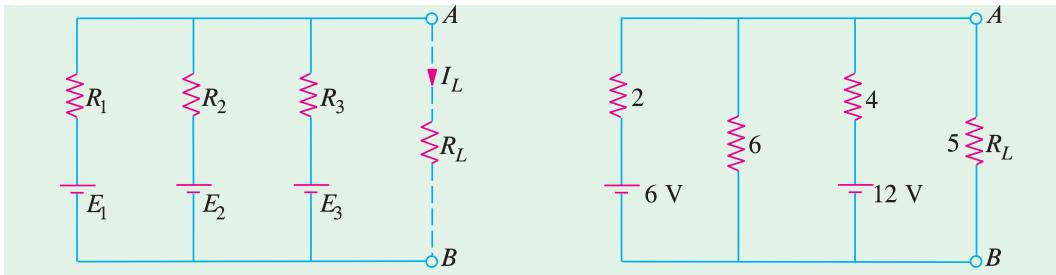

Fig. 2.221

Fig. 2.222

Example 2.110. Use Millman's theorem, to find the common voltage across terminals A and B and the load current in the circuit of Fig. 2.222.

Solution. As per Millman's Theorem,

$$V_{AB} = \frac{6/2 + 0/6 + 12/4}{1/2 + 1/6 + 1/4} = \frac{6}{11/12} = 6.55 \text{ V}$$

\therefore

$$V_{th} = 6.55 \text{ V}$$

$$R_{th} = 2 \parallel 6 \parallel 4 = 12/11 \ \Omega$$

$$I_L = \frac{V_{th}}{R_{th} + R_L} = \frac{6.55}{(12/11) + 5} = 1.05 \text{ A}$$

(b) As Applicable to Current Sources

This theorem is applicable to a mixture of parallel voltage and current sources that are reduced to a single final equivalent source which is either a constant current or a constant voltage source. This theorem can be stated as follows :

Any number of constant current sources which are directly connected in parallel can be converted into a single current source whose current is the algebraic sum of the individual source currents and whose total internal resistances equals the combined individual source resistances in parallel.

Example 2.111. Use Millman's theorem, to find the voltage across and current through the load resistor R_L in the circuit of Fig. 2.223 (a).

Solution. First thing to do is to convert the given voltage sources into equivalent current sources. It should be kept in mind that the two batteries are connected in opposite direction. Using source conversion technique given in Art. 1.14 we get the circuit of Fig. 2.223 (b).

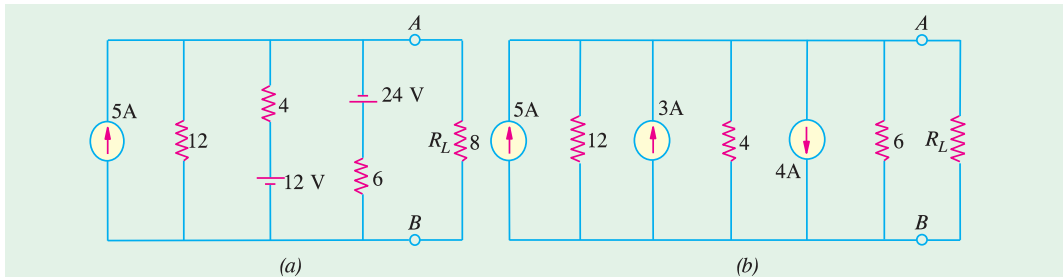

Fig. 2.223

The algebraic sum of the currents = $5 + 3 - 4 = 4 \text{ A}$. The combined resistance is $= 12 \parallel 4 \parallel 6 = 2 \ \Omega$. The simplified circuit is shown in the current-source form in Fig. 2.224 (a) or voltage source form in Fig. 2.224 (b).

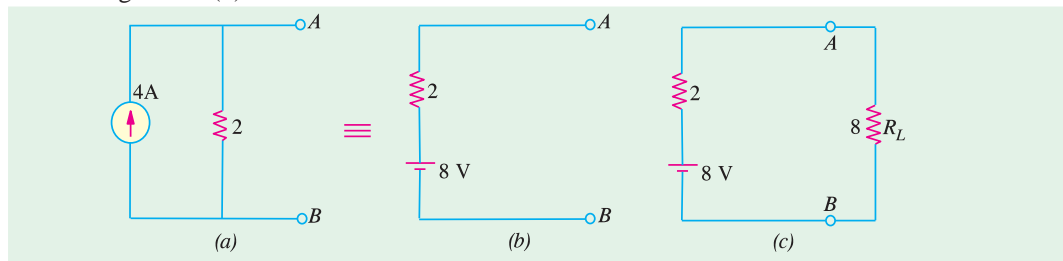

Fig. 2.224

As seen from Fig. 2.224 (c).

$$I_L = 8/(2 + 8) = 0.8 \text{ A} ; V_L = 8 \times 0.8 = 6.4 \text{ V}$$

Alternatively,

$$V_L = 8 \times 8/(2 + 8) = 6.4 \text{ V}$$

Following steps are necessary when using Millman's Theorem :

1. convert all voltage sources into their equivalent current sources.
2. calculate the algebraic sum of the individual dual source currents.

- if found necessary, convert the final current source into its equivalent voltage source.

As pointed out earlier, this theorem can also be applied to voltage sources which must be initially converted into their constant current equivalents.

2.29. Generalised Form of Millman's Theorem

This theorem is particularly useful for solving many circuits which are frequently encountered in both electronics and power applications.

Consider a number of admittances $G_1, G_2, G_3 \dots G_n$ which terminate at common point $0'$ (Fig. 2.225). The other ends of the admittances are numbered as 1, 2, 3... n . Let O be any other point in the network. It should be clearly understood that it is not necessary to know anything about the inter-connection between point O and the end points 1, 2, 3... n . However, what is essential to know is the voltage drops from O to 1, O to 2, ... O to n etc.

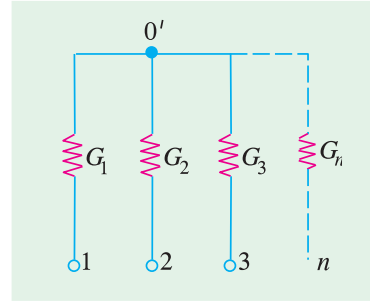

Fig. 2.225

According to this theorem, the voltage drop from O to $0'$ ($V_{00'}$) is given by

$$V_{00'} = \frac{V_{01}G_1 + V_{02}G_2 + V_{03}G_3 + \dots + V_{0n}G_n}{G_1 + G_2 + G_3 + \dots + G_n}$$

Proof

Voltage drop across	$G_1 = V_{10}' = (V_{00}' - V_{01})$
Current through	$G_1 = I_{10}' = V_{10}' G_1 = (V_{00}' - V_{01}) G_1$
Similarly,	$I_{20}' = (V_{00}' - V_{02}) G_2$
	$I_{30}' = (V_{00}' - V_{03}) G_3$

	$I_{n0}' = (V_{00}' - V_{0n}) G_n$

and

By applying KCL to point $0'$, we get

$$I_{10}' + I_{20}' + \dots + I_{n0}' = 0$$

Substituting the values of these currents, we get

$$V_{00'} = \frac{V_{01}G_1 + V_{02}G_2 + V_{03}G_3 + \dots + V_{0n}G_n}{G_1 + G_2 + G_3 + \dots + G_n}$$

Precaution

It is worth repeating that only those resistances or admittances are taken into consideration which terminate at the common point. All those admittances are ignored which do not terminate at the common point even though they are connected in the circuit.

Example 2.112. Use Millman's theorem to calculate the voltage developed across the 40 Ω resistor in the network of Fig. 2.226.

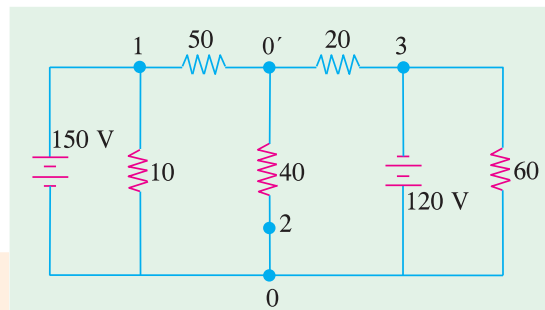

Fig. 2.226

Solution. Let the two ends of the $40\ \Omega$ resistor be marked as 0 and $0'$. The end points of the three resistors terminating at the common point $0'$ have been marked 1, 2 and 3. As already explained in Art. 2.29, the two resistors of values $10\ \Omega$ and $60\ \Omega$ will not come into the picture because they are not directly connected to the common point $0'$.

Here,

$$V_{01} = -150\ \text{V}; \quad V_{02} = 0; \quad V_{03} = 120\ \text{V}$$

$$G_1 = 1/50; \quad G_2 = 1/40; \quad G_3 = 1/20$$

$$\therefore V_{00'} = \frac{(-150/50) + (0/40) + (120/20)}{(1/50) + (1/40) + (1/20)} = 31.6\ \text{V}$$

It shows that point 0 is at a higher potential as compared to point $0'$.

Example 2.113. Calculate the voltage across the $10\ \Omega$ resistor in the network of Fig. 2.227 by using (a) Millman's theorem (b) any other method.

Solution. (a) As shown in the Fig. 2.227 we are required to calculate voltage $V_{00'}$. The four resistances are connected to the common terminal $0'$.

Let their other ends be marked as 1, 2, 3 and 4 as shown in Fig. 2.227. Now potential of point 0 with respect to point 1 is (Art. 1.25) $-100\ \text{V}$ because (see Art. 1.25)

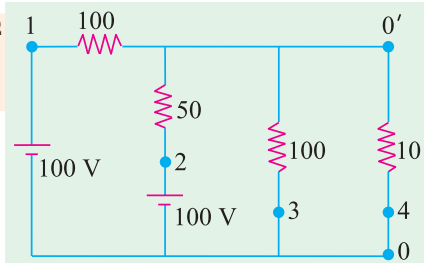

Fig. 2.227

$$\therefore V_{01} = -100\ \text{V}; \quad V_{02} = -100\ \text{V}; \quad V_{03} = 0\ \text{V}; \quad V_{04} = 0\ \text{V}.$$

$$G_1 = 1/100 = 0.01\ \text{Siemens}; \quad G_2 = 1/50 = 0.02\ \text{Siemens};$$

$$G_3 = 1/100 = 0.01\ \text{Siemens}; \quad G_4 = 1/10 = 0.1\ \text{Siemens}$$

$$\begin{aligned} \therefore V_{00'} &= \frac{V_{01}G_1 + V_{02}G_2 + V_{03}G_3 + V_{04}G_4}{G_1 + G_2 + G_3 + G_4} \\ &= \frac{100 \quad 0.01 \quad (-100) \quad 0.02 \quad 0. \quad 0.01 \quad 0 \quad 0.1}{0.01 \quad 0.02 \quad 0.01 \quad 0.1} \quad \frac{3}{0.14} \quad \mathbf{21.4\ \text{V}} \end{aligned}$$

Also, $V_{00'} = -V_{00'} = \mathbf{21.4\ \text{V}}$

(b) We could use the source conversion technique (Art. 2.14) to solve this question. As shown in Fig. 2.228 (a), the two voltage sources and their series resistances have been converted into current sources with their parallel resistances. The two current sources have been combined into a single resistance current source of $3\ \text{A}$ and the three parallel resistances have been combined into a single resistance of $25\ \Omega$. This current source has been reconverted into a voltage source of $75\ \text{V}$ having a series resistance of $25\ \Omega$ as shown in Fig. 2.228 (c).

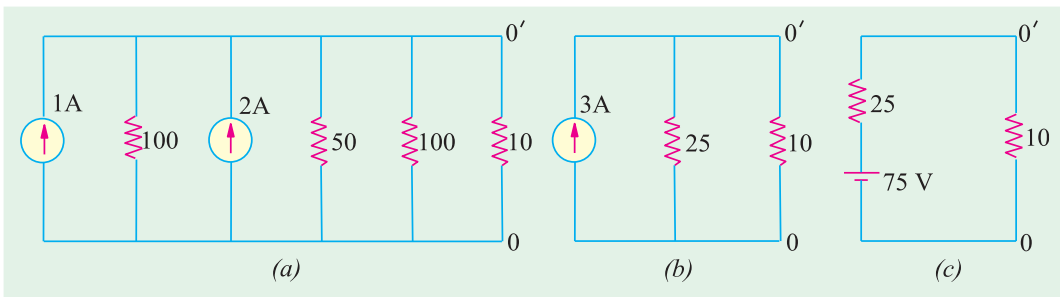

Fig. 2.228

Using the voltage divider formula (Art. 1.15), the voltage drop across $10\ \Omega$ resistance is $V_{0'0} = 75 \times 10/(10 + 25) = 21.4\ \text{V}$.

Example 2.114. In the network shown in Fig. 2.229, using Millman's theorem, or otherwise find the voltage between A and B. (Elect. Engg. Paper-I Indian Engg. Services 1990)

Solution. The end points of the different admittances which are connected directly to the common point B have been marked as 1, 2 and 3 as shown in the Fig. 2.229. Incidentally, $40\ \Omega$ resistance will not be taken into consideration because it is not directly connected to the common point B. Here $V_{01} = V_{A1} = -50\ \text{V}$; $V_{02} = V_{A2} = 100\ \text{V}$; $V_{03} = V_{A3} = 0\ \text{V}$.

$$\therefore V_{00}' = V_{AB} = \frac{(-50/50) + (100/20) + (0/10)}{(1/50) + (1/20) + (1/10)} = 23.5\ \text{V}$$

Since the answer comes out to be positive, it means that point A is at a higher potential as compared to point B.

The detailed reason for not taking any notice of $40\ \Omega$ resistance are given in Art. 2.29.

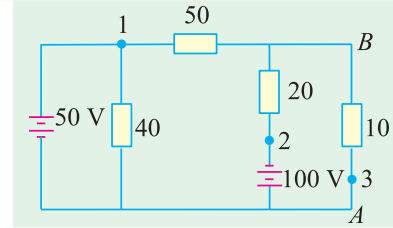

Fig. 2.229

2.30. Maximum Power Transfer Theorem

Although applicable to all branches of electrical engineering, this theorem is particularly useful for analysing communication networks. The overall efficiency of a network supplying maximum power to any branch is 50 per cent. For this reason, the application of this theorem to power transmission and distribution networks is limited because, in their case, the goal is high efficiency and not maximum power transfer.

However, in the case of electronic and communication networks, very often, the goal is either to receive or transmit maximum power (through at reduced efficiency) specially when power involved is only a few milliwatts or microwatts. Frequently, the problem of maximum power transfer is of crucial significance in the operation of transmission lines and antennas.

As applied to d.c. networks, this theorem may be stated as follows :

A resistive load will abstract maximum power from a network when the load resistance is equal to the resistance of the network as viewed from the output terminals, with all energy sources removed leaving behind their internal resistances.

In Fig. 2.230 (a), a load resistance of R_L is connected across the terminals A and B of a network which consists of a generator of e.m.f. E and internal resistance R_g and a series resistance R which, in fact, represents the lumped resistance of the connecting wires. Let $R_i = R_g + R =$ internal resistance of the network as viewed from A and B.

According to this theorem, R_L will abstract maximum power from the network when $R_L = R_i$.

Proof. Circuit current $I = \frac{E}{R_L + R_i}$

Power consumed by the load is

$$P_L = I^2 R_L = \frac{E^2 R_L}{(R_L + R_i)^2} \quad \dots(i)$$

For P_L to be maximum, $\frac{dP_L}{dR_L} = 0$.

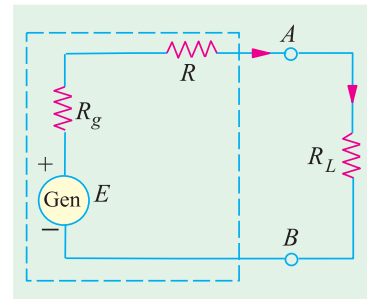

Fig. 2.230

Differentiating Eq. (i) above, we have

$$\frac{dP_L}{dR_L} = E^2 \left[\frac{1}{(R_L + R_i)^2} + R_L \left(\frac{-2}{(R_L + R_i)^3} \right) \right] = E^2 \left[\frac{1}{(R_L + R_i)^2} - \frac{2R_L}{(R_L + R_i)^3} \right]$$

$$\therefore 0 = E^2 \left[\frac{1}{(R_L + R_i)^2} - \frac{2R_L}{(R_L + R_i)^3} \right] \quad \text{or} \quad 2R_L = R_L + R_i \quad \text{or} \quad R_L = R_i$$

It is worth noting that under these conditions, the voltage across the load is hold the open-circuit voltage at the terminals A and B .

$$\therefore \text{Max. power is } P_{L \max.} = \frac{E^2 R_L}{4 R_L^2} = \frac{E^2}{4 R_L} = \frac{E^2}{4 R_i}$$

Let us consider an a.c. source of internal impedance $(R_1 + jX_1)$ supplying power to a load impedance $(R_L + jX_L)$. It can be proved that maximum power transfer will take place when the modulus of the load impedance is equal to the modulus of the source impedance i.e. $|Z_L| = |Z_1|$

Where there is a completely free choice about the load, the maximum power transfer is obtained when load impedance is the complex conjugate of the source impedance. For example, if source impedance is $(R_1 + jX_1)$, then maximum transfer power occurs, when load impedance is $(R_1 - jX_1)$. It can be shown that under this condition, the load power is $= E^2/4R_1$.

Example 2.115. In the network shown in Fig. 2.231 (a), find the value of R_L such that maximum possible power will be transferred to R_L . Find also the value of the maximum power and the power supplied by source under these conditions. **(Elect. Engg. Paper I Indian Engg. Services)**

Solution. We will remove R_L and find the equivalent Thevenin's source for the circuit to the left of terminals A and B . As seen from Fig. 2.231 (b) V_{th} equals the drop across the vertical resistor of 3Ω because no current flows through 2Ω and 1Ω resistors. Since 15 V drops across two series resistors of 3Ω each, $V_{th} = 15/2 = 7.5\text{ V}$. Thevenin's resistance can be found by replacing 15 V source with a short-circuit. As seen from Fig. 2.231 (b), $R_{th} = 2 + (3 \parallel 3) + 1 = 4.5\Omega$. Maximum power transfer to the load will take place when $R_L = R_{th} = 4.5\Omega$

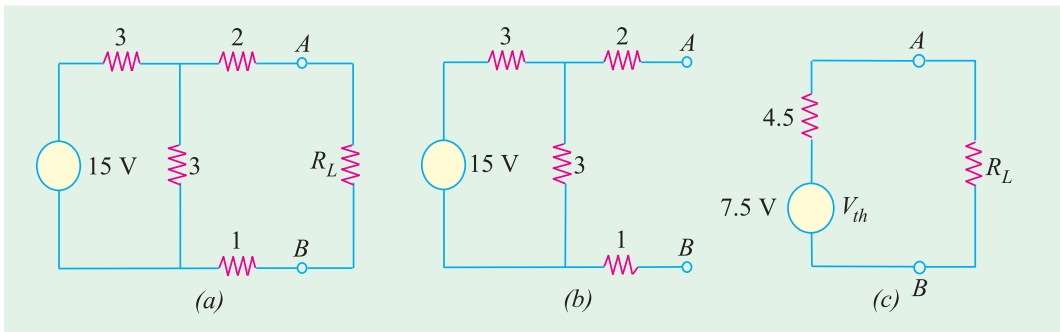

Fig. 2.231

Maximum power drawn by $R_L = V_{th}^2/4 \times R_L = 7.5^2/4 \times 4.5 = 3.125\text{ W}$.

Since same power is developed in R_{th} , power supplied by the source $= 2 \times 3.125 = 6.250\text{ W}$.

Example 2.116. In the circuit shown in Fig. 2.232 (a) obtain the condition for maximum power transfer to the load R_L . Hence determine the maximum power transferred.

(Elect. Science-I Allahabad Univ. 1992)

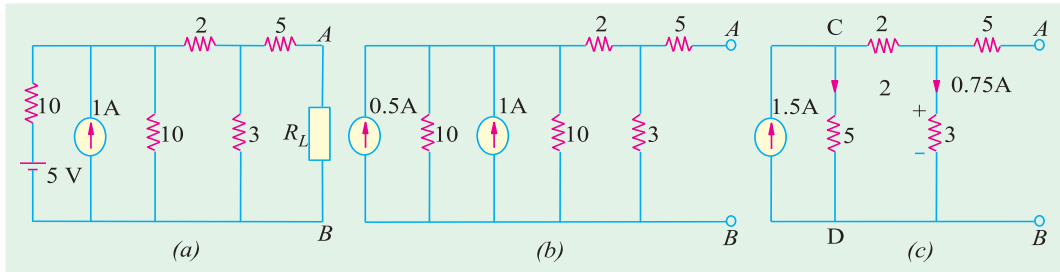

Fig. 2.232

Solution. We will find Thevenin's equivalent circuit to the left of terminals A and B for which purpose we will convert the battery source into a current source as shown in Fig. 2.232 (b). By combining the two current sources, we get the circuit of Fig. 2.232 (c). It would be seen that open circuit voltage V_{AB} equals the drop over 3Ω resistance because there is no drop on the 5Ω resistance connected to terminal A. Now, there are two parallel path across the current source each of resistance 5Ω . Hence, current through 3Ω resistance equals $1.5/2 = 0.75\text{ A}$. Therefore, $V_{th} = V_{th} = 3 \times 0.75 = 2.25\text{ V}$ with point A positive with respect to point B.

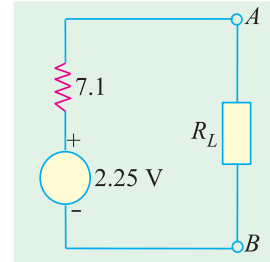

Fig. 2.233

For finding R_{AB} , current source is replaced by an infinite resistance.

$$\therefore R_{AB} = R_{th} = 5 + 3 \parallel (2 + 5) = 7.1\ \Omega$$

The Thevenin's equivalent circuit alongwith R_L is shown in Fig. 2.233. As per Art. 2.30, the condition for MPT is that $R_L = 7.1\ \Omega$

$$\text{Maximum power transferred} = V_{th}^2 / 4R_L = 2.25^2 / 4 \times 7.1 = 0.178\text{ W} = 178\text{ mW}.$$

Example 2.117. Calculate the value of R which will absorb maximum power from the circuit of Fig. 2.234 (a). Also, compute the value of maximum power.

Solution. For finding power, it is essential to know both I and R . Hence, it is essential to find an equation relating I to R .

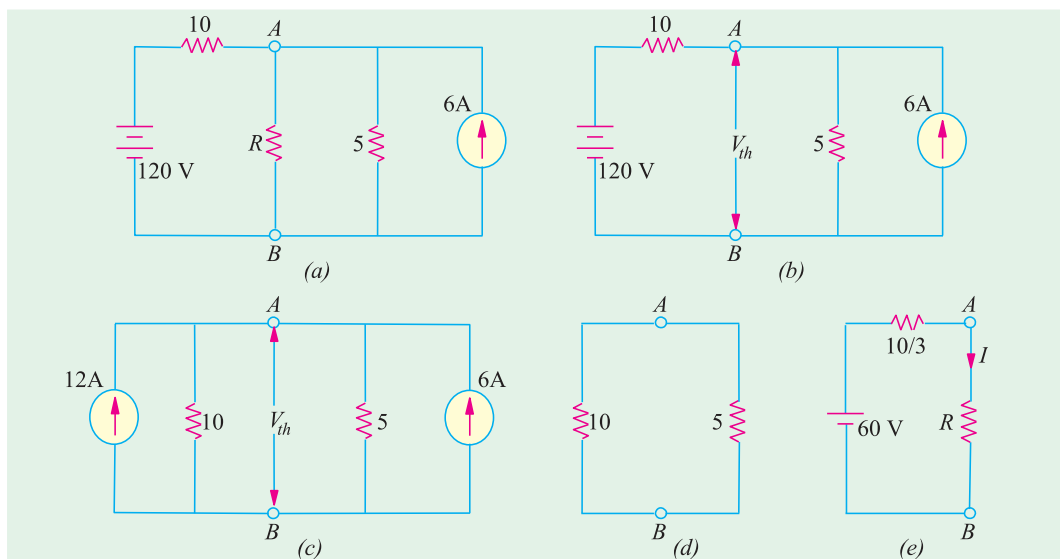

Fig. 2.234

Let us remove R and find Thevenin's voltage V_{th} across A and B as shown in Fig. 2.234 (b). It would be helpful to convert 120 V, 10- Ω source into a constant-current source as shown in Fig. 2.234 (c). Applying KCL to the circuit, we get

$$\frac{V_{th}}{10} + \frac{V_{th}}{5} = 12 + 6 \quad \text{or} \quad V_{th} = 60 \text{ V}$$

Now, for finding R_i and R_{th} , the two sources are reduced to zero. Voltage of the voltage-source is reduced to zero by short-circuiting it whereas current of the current source is reduced to zero by open-circuiting it. The circuit which results from such source suppression is shown in Fig. 2.234 (d). Hence, $R_i = R_{th} = 10 \parallel 5 = 10/3 \Omega$. The Thevenin's equivalent circuit of the network is shown in Fig. 2.234 (e).

According to Maximum Power Transfer Theorem, R will absorb maximum power when it equals $10/3 \Omega$. In that case, $I = 60 \div 20/3 = 9 \text{ A}$

$$P_{max} = I^2 R = 9^2 \times 10/3 = 270 \text{ W}$$

2.31. Power Transfer Efficiency

If P_L is the power supplied to the load and P_T is the total power supplied by the voltage source, then power transfer efficiency is given by $\eta = P_L/P_T$.

Now, the generator or voltage source E supplies power to both the load resistance R_L and to the internal resistance $R_i = (R_g + R)$.

$$P_T = P_L + P_i \quad \text{or} \quad E \times I = I^2 R_L + I^2 R_i$$

$$\therefore \eta = \frac{P_L}{P_T} = \frac{I^2 R_L}{I^2 R_L + I^2 R_i} = \frac{R_L}{R_L + R_i} = \frac{1}{1 + (R_i / R_L)}$$

The variation of η with R_L is shown in Fig. 2.235 (a). The maximum value of η is unity when $R_L = \infty$ and has a value of 0.5 when $R_L = R_i$. It means that under maximum power transfer conditions, the power transfer efficiency is only 50%. As mentioned above, maximum power transfer condition is important in communication applications but in most power systems applications, a 50% efficiency is undesirable because of the wasted energy. Often, a compromise has to be made between the load power and the power transfer efficiency. For example, if we make $R_L = 2 R_i$, then

$$P_L = 0.222 E^2 / R_i \quad \text{and} \quad \eta = 0.667.$$

It is seen that the load power is only 11% less than its maximum possible value, whereas the power transfer efficiency has improved from 0.5 to 0.667 *i.e.* by 33%.

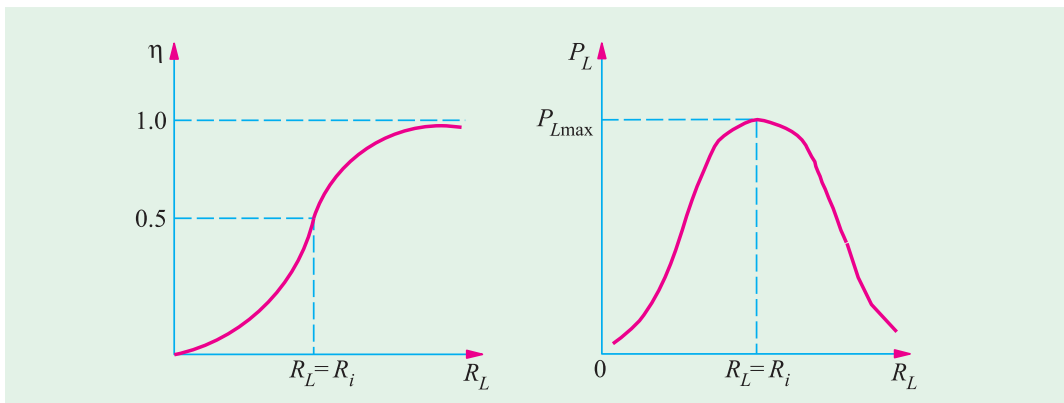

Fig. 2.235

Example 2.118. A voltage source delivers 4 A when the load connected to it is 5 Ω and 2 A when the load becomes 20 Ω . Calculate

(a) maximum power which the source can supply (b) power transfer efficiency of the source with R_L of 20 Ω (c) the power transfer efficiency when the source delivers 60 W.

Solution. We can find the values of E and R_i from the two given load conditions.

(a) When $R_L = 5 \Omega$, $I = 4$ A and $V = IR_L = 4 \times 5 = 20$ V, then $20 = E - 4 R_i$...**(i)**

When $R_L = 20 \Omega$, $I = 2$ A and $V = IR_L = 2 \times 20 = 40$ V $\therefore 40 = E - 2 R_i$...**(ii)**

From **(i)** and **(ii)**, we get, $R_i = 10 \Omega$ and $E = 60$ V

When $R_L = R_i = 10 \Omega$

$$P_{L \max} = \frac{E^2}{4R_i} = \frac{60 \times 60}{4 \times 10} = 90 \text{ W}$$

(b) When $R_L = 20 \Omega$, the power transfer efficiency is given by

$$\eta = \frac{R_L}{R_L + R_i} = \frac{20}{30} = 0.667 \text{ or } 66.7\%$$

(c) For finding the efficiency corresponding to a load power of 60 W, we must first find the value of R_L .

Now,
$$P_L = \left(\frac{E}{R_i + R_L} \right)^2 R_L$$

$$\therefore 60 = \frac{60^2 \times R_L}{(R_L + 10)^2} \text{ or } R_L^2 - 40 R_L + 100 = 0$$

Hence
$$R_L = 37.32 \Omega \text{ or } 2.68 \Omega$$

Since there are two values of R_L , there are two efficiencies corresponding to these values.

$$\eta_1 = \frac{37.32}{37.32 + 10} = 0.789 \text{ or } 78.9\%, \quad \eta_2 = \frac{2.68}{12.68} = 0.211 \text{ or } 21.1\%$$

It will be seen from above, the $\eta_1 + \eta_2 = 1$.

Example 2.119. Two load resistance R_1 and R_2 dissipate the same power when connected to a voltage source having an internal resistance of R_i . Prove that (a) $R_i^2 = R_1 R_2$ and (b) $\eta_1 + \eta_2 = 1$.

Solution. (a) Since both resistances dissipate the same amount of power, hence

$$P_L = \frac{E^2 R_1}{(R_1 + R_i)^2} = \frac{E^2 R_2}{(R_2 + R_i)^2}$$

Cancelling E^2 and cross-multiplying, we get

$$R_1 R_2^2 + 2R_1 R_2 R_i + R_1 R_i^2 = R_2 R_1^2 + 2R_1 R_2 R_i + R_2 R_i^2$$

Simplifying the above, we get, $R_i^2 = R_1 R_2$

(b) If η_1 and η_2 are the two efficiencies corresponding to the load resistances R_1 and R_2 , then

$$\eta_1 + \eta_2 = \frac{R_1}{R_1 + R_i} + \frac{R_2}{R_2 + R_i} = \frac{2R_1 R_2 + R_i(R_1 + R_2)}{R_1 R_2 + R_i^2 + R_i(R_1 + R_2)}$$

Substituting $R_i^2 = R_1 R_2$, we get

$$\eta_1 + \eta_2 = \frac{2R_1 R_2 + R_i(R_1 + R_2)}{2R_1 R_2 + R_i(R_1 + R_2)} = 1$$

Example 2.120. Determine the value of R_L for maximum power at the load. Determine maximum power also. The network is given in the Fig. 2.236 (a). [Bombay University 2001]

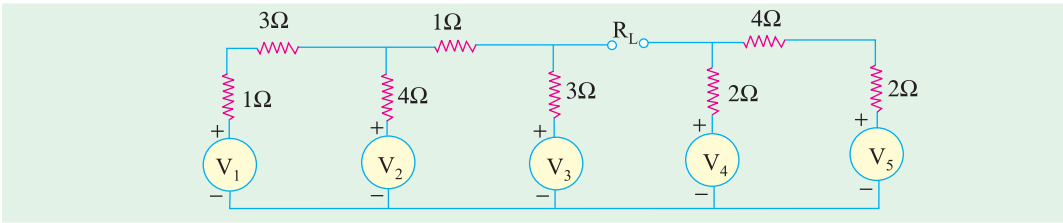

Fig. 2.236 (a)

Solution. This can be attempted by Thevenin's Theorem. As in the circuit, with terminals A and B kept open, from the right hand side, V_B (w.r. to reference node 0) can be calculated V_4 and V_5 will have a net voltage of 2 volts circulating a current of $(2/8) = 0.25$ amp in clockwise direction.

$$V_B = 10 - 0.25 \times 2 = 9.5 \text{ volts.}$$

On the Left-hand part of the circuit, two loops are there. V_A (w.r. to 0) has to be evaluated. Let the first loop (with V_1 and V_2 as the sources) carry a clockwise current of i_1 and the second loop (with V_2 and V_3 as the sources), a clockwise current of i_2 . Writing the circuit equations.

$$\begin{aligned} 8i_1 - 4i_2 &= +4 \\ -4i_1 + 8i_2 &= +4 \end{aligned}$$

This gives $i_1 = 1$ amp, $i_2 = 1$ amp

Therefore, $V_A = 12 + 3 \times 1 = 15$ volts.

Thevenin -voltage, $V_{TH} = V_A - V_B = 15 - 9.5 = 5.5$ volts

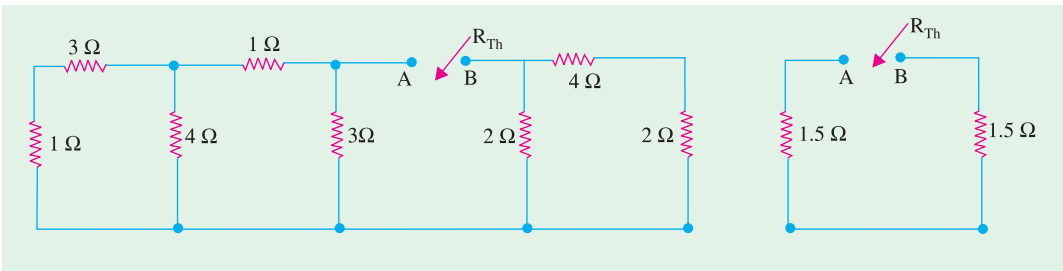

Fig. 2.236 (b)

Fig. 2.236 (c)

Solving as shown in Fig. 2.236 (b) and (c).

$$R_{TH} = 3 \text{ ohms}$$

For maximum power transfer, $R_L = 3$ ohms

$$\text{Current} = 5.5/6 = 0.9167 \text{ amp}$$

$$\text{Power transferred to load } 0.9167^2 \times 3 = 2.52 \text{ watts.}$$

Example 2.121. For the circuit shown below, what will be the value of R_L to get the maximum power? What is the maximum power delivered to the load? [Bombay University 2001]

Solution. Detach R_L and apply Thevenin's Theorem.

$$V_{TH} = 5.696 \text{ volts, } R_{TH} = 11.39 \Omega$$

R_L must be 11.39 ohms for maximum power transfer.

$$P_{\max} = 0.712 \text{ watt.}$$

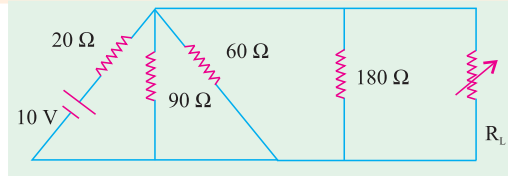

Fig. 2.237

Example 2.122. Find the maximum power in ' R_L ' which is variable in the circuit shown below in Fig. 2.238. [Bombay University, 2001]

Solution. Apply Thevenin's theorem. For this R_L has to be detached from nodes A and B. Treat O as the reference node.

$$V_A = 60 \text{ V}, V_B = V_C + 2 = 50 + 2 = 52 \text{ V}$$

Thus, $V_{TH} = V_{AB} = 8$ volts, with A positive w.r. to B, $R_{TH} = (60//40) + (50//50) = 49$ ohms

Hence, for maximum power, $R_L = 49$ ohms

With this R_L , Current = $8/98$ amp = 0.08163 amp

Power to Load = $i^2 R_L = 0.3265$ watt

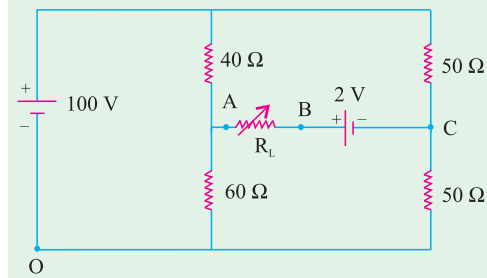

Fig. 2.238

Example 2.123. Find V_A and V_B by "nodal analysis" for the circuit shown in Fig. 2.239 (a). [Bombay University]

Solution. Let the conductance be represented by g . Let all the sources be current sources. For this, a voltage-source in series with a resistor is transformed into its equivalent current source. This is done in Fig. 2.239 (b).

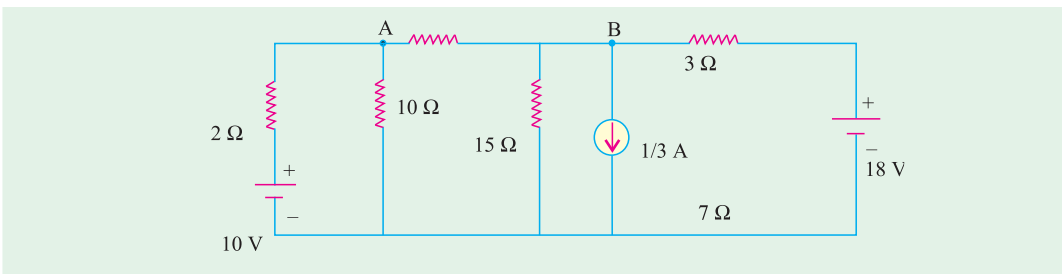

Fig. 2.239 (a)

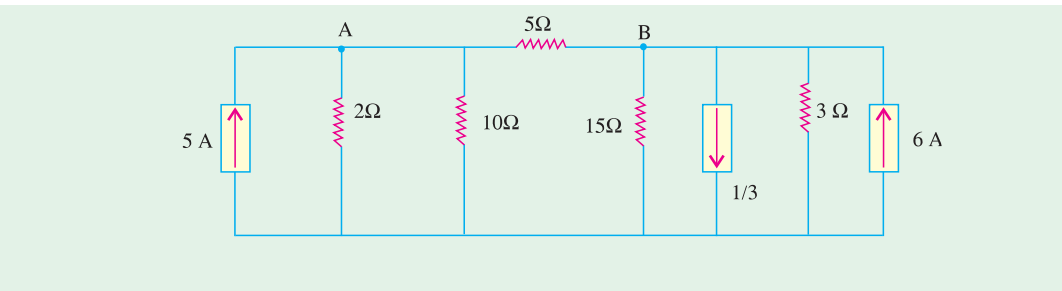

Fig. 2.239 (b). All Current Sources

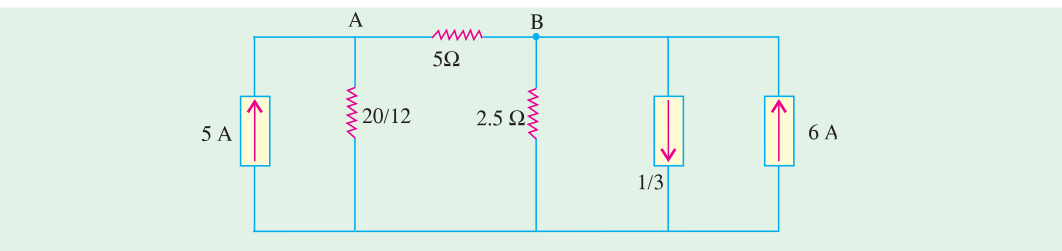

Fig. 2.239 (c)

Observing the circuit, $g_{11} = (1/5) + 0.6 = 0.8$, $g_{22} = 0.40 + 0.2 = 0.6$
 $g_{12} = 0.2$, Current sources : + 5 amp into 'A' + 5.67 amp into 'B'

$$\Delta = \begin{bmatrix} 0.8 & -0.2 \\ -0.2 & 0.6 \end{bmatrix} = 0.44$$

$$\Delta_1 = \begin{bmatrix} 5 & -0.2 \\ 5.67 & 0.6 \end{bmatrix} = 4.134$$

$$\Delta_2 = \begin{bmatrix} 0.8 & 5 \\ -0.2 & 5.67 \end{bmatrix} = 5.526$$

$$V_A = 4.134/0.44 = 9.4 \text{ volts,}$$

$$V_B = 5.536/0.44 = 12.6 \text{ volts.}$$

Current in 5-ohm resistor

$$= (V_B - V_A)/5 = 0.64 \text{ amp}$$

Check : Apply Thevenin's Theorem :

$$V_A = 10 \times (10/12) = 8.333 \text{ V}$$

$$V_B = (17/3) \times 2.5 = 14.167 \text{ V}$$

$$V_{TH} = 14.167 - 8.333 = 5.834 \text{ V}$$

$$R_{TH} = 4.167$$

$$I_5 = 5.834/(4.167 + 5) = 0.64 \text{ A}$$

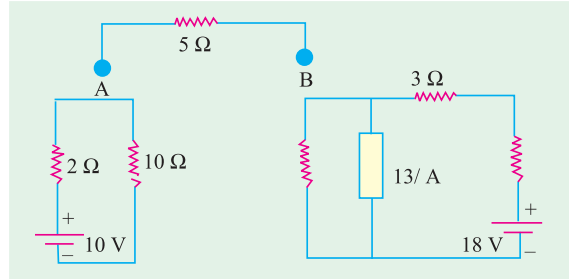

Fig. 2.239 (d) Thevenized Circuit

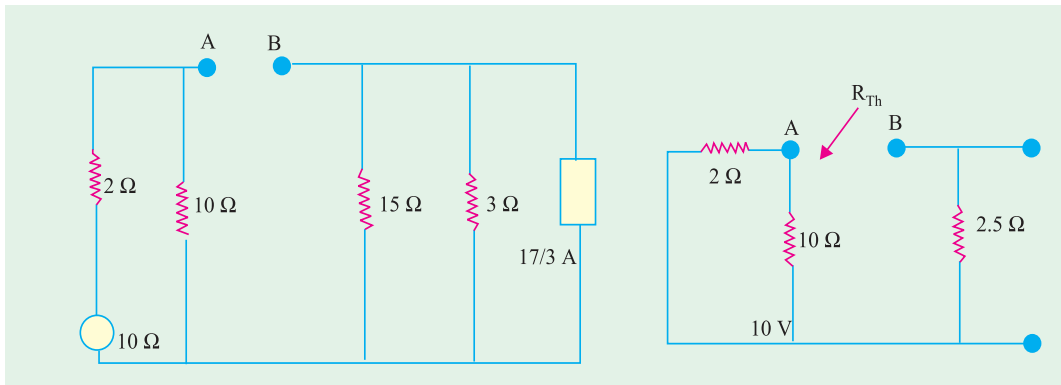

Fig. 2.239 (e) Right side simplified

Fig. 2.239 (f) Evaluating R_{TH}

Example. 2.124. Find the magnitude R_L for the maximum power transfer in the circuit shown in Fig. 2.240 (a). Also find out the maximum power.

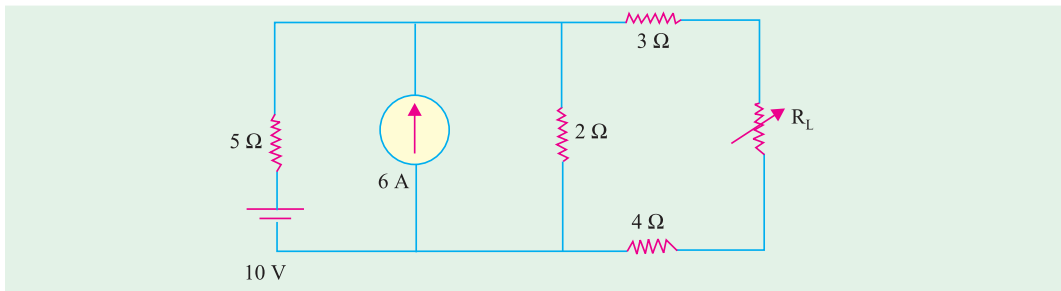

Fig. 2.240 (a)

Solution. Simplify by source transformations, as done in Fig. 2.240 (b), (c), (d)

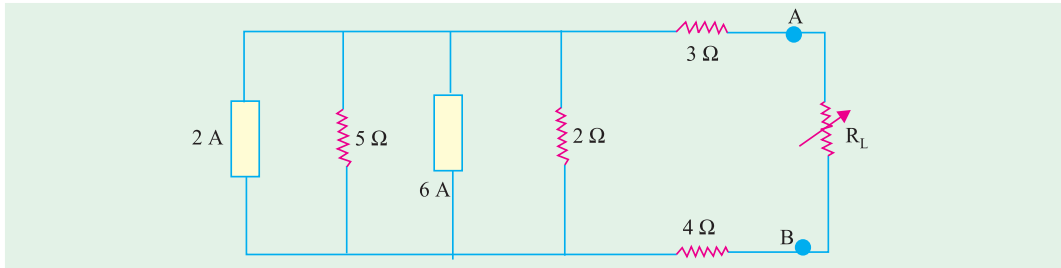

Fig. 2.240 (b)

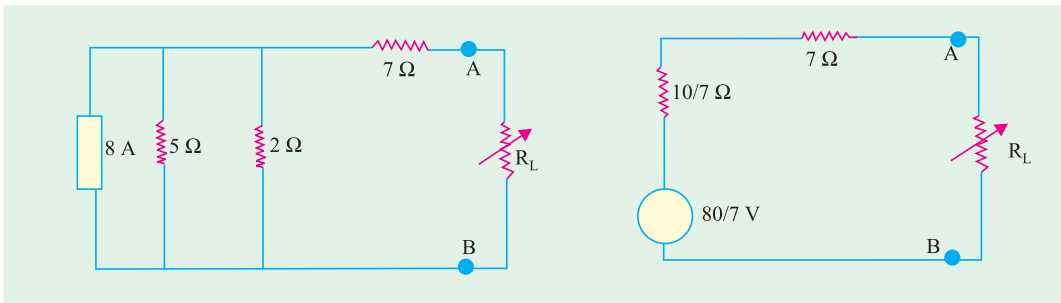

Fig. 2.240 (c)

Fig. 2.240 (d)

$$\begin{aligned} \text{For maximum power, } R_L &= 7 + (10/7) = 8.43 \, \Omega \\ \text{Maximum power} &= [(80/7)/16.68]^2 \times 8.43 = 3.87 \text{ watts.} \end{aligned}$$

Tutorial Problems No. 2.6

(a) Norton Theorem

- Find the Thevenin and Norton equivalent circuits for the active network shown in Fig. 2.241 (a). All resistance are in ohms. **[Hint : Use Superposition principle to find contribution of each source]**
[10 V source, series resistor = 5 Ω ; 2 A source, parallel resistance = 5 Ω]
- Obtain the Thevenin and Norton equivalent circuits for the circuit shown in Fig. 2.241 (b). All resistance values are in ohms.
[15 V source, series resistance = 5 Ω ; 3 A source, parallel resistance = 5 Ω]

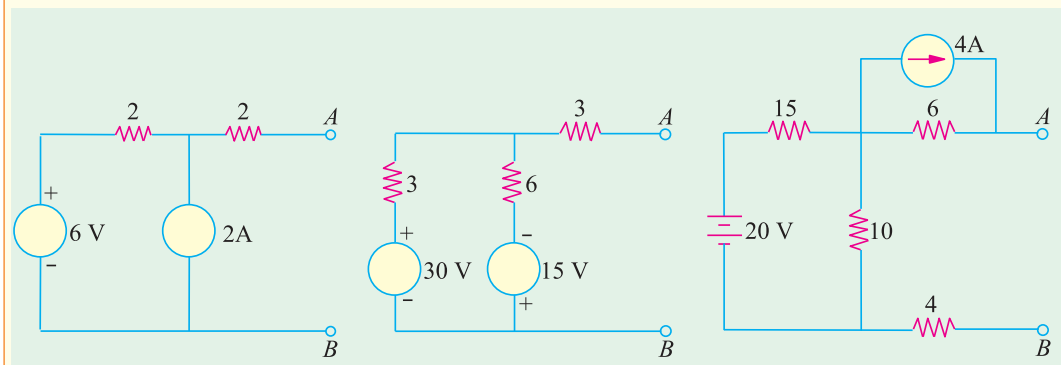

Fig. 2.241 (a)

Fig. 2.241 (b)

Fig. 2.241 (c)

- Find the Norton equivalent circuit for the active linear network shown in Fig. 2.241 (c). All resistances are in ohms. **Hint :** It would be easier to first find Thevenin's equivalent circuit].
[2 A source; parallel resistance = 16 Ω]

- Find Norton's equivalent circuit for the network shown in Fig. 2.249. Verify it through its Thevenin's equivalent circuit. [1 A, Parallel resistance = 6 Ω]
- State the Tellegen's theorem and verify it by an illustration. Comment on the applicability of Tellegen's theorem on the types of networks. (Circuit and Field Theory, A.M.I.E. Sec. B, 1993)

Solution. Tellegen's Theorem can be stated as under :

For a network consisting of n elements if i_1, i_2, \dots, i_n are the currents flowing through the elements satisfying Kirchhoff's current law and v_1, v_2, \dots, v_n are the voltages across these elements satisfying Kirchhoff's law, then

$$\sum_{k=1}^n v_k i_k = 0$$

where v_k is the voltage across and i_k is the current through the k_{th} element. In other words, according to Tellegen's Theorem, the sum of instantaneous powers for the n branches in a network is always zero.

This theorem has wide applications. It is valid for any lumped network that contains any elements linear or non-linear, passive or active, time-variant or time-invariant.

Explanation : This theorem will be explained with the help of the simple circuit shown in Fig. 2.242. The total resistance seen by the battery is $8 + 4 \parallel 4 = 10 \Omega$

Battery current $I = 100/10 = 10$ A. This current divides equally at point B,

- Drop over 8 Ω resistor = $8 \times 10 = 80$ V
- Drop over 4 Ω resistor = $4 \times 5 = 20$ V
- Drop over 1 Ω resistor = $1 \times 5 = 5$ V
- Drop over 3 Ω resistor = $3 \times 5 = 15$ V

According to Tellegen's Theorem,
 $= 100 \times 10 - 80 \times 10 - 20 \times 5 - 5 \times 5 - 15 \times 5 = 0$

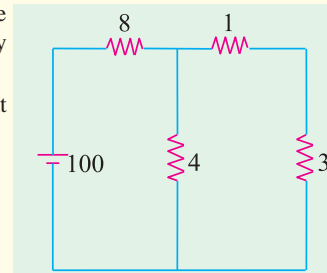

Fig. 2.242

(b) Millman's Theorem

- Use Millman's theorem, to find the potential of point A with respect to the ground in Fig. 2.243. [$V_A = 8.18$ V]
- Using Millman's theorem, find the value of output voltage V_0 in the circuit of Fig. 2.244. All resistances are in ohms. [4 V]

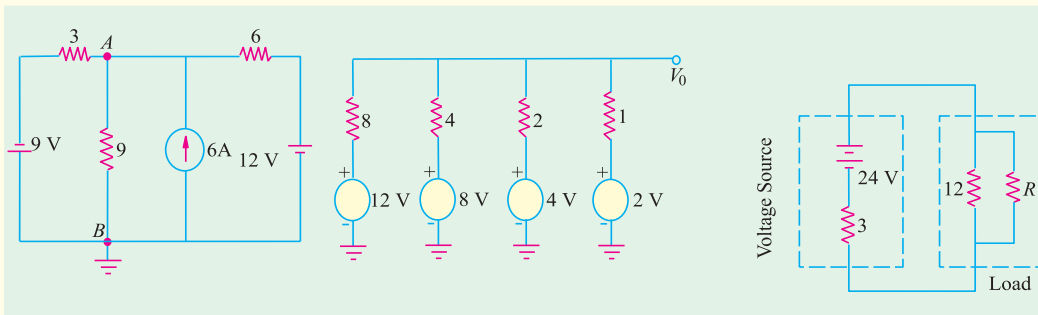

Fig. 2.243

Fig. 2.244

Fig. 2.245

(b) MPT Theorem

- In Fig. 2.245 what value of R will allow maximum power transfer to the load ? Also calculate the maximum total load power. All resistances are in ohms. [4 Ω ; 48 W]
- Use superposition theorem to find currents in various branches of the ckt in Fig. 2.246. (B.P.T.U., Orissa 2003) (Nagpur University, Summer 2002)

10. Find the resistance between point A and B for the circuit shown in Fig. 2.247.

(Nagpur University, Winter 2002)

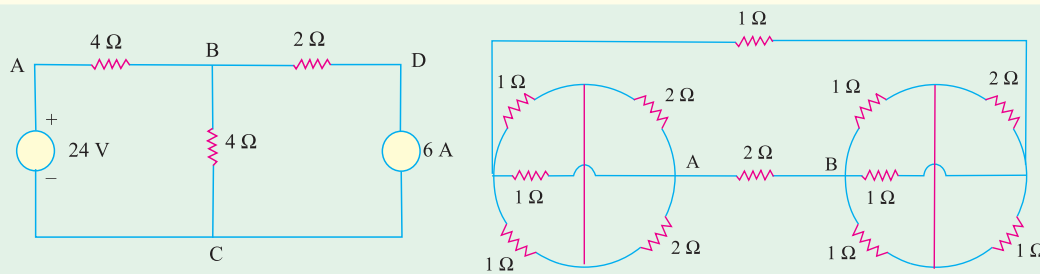

Fig. 2.246

Fig. 2.247

11. Apply the superposition theorem and find the current through 25 ohm resistance of the circuit shown in Fig. 2.248.

(Mumbai University 2002) (Nagpur University, Summer 2003)

12. Find the total current flowing through the circuit shown in Fig. 2.249 using star-delta transformation if the circuit is excited by 39 volts and the value of each resistor connected in circuit is 4 ohms.

(Ravishankar University, Raipur 2003) (Nagpur University, Summer 2003)

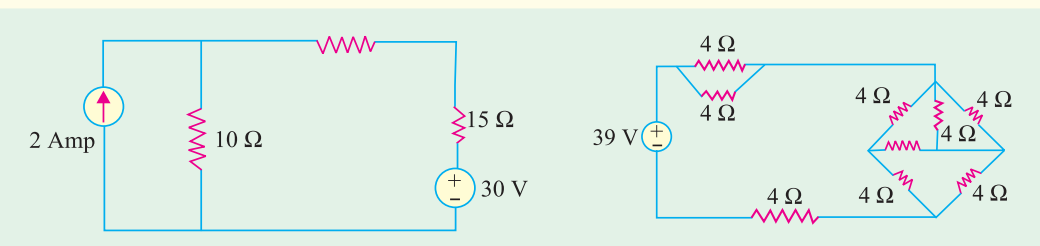

Fig. 2.248

Fig. 2.249

13. Compute the power dissipated in the 9 ohm resistor in the Fig. 2.250 by applying Superposition Theorem. The voltage and current sources should be treated as ideal. All resistances are in ohm.

(Mumbai University 2003) (Nagpur University, Winter 2003)

14. Find the current in 11 ohm resistor in the Fig. 2.251 using star/delta conversion. All resistances are in ohm.

(Nagpur University, Winter 2003)

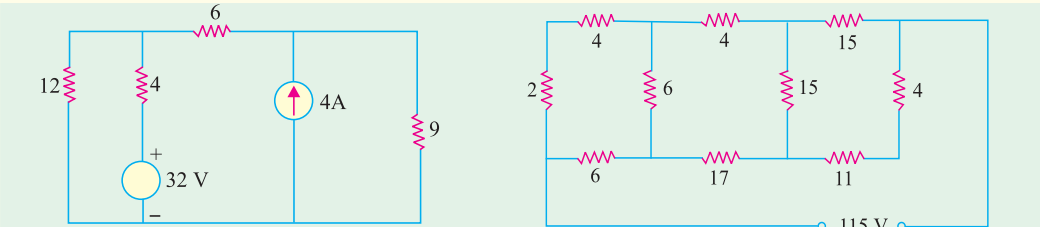

Fig. 2.250

Fig. 2.251

15. Calculate current-flowing through “2 ohms” resistor in Fig. 2.252 by using Superposition theorem.

(Mumbai University 2003) (Nagpur University, Summer 2004)

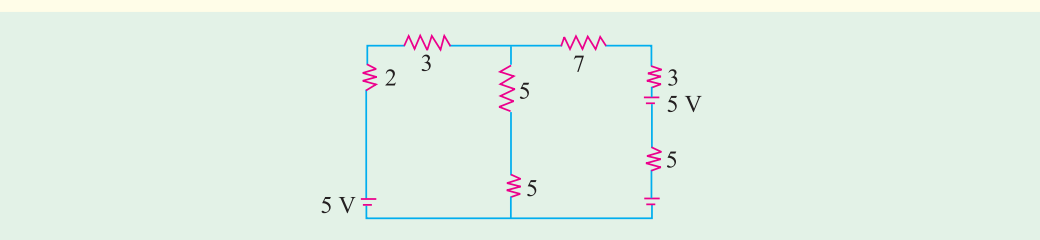

Fig. 2.252. All resistance are in ohms.

16. State and explain Superposition Theorem. *(Pune University 2003) (Nagpur University, Summer 2004)*
17. A cast iron ring of 40 cm diameter is wound with a coil. The coil carries a current of 3 amp and produces a flux of 3 mwb in the air gap. The length of air gap is 2 mm. The relative permeability of the cast iron is 800. The leakage coefficient is 1.2. Calculate no. of turns of the coil. *(Nagpur University, Summer 2004)*
18. Using superposition theorem, calculate the current I_{AB} in the given circuit of Fig. 2.253. *(Gujrat University, Summer 2003)*
19. Using delta-star transformation, determine the current drawn from the source in the given circuit Fig.2.254. *(Gujrat University, Summer 2003)*

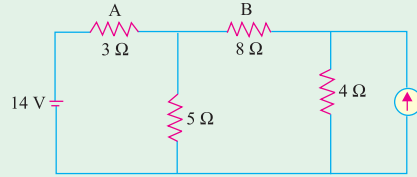

Fig. 2.253

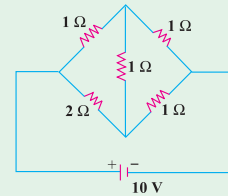

Fig. 2.254

20. State and explain Kirchoff's laws applied to electric circuit. *(Gujrat University, Summer2003)*
21. State Kirchoff's laws. *(Madras University, April 2002)*
22. Three resistances R_{ab} , R_{bc} and R_{ca} are connected in delta. Obtain expressions for their equivalent star resistances. *(V.T.U., Belgaum Karnataka University, February 2002)*
23. In the circuit, shown in Fig. 2.255 determine the value of E so that the current I = 0. Use mesh method of analysis. *(V.T.U., Belgaum Karnataka University, January/February 2004)*
24. In Fig. 2.256 derive the expressions to replace a delta connected resistances by an equivalent star connected resistances. Determine the resistance between a and b. All the resistance and 1Ω each. *(V.T.U., Belgaum Karnataka University, January/February 2004)*

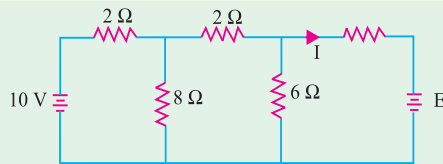

Fig. 2.255

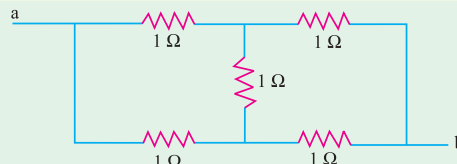

Fig. 2.256

25. Determine the values of I and R in the circuit shown in the Fig. 2.257. *(ESE 2003)*
26. In the circuit shown in the Fig. 2.258, S is closed at time $t=0$. Determine $i_c(t)$ and the time constant. *(Pune University 2003) (ESE 2003)*
27. In the circuit shown in the Fig. 2.259. S is closed at $t=0$. Find the current $i_c(t)$ through the capacitor at $t=0$. *(Pune University 2003) (ESE 2003)*

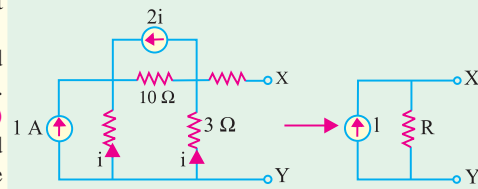

Fig. 2.257

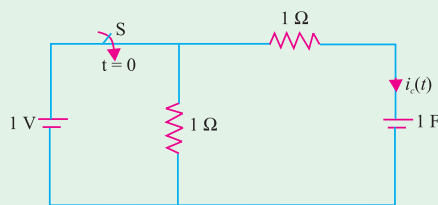

Fig. 2.258

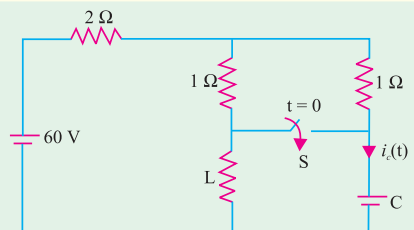

Fig. 2.259

OBJECTIVE TESTS – 2

- Kirchhoff's current law is applicable to only
 - closed loops in a network
 - electronic circuits
 - junctions in a network
 - electric circuits.
- Kirchhoff's voltage law is concerned with
 - IR drops
 - battery e.m.fs.
 - junction voltages
 - both (a) and (b)
- According to KVL, the algebraic sum of all IR drops and e.m.f.s in any closed loop of a network is always
 - zero
 - positive
 - negative
 - determined by battery e.m.fs.
- The algebraic sign of an IR drop is primarily dependent upon the
 - amount of current flowing through it
 - value of R
 - direction of current flow
 - battery connection.
- Maxwell's loop current method of solving electrical networks
 - uses branch currents
 - utilizes Kirchhoff's voltage law
 - is confined to single-loop circuits
 - is a network reduction method.
- Point out of the WRONG statement. In the node-voltage technique of solving networks, choice of a reference node does not
 - affect the operation of the circuit
 - change the voltage across any element
 - alter the p.d. between any pair of nodes
 - affect the voltages of various nodes.
- For the circuit shown in the given Fig. 2.260, when the voltage E is 10 V, the current i is 1 A. If the applied voltage across terminal C-D is 100 V, the short circuit current

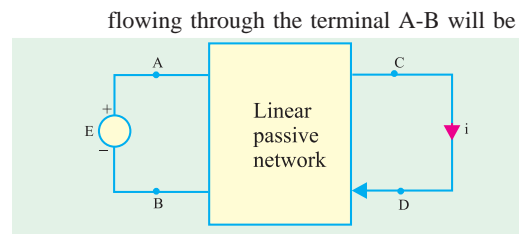

Fig. 2.260

- 0.1 A
 - 1 A
 - 10 A
 - 100 A
- (ESE 2001)

- The component inductance due to the internal flux-linkage of a non-magnetic straight solid circular conductor per metre length, has a constant value, and is independent of the conductor-diameter, because
 - All the internal flux due to a current remains concentrated on the peripheral region of the conductor.
 - The internal magnetic flux-density along the radial distance from the centre of the conductor increases proportionately to the current enclosed
 - The entire current is assumed to flow along the conductor-axis and the internal flux is distributed uniformly and concentrically
 - The current in the conductor is assumed to be uniformly distributed throughout the conductor cross-section

(ESE 2003)

- Two ac sources feed a common variable resistive load as shown in Fig. 2.261. Under the maximum power transfer condition, the power absorbed by the load resistance R_L is

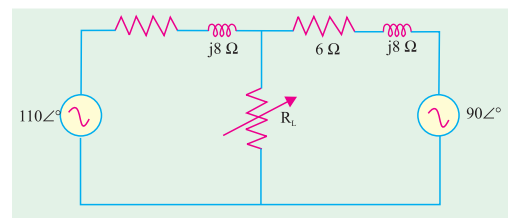

Fig. 2.261

- 2200 W
 - 1250 W
 - 1000 W
 - 625 W
- (GATE 2003)

ANSWERS

1. c 2. d 3. a 4. c 5. b 6. d