

C H A P T E R 5

Learning Objectives

- Capacitor
- Capacitance
- Capacitance of an Isolated Sphere
- Spherical Capacitor
- Parallel-plate Capacitor
- Special Cases of Parallel-plate Capacitor
- Multiple and Variable Capacitors
- Cylindrical Capacitor
- Potential Gradient in Cylindrical Capacitor
- Capacitance Between two Parallel Wires
- Capacitors in Series
- Capacitors in Parallel
- Cylindrical Capacitor with Compound Dielectric
- Insulation Resistance of a Cable Capacitor
- Energy Stored in a Capacitor
- Force of Attraction Between Oppositely-charged Plates
- Current-Voltage Relationships in a Capacitor
- Charging of a Capacitor
- Time Constant
- Discharging of a Capacitor
- Transient Relations during Capacitor Charging Cycle
- Transient Relations during Capacitor Discharging Cycle
- Charging and Discharging of a Capacitor with Initial Charge

CAPACITANCE

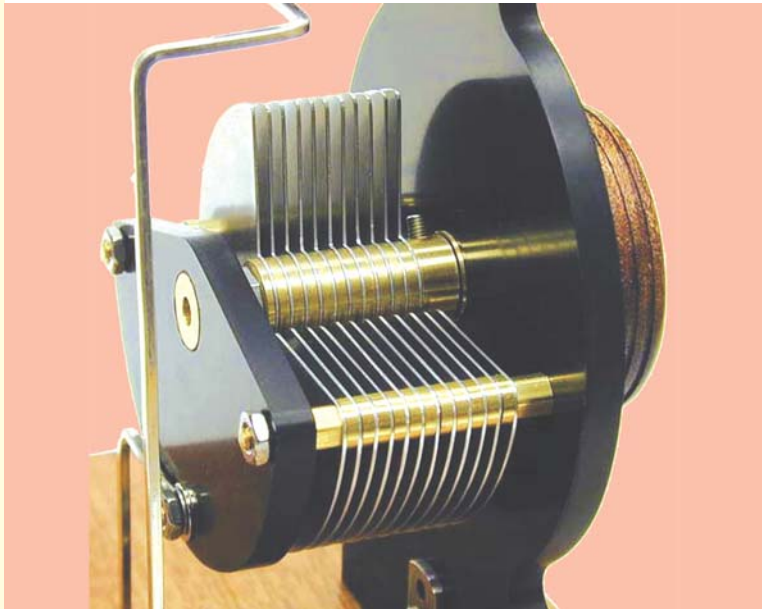

The above figure shows a variable capacitor. A capacitor stores electric charge and acts a small reservoir of energy

5.1. Capacitor

A capacitor essentially consists of two conducting surfaces separated by a layer of an insulating medium called *dielectric*. The conducting surfaces may be in the form of either circular (or rectangular) plates or be of spherical or cylindrical shape. The purpose of a capacitor is to store electrical energy by electrostatic stress in the dielectric (the word ‘condenser’ is a misnomer since a capacitor does not ‘condense’ electricity as such, it merely stores it).

A parallel-plate capacitor is shown in Fig. 5.1. One plate is joined to the positive end of the supply and the other to the negative end or is earthed. It is experimentally found that in the presence of an earthed plate *B*, plate *A* is capable of withholding more charge than when *B* is not there. When such a capacitor is put across a battery, there is a momentary flow of electrons from *A* to *B*. As negatively-charged electrons are withdrawn from *A*, it becomes positive and as these electrons collect on *B*, it becomes negative. Hence, a p.d. is established between plates *A* and *B*. The transient flow of electrons gives rise to charging current. The strength of the charging current is maximum when the two plates are uncharged but it then decreases and finally ceases when p.d. across the plates becomes slowly and slowly equal and opposite to the battery e.m.f.



Fig. 5.1

5.2. Capacitance

The property of a capacitor to ‘store electricity’ may be called its capacitance.

As we may measure the capacity of a tank, not by the total mass or volume of water it can hold, but by the mass in kg of water required to raise its level by one metre, similarly, the capacitance of a capacitor is defined as *“the amount of charge required to create a unit p.d. between its plates.”*

Suppose we give Q coulomb of charge to one of the two plate of capacitor and if a p.d. of V volts is established between the two, then its capacitance is

$$C = \frac{Q}{V} = \frac{\text{charge}}{\text{potential difference}}$$

Hence, capacitance is the *charge required per unit potential difference*.

By definition, the unit of capacitance is coulomb/volt which is also called *farad* (in honour of Michael Faraday)

∴

$$1 \text{ farad} = 1 \text{ coulomb/volt}$$

One farad is defined as *the capacitance of a capacitor which requires a charge of one coulomb to establish a p.d. of one volt between its plates*.

One farad is actually too large for practical purposes. Hence, much smaller units like microfarad (μF), nanofarad (nF) and micro-microfarad ($\mu\mu\text{F}$) or picofarad (pF) are generally employed.

$$1 \mu\text{F} = 10^{-6} \text{ F}; 1 \text{ nF} = 10^{-9} \text{ F}; 1 \mu\mu\text{F} \text{ or } \text{pF} = 10^{-12} \text{ F}$$

Incidentally, capacitance is that property of a capacitor which delays and change of voltage across it.

5.3. Capacitance of an Isolated Sphere

Consider a charged sphere of radius r metres having a charge of Q coulomb placed in a medium



A capacitor stores electricity

of relative permittivity ϵ_r , as shown in Fig. 5.2.

It has been proved in Art 4.13 that the free surface potential V of such a sphere with respect to infinity (in practice, earth) is given by

$$V = \frac{Q}{4\pi\epsilon_0\epsilon_r r} \quad \therefore \frac{Q}{V} = 4\pi\epsilon_0\epsilon_r r$$

By definition, $Q/V = \text{capacitance } C$

$$\therefore \begin{aligned} &= 4\pi\epsilon_0\epsilon_r r \text{ F} && \text{— in a medium} \\ &= 4\pi\epsilon_0 r \text{ F} && \text{— in air} \end{aligned}$$

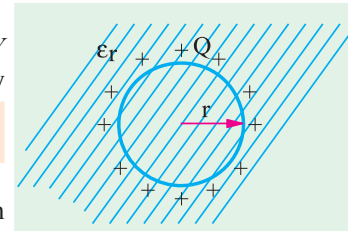

Fig. 5.2

Note : It is sometimes felt surprising that an isolated sphere can act as a capacitor because, at first sight, it appears to have one plate only. The question arises as to which is the second surface. But if we remember that the surface potential V is with reference to infinity (actually earth) then it is obvious that the other surface is earth. The capacitance $4\pi\epsilon_0 r$ exists between the surface of the sphere and earth.

5.4. Spherical Capacitor

(a) When outer sphere is earthed

Consider a spherical capacitor consisting of two concentric spheres of radii ' a ' and ' b ' metres as shown in Fig. 5.3. Suppose, the inner sphere is given a charge of $+Q$ coulombs. It will induce a charge of $-Q$ coulombs on the inner surfaces which will go to earth. If the dielectric medium between the two spheres has a relative permittivity of ϵ_r , then the free surface potential of the inner sphere due to its own charge $Q/4\pi\epsilon_0\epsilon_r a$ volts. The potential of the inner sphere due to $-Q$ charge on the outer sphere is $-Q/4\pi\epsilon_0\epsilon_r b$ (remembering that potential anywhere inside a sphere is the same as that its surface).

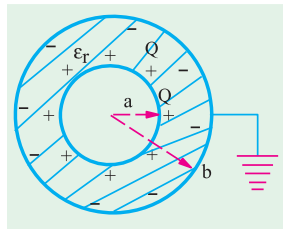

Fig. 5.3

\therefore Total potential difference between two surfaces is

$$\begin{aligned} V &= \frac{Q}{4\pi\epsilon_0\epsilon_r a} - \frac{Q}{4\pi\epsilon_0\epsilon_r b} \\ &= \frac{Q}{4\pi\epsilon_0\epsilon_r} \left(\frac{1}{a} - \frac{1}{b} \right) = \frac{Q}{4\pi\epsilon_0\epsilon_r} \left(\frac{b-a}{ab} \right) \\ \frac{Q}{V} &= \frac{4\pi\epsilon_0\epsilon_r ab}{b-a} \quad \therefore C = 4\pi\epsilon_0\epsilon_r \frac{ab}{b-a} \text{ F} \end{aligned}$$

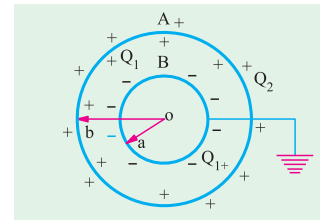

Fig. 5.4

(b) When inner sphere is earthed

Such a capacitor is shown in Fig. 5.4. If a charge of $+Q$ coulombs is given to the outer sphere A , it will distribute itself over both its inner and outer surfaces. Some charge Q_2 coulomb will remain on the outer surface of A because it is surrounded by earth all around. Also, some charge $+Q_1$ coulombs will shift to its inner side because there is an earthed sphere B inside A .

Obviously, $Q = Q_1 + Q_2$

The inner charge $+Q_1$ coulomb on A induces $-Q_1$ coulomb on B but the other induced charge of $+Q_1$ coulomb goes to earth.

Now, there are two capacitors connected in parallel :

(i) One capacitor consists of the inner surface of A and the outer surface of B . Its capacitance, as found earlier, is

$$C_1 = 4\pi\epsilon_0\epsilon_r \frac{ab}{b-a}$$

(ii) The second capacitor consists of outer surfaces of B and earth. Its capacitance is $C_2 = 4\pi\epsilon_0 b$ –if surrounding medium is air. Total capacitance $C = C_1 + C_2$.

5.5. Parallel-plate Capacitor

(i) Uniform Dielectric-Medium

A parallel-plate capacitor consisting of two plates M and N each of area A m² separated by a thickness d metres of a medium of relative permittivity ϵ_r is shown in Fig. 5.5. If a charge of $+Q$ coulomb is given to plate M , then flux passing through the medium is $\psi = Q$ coulomb. Flux density in the medium is

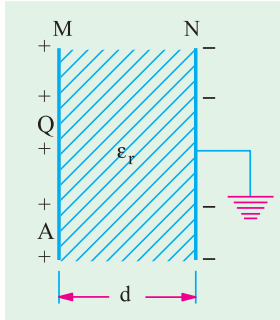

Fig. 5.5

$$D = \frac{\Psi}{A} = \frac{Q}{A}$$

Electric intensity $E = V/d$ and
 $D = \epsilon E$

$$\text{or} \quad \frac{Q}{A} = \epsilon \frac{V}{d} \quad \therefore \frac{Q}{V} = \frac{\epsilon A}{d}$$

$$\therefore C = \frac{\epsilon_0 \epsilon_r A}{d} \text{ farad} \quad \text{— in a medium} \quad \dots(i)$$

$$= \frac{\epsilon_0 A}{d} \text{ farad} \quad \text{— with air as medium}$$

(ii) Medium Partly Air

As shown in Fig. 5.6, the medium consists partly of air and partly of parallel-sided dielectric slab of thickness t and relative permittivity ϵ_r . The electric flux density $D = Q/A$ is the same in both media. But electric intensities are different.

$$E_1 = \frac{D}{\epsilon_0 \epsilon_r} \quad \dots \text{ in the medium}$$

$$E_2 = \frac{D}{\epsilon_0} \quad \dots \text{ in air}$$

$$\begin{aligned} \text{p.d. between plates, } V &= E_1 \cdot t + E_2 (d-t) \\ &= \frac{D}{\epsilon_0 \epsilon_r} t + \frac{D}{\epsilon_0} (d-t) = \frac{D}{\epsilon_0} \left(\frac{t}{\epsilon_r} + d-t \right) \\ &= \frac{Q}{\epsilon_0 A} [d - (t - t/\epsilon_r)] \end{aligned}$$

$$\text{or} \quad \frac{Q}{V} = \frac{\epsilon_0 A}{[d - (t - t/\epsilon_r)]} \quad \text{or} \quad C = \frac{\epsilon_0 A}{[d - (t - t/\epsilon_r)]} \quad \dots(ii)$$

If the medium were totally air, then capacitance would have been

$$C = \epsilon_0 A/d$$

From (ii) and (iii), it is obvious that when a dielectric slab of thickness t and relative permittivity ϵ_r is introduced between the plates of an air capacitor, then its capacitance increases because as seen from (ii), the denominator decreases. The distance between the plates is effectively reduces by $(t - t/\epsilon_r)$. To bring the capacitance back to its original value, the capacitor plates will have to be further separated by that much distance in air. Hence, the new separation between the two plates would be

$$= [d + (t - t/\epsilon_r)]$$

The expression given in (i) above can be written as $C = \frac{\epsilon_0 A}{d/\epsilon_r}$

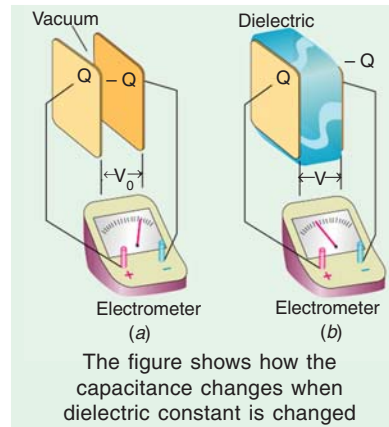

If the space between the plates is filled with slabs of different thickness and relative permittivities, then the above expression can be generalized into $C = \frac{\epsilon_0 A}{\sum d/\epsilon_r}$

The capacitance of the capacitor shown in Fig. 5.7 can be written as

$$C = \frac{\epsilon_0 A}{\left(\frac{d_1}{\epsilon_{r1}} + \frac{d_2}{\epsilon_{r2}} + \frac{d_3}{\epsilon_{r3}}\right)}$$

(iii) Composite Medium

The above expression may be derived independently as given under :

If V is the total potential difference across the capacitor plates and V_1, V_2, V_3 , the potential differences across the three dielectric slabs, then

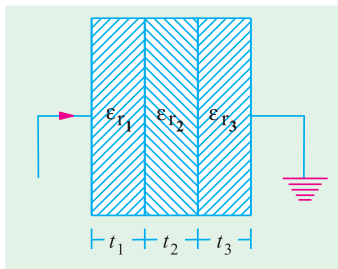

Fig. 5.7

$$\begin{aligned} V &= V_1 + V_2 + V_3 = E_1 t_1 + E_2 t_2 + E_3 t_3 \\ &= \frac{D}{\epsilon_0 \epsilon_{r1}} \cdot t_1 + \frac{D}{\epsilon_0 \epsilon_{r2}} \cdot t_2 + \frac{D}{\epsilon_0 \epsilon_{r3}} \cdot t_3 \\ &= \frac{D}{\epsilon_0} \left(\frac{t_1}{\epsilon_{r1}} + \frac{t_2}{\epsilon_{r2}} + \frac{t_3}{\epsilon_{r3}} \right) = \frac{Q}{\epsilon_0 A} \left(\frac{t_1}{\epsilon_{r1}} + \frac{t_2}{\epsilon_{r2}} + \frac{t_3}{\epsilon_{r3}} \right) \end{aligned}$$

$$\therefore C = \frac{Q}{V} = \frac{\epsilon_0 A}{\left(\frac{t_1}{\epsilon_{r1}} + \frac{t_2}{\epsilon_{r2}} + \frac{t_3}{\epsilon_{r3}}\right)}$$

5.6. Special Cases of Parallel-plate Capacitor

Consider the cases illustrated in Fig. 5.8.

(i) As shown in Fig. 5.8 (a), the dielectric is of thickness d but occupies only a part of the area. This arrangement is equal to two capacitors in parallel. Their capacitances are

$$C_1 = \frac{\epsilon_0 A_1}{d} \quad \text{and} \quad C_2 = \frac{\epsilon_0 \epsilon_r A_2}{d}$$

Total capacitance of the parallel-plate capacitor is

$$C = C_1 + C_2 = \frac{\epsilon_0 A_1}{d} + \frac{\epsilon_0 \epsilon_r A_2}{d}$$

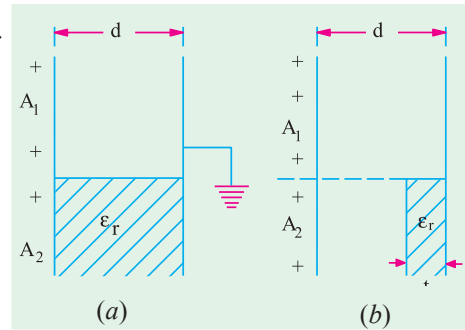

Fig. 5.8

(ii) The arrangement shown in Fig. 5.8 (b) consists of two capacitors connected in parallel.

(a) one capacitor having plate area A_1 and air as dielectric. Its capacitance is $C_1 = \frac{\epsilon_0 A_1}{d}$

(b) the other capacitor has dielectric partly air and partly some other medium. Its capacitance is [Art 5.5 (ii)]. $C_2 = \frac{\epsilon_0 A_2}{[d - (t - t/\epsilon_r)]}$. Total capacitance is $C = C_1 + C_2$

5.7. Multiple and Variable Capacitors

Multiple capacitors are shown in Fig. 5.9 and Fig. 5.10.

The arrangement of Fig. 5.9. is equivalent to two capacitors joined in parallel. Hence, its capacitance is double that of a single capacitor. Similarly, the arrangement of Fig. 5.10 has four times the capacitance of single capacitor.

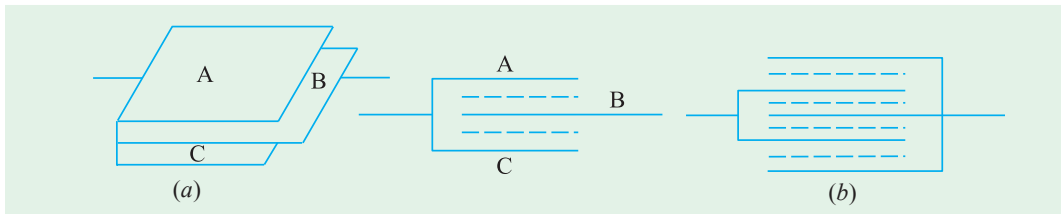

Fig. 5.9

Fig. 5.10

If one set of plates is fixed and the other is capable of rotation, then capacitance of such a multiplate capacitor can be varied. Such variable-capacitance air capacitors are widely used in radio work (Fig. 5.11). The set of fixed plates F is insulated from the other set R which can be rotated by turning the knob K . The common area between the two sets is varied by rotating K , hence the capacitance between the two is altered. Minimum capacitance is obtained when R is completely rotated out of F and maximum when R is completely rotated in *i.e.* when the two sets of plates completely overlap each other.

The capacitance of such a capacitor is

$$= \frac{(n-1) \cdot \epsilon_0 \epsilon_r A}{d}$$

where n is the number of plates which means that $(n-1)$ is the number of capacitors.

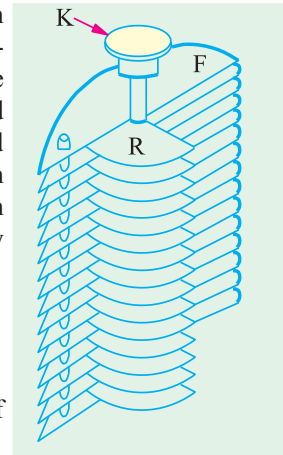

Fig. 5.11

Example 5.1. The voltage applied across a capacitor having a capacitance of $10 \mu F$ is varied thus :

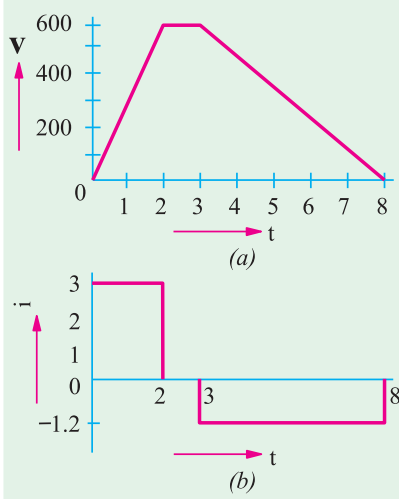

Fig. 5.12

The p.d. is increased uniformly from 0 to 600 V in seconds. It is then maintained constant at 600 V for 1 second and subsequently decreased uniformly to zero in five seconds. Plot a graph showing the variation of current during these 8 seconds. Calculate (a) the charge (b) the energy stored in the capacitor when the terminal voltage is 600.

(Principles of Elect. Engg.-I, Jadavpur Univ.)

Solution. The variation of voltage across the capacitor is as shown in Fig. 5.12 (a).

The charging current is given by

$$i = \frac{dq}{dt} = \frac{d}{dt} (Cv) = C \cdot \frac{dv}{dt}$$

Charging current during the first stage

$$= 10 \times 10^{-6} \times (600/2) = 3 \times 10^{-3} \text{ A} = 3 \text{ mA}$$

Charging current during the second stage is zero because $dv/dt = 0$ as the voltage remains constant.

Charging current through the third stage

$$= 10 \times 10^{-6} \times \left(\frac{0-600}{5} \right) = -1.2 \times 10^{-3} \text{ A} = -1.2 \text{ mA}$$

The waveform of the charging current or capacitor current is shown in Fig. 5.12 (b).

(a) Charge when a steady voltage of 600 V is applied is $= 600 \times 10 \times 10^{-6} = 6 \times 10^{-3} \text{ C}$

(b) Energy stored $= \frac{1}{2} C V^2 = \frac{1}{2} \times 10^{-5} \times 600^2 = 1.8 \text{ J}$

Example 5.2. A voltage of V is applied to the inner sphere of a spherical capacitor, whereas the outer sphere is earthed. The inner sphere has a radius of a and the outer one of b . If b is fixed and a may be varied, prove that the maximum stress in the dielectric cannot be reduced below a value of $4 V/b$.

Solution. As seen from Art. 5.4,

$$V = \frac{Q}{4\pi\epsilon_0\epsilon_r}\left(\frac{1}{a} - \frac{1}{b}\right) \quad \dots(i)$$

As per Art. 4.15, the value of electric intensity at any radius x between the two spheres is given by $E = \frac{Q}{4\pi\epsilon_0\epsilon_r x^2}$ or $Q = 4\pi\epsilon_0\epsilon_r x^2 E$

Substituting this value in (i) above, we get

$$V = \frac{4\pi\epsilon_0\epsilon_r x^2 E}{4\pi\epsilon_0\epsilon_r} \left(\frac{1}{a} - \frac{1}{b}\right) \quad \text{or} \quad E = \frac{V}{(1/a - 1/b)x^2}$$

As per Art. 5.9, the maximum value of E occurs as the surface of inner sphere *i.e.* when $x = a$

For E to be maximum or minimum, $dE/da = 0$.

$$\therefore \frac{d}{da} \left(\frac{1}{a} - \frac{1}{b}\right) a^2 = 0 \quad \text{or} \quad \frac{d}{da} (a - a^2/b) = 0$$

$$\text{or} \quad 1 - 2a/b = 0 \quad \text{or} \quad a = b/2$$

$$\text{Now,} \quad E = \frac{V}{(1/a - 1/b)x^2} \quad \therefore E_{\max} = \frac{V}{(1/a - 1/b)a^2} = \frac{V}{(a - a^2/b)}$$

$$\text{Since, } a = b/2 \quad \therefore E_{\max} = \frac{V}{(b/2 - b^2/4b)} = \frac{4bV}{2b^2 - b^2} = \frac{4bV}{b^2} = \frac{4V}{b}$$

Example 5.3. A capacitor consists of two similar square aluminium plates, each $10 \text{ cm} \times 10 \text{ cm}$ mounted parallel and opposite to each other. What is their capacitance in μF when distance between them is 1 cm and the dielectric is air? If the capacitor is given a charge of $500 \mu\text{C}$, what will be the difference of potential between plates? How will this be affected if the space between the plates is filled with wax which has a relative permittivity of 4?

Solution.

$$C = \epsilon_0 A/d \text{ farad}$$

Here

$$\epsilon_0 = 8.854 \times 10^{-12} \text{ F/m}; \quad A = 10 \times 10 = 100 \text{ cm}^2 = 10^{-2} \text{ m}^2$$

$$d = 1 \text{ cm} = 10^{-2} \text{ m}$$

$$\therefore C = \frac{8.854 \times 10^{-12} \times 10^{-2}}{10^{-2}} = 8.854 \times 10^{-12} \text{ F} = \mathbf{8.854 \mu\text{F}}$$

$$\text{Now} \quad C = \frac{Q}{V} \quad \therefore V = \frac{Q}{C} \quad \text{or} \quad V = \frac{500 \times 10^{-12} \text{ C}}{8.854 \times 10^{-12} \text{ F}} = \mathbf{56.5 \text{ volts.}}$$

When wax is introduced, their capacitance is increased four times because

$$C = \epsilon_0 \epsilon_r A/d \quad \text{F} = 4 \times 8.854 = 35.4 \mu\text{F}$$

The p.d. will obviously decrease to one fourth value because charge remains constant.

$$\therefore V = 56.5/4 = \mathbf{14.1 \text{ volts.}}$$

Example 5.4. The capacitance of a capacitor formed by two parallel metal plates each 200 cm^2 in area separated by a dielectric 4 mm thick is $0.0004 \text{ microfarads}$. A p.d. of $20,000 \text{ V}$ is applied. Calculate (a) the total charge on the plates (b) the potential gradient in V/m (c) relative permittivity of the dielectric (d) the electric flux density. **(Elect. Engg. I Osmania Univ.)**

Solution.

$$C = 4 \times 10^4 \mu\text{F}; \quad V = 2 \times 10^4 \text{ V}$$

$$(a) \quad \therefore \text{Total charge} \quad Q = CV = 4 \times 10^4 \times 2 \times 10^4 \mu\text{C} = 8 \mu\text{C} = \mathbf{8 \times 10^6 \text{ C}}$$

$$(b) \quad \text{Potential gradient} \quad = \frac{dV}{dx} = \frac{2 \times 10^4}{4 \times 10^{-3}} = \mathbf{5 \times 10^6 \text{ V/m}}$$

$$(c) \quad D = Q/A = 8 \times 10^6 / 200 \times 10^{-4} = \mathbf{4 \times 10^4 \text{ C/m}^2}$$

$$(d) \quad E = 5 \times 10^6 \text{ V/m}$$

$$\text{Since } D = \epsilon_0 \epsilon_r E \quad \therefore \epsilon_r = \frac{D}{\epsilon_0 \times E} = \frac{4 \times 10^4}{8.854 \times 10^{-12} \times 5 \times 10^6} = \mathbf{9}$$

Example 5.5. A parallel plate capacitor has 3 dielectrics with relative permittivities of 5.5, 2.2 and 1.5 respectively. The area of each plate is 100 cm^2 and thickness of each dielectric 1 mm. Calculate the stored charge in the capacitor when a potential difference of 5,000 V is applied across the composite capacitor so formed. Calculate the potential gradient developed in each dielectric of the capacitor. (Elect. Engg. A.M.Ae.S.I.)

Solution. As seen from Art. 5.5,

$$C = \frac{\epsilon_0 A}{\left(\frac{d_1}{\epsilon_{r1}} + \frac{d_2}{\epsilon_{r2}} + \frac{d_3}{\epsilon_{r3}}\right)} = \frac{8.854 \times 10^{-12} \times (100 \times 10^{-4})}{\left(\frac{10^{-3}}{5.5} + \frac{10^{-3}}{2.2} + \frac{10^{-3}}{1.5}\right)} = \frac{8.854 \times 10^{-14}}{10^{-3} \times 0.303} = 292 \text{ pF}$$

$$Q = CV = 292 \times 10^{-12} \times 5000 = 146 \times 10^{-8} \text{ coulomb}$$

$$D = Q/A = 146 \times 10^{-8} / (100 \times 10^{-4}) = 146 \times 10^{-6} \text{ C/m}^2$$

$$g_1 = E_1 = D/\epsilon_0 \epsilon_{r1} = 146 \times 10^{-6} / 8.854 \times 10^{-12} \times 5.5 = 3 \times 10^6 \text{ V/m}$$

$$g_2 = E_2 = D/\epsilon_0 \epsilon_{r2} = 7.5 \times 10^6 \text{ V/m}; g_3 = D/\epsilon_0 \epsilon_{r3} = 11 \times 10^6 \text{ V/m}$$

Example 5.6. An air capacitor has two parallel plates 10 cm^2 in area and 0.5 cm apart. When a dielectric slab of area 10 cm^2 and thickness 0.4 cm was inserted between the plates, one of the plates has to be moved by 0.4 cm to restore the capacitance. What is the dielectric constant of the slab? (Elect. Technology, Hyderabad Univ. 1992)

Solution. The capacitance in the first case is

$$C_a = \frac{\epsilon_0 A}{d} = \frac{\epsilon_0 \times 10 \times 10^{-4}}{0.5 \times 10^{-2}} = \frac{\epsilon_0}{5}$$

The capacitor, as it becomes in the second case, is shown in Fig. 5.13. The capacitance is

$$C_m = \frac{\epsilon_0 A}{\Sigma d / \epsilon_r} = \frac{\epsilon_0 \times 10^{-3}}{\left(\frac{0.5 \times 10^{-3}}{\epsilon_r}\right) + \left(\frac{5}{\epsilon_r} + 4\right)}$$

$$\text{Since, } C_a = C_m \therefore \frac{\epsilon_0}{5} = \frac{\epsilon_0}{(5/\epsilon_r + 4)} \therefore \epsilon_r = 5$$

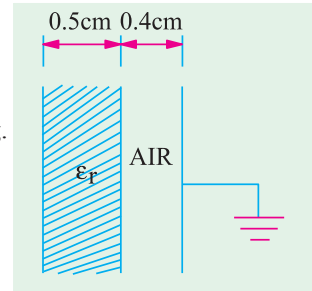

Fig. 5.13

Note. We may use the relation derived in Art. 5.5 (ii)

$$\text{Separation} = (t - t/\epsilon_1) \therefore 0.4 = (0.5 - 0.5/\epsilon_r) \text{ or } \epsilon_r = 5$$

Example 5.7. A parallel plate capacitor of area, A , and plate separation, d , has a voltage, V_0 , applied by a battery. The battery is then disconnected and a dielectric slab of permittivity ϵ_1 and thickness, d_1 , ($d_1 < d$) is inserted. (a) Find the new voltage V_1 across the capacitor; (b) Find the capacitance C_0 before and its value C_1 after the slab is introduced. (c) Find the ratio V_1/V_0 and the ratio C_1/C_0 when $d_1 = d/2$ and $\epsilon_1 = 4 \epsilon_0$.

(Electromagnetic Fields and Waves AMIETE (New Scheme) June 1990)

Solution. (b)

$$C_0 = \frac{\epsilon_0 A}{d}; C_1 = \frac{A}{\left(\frac{(d - d_1)}{\epsilon_0} + \frac{d_1}{\epsilon_1}\right)}$$

$$\text{Since } d_1 = d/2 \text{ and } \epsilon_1 = 4 \epsilon_0 \therefore C_1 = \frac{A}{\left(\frac{d}{2\epsilon_0} + \frac{d}{2 \times 4 \epsilon_0}\right)} = \frac{8 \epsilon_0 A}{5d}$$

(a) Since the capacitor charge remains the same

$$Q = C_0 V_0 = C_1 V_1 \therefore V_1 = V_0 \frac{C_0}{C_1} = V_0 \times \frac{\epsilon_0 A}{d} \times \frac{5d}{8 \epsilon_0 A} = \frac{5V_0}{8}$$

(c) As seen from above, $V_1 = V_0/8$; $C_1/C_0 = \frac{8\epsilon_0 A}{5d} \times \frac{d}{\epsilon_0 A} = \frac{5}{8}$

Tutorial Problems No. 5.1

1. Two parallel plate capacitors have plates of an equal area, dielectrics of relative permittivities ϵ_{r1} and ϵ_{r2} and plate spacing of d_1 and d_2 . Find the ratio of their capacitances if $\epsilon_{r1}/\epsilon_{r2} = 2$ and $d_1/d_2 = 0.25$.

[$C_1/C_2 = 8$]

2. A capacitor is made of two plates with an area of 11 cm^2 which are separated by a mica sheet 2 mm thick. If for mica $\epsilon_r = 6$, find its capacitance. If, now, one plate of the capacitor is moved further to give an air gap 0.5 mm wide between the plates and mica, find the change in capacitance.

[29.19 pF, 11.6 pF]

3. A parallel-plate capacitor is made of two plane circular plates separated by d cm of air. When a parallel-faced plane sheet of glass 2 mm thick is placed between the plates, the capacitance of the system is increased by 50% of its initial value. What is the distance between the plates if the dielectric constant of the glass is 6?

[$0.5 \times 10^{-3} \text{ m}$]

4. A p.d. of 10 kV is applied to the terminals of a capacitor consisting of two circular plates, each having an area of 100 cm^2 separated by a dielectric 1 mm thick. If the capacitance is $3 \times 10^{-4} \mu\text{F}$, calculate
(a) the total electric flux in coulomb
(b) the electric flux density and
(c) the relative permittivity of the dielectric.

[(a) $3 \times 10^{-6} \text{ C}$ (b) $3 \times 10^{-4} \mu\text{C/m}^2$ (c) 3.39]

5. Two slabs of material of dielectric strength 4 and 6 and of thickness 2 mm and 5 mm respectively are inserted between the plates of a parallel-plate capacitor. Find by how much the distance between the plates should be changed so as to restore the potential of the capacitor to its original value.

[5.67 mm]

6. The oil dielectric to be used in a parallel-plate capacitor has a relative permittivity of 2.3 and the maximum working potential gradient in the oil is not to exceed 10^6 V/m . Calculate the approximate plate area required for a capacitance of $0.0003 \mu\text{F}$, the maximum working voltage being 10,000 V.

[$147 \times 10^3 \text{ m}^2$]

7. A capacitor consist of two metal plates, each 10 cm square placed parallel and 3 mm apart. The space between the plates is occupied by a plate of insulating material 3 mm thick. The capacitor is charged to 300 V.

(a) the metal plates are isolated from the 300 V supply and the insulating plate is removed. What is expected to happen to the voltage between the plates?

(b) if the metal plates are moved to a distance of 6 mm apart, what is the further effect on the voltage between them. Assume throughout that the insulation is perfect.

[300 ϵ_r ; 600 ϵ_r ; where ϵ_r is the relative permittivity of the insulating material]

8. A parallel-plate capacitor has an effecting plate area of 100 cm^2 (each plate) separated by a dielectric 0.5 mm thick. Its capacitance is $442 \mu\text{F}$ and it is raised to a potential differences of 10 kV. Calculate from first principles

(a) potential gradient in the dielectric (b) electric flux density in the dielectric

(c) the relative permittivity of the dielectric material.

[(a) 20 kV/mm (b) $442 \mu\text{C/m}^2$ (c) 2.5]

9. A parallel-plate capacitor with fixed dimensions has air as dielectric. It is connected to supply of p.d. V volts and then isolated. The air is then replaced by a dielectric medium of relative permittivity 6. Calculate the change in magnitude of each of the following quantities.

(a) the capacitance (b) the charge (c) the p.d. between the plates

(d) the displacement in the dielectric (e) the potential gradient in the dielectric.

[(a) 6 : 1 increase (b) no change (c) 6 : 1 decrease (d) no change (e) 6 : 1 decrease]

5.8. Cylindrical Capacitor

A single-core cable or cylindrical capacitor consisting two co-axial cylinders of radii a and b metres, is shown in Fig. 5.14. Let the charge per metre length of the cable on the outer surface of the inner cylinder be $+Q$ coulomb and on the inner surface of the outer cylinder be $-Q$ coulomb. For all practical purposes, the charge $+Q$ coulomb/metre on the surface of the inner cylinder can be supposed to be located along its axis. Let ϵ_r be the relative permittivity of the medium between the two cylinders. The outer cylinder is earthed.

Now, let us find the value of electric intensity at any point distant x metres from the axis of the inner cylinder. As shown in Fig. 5.15, consider an imaginary co-axial cylinder of radius x metres and length one metre between the two given cylinders. The electric field between the two cylinders is radial as shown. Total flux coming out radially from the curved surface of this imaginary cylinder is Q coulomb. Area of the curved surface $= 2\pi x \times 1 = 2\pi x$ m².

Hence, the value of electric flux density on the surface of the imaginary cylinder is

$$D = \frac{\text{flux in coulomb}}{\text{area in metre}^2} = \frac{\Psi}{A} = \frac{Q}{A} \text{ C/m}^2 \therefore D = \frac{Q}{2\pi x} \text{ C/m}^2$$

The value of electric intensity is

$$E = \frac{D}{\epsilon_0 \epsilon_r} \quad \text{or} \quad E = \frac{Q}{2\pi \epsilon_0 \epsilon_r x} \text{ V/m}$$

Now, $dV = -E dx$

$$\begin{aligned} \text{or} \quad V &= \int_b^a -E \cdot dx = \int_b^a -\frac{Q dx}{2\pi \epsilon_0 \epsilon_r x} \\ &= \frac{-Q}{2\pi \epsilon_0 \epsilon_r} \int_b^a \frac{dx}{x} = \frac{-Q}{2\pi \epsilon_0 \epsilon_r} \left| \log_e x \right|_b^a \\ &= \frac{-Q}{2\pi \epsilon_0 \epsilon_r} (\log_e a - \log_e b) = \frac{-Q}{2\pi \epsilon_0 \epsilon_r} \log_e \left(\frac{a}{b} \right) = \frac{Q}{2\pi \epsilon_0 \epsilon_r} \log_e \left(\frac{b}{a} \right) \\ \frac{Q}{V} &= \frac{2\pi \epsilon_0 \epsilon_r}{\log_e \left(\frac{b}{a} \right)} \therefore C = \frac{2\pi \epsilon_0 \epsilon_r}{2.3 \log_{10} \left(\frac{b}{a} \right)} \text{ F/m} \left(\log_e \left(\frac{b}{a} \right) = 2.3 \log_{10} \left(\frac{b}{a} \right) \right) \end{aligned}$$

The capacitance of l metre length of this cable is $C = \frac{2\pi \epsilon_0 \epsilon_r l}{2.3 \log_{10} \left(\frac{b}{a} \right)} \text{ F}$

In case the capacitor has compound dielectric, the relation becomes

$$C = \frac{2\pi \epsilon_0 l}{\sum \log_e \left(\frac{b}{a} \right) / \epsilon_r} \text{ F}$$

The capacitance of 1 km length of the cable in μF can be found by putting $l = 1$ km in the above expression.

$$C = \frac{2\pi \times 8.854 \times 10^{-12} \times \epsilon_r \times 1000}{2.3 \log_{10} \left(\frac{b}{a} \right)} \text{ F/km} = \frac{0.024 \epsilon_r}{\log_{10} \left(\frac{b}{a} \right)} \mu\text{F/km}$$

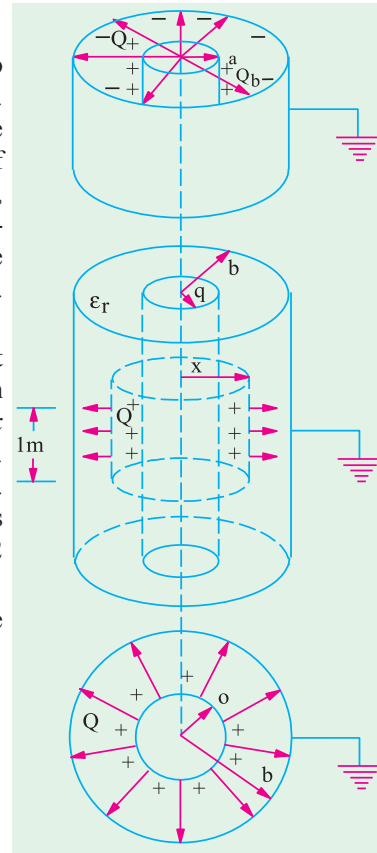

Fig. 5.14

5.9. Potential Gradient in a Cylindrical Capacitor

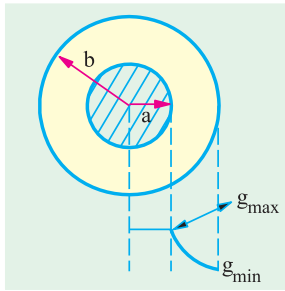

Fig. 5.15

It is seen from Art. 5.8 that in a cable capacitor

$$E = \frac{Q}{2\pi\epsilon_0\epsilon_r x} \text{ V/m}$$

where x is the distance from cylinder axis to the point under consideration.

Now $E = g \therefore g = \frac{Q}{2\pi\epsilon_0\epsilon_r x} \text{ V/m} \dots (i)$

From Art. 5.8, we find that $V = \frac{Q}{2\pi\epsilon_0\epsilon_r} \log_e \left(\frac{b}{a}\right)$ or $Q = \frac{2\pi\epsilon_0\epsilon_r V}{\log_e \left(\frac{b}{a}\right)}$

Substituting this value of Q in (i) above, we get

$$g = \frac{2\pi\epsilon_0\epsilon_r V}{\log_e \left(\frac{b}{a}\right) \times 2\pi\epsilon_0\epsilon_r x} \text{ V/m} \text{ or } g = \frac{V}{x \log_e \left(\frac{b}{a}\right)} \text{ V/m} \text{ or } g = \frac{V}{2.3 x \log_{10} \left(\frac{b}{a}\right)} \text{ volt/metre}$$

Obviously, potential gradient varies inversely as x .

Minimum value of $x = a$, hence maximum value of potential gradient is

$$g_{max} = \frac{V}{2.3 a \log_{10} \left(\frac{b}{a}\right)} \text{ V/m} \dots (ii)$$

Similarly,

$$g_{max} = \frac{V}{2.3 b \log_{10} \left(\frac{b}{a}\right)} \text{ V/m}$$

Note. The above relation may be used to obtain most economical dimension while designing a cable. As seen, greater the value of permissible maximum stress E_{max} , smaller the cable may be for given value of V . However, E_{max} is dependent on the dielectric strength of the insulating material used.

If V and E_{max} are fixed, then Eq. (ii) above may be written as

$$E_{max} = \frac{V}{a \log_e \left(\frac{b}{a}\right)} \text{ or } a \log_e \left(\frac{b}{a}\right) = \frac{V}{E_{max}} \therefore \frac{b}{a} = e^{k/a} \text{ or } b = a e^{k/a}$$

For most economical cable $db/da = 0$

$$\therefore \frac{db}{da} = 0 = e^{k/a} + a(-k/a^2)e^{k/a} \text{ or } a = k = V/E_{max} \text{ and } b = ae = 2.718 a$$

Example 5.8. A cable is 300 km long and has a conductor of 0.5 cm in diameter with an insulation covering of 0.4 cm thickness. Calculate the capacitance of the cable if relative permittivity of insulation is 4.5. (Elect. Engg. A.M.Ae. S.I.)

Solution. Capacitance of a cable is $C = \frac{0.024 \epsilon_r}{\log_{10} \left(\frac{b}{a}\right)} \mu \text{ F/km}$

Here, $a = 0.5/2 = 0.25 \text{ cm}$; $b = 0.25 + 0.4 = 0.65 \text{ cm}$; $b/a = 0.65/0.25 = 2.6$; $\log_{10}^{2.6} = 0.415$

$$\therefore C = \frac{0.024 \times 4.5}{0.415} = 0.26$$

Total capacitance for 300 km is $= 300 \times 0.26 = 78 \mu \text{ F}$.

Example 5.9. In a concentric cable capacitor, the diameters of the inner and outer cylinders are 3 and 10 mm respectively. If ϵ_r for insulation is 3, find its capacitance per metre.

A p.d. of 600 volts is applied between the two conductors. Calculate the values of the electric force and electric flux density : (a) at the surface of inner conductor (b) at the inner surface of outer conductor.

Solution. $a = 1.5 \text{ mm}$; $b = 5 \text{ mm}$; $\therefore b/a = 5/1.5 = 10/3$; $\log_{10}\left(\frac{10}{3}\right) = 0.523$

$$C = \frac{2\pi\epsilon_0\epsilon_r l}{2.3 \log_{10}\left(\frac{b}{a}\right)} = \frac{2\pi \times 8.854 \times 10^{-12} \times 3 \times 1}{2.3 \times 0.523} = 138.8 \times 10^{-12} \text{ F} = \mathbf{138.8 \text{ pF}}$$

(a) $D = Q/2\pi a$

Now $Q = CV = 138.8 \times 10^{-12} \times 600 = 8.33 \times 10^{-9} \text{ C}$

$$D = 8.33 \times 10^{-9} / 2\pi \times 1.5 \times 10^{-3} = \mathbf{8.835 \mu \text{ C/m}^2}$$

$$E = D/\epsilon_0\epsilon_r = \mathbf{332.6 \text{ V/m}}$$

(b) $D = \frac{8.33 \times 10^{-9}}{2\pi \times 5 \times 10^{-3}} \text{ C/m}^2 = \mathbf{2.65 \mu \text{ C/m}^2}$; $E = D/\epsilon_0\epsilon_r = \mathbf{99.82 \text{ V/m}}$.

Example 5.10. The radius of the copper core of a single-core rubber-insulated cable is 2.25 mm. Calculate the radius of the lead sheath which covers the rubber insulation and the cable capacitance per metre. A voltage of 10 kV may be applied between the core and the lead sheath with a safety factor of 3. The rubber insulation has a relative permittivity of 4 and breakdown field strength of $18 \times 10^6 \text{ V/m}$.

Solution. As shown in Art. 5.9, $g_{max} = \frac{V}{2.3 a \log_{10}\left(\frac{b}{a}\right)}$

Now, $g_{max} = E_{max} = 18 \times 10^6 \text{ V/m}$; $V = \text{breakdown voltage } x$

Safety factor = $10^4 \times 3 = 30,000 \text{ V}$

$$\therefore 18 \times 10^6 = \frac{30,000}{2.3 \times 2.25 \times 10^{-3} \times \log_{10}\left(\frac{b}{a}\right)} \therefore \frac{b}{a} = 2.1 \text{ or } b = 2.1 \times 2.25 = 4.72 \text{ mm}$$

$$C = \frac{2\pi\epsilon_0\epsilon_r l}{2.3 \log_{10}\left(\frac{b}{a}\right)} = \frac{2\pi \times 8.854 \times 10^{-12} \times 4 \times 1}{2.3 \log_{10}(2.1)} = \mathbf{3 \times 10^{-9} \text{ F}}$$

5.10. Capacitance Between Two Parallel Wires

This case is of practical importance in overhead transmission lines. The simplest system is 2-wire system (either *d.c.* or *a.c.*). In the case of *a.c.* system, if the transmission line is long and voltage high, the charging current drawn by the line due to the capacitance between conductors is appreciable and affects its performance considerably.

With reference to Fig. 5.16, let

d = distance between centres of the wires A and B

r = radius of each wire ($\leq d$)

Q = charge in coulomb/metre of each wire*

Now, let us consider electric intensity at any point P between conductors A and B .

Electric intensity at P^* due to charge $+Q$ coulomb/metre on A is

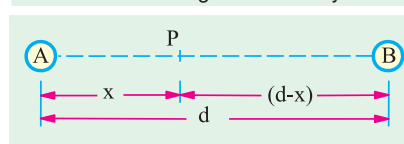
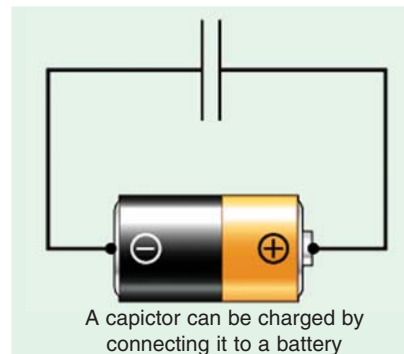

Fig. 5.16

* If charge on A is $+Q$, then on B will be $-Q$.

$$= \frac{Q}{2\pi\epsilon_0\epsilon_r x} \text{ V/m}$$

... towards B.

Electric intensity at P due to charge $-Q$ coulomb/metre on B is

$$= \frac{Q}{2\pi\epsilon_0\epsilon_r (d-x)} \text{ V/m}$$

... towards B.

$$\text{Total electric intensity at P, } E = \frac{Q}{2\pi\epsilon_0\epsilon_r} \left(\frac{1}{x} + \frac{1}{d-x} \right)$$

Hence, potential difference between the two wires is

$$V = \int_r^{d-r} E dx = \frac{Q}{2\pi\epsilon_0\epsilon_r} \int_r^{d-r} \left(\frac{1}{x} + \frac{1}{d-x} \right) dx$$

$$V = \frac{Q}{2\pi\epsilon_0\epsilon_r} \left[\log_e x - \log_e (d-x) \right]_r^{d-r} = \frac{Q}{\pi\epsilon_0\epsilon_r} \log_e \frac{d-r}{r}$$

$$\text{Now } C = Q/V \therefore C = \frac{\pi\epsilon_0\epsilon_r}{\log_e \frac{(d-r)}{r}} = \frac{\pi\epsilon_0\epsilon_r}{2.3 \log_{10} \frac{(d-r)}{r}} = \frac{\pi\epsilon_0\epsilon_r}{2.3 \log_{10} \left(\frac{d}{r} \right)} \text{ F/m (approx.)}$$

$$\text{The capacitance for a length of } l \text{ metres } C = \frac{\pi\epsilon_0\epsilon_r}{2.3 \log_{10} \left(\frac{d}{r} \right)} \text{ F}$$

The capacitance per kilometre is

$$C = \frac{\pi \times 8.854 \times 10^{-12} \times \epsilon_r \times 100 \times 10^6}{2.3 \log_{10} \left(\frac{d}{r} \right)} = \frac{0.0121 \epsilon_r}{\log_{10} \left(\frac{d}{r} \right)} \mu \text{ F/km}$$

Example 5.11. The conductors of a two-wire transmission line (4 km long) are spaced 45 cm between centre. If each conductor has a diameter of 1.5 cm, calculate the capacitance of the line.

Solution. Formula used $C = \frac{\pi\epsilon_0\epsilon_r}{2.3 \log_{10} \left(\frac{d}{r} \right)} \text{ F}$

$$\text{Here } l = 4000 \text{ metres ; } r = 1.5/2 \text{ cm ; } d = 45 \text{ cm ; } \epsilon_r = 1 \text{—for air } \therefore \frac{d}{r} = \frac{45 \times 2}{1.5} = 60$$

$$C = \frac{\pi \times 8.854 \times 10^{-12} \times 4000}{2.3 \log_{10} 60} = 0.0272 \times 10^{-6} \text{ F}$$

$$[\text{or } C = 4 \frac{0.0121}{\log_{10} 60} \text{ } 0.0272 \mu \text{F}]$$

5.11. Capacitors in Series

With reference of Fig. 5.17, let

$$C_1, C_2, C_3 = \text{Capacitances of three capacitors}$$

$$V_1, V_2, V_3 = \text{p.ds. across three capacitors.}$$

$$V = \text{applied voltage across combination}$$

$$C = \text{combined or equivalent or joining capacitance.}$$

In series combination, charge on all capacitors is the same but p.d. across each is different.

$$\begin{aligned} \therefore V &= V_1 + V_2 + V_3 \\ \text{or } \frac{Q}{C} &= \frac{Q}{C_1} + \frac{Q}{C_2} + \frac{Q}{C_3} \\ \text{or } \frac{1}{C} &= \frac{1}{C_1} + \frac{1}{C_2} + \frac{1}{C_3} \end{aligned}$$

For a changing applied voltage,

$$\frac{dV}{dt} = \frac{dV_1}{dt} + \frac{dV_2}{dt} + \frac{dV_3}{dt}$$

We can also find values of V_1 , V_2 and V_3 in terms of V . Now, $Q = C_1 V_1 = C_2 V_2 = C_3 V_3 = CV$

$$\text{where } C = \frac{C_1 C_2 C_3}{C_1 C_2 + C_2 C_3 + C_3 C_1} = \frac{C_1 C_2 C_3}{\Sigma C_1 C_2}$$

$$\therefore C_1 V_1 = CV \text{ or } V_1 = V \frac{C}{C_1} = V \frac{C_2 C_3}{\Sigma C_1 C_2}$$

$$\text{Similarly, } V_2 = V \cdot \frac{C_1 C_3}{\Sigma C_1 C_2} \text{ and } V_3 = V \cdot \frac{C_1 C_2}{\Sigma C_1 C_2}$$

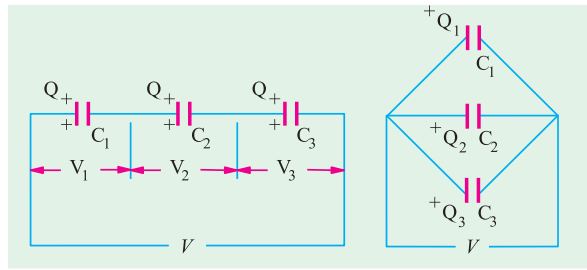

Fig. 5.17

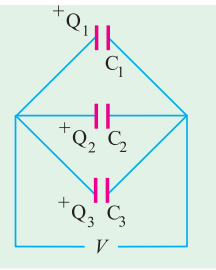

Fig. 5.18

5.12. Capacitors in Parallel

In this case, p.d. across each is the same but charge on each is different (Fig. 5.18).

$$\therefore Q = Q_1 + Q_2 + Q_3 \text{ or } CV = C_1 V + C_2 V + C_3 V \text{ or } C = C_1 + C_2 + C_3$$

For such a combination, dV/dt is the same for all capacitors.

Example 5.12. Find the C_{eq} of the circuit shown in Fig. 5.19. All capacitances are in μF .

(Basic Circuit Analysis Osmania Univ. Jan./Feb. 1992)

Solution. Capacitance between C and D = $4 + 1 \parallel 2 = 14/3 \mu F$.

Capacitance between A and B i.e. $C_{eq} = 3 + 2 \parallel 14/3 = 4.4 \mu F$

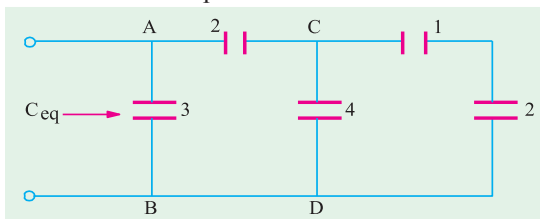

Fig. 5.19

Example 5.13. Two capacitors of a capacitance $4 \mu F$ and $2 \mu F$ respectively, are joined in series with a battery of e.m.f. $100 V$. The connections are broken and the like terminals of the capacitors are then joined. Find the final charge on each capacitor.

Solution. When joined in series, let V_1 and V_2 be the voltages across the capacitors. Then as charge across each is the same.

$$\therefore 4 \times V_1 = 2V_2 \quad \therefore V_2 = 2V_1 \quad \text{Also } V_1 + V_2 = 100$$

$$\therefore V_1 + 2V_1 = 100 \quad \therefore V_1 = 100/3 \text{ V} \quad \text{and } V_2 = 200/3 \text{ V}$$

$$\therefore Q_1 = Q_2 = (200/3) \times 2 = (400/3) \mu C$$

$$\therefore \text{Total charge on both capacitors} = 800/3 \mu C$$

When joined in parallel, a redistribution of charge takes place because both capacitors are reduced to a common potential V .

$$\text{Total charge} = 800/3 \mu C; \text{ total capacitance} = 4 + 2 = 6 \mu F$$

$$\therefore V = \frac{800}{3 \times 6} = \frac{400}{9} \text{ volts}$$

Hence

$$Q_1 = (400/9) \times 4 = 1600/9 = 178 \mu\text{C}$$

$$Q_2 = (400/9) \times 2 = 800/9 = 89 \mu\text{C (approx.)}$$

Example 5.14. Three capacitors A, B, C have capacitances 10, 50 and 25 μF respectively.

Calculate (i) charge on each when connected in parallel to a 250 V supply (ii) total capacitance and (iii) p.d. across each when connected in series. (Elect. Technology, Gwalior Univ.)

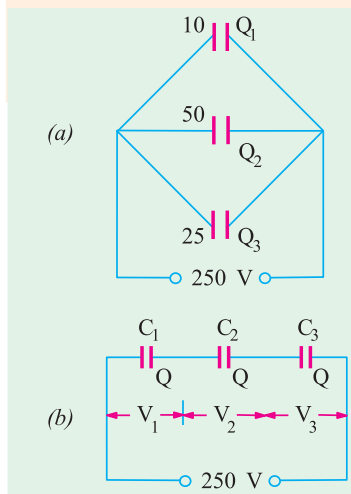

Fig. 5.20

Solution. (i) Parallel connection is shown in Fig. 5.20 (a). Each capacitor has a p.d. of 250 V across it.

$$Q_1 = C_1 V = 10 \times 250 = 2500 \mu\text{C}; Q_2 = 50 \times 250 = 12,500 \mu\text{C}$$

$$Q_3 = 25 \times 250 = 6,750 \mu\text{C}.$$

$$(ii) C = C_1 + C_2 + C_3 = 10 + 50 + 25 = 85 \mu\text{F}$$

(iii) Series connection is shown in Fig. 5.20 (b). Here charge on each capacitor is the same and is equal to that on the equivalent single capacitor.

$$1/C = 1/C_1 + 1/C_2 + 1/C_3; C = 25/4 \mu\text{F}$$

$$Q = CV = 25 \times 250/4 = 1562.5 \mu\text{C}$$

$$Q = C_1 V_1; V_1 = 1562.5/10 = 156.25 \text{ V}$$

$$V_2 = 1562.5/25 = 62.5 \text{ V}; V_3 = 1562.5/50 = 31.25 \text{ V}.$$

Example 5.15. Find the charges on capacitors in Fig. 5.21 and the p.d. across them.

Solution. Equivalent capacitance between points A and B is

$$C_2 + C_3 = 5 + 3 = 8 \mu\text{F}$$

Capacitance of the whole combination (Fig. 5.21)

$$C = \frac{8 \times 2}{8 + 2} = 1.6 \mu\text{F}$$

Charge on the combination is

$$Q_1 = CV = 100 \times 1.6 = 160 \mu\text{C}$$

$$V_1 = \frac{Q_1}{C_1} = \frac{160}{2} = 80 \text{ V}; V_2 = 100 - 80 = 20 \text{ V}$$

$$Q_2 = C_2 V_2 = 3 \times 10^{-6} \times 20 = 60 \mu\text{C}$$

$$Q_3 = C_3 V_2 = 5 \times 10^{-6} \times 20 = 100 \mu\text{C}$$

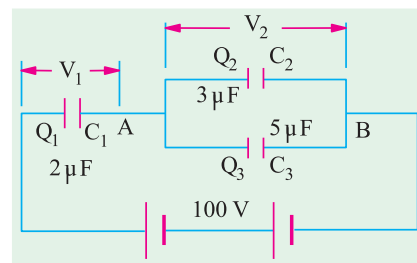

Fig. 5.21

Example 5.16. Two capacitors A and B are connected in series across a 100 V supply and it is observed that the p.d.s. across them are 60 V and 40 V respectively. A capacitor of 2 μF capacitance is now connected in parallel with A and the p.d. across B rises to 90 volts. Calculate the capacitance of A and B in microfarads.

Solution. Let C_1 and $C_2 \mu\text{F}$ be the capacitances of the two capacitors. Since they are connected in series [Fig. 5.22 (a)], the charge across each is the same.

$$\therefore 60 C_1 = 40 C_2 \text{ or } C_1/C_2 = 2/3 \quad \dots(i)$$

In Fig. 5.22 (b) is shown a capacitor of 2 μF connected across capacitor A. Their combined capacitance = $(C_1 + 2) \mu\text{F}$

$$\therefore (C_1 + 2) 10 = 90 C_2 \text{ or } C_1/C_2 = 2/3 \quad \dots(ii)$$

Putting the value of $C_2 = 3C_1/2$ from (i) in (ii) we get

$$\frac{C_1 + 2}{3C_1/2} = 9 \quad \therefore C_1 + 2 = 13.5 C_1$$

or

$$C_1 = 2/12.4 = 0.16 \mu\text{F} \text{ and}$$

$$C_2 = (3/2) \times 0.16 = 0.24 \mu\text{F}$$

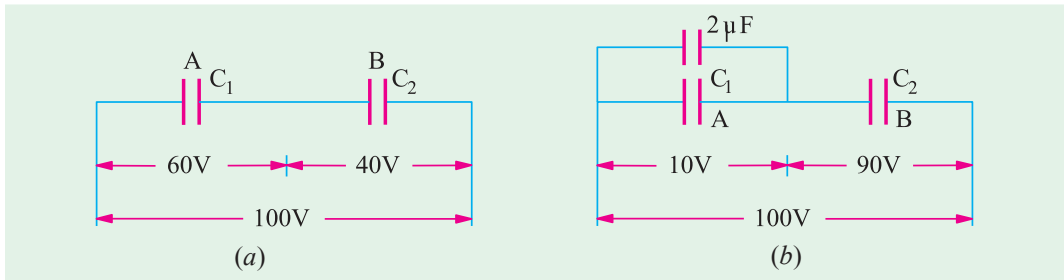

Fig. 5.22

Example 5.17. Three capacitors of $2 \mu\text{F}$, $5 \mu\text{F}$ and $10 \mu\text{F}$ have breakdown voltage of 200 V , 500 V and 100 V respectively. The capacitors are connected in series and the applied direct voltage to the circuit is gradually increased. Which capacitor will breakdown first? Determine the total applied voltage and total energy stored at the point of breakdown. [Bombay University 2001]

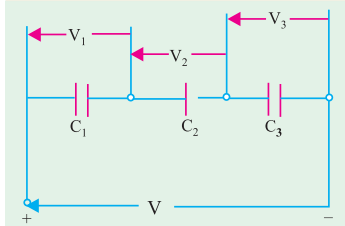

Fig. 5.23

Solution. C_1 of $2 \mu\text{F}$, C_2 of $5 \mu\text{F}$, and C_3 of $10 \mu\text{F}$ are connected in series. If the equivalent single capacitor is C ,

$$1/C = 1/C_1 + 1/C_2 + 1/C_3, \text{ which gives } C = 1.25 \mu\text{F}$$

If V is the applied voltage,

$$V_1 = V \times C/C_1 = V \times (1.25/2)$$

$$= 62.5 \% \text{ of } V$$

$$V_2 = V \times (C/C_2) = C \times (1.25/5) = 25 \% \text{ of } V$$

$$V_3 = V \times (C/C_3) = V \times (1.25/10) = 12.5 \% \text{ of } V$$

If $V_1 = 200$ volts, $V = 320$ volts and $V_2 = 80$ volts, $V_3 = 40$ volts.

It means that, first capacitor C_1 will breakdown first.

$$\text{Energy stored} = 1/2 CV^2 = 1/2 \times 1.25 \times 10^{-6} \times 320 \times 320 = 0.064 \text{ Joule}$$

Example 5.18. A multiple plate capacitor has 10 plates, each of area 10 square cm and separation between 2 plates is 1 mm with air as dielectric. Determine the energy stored when voltage of 100 volts is applied across the capacitor. [Bombay University 2001]

Solution. Number of plates, $n = 10$

$$C = \frac{(n-1)\epsilon_0}{d} = \frac{9 \times 8.854 \times 10^{-12} \times 10 \times 10^{-4}}{1 \times 10^{-3}} = 79.7 \text{ pF}$$

Energy stored

$$= 1/2 \times 79.7 \times 10^{-12} \times 100 \times 100 = 0.3985 \mu\text{J}$$

Example 5.19. Determine the capacitance between the points A and B in figure 5.24 (a). All capacitor values are in μF .

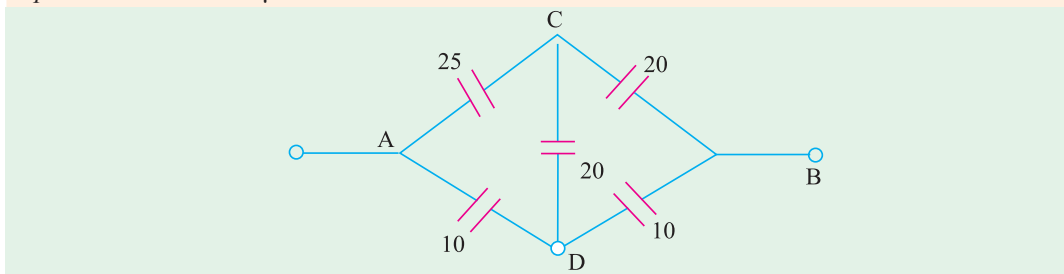

Fig. 5.24 (a)

Solution. Capacitances are being dealt with in this case. For simplifying this, Delta to star transformation is necessary. Formulae for this transformation are known if we are dealing with resistors or impedances. Same formulae are applicable to capacitors provided we are aware that capacitive reactance is dependent on reciprocal of capacitance.

Further steps are given below :

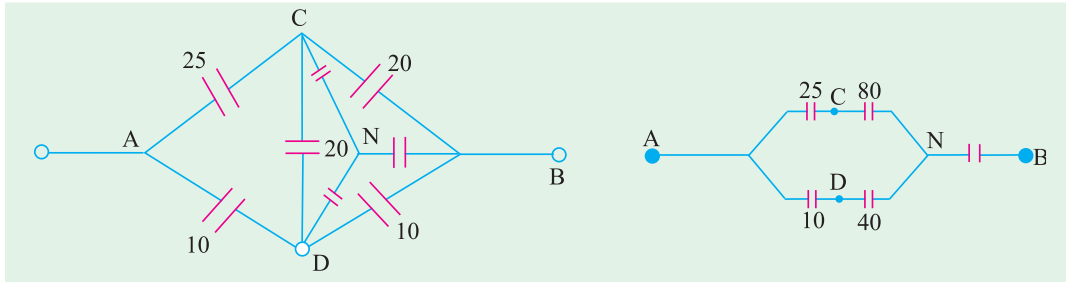

Fig. 5.24 (b)

Fig. 5.24 (c)

Reciprocals of capacitances taken first :

Between B-C — 0.05, Between B-D — 0.10

Between C-D — 0.05, Sum of these three = 0.20

For this delta, star-transformation is done :

Between N-C : $0.05 \times 0.05 / 0.20 = 0.0125$, its reciprocal = $80 \mu F$

Between N-B : $0.05 \times 0.10 / 0.20 = 0.025$, its reciprocal = $40 \mu F$

Between N-D : $0.05 \times 0.10 / 0.20 = 0.025$, its reciprocal = $40 \mu F$

This is marked on Fig. 5.24 (c).

With series-parallel combination of capacitances, further simplification gives the final result.

$$C_{AB} = 16.13 \mu F$$

Note : Alternatively, with ADB as the vertices and C treated as the star point, star to delta transformation can be done. The results so obtained agree with previous effective capacitance of $16.14 \mu F$.

Example 5.20. (a) A capacitor of 10 pF is connected to a voltage source of 100 V . If the distance between the capacitor plates is reduced to 50 % while it remains, connected to the 100 V supply. Find the new values of charge, energy stored and potential as well as potential gradient. Which of these quantities increased by reducing the distance and why ?

[Bombay University 2000]

Solution.

(i) $C = 10 \text{ pF}$

(ii) $C = 20 \text{ pF}$, distance halved

Charge = 1000 p Coul

Charge = 2000 p-coul

Energy = $1/2 CV^2 = 0.05 \mu J$

Energy = $0.10 \mu J$

Potential gradient in the second case will be twice of earlier value.

Example 5.20 (b). A capacitor $5 \mu F$ charged to 10 V is connected with another capacitor of $10 \mu F$ charged to 50 V , so that the capacitors have one and the same voltage after connection. What are the possible values of this common voltage ?

[Bombay University 2000]

Solution. The clearer procedure is discussed here.

Initial charges held by the capacitors are represented by equivalent voltage sources in Fig. 5.25 (b). The circuit is simplified to that in Fig. 5.25 (c). This is the case of C_1 and C_2 connected in series and excited by a 40-V source. If C is the equivalent capacitance of this series-combination,

$$1/C = 1/C_1 + 1/C_2$$

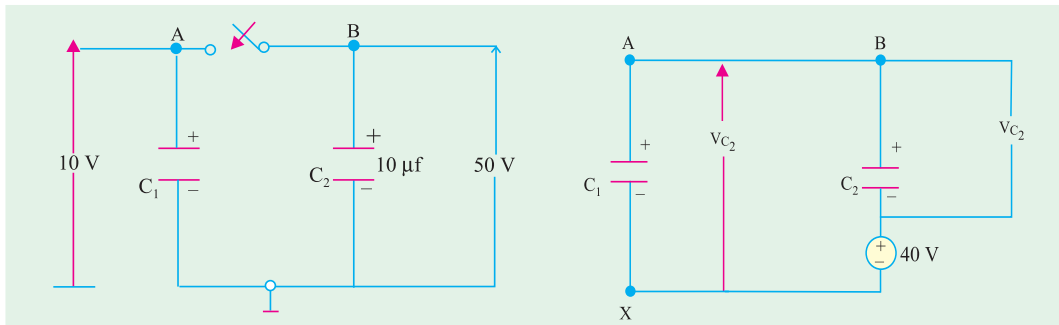

Fig. 5.25 (a)

Fig. 5.25 (c) Simplification

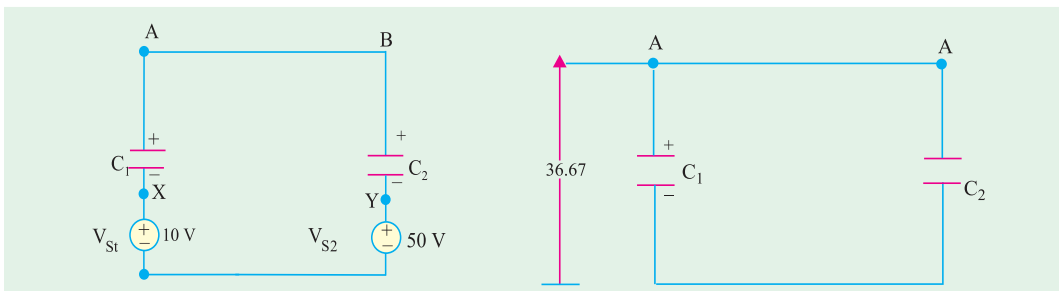

Fig. 5.25 (b). Initial charge represented by equiv-source

Fig. 5.25 (d). Final condition

This gives $C = 3.33 \mu\text{F}$

In Fig. (c), $V_{C1} = 40 \times C/C_1 = 40 \times 3.33/5 = 26.67$ volts

V_{S1} and V_{S2} are integral parts of C_1 and C_2 in Fig. 5.25 (c),

Voltage across $C_1 = 10 + 26.67 = 36.67$ (A w.r. to 0)

Voltage across $C_2 = 50 - 13.33 = 36.67$, (B w.r. to 0)

Thus, the final voltage across the capacitor is 36.67 volts.

Note : If one of the initial voltages on the capacitors happens to be the opposite to the single equivalent source voltage in Fig. 5.25 (c) will be 60 volts. Proceeding similarly, with proper care about signs, the final situation will be the common voltage will be 30 volts.

5.13. Cylindrical Capacitor with Compound Dielectric

Such a capacitor is shown in Fig. 5.26

Let r_1 = radius of the core

r_2 = radius of inner dielectric ϵ_{r1}

r_3 = radius of outer dielectric ϵ_{r2}

Obviously, there are two capacitors joined in series.

Now

$$C_1 = \frac{0.024 \epsilon_{r1}}{\log_{10} (r_2/r_1)} \mu\text{F/km} \text{ and } C_2 = \frac{0.024 \epsilon_{r2}}{\log_{10} (r_3/r_2)} \mu\text{F/M}$$

$$\text{Total capacitance of the cable is } C = \frac{C_1 C_2}{C_1 + C_2}$$

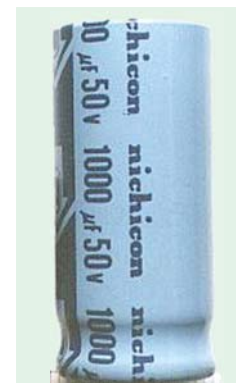

A cylindrical Capacitor

Now for capacitors joined in series, charge is the same.

$$\therefore Q = C_1 V_1 = C_2 V_2$$

$$\text{or } \frac{V_2}{V_1} = \frac{C_1}{C_2} = \frac{\epsilon_{r1} \log_{10} (r_3/r_2)}{\epsilon_{r1} \log_{10} (r_2/r_1)}$$

From this relation, V_2 and V_1 can be found,

$$g_{max} \text{ in inner capacitor } \frac{V_1}{2.3 r_1 \log_{10}(r_2/r_1)}$$

(Art. 5.9)

$$\text{Similarly, } g_{max} \text{ for outer capacitor } = \frac{V_2}{2.3 r_2 \log_{10}(r_3/r_2)}$$

$$\begin{aligned} \therefore \frac{g_{max}}{g_{max}} &= \frac{V_1}{2.3 r_1 \log_{10}(r_2/r_1)} \div \frac{V_2}{2.3 r_2 \log_{10}(r_3/r_2)} \\ &= \frac{V_1 r_2}{V_2 r_1} \times \frac{\log_{10} (r_3/r_2)}{\log_{10} (r_2/r_1)} = \frac{C_2 r_2}{C_1 r_1} \times \frac{\log_{10} (r_3/r_2)}{\log_{10} (r_2/r_1)} \left(\because \frac{V_1}{V_2} = \frac{C_2}{C_1} \right) \end{aligned}$$

Putting the values of C_1 and C_2 , we get

$$\frac{g_{max 1}}{g_{max 2}} = \frac{0.024 \epsilon_{r2}}{\log_{10}(r_3/r_2)} \times \frac{\log_{10} (r_3/r_2)}{0.024 \epsilon_{r1}} = \frac{r_2}{r_1} \times \frac{\log_{10} (r_2/r_1)}{\log_{10} (r_2/r_1)} \therefore \frac{g_{max 1}}{g_{max 2}} = \frac{\epsilon_{r2} \cdot r_2}{\epsilon_{r1} \cdot r_1}$$

Hence, voltage gradient is inversely proportional to the permittivity and the inner radius of the insulating material.

Example 5.21. A single-core lead-sheathed cable, with a conductor diameter of 2 cm is designed to withstand 66 kV. The dielectric consists of two layers A and B having relative permittivities of 3.5 and 3 respectively. The corresponding maximum permissible electrostatic stresses are 72 and 60 kV/cm. Find the thicknesses of the two layers. **(Power Systems-I, M.S. Univ. Baroda)**

Solution. As seen from Art. 5.13.

$$\frac{g_{max 1}}{g_{max 2}} = \frac{\epsilon_{r2} \cdot r_2}{\epsilon_{r1} \cdot r_1} \text{ or } \frac{72}{60} = \frac{3 \times r_2}{3.5 \times 1} \text{ or } r_2 = 1.4 \text{ cm}$$

$$\text{Now, } g_{max} = \frac{V_1 \times \sqrt{2}}{2.3 r_1 \log_{10} r_2/r_1} \quad \dots \text{Art. 5.9}$$

where V_1 is the r.m.s. values of the voltage across the first dielectric.

$$\therefore 72 = \frac{V_1 \times \sqrt{2}}{2.3 \times 1 \times \log_{10} 1.4} \text{ or } V_1 = 17.1 \text{ kV}$$

$$\text{Obviously, } V_2 = 66 - 17.1 = 48.9 \text{ kV}$$

$$\text{Now, } g_{max 2} = \frac{V_2 \times \sqrt{2}}{2.3 r_2 \log_{10} (r_3/r_2)} \therefore 60 = \frac{48.9}{2.3 \times 1.4 \log_{10} (r_3/r_2)}$$

$$\therefore \log_{10} (r_3/r_2) = 0.2531 = \log_{10} (1.79) \therefore \frac{r_3}{r_2} = 1.79 \text{ or } r_3 = 2.5 \text{ cm}$$

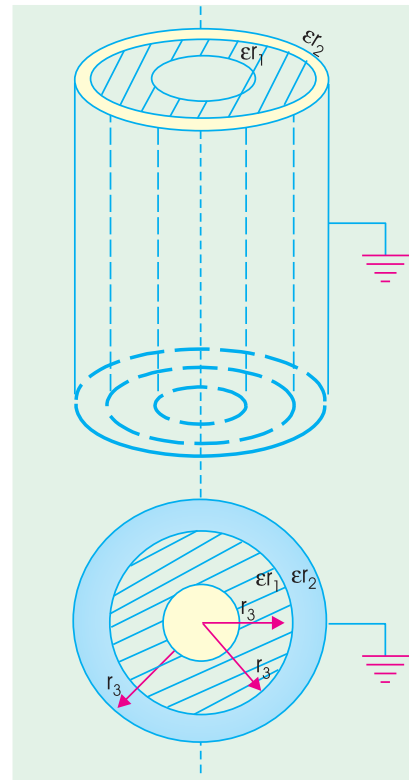

Fig. 5.26

Thickness of first dielectric layer = $1.4 - 1.0 = 0.4 \text{ cm}$.

Thickness of second layer = $2.5 - 1.4 = 1.1 \text{ cm}$.

5.14. Insulation Resistance of a Cable Capacitor

In a cable capacitor, useful current flows along the axis of the core but there is always present some leakage of current. This leakage is radial *i.e.* at right angles to the flow of useful current. The

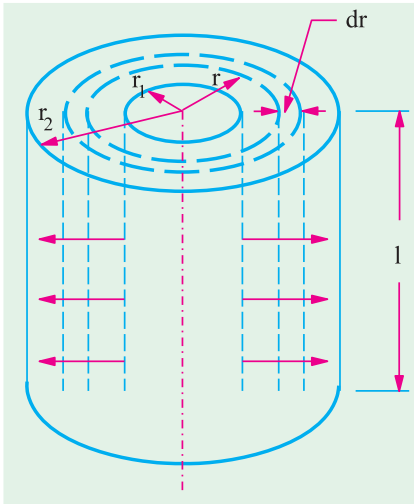

Fig. 5.27

resistance offered to this radial leakage of current is called **insulation resistance** of the cable. If cable length is greater, then leakage is also greater. It means that more current will leak. In other words, insulation resistance is decreased. Hence, we find that insulation resistance is inversely proportional to the cable length. This insulation resistance is not to be confused with conductor resistance which is directly proportional to the cable length.

Consider l metre of a single-core cable of inner-radius r_1 and outer radius r_2 (Fig. 5.27). Imagine an annular ring of radius ' r ' and radial thickness ' dr '.

If resistivity of insulating material is ρ , then resistance of the this narrow ring is $dR = \frac{\rho dr}{2\pi r \times l} = \frac{\rho dr}{2\pi r l}$. ∴ Insulation resistance of l metre length of cable is

$$\int dR = \int_{r_1}^{r_2} \frac{\rho dr}{2\pi r l} \text{ or } R = \frac{\rho}{2\pi r l} \left| \log_e (r) \right|_{r_1}^{r_2}$$

$$R = \frac{\rho}{2\pi l} \log_e (r_2/r_1) = \frac{2.3 \rho}{2\pi l} \log_{10} (r_2/r_1) \Omega$$

It should be noted

- (i) that R is inversely proportional to the cable length
- (ii) that R depends upon the ratio r_2/r_1 and NOT on the thickness of insulator itself.

Example 5.22. A liquid resistor consists of two concentric metal cylinders of diameters $D = 35 \text{ cm}$ and $d = 20 \text{ cm}$ respectively with water of specific resistance $\rho = 8000 \Omega \text{ cm}$ between them. The length of both cylinders is 60 cm . Calculate the resistance of the liquid resistor.

(Elect. Engg. Aligarh Univ.,)

Solution. $r_1 = 10 \text{ cm}$; $r_2 = 17.5 \text{ cm}$; $\log_{10} (1.75) = 0.243$
 $\rho = 8 \times 10^3 \Omega\text{-cm}$; $l = 60 \text{ cm}$.

Resistance of the liquid resistor $R = \frac{2.3 \times 8 \times 10^3}{2\pi \times 60} \times 0.243 = 11.85 \Omega$.

Example 5.23. Two underground cables having conductor resistances of 0.7Ω and 0.5Ω and insulation resistance of $300 \text{ M}\Omega$ respectively are joined (i) in series (ii) in parallel. Find the resultant conductor and insulation resistance.

(Elect. Engineering, Calcutta Univ.)

Solution. (i) The conductor resistance will add like resistances in series. However, the leakage resistances will decrease and would be given by the reciprocal relation.

Total conductor resistance = $0.7 + 0.5 = 1.2 \Omega$

If R is the combined leakage resistance, then

$$\frac{1}{R} = \frac{1}{300} + \frac{1}{600} \quad \therefore R = 200 \text{ M}\Omega$$

(ii) In this case, conductor resistance is $= 0.7 \times 0.5 / (0.7 + 0.5) = 0.3 \text{ } \Omega$ (approx)

Insulation resistance $= 300 + 600 = 900 \text{ M } \Omega$

Example 5.24. The insulation resistance of a kilometre of the cable having a conductor diameter of 1.5 cm and an insulation thickness of 1.5 cm is 500 M Ω . What would be the insulation resistance if the thickness of the insulation were increased to 2.5 cm ?

(Communication Systems, Hyderabad Univ. 1992)

Solution. The insulation resistance of a cable is

$$\text{First Case} \quad R = \frac{2.3 \rho}{2\pi l} \log_{10} (r_2/r_1)$$

$$r_1 = 1.5/2 = 0.75 \text{ cm} ; r_2 = 0.75 + 1.5 = 2.25 \text{ cm}$$

$$\therefore r_2/r_1 = 2.25/0.75 = 3 ; \log_{10} (3) = 0.4771 \quad \therefore 500 = \frac{2.3 \rho}{2\pi l} \times 0.4771 \quad \dots(i)$$

Second Case

$$r_1 = 0.75 \text{ cm} \text{ --as before } r_2 = 0.75 + 2.5 = 3.25 \text{ cm}$$

$$r_2/r_1 = 3.25/0.75 = 4.333 ; \log_{10} (4.333) = 0.6368 \quad \therefore R = \frac{2.4 \rho}{2\pi l} \times 0.6368 \quad \dots(ii)$$

Dividing Eq. (ii) by Eq. (i), we get

$$\frac{R}{500} = \frac{0.6368}{0.4771} ; R = 500 \times 0.6368 / 0.4771 = 667.4 \text{ M } \Omega$$

5.15. Energy Stored in a Capacitor

Charging of a capacitor always involves some expenditure of energy by the charging agency. This energy is stored up in the electrostatic field set up in the dielectric medium. On discharging the capacitor, the field collapses and the stored energy is released.

To begin with, when the capacitor is uncharged, little work is done in transferring charge from one plate to another. But further instalments of charge have to be carried against the repulsive force due to the charge already collected on the capacitor plates. Let us find the energy spent in charging a capacitor of capacitance C to a voltage V .

Suppose at any stage of charging, the p.d. across the plates is v . By definition, it is equal to the work done in shifting one coulomb from one plate to another. If 'dq' is charge next transferred, the work done is

$$dW = v.dq$$

$$\text{Now} \quad q = Cv \quad \therefore dq = C.dv \quad \therefore dW = Cv.dv$$

Total work done in giving V units of potential is

$$W = \int_0^V Cv.dv = C \left[\frac{v^2}{2} \right]_0^V \quad \therefore W = \frac{1}{2} CV^2$$

If C is in farads and V is in volts, then $W = \frac{1}{2} CV^2$ joules $= \frac{1}{2} QV$ joules $= \frac{Q^2}{2C}$ joules

If Q is in coulombs and C is in farads, the energy stored is given in joules.



Capacitors on a motherboard

Note : As seen from above, energy stored in a capacitor is $E = \frac{1}{2} CV^2$

Now, for a capacitor of plate area $A \text{ m}^2$ and dielectric of thickness d metre, energy per unit volume of dielectric medium.

$$\frac{1}{2} \frac{CV^2}{Ad} = \frac{1}{2} \frac{A}{d} \cdot \frac{V^2}{Ad} = \frac{1}{2} \frac{V^2}{d} = \frac{1}{2} E^2 = \frac{1}{2} DE = D^2/2 \text{ joules/m}^3 *$$

It will be noted that the formula $\frac{1}{2} DE$ is similar to the expression $\frac{1}{2}$ stress \times strain which is used for calculating the mechanical energy stored per unit volume of a body subjected to elastic stress.

Example 5.25. Since a capacitor can store charge just like a lead-acid battery, it can be used at least theoretically as an electrostatic battery. Calculate the capacitance of 12-V electrostatic battery which the same capacity as a 40 Ah, 12 V lead-acid battery.

Solution. Capacity of the lead-acid battery = 40 Ah = 40 \times 36 As = 144000 Coulomb

Energy stored in the battery = $QV = 144000 \times 12 = 1.728 \times 10^6 \text{ J}$

Energy stored in an electrostatic battery = $\frac{1}{2} CV^2$

$$\therefore \frac{1}{2} \times C \times 12^2 = 1.728 \times 10^6 \therefore C = 2.4 \times 10^4 \text{ F} = 24 \text{ kF}$$

Example 5.26. A capacitor-type stored-energy welder is to deliver the same heat to a single weld as a conventional welder that draws 20 kVA at 0.8 pf for 0.0625 second/weld. If $C = 2000 \mu\text{F}$, find the voltage to which it is charged. **(Power Electronics, A.M.I.E. Sec B, 1993)**

Solution. The energy supplied per weld in a conventional welder is

$$W = VA \times \cos \phi \times \text{time} = 20,000 \times 0.8 \times 0.0625 = 1000 \text{ J}$$

Now, energy stored in a capacitor is $(1/2) CV^2$

$$\therefore W = \frac{1}{2} CV^2 \text{ or } V = \sqrt{\frac{2W}{C}} = \sqrt{\frac{2 \times 1000}{2000 \times 10^{-6}}} = 1000 \text{ V}$$

Example 5.27. A parallel-plate capacitor is charged to 50 μC at 150 V. It is then connected to another capacitor of capacitance 4 times the capacitance of the first capacitor. Find the loss of energy. **(Elect. Engg. Aligarh Univ.)**

Solution. $C_1 = 50/150 = 1/3 \mu\text{F}$; $C_2 = 4 \times 1/3 = 4/3 \mu\text{F}$

Before Joining

$$E_1 = \frac{1}{2} C_1 V_1^2 = \frac{1}{2} \times \left(\frac{1}{3}\right) 10^{-6} \times 150^2 = 37.5 \times 10^{-4} \text{ J}; E_2 = 0$$

$$\text{Total energy} = 37.5 \times 10^{-4} \text{ J}$$

After Joining

When the two capacitors are connected in parallel, the charge of 50 μC gets redistributed and the two capacitors come to a common potential V .

$$V = \frac{\text{total charge}}{\text{total capacitance}} = \frac{50 \mu\text{C}}{[(1/3) + (4/3)] \mu\text{F}} = 30 \text{ V}$$

$$E_1 = \frac{1}{2} \times (1/3) \times 10^{-6} \times 30^2 = 1.5 \times 10^{-4} \text{ J}$$

$$E_2 = \frac{1}{2} \times (4/3) \times 10^{-6} \times 30^2 = 6.0 \times 10^{-4} \text{ J}$$

$$\text{Total energy} = 7.5 \times 10^{-4} \text{ J}; \text{ Loss of energy} = (37.5 - 7.5) \times 10^{-4} = 3 \times 10^{-2} \text{ J}$$

The energy is wasted away as heat in the conductor connecting the two capacitors.

* It is similar to the expression for the energy stored per unit volume of a magnetic field.

Example 5.28. An air-capacitor of capacitance $0.005 \mu F$ is connected to a direct voltage of $500 V$, is disconnected and then immersed in oil with a relative permittivity of 2.5 . Find the energy stored in the capacitor before and after immersion. (Elect. Technology : London Univ.)

Solution. Energy before immersion is

$$E_1 = \frac{1}{2} CV^2 = \frac{1}{2} \times 0.005 \times 10^{-6} \times 500^2 = 625 \times 10^{-6} \text{ J}$$

When immersed in oil, its capacitance is increased 2.5 times. Since charge is constant, voltage must become 2.5 times. Hence, new capacitance is $2.5 \times 0.005 = 0.0125 \mu F$ and new voltage is $500/2.5 = 200 V$.

$$E_2 = \frac{1}{2} \times 0.0125 \times 10^{-6} \times (200)^2 = 250 \times 10^{-6} \text{ J}$$

Example 5.29. A parallel-plate air capacitor is charged to $100 V$. Its plate separation is 2 mm and the area of each of its plate is 120 cm^2 .

Calculate and account for the increase or decrease of stored energy when plate separation is reduced to 1 mm

(a) at constant voltage (b) at constant charge.

Solution. Capacitance in the first case

$$C_1 = \frac{\epsilon_0 A}{d} = \frac{8.854 \times 10^{-12} \times 120 \times 10^{-4}}{2 \times 10^{-3}} = 53.1 \times 10^{-12} \text{ F}$$

Capacitance in the second case i.e. with reduced spacing

$$C_2 = \frac{8.854 \times 10^{-12} \times 120 \times 10^{-4}}{1 \times 10^{-3}} = 106.2 \times 10^{-12} \text{ F}$$

(a) When Voltage is Constant

$$\begin{aligned} \text{Change in stored energy } dE &= \frac{1}{2} C_2 V^2 - \frac{1}{2} C_1 V^2 \\ &= \frac{1}{2} \times 100^2 \times (106.2 - 53.1) \times 10^{-12} = 26.55 \times 10^{-8} \text{ J} \end{aligned}$$

This represents an increase in the energy of the capacitor. This extra work has been done by the external supply source because charge has to be given to the capacitor when its capacitance increases, voltage remaining constant.

(b) When Charge Remains Constant

$$\text{Energy in the first case } E_1 = \frac{1}{2} \frac{Q^2}{C_1}; \text{ Energy in the second case, } E_2 = \frac{1}{2} \frac{Q^2}{C_2}$$

$$\begin{aligned} \therefore \text{ change in energy is } dE &= \frac{1}{2} Q^2 \left(\frac{1}{53.1} - \frac{1}{106.2} \right) \times 10^{12} \text{ J} \\ &= \frac{1}{2} (C_1 V_1)^2 \left(\frac{1}{53.1} - \frac{1}{106.2} \right) \times 10^{12} \text{ J} \\ &= \frac{1}{2} (53.1 \times 10^{-12})^2 \times 10^4 \times 0.0094 \times 10^{12} \\ &= 13.3 \times 10^{-8} \text{ joules} \end{aligned}$$

Hence, there is a decrease in the stored energy. The reason is that charge remaining constant, when the capacitance is increased, then voltage must fall with a consequent decrease in stored energy

$$(E = \frac{1}{2} QV)$$

Example 5.30. A point charge of $100 \mu\text{C}$ is embedded in an extensive mass of bakelite which has a relative permittivity of 5. Calculate the total energy contained in the electric field outside a radial distance of (i) 100 m (ii) 10 m (iii) 1 m and (iv) 1 cm.

Solution. As per the Coulomb's law, the electric field intensity at any distance x from the point charge is given by $E = Q/4\pi\epsilon x^2$. Let us draw a spherical shell of radius x as shown in Fig. Another spherical shell of radius $(x + dx)$ has also been drawn. A differential volume of the space enclosed between the two shells is $dv = 4\pi x^2 dx$. As per Art. 5.15, the energy stored per unit volume of the electric field is $(1/2)DE$. Hence, differential energy contained in the small volume is

$$dW = \frac{1}{2} DE dv = \frac{1}{2} \epsilon E^2 dv = \frac{1}{2} \epsilon \left(\frac{Q}{4\pi\epsilon x^2} \right)^2 4\pi x^2 dx = \frac{Q^2}{8\pi\epsilon} \cdot \frac{dx}{x^2}$$

Total energy of the electric field extending from $x = R$ to $x = \infty$ is

$$W = \frac{Q^2}{8\pi\epsilon} \int_R^{\infty} x^{-2} dx = \frac{Q^2}{8\pi\epsilon R} = \frac{Q^2}{8\pi\epsilon_0\epsilon_r R}$$

(i) The energy contained in the electric field lying outside a radius of $R = 100$ m is

$$W = \frac{(100 \times 10^{-6})^2}{8\pi \times 8.854 \times 10^{-12} \times 5 \times 100} = \mathbf{0.90 \text{ J}}$$

(ii) For $R = 10$ m, $W = 10 \times 0.09 = \mathbf{0.9 \text{ J}}$

(iii) For $R = 1$ m, $W = 100 \times 0.09 = \mathbf{9 \text{ J}}$

(iv) For $R = 1$ cm, $W = 10,000 \times 0.09 = \mathbf{900 \text{ J}}$

Example 5.31. Calculate the change in the stored energy of a parallel-plate capacitor if a dielectric slab of relative permittivity 5 is introduced between its two plates.

Solution. Let A be the plate area, d the plate separation, E the electric field intensity and D the electric flux density of the capacitor. As per Art. 5.15, energy stored per unit volume of the field is $(1/2)DE$. Since the space volume is $d \times A$, hence,

$$W_1 = \frac{1}{2} D_1 E_1 \times dA = \frac{1}{2} \epsilon_0 E_1^2 \times dA = \frac{1}{2} \epsilon_0 dA \left(\frac{V_1}{d} \right)^2$$

When the dielectric slab is introduced,

$$\begin{aligned} W_2 &= \frac{1}{2} D_2 E_2 \times dA = \frac{1}{2} \epsilon E_2^2 \times dA = \frac{1}{2} \epsilon_0 \epsilon_r dA \left(\frac{V_2}{d} \right)^2 \\ &= \frac{1}{2} \epsilon_0 \epsilon_r dA \left(\frac{V_2}{\epsilon_r d} \right)^2 = \frac{1}{2} \epsilon_0 dA \left(\frac{V_1}{d} \right)^2 \frac{1}{\epsilon_r} \therefore W_2 = \frac{W_1}{\epsilon_r} \end{aligned}$$

It is seen that the stored energy is reduced by a factor of ϵ_r . Hence, change in energy is

$$dW = W_1 - W_2 = W_1 \left(1 - \frac{1}{\epsilon_r} \right) = W_1 \left(1 - \frac{1}{5} \right) = W_1 \times \frac{4}{5} \therefore \frac{dW}{W_1} = \mathbf{0.8}$$

Example 5.32. When a capacitor C charges through a resistor R from a d.c. source voltage E , determine the energy appearing as heat. **[Bombay University, 2000]**

Solution. R-C series circuit switched on to a d.c. source of voltage E , at $t = 0$, results into a current $i(t)$, given by

$$i(t) = (E/R) e^{-t/\tau}$$

where

$$t = RC$$

$$\Delta W_R = \text{Energy appearing as heat in time } \Delta t$$

$$\begin{aligned}
 &= i^2 R \Delta t \\
 \Delta W_R &= \text{Energy appearing as heat in time } \Delta t \\
 &= i^2 R \Delta t \\
 W_R &= R \int_0^\infty i^2 dt \\
 &= R (E/R)^2 \int_0^\infty (\epsilon^{-t/\tau})^2 dt = \frac{1}{2} CE^2
 \end{aligned}$$

Note : Energy stored by the capacitor at the end of charging process = $1/2 CE^2$
Hence, energy received from the source = CF .

5.16. Force of Attraction Between Oppositely-charged Plates

In Fig. 5.28 are shown two parallel conducting plates *A* and *B* carrying constant charges of $+Q$ and $-Q$ coulombs respectively. Let the force of attraction between the two be F newtons. If one of the plates is pulled apart by distance dx , then work done is

$$= F \times dx \text{ joules} \quad \dots(i)$$

Since the plate charges remain constant, no electrical energy comes into the arrangement during the movement dx .

\therefore Work done = change in stored energy

$$\text{Initial stored energy} = \frac{1}{2} \frac{Q^2}{C} \text{ joules}$$

If capacitance becomes $(C - dC)$ due to the movement dx , then

$$\text{Final stored energy} = \frac{1}{2} \frac{Q^2}{(C - dC)} = \frac{1}{2} \cdot \frac{Q^2}{C} \cdot \frac{1}{1 - \frac{dC}{C}} = \frac{1}{2} \frac{Q^2}{C} \left(1 + \frac{dC}{C} \right) \text{ if } dC \ll C$$

$$\therefore \text{Change in stored energy} = \frac{1}{2} \frac{Q^2}{C} \left(1 + \frac{dC}{C} \right) - \frac{1}{2} \frac{Q^2}{C} = \frac{1}{2} \frac{Q^2}{C^2} \cdot dC \quad \dots(ii)$$

$$\text{Equating Eq. (i) and (ii), we have } F \cdot dx = \frac{1}{2} \frac{Q^2}{C^2} \cdot dC$$

$$F = \frac{1}{2} \frac{Q^2}{C^2} \cdot \frac{dC}{dx} = \frac{1}{2} V^2 \cdot \frac{dC}{dx} \quad (\because V = Q/C)$$

$$\text{Now } C = \frac{\epsilon A}{x} \therefore \frac{dC}{dx} = -\frac{\epsilon A}{x^2}$$

$$\therefore F = -\frac{1}{2} V^2 \cdot \frac{\epsilon A}{x^2} = -\frac{1}{2} \epsilon A \left(\frac{V}{x} \right)^2 \text{ newtons} = -\frac{1}{2} \epsilon A E^2 \text{ newtons}$$

This represents the force between the plates of a parallel-plate capacitor charged to a p.d. of V volts. The negative sign shows that it is a force of attraction.

Example 5.33. A parallel-plate capacitor is made of plates 1 m square and has a separation of 1 mm. The space between the plates is filled with dielectric of $\epsilon_r = 25.0$. If 1 k V potential difference is applied to the plates, find the force squeezing the plates together.

(Electromagnetic Theory, A.M.I.E. Sec B, 1993)

Solution. As seen from Art. 5.16, $F = -(1/2) \epsilon_0 \epsilon_r A E^2$ newton
Now $E = V/d = 1000/1 \times 10^{-3} = 10^6$ V/m

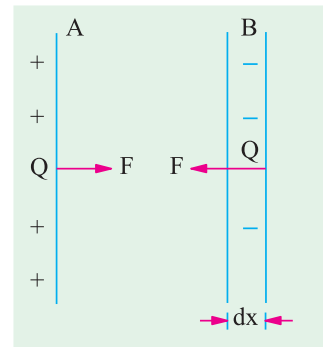

Fig. 5.28

$$\therefore F = -\frac{1}{2} \epsilon_0 \epsilon_r A E^2 = -\frac{1}{2} \times 8.854 \times 10^{-12} \times 25 \times 1 \times (10^6)^2 = -1.1 \times 10^{-4} \text{ N}$$

Tutorial Problems No. 5.2

1. Find the capacitance per unit length of a cylindrical capacitor of which the two conductors have radii 2.5 and 4.5 cm and dielectric consists of two layers whose cylinder of contact is 3.5 cm in radius, the inner layer having a dielectric constant of 4 and the outer one of 6.

[440 pF/m]

2. A parallel-plate capacitor, having plates 100 cm² area, has three dielectrics 1 mm each and of permittivities 3, 4 and 6. If a peak voltage of 2,000 V is applied to the plates, calculate :

- (a) potential gradient across each dielectric
(b) energy stored in each dielectric.

[8.89 kV/cm; 6.67 kV/cm ; 4.44 kV/cm ; 1047, 786, 524 × 10⁻⁷ joule]

3. The core and lead-sheath of a single-core cable are separated by a rubber covering. The cross-sectional area of the core is 16 mm². A voltage of 10 kV is applied to the cable. What must be the thickness of the rubber insulation if the electric field strength in it is not to exceed 6 × 10⁶ V/m ?

[2.5 mm (approx)]

4. A circular conductor of 1 cm diameter is surrounded by a concentric conducting cylinder having an inner diameter of 2.5 cm. If the maximum electric stress in the dielectric is 40 kV/cm, calculate the potential difference between the conductors and also the minimum value of the electric stress.

[18.4 kV ; 16 kV/cm]

5. A multiple capacitor has parallel plates each of area 12 cm² and each separated by a mica sheet 0.2 mm thick. If dielectric constant for mica is 5, calculate the capacitance.

[265.6 μF]

6. A p.d. of 10 kV is applied to the terminals of a capacitor of two circular plates each having an area of 100 sq. cm. separated by a dielectric 1 mm thick. If the capacitance is 3 × 10⁻⁴ microfarad, calculate the electric flux density and the relative permittivity of the dielectric.

[D = 3 × 10⁻⁴ C/m², ε_r = 3.39] (City & Guilds, London)

7. Each electrode of a capacitor of the electrolytic type has an area of 0.02 sq. metre. The relative permittivity of the dielectric film is 2.8. If the capacitor has a capacitance of 10 μF, estimate the thickness of the dielectric film.

[4.95 × 10⁻⁸ m] (I.E.E. London)

5.17. Current-Voltage Relationships in a Capacitor

The charge on a capacitor is given by the expression $Q = CV$. By differentiating this relation, we get

$$i = \frac{dQ}{dt} = \frac{d}{dt} (CV) = C \frac{dV}{dt}$$

Following important facts can be deduced from the above relations :

- (i) since $Q = CV$, it means that the voltage across a capacitor is proportional to *charge*, not the *current*.
- (ii) a capacitor has the ability to store charge and hence to provide a sort of memory.
- (iii) a capacitor can have a voltage across it even when there is *no current flowing*.
- (iv) from $i = c dV/dt$, it is clear that current in the capacitor is present only when voltage on it changes with time. If $dV/dt = 0$ *i.e.* when its voltage is constant or for d.c. voltage, $i = 0$. Hence, the capacitor behaves like an *open circuit*.

(v) from $i = C \, dV/dt$, we have $dV/dt = i/C$. It shows that for a given value of (charge or discharge) current i , rate of change in voltage is inversely proportional to capacitance. Larger the value of C , slower the rate of change in capacitive voltage. Also, capacitor voltage **cannot change instantaneously**.

(vi) the above equation can be put as $dv = \frac{i}{C} \cdot dt$

Integrating the above, we get $\int dv = \frac{1}{C} \int i \cdot dt$ or $dv = \frac{1}{C} \int_0^t i \, dt$

Example 5.34. The voltage across a $5 \mu\text{F}$ capacitor changes uniformly from 10 to 70 V in 5 ms. Calculate (i) change in capacitor charge (ii) charging current.

Solution. $Q = CV \quad \therefore dQ = C \cdot dV$ and $i = C \, dV/dt$

(i) $dV = 70 - 10 = 60 \text{ V}$, $\therefore dQ = 5 \times 60 = 300 \mu\text{C}$.

(ii) $i = C \cdot dV/dt = 5 \times 60/5 = 60 \text{ mA}$

Example 5.35. An uncharged capacitor of 0.01 F is charged first by a current of 2 mA for 30 seconds and then by a current of 4 mA for 30 seconds. Find the final voltage in it.

Solution. Since the capacitor is initially uncharged, we will use the principle of Superposition.

$$V_1 = \frac{1}{0.01} \int_0^{30} 2 \times 10^{-3} \cdot dt = 100 \times 2 \times 10^{-3} \times 30 = 6 \text{ V}$$

$$V_2 = \frac{1}{0.01} \int_0^{30} 4 \times 10^{-3} \cdot dt = 100 \times 4 \times 10^{-3} \times 30 = 12 \text{ V}; \quad \therefore V = V_1 + V_2 = 6 + 12 = 18 \text{ V}$$

Example 5.36. The voltage across two series-connected $10 \mu\text{F}$ capacitors changes uniformly from 30 to 150 V in 1 ms. Calculate the rate of change of voltage for (i) each capacitor and (ii) combination.

Solution. For series combination

$$V_1 = V \frac{C_2}{C_1 + C_2} = \frac{V}{3} \text{ and } V_2 = V \cdot \frac{C_1}{C_1 + C_2} = \frac{2V}{3}$$

When $V = 30 \text{ V}$ $V_1 = V/3 = 30/3 = 10 \text{ V}$; $V_2 = 2V/3 = 2 \times 30/3 = 20 \text{ V}$

When $V = 150 \text{ V}$ $V_1 = 150/3 = 50 \text{ V}$ and $V_2 = 2 \times 150/3 = 100 \text{ V}$

(i) $\therefore \frac{dV_1}{dt} = \frac{(50 - 10)}{1 \text{ ms}} = 40 \text{ kV/s}$; $\frac{dV_2}{dt} = \frac{(100 - 20) \text{ V}}{1 \text{ ms}} = 80 \text{ kV/s}$

(ii) $\frac{dV}{dt} = \frac{(150 - 30)}{1 \text{ ms}} = 120 \text{ kV/s}$

It is seen that $dV/dt = dV_1/dt + dV_2/dt$.

5.18. Charging of a Capacitor

In Fig. 5.29. (a) is shown an arrangement by which a capacitor C may be charged through a high resistance R from a battery of V volts. The voltage across C can be measured by a suitable voltmeter. When switch S is connected to terminal (a), C is charged but when it is connected to b , C is short circuited through R and is thus discharged. As shown in Fig. 5.29. (b), switch S is shifted to a for charging the capacitor for the battery. The voltage across C does not rise to V instantaneously but builds up slowly *i.e.* exponentially and not linearly. Charging current i_c is maximum at the start *i.e.* when C is uncharged, then it decreases exponentially and finally ceases when p.d. across capacitor plates becomes equal and opposite to the battery voltage V . At any instant during charging, let

v_c = p.d. across C ; i_c = charging current

q = charge on capacitor plates

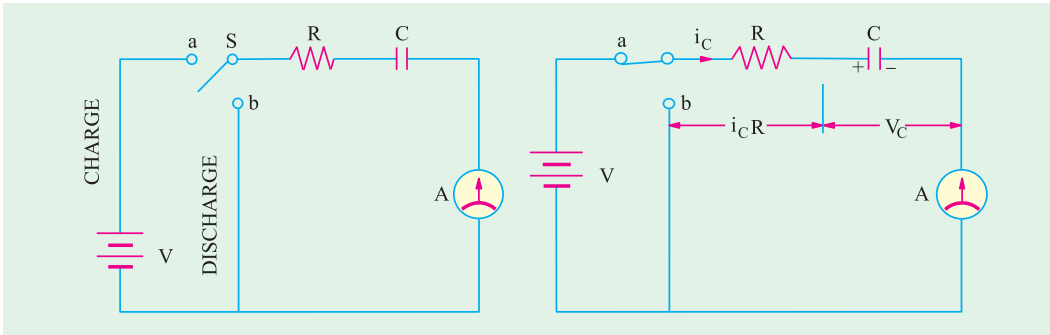

Fig. 5.29

The applied voltage V is always equal to the sum of :

(i) resistive drop ($i_c R$) and (ii) voltage across capacitor (v_c)

$$\therefore V = i_c R + v_c \quad \dots(i)$$

$$\text{Now } i_c = \frac{dq}{dt} = \frac{d}{dt}(Cv_c) = C \frac{dv_c}{dt} \therefore V = v_c + CR \frac{dv_c}{dt} \quad \dots(ii)$$

$$\text{or } -\frac{dv_c}{V - v_c} = -\frac{dt}{CR}$$

$$\text{Integrating both sides, we get } \int \frac{-dV_c}{V - v_c} = -\frac{1}{CR} \int dt; \therefore \log_e (V - v_c) = -\frac{t}{CR} + K \quad \dots(iii)$$

where K is the constant of integration whose value can be found from initial known conditions. We know that at the start of charging when $t = 0$, $v_c = 0$.

Substituting these values in (iii), we get $\log_e V = K$

$$\text{Hence, Eq. (iii) becomes } \log_e (V - v_c) = \frac{-t}{CR} + \log_e V$$

$$\text{or } \log_e \frac{V - v_c}{V} = \frac{-t}{CR} = -\frac{t}{\lambda} \text{ where } \lambda = CR = \text{time constant}$$

$$\therefore \frac{V - v_c}{V} = e^{-t/\lambda} \text{ or } v_c = V(1 - e^{-t/\lambda}) \quad \dots(iv)$$

This gives variation with time of voltage across the capacitor plates and is shown in Fig. 5.27.(a)

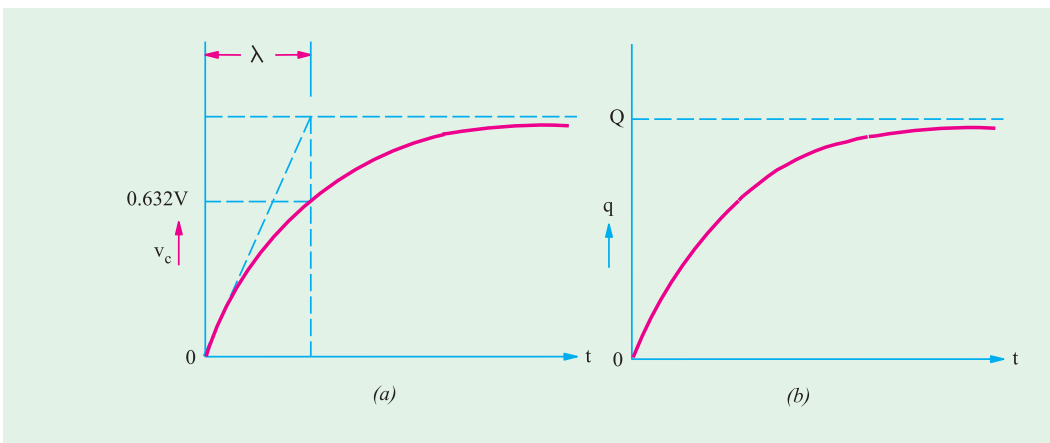

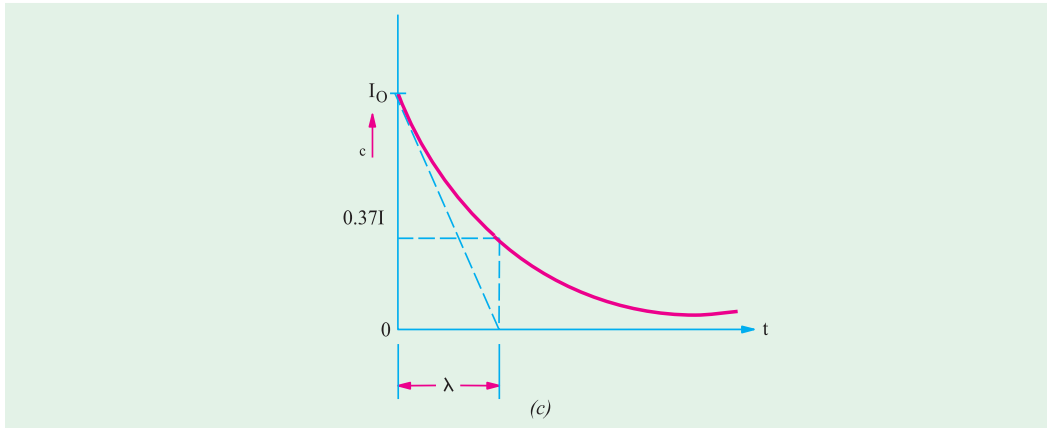

Fig. 5.30

Now $v_c = q/C$ and $V = Q/C$

Equation (iv) becomes $\frac{q}{C} = \frac{Q}{C} (1 - e^{-t/\lambda}) \therefore q = Q (1 - e^{-t/\lambda})$... (v)

We find that increase of charge, like growth of potential, follows an exponential law in which the steady value is reached after infinite time (Fig. 5.30 b). Now, $i_c = dq/dt$.

Differentiating both sides of Eq. (v), we get

$$\begin{aligned} \frac{dq}{dt} &= i_c = Q \frac{d}{dt} (1 - e^{-t/\lambda}) = Q \left(+ \frac{1}{\lambda} e^{-t/\lambda} \right) \\ &= \frac{Q}{\lambda} e^{-t/\lambda} = \frac{CV}{CR} e^{-t/\lambda} \quad (\because Q = CV \text{ and } \lambda = CR) \end{aligned}$$

$$\therefore i_c = \frac{V}{R} \cdot e^{-t/\lambda} \text{ or } i_c = I_0 e^{-t/\lambda} \quad \dots (vi)$$

where $I_0 = \text{maximum current} = V/R$

Exponentially rising curves for v_c and q are shown in Fig. 5.30 (a) and (b) respectively. Fig. 5.30 (c) shows the curve for exponentially decreasing charging current. It should be particularly noted that i_c decreases in magnitude only but its direction of flow remains the same *i.e.* positive.

As charging continues, charging current decreases according to equation (vi) as shown in Fig. 5.30 (c). It becomes zero when $t = \infty$ (though it is almost zero in about 5 time constants). Under steady-state conditions, the circuit appears only as a capacitor which means it acts as an open-circuit. Similarly, it can be proved that v_R decreases from its initial maximum value of V to zero exponentially as given by the relation $v_R = V e^{-t/\lambda}$.

5.19. Time Constant

(a) Just at the start of charging, p.d. across capacitor is zero, hence from (ii) putting $v_c = 0$, we get

$$V = CR \frac{dv_c}{dt}$$

$$\therefore \text{initial rate of rise of voltage across the capacitor is}^* = \left(\frac{dv_c}{dt} \right)_{t=0} = \frac{V}{CR} = \frac{V}{\lambda} \text{ volt/second}$$

If this rate of rise were maintained, then time taken to reach voltage V would have been $V + V/CR = CR$. This time is known as **time constant** (λ) of the circuit.

* It can also be found by differentiating Eq. (iv) with respect to time and then putting $t = 0$.

Hence, time constant of an R - C circuit is defined as *the time during which voltage across capacitor would have reached its maximum value V had it maintained its initial rate of rise.*

(b) In equation (iv) if $t = \lambda$, then

$$v_c = V(1 - e^{-t/\lambda}) = V(1 - e^{-\lambda/\lambda}) = V(1 - e^{-1}) = V\left(1 - \frac{1}{e}\right) = V\left(1 - \frac{1}{2.718}\right) = 0.632 V$$

Hence, time constant may be defined as *the time during which capacitor voltage actually rises to 0.632 of its final steady value.*

(c) From equation (vi), by putting $t = \lambda$, we get

$$i_c = I_0 e^{-\lambda/\lambda} = I_0 e^{-1} = I_0/2.718 \cong 0.37 I_0$$

Hence, the constant of a circuit is also the *time during which the charging current falls to 0.37 of its initial maximum value (or falls by 0.632 of its initial value).*

5.20. Discharging of a Capacitor

As shown in Fig. 5.31 (a), when S is shifted to b , C is discharged through R . It will be seen that the discharging current flows in a direction opposite to that the charging current as shown in Fig. 5.31(b). Hence, if the direction of the charging current is taken positive, then that of the discharging current will be taken as negative. To begin with, the discharge current is maximum but then decreases exponentially till it ceases when capacitor is fully discharged.

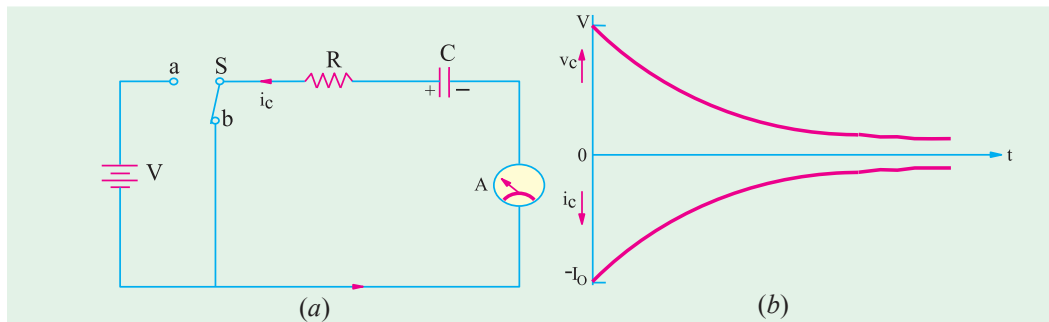

Fig. 5.31

Since battery is cut of the circuit, therefore, by putting $V = 0$ in equation (ii) of Art. 5.18, we get

$$0 = CR \frac{dv_c}{dt} - v_c \quad \text{or} \quad v_c = CR \frac{dv_c}{dt} \quad \left(i_c = C \frac{dv_c}{dt} \right)$$

$$\therefore \frac{dv_c}{v_c} = \frac{dt}{CR} \quad \text{or} \quad \frac{dv_c}{v_c} = \frac{1}{CR} dt \quad \log_e v_c = \frac{t}{CR} + k$$

At the start of discharge, when $t = 0$, $v_c = V$ $\therefore \log_e V = 0 + K$; or $\log_e V = K$

Putting this value above, we get

$$\log_e v_c = -\frac{t}{\lambda} + \log_e V \quad \text{or} \quad \log_e v_c/V = -t/\lambda$$

$$\text{or} \quad \frac{v_c}{V} = e^{-t/\lambda} \quad \text{or} \quad v_c = V e^{-t/\lambda}$$

$$\text{Similarly,} \quad q = Q e^{-t/\lambda} \quad \text{and} \quad i_c = -I_0 e^{-t/\lambda}$$

It can be proved that

$$v_R = -V e^{-t/\lambda}$$

The fall of capacitor potential and its discharging current are shown in Fig. 5.32 (b).

One practical application of the above charging and discharging of a capacitor is found in digital

control circuits where a square-wave input is applied across an R - C circuit as shown in Fig. 5.32 (a). The different waveforms of the current and voltages are shown in Fig. 5.32 (b), (c), (d), (e). The sharp voltage pulses of V_R are used for control circuits.

Example 5.37. Calculate the current in and voltage drop across each element of the circuit shown in Fig. 5.33 (a) after switch S has been closed long enough for steady-state conditions to prevail.

Also, calculate voltage drop across the capacitor and the discharge current at the instant when S is opened.

Solution. Under steady-state conditions, the capacitor becomes fully charged and draws no current. In fact, it acts like an open circuit with the result that no current flows through the $1\text{-}\Omega$ resistor. The steady state current I_{SS} flows through loop $ABCD$ only.

Hence,

$$I_{SS} = 100/(6 + 4) = 10 \text{ A}$$

Drop

$$V_6 = 100 \times 6/(6 + 4) = 60 \text{ V}$$

$$V_4 = 100 \times 4/10 = 40 \text{ V}$$

$$V_1 = 0 \times 2 = 0 \text{ V}$$

Voltage across the capacitor = drop across $B-C = 40 \text{ V}$

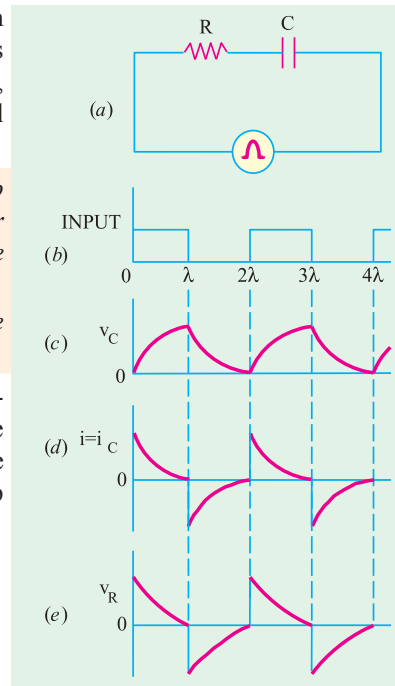

Fig. 5.32

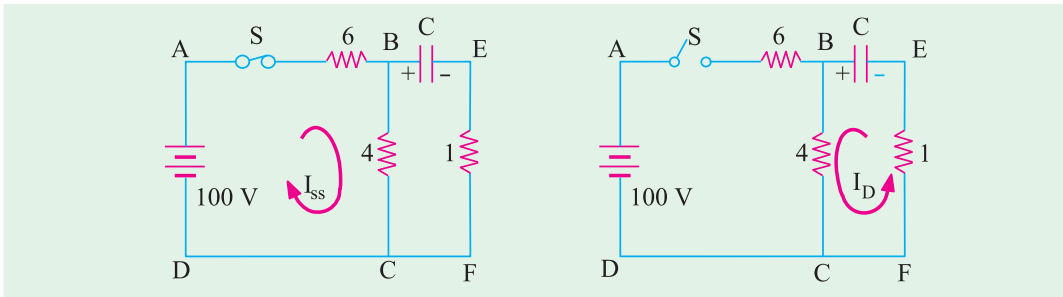

Fig. 5.33

Switch Open

When S is opened, the charged capacitor discharges through the loop $BCFE$ as shown in Fig. 5.33 (b). The discharge current is given by

$$I_D = 40/(4 + 1) = 8 \text{ A}$$

As seen, it flows in a direction opposite to that of I_{SS} .

Example 5.38. (a) A capacitor is charged through a large non-reactive resistance by a battery of constant voltage V . Derive an expression for the instantaneous charge on the capacitor.

(b) For the above arrangement, if the capacitor has a capacitance of $10 \mu\text{F}$ and the resistance is $1 \text{ M}\Omega$ calculate the time taken for the capacitor to receive 90% of its final charge. Also, draw the charge/time curve.

Solution. (a) For this part, please refer to Art. 5.18.

(b) $\lambda = CR = 10 \times 10^{-6} \times 1 \times 10^6 = 10 \text{ s}$; $q = 0.9 Q$

Now, $q = Q (1 - e^{-t/\lambda}) \therefore 0.9 Q = Q (1 - e^{-t/10})$ or $e^{t/10} = 10$

$\therefore 0.1 t \log_e e = \log_e 10$ or $0.1 t = 2.3 \log_{10} 10 = 2.3$ or $t = 23 \text{ s}$

The charge/time curve is similar to that shown in Fig. 5.27 (b).

Example 5.39. A resistance R and a $4 \mu\text{F}$ capacitor are connected in series across a 200 V d.c. supply. Across the capacitor is a neon lamp that strikes (glows) at 120 V . Calculate the value of R to make the lamp strike (glow) 5 seconds after the switch has been closed.

(Electrotechnics-I.M.S. Univ. Baroda)

Solution. Obviously, the capacitor voltage has to rise 120 V in 5 seconds.

$$\therefore 120 = 200 (1 - e^{-5/\lambda}) \quad \text{or} \quad e^{5/\lambda} = 2.5 \quad \text{or} \quad \lambda = 5.464 \text{ second.}$$

$$\text{Now, } \lambda = CR \quad \therefore R = 5.464/4 \times 10^{-6} = \mathbf{1.366 \text{ M}\Omega}$$

Example 5.40. A capacitor of $0.1 \mu\text{F}$ is charged from a 100-V battery through a series resistance of $1,000 \text{ ohms}$. Find

- (a) the time for the capacitor to receive 63.2 % of its final charge.
 (b) the charge received in this time (c) the final rate of charging.
 (d) the rate of charging when the charge is 63.2% of the final charge.

(Elect. Engineering, Bombay Univ.)

Solution. (a) As seen from Art. 5.18 (b), 63.2% of charge is received in a time equal to the time constant of the circuit.

$$\text{Time required} = \lambda = CR = 0.1 \times 10^{-6} \times 1000 = 0.1 \times 10^{-3} = \mathbf{10^{-4} \text{ second}}$$

$$\text{(b) Final charge, } Q = CV = 0.1 \times 100 = 10 \mu\text{C}$$

$$\text{Charge received during this time is} = 0.632 \times 10 = \mathbf{6.32 \mu\text{C}}$$

(c) The rate of charging at any time is given by Eq. (ii) of Art. 5.18.

$$\frac{dv}{dt} = \frac{V - v}{CR}$$

$$\text{Initially } v = 0, \text{ Hence } \frac{dv}{dt} = \frac{V}{CR} = \frac{100}{0.1 \times 10^{-6} \times 10^3} = \mathbf{10^6 \text{ V/s}}$$

$$\text{(d) Here } v = 0.632 \text{ V} = 0.632 \times 100 = 63.2 \text{ volts}$$

$$\therefore \frac{dv}{dt} = \frac{100 - 63.2}{10^{-4}} = \mathbf{368 \text{ kV/s}}$$

Example 5.41. A series combination having $R = 2 \text{ M}\Omega$ and $C = 0.01 \mu\text{F}$ is connected across a d.c. voltage source of 50 V . Determine

- (a) capacitor voltage after 0.02 s , 0.04 s , 0.06 s and 1 hour
 (b) charging current after 0.02 s , 0.04 s , 0.06 s and 0.1 s .

$$\text{Solution. } \lambda = CR = 2 \times 10^6 \times 0.01 \times 10^{-6} = 0.02 \text{ second}$$

$$I_m = V/R = 50/2 \times 10^6 = 25 \mu\text{A.}$$

While solving this question, it should be remembered that (i) in each time constant, v_c increases further by 63.2% of its balance value and (ii) in each constant, i_c decreases to 37% its previous value.

(a) (i) $t = 0.02 \text{ s}$

Since, initially at $t = 0$, $v_c = 0 \text{ V}$ and $V_e = 50 \text{ V}$, hence, in one time constant

$$v_c = 0.632 (50 - 0) = \mathbf{31.6 \text{ V}}$$

(ii) $t = 0.04 \text{ s}$

This time equals two time-constants.

$$\therefore v_c = 31.6 + 0.632 (50 - 31.6) = \mathbf{43.2 \text{ V}}$$

(iii) $t = 0.06 \text{ s}$

This time equals three time-constants.

$$\therefore v_c = 43.2 + 0.632 (50 - 43.2) = \mathbf{47.5 \text{ V}}$$

Since in one hour, steady-state conditions would be established, v_c would have achieved its maximum possible value of **50 V**.

- (b) (i) $t = 0.02$ s, $i_c = 0.37 \times 25 = 9.25 \mu\text{A}$
(ii) $t = 0.4$ s, $i_c = 0.37 \times 9.25 = 3.4 \mu\text{A}$
(iii) $t = 0.06$ s, $i_c = 0.37 \times 3.4 = 1.26 \mu\text{A}$
(iv) $t = 0.1$ s, This time equals 5 time constants. In this time, current falls almost to **zero** value.

Example 5.42. A voltage as shown in Fig. 5.43 (a) is applied to a series circuit consisting of a resistance of 2Ω in series with a pure capacitor of $100 \mu\text{F}$. Determine the voltage across the capacitor at $t = 0.5$ millisecond. [Bombay University, 2000]

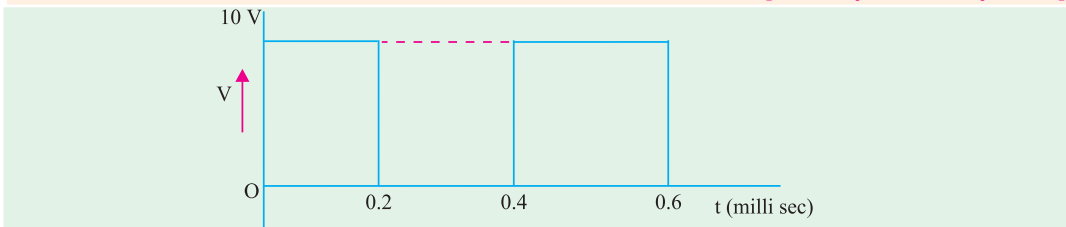

Fig. 5.34 (a)

Solution.

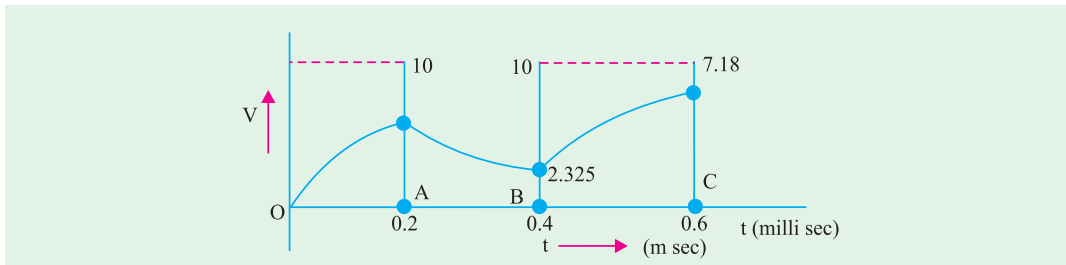

Fig. 5.34 (b)

$$\tau = RC = 0.2 \text{ milli-second}$$

Between 0 and 0.2 m sec;

$$v(t) = 10 [1 - \exp(-t/\tau)]$$

At $t = 0.2$, $v(t) = 6.32$ volts

Between 0.2 and 0.4 m Sec, counting time from A indicating it as t_1

$$v(t_1) = 6.32 \exp(t_1/\tau)$$

At point B, $t_1 = 0.2$, $V = 2.325$

Between 0.4 and 0.6 m Sec, time is counted from B with variable as t_2 ,

$$v(t_2) = 2.325 + (10 - 2.325) [1 - \exp(-t_2/\tau)]$$

At C, $t_2 = 0.2$, $V = 7.716$ volts.

5.21. Transient Relations During Capacitor Charging Cycle

Whenever a circuit goes from one steady-state condition to another steady-state condition, it passes through a transient state which is of short duration. The first steady-state condition is called the **initial condition** and the second steady-state condition is called the **final condition**. In fact, transient condition lies in between the initial and final conditions. For example, when switch S in Fig. 5.35 (a) is not connected either to a or b , the RC circuit is in its initial steady state with no current and

hence no voltage drops. When S is shifted to point a , current starts flowing through R and hence, transient voltages are developed across R and C till they achieve their final steady values. The period during which current and voltage changes take place is called **transient condition**.

The moment switch S is shifted to point 'a' as shown in Fig. 5.35 (b), a charging current i_c is set up which starts charging C that is initially uncharged. At the beginning of the transient state, i_c is maximum because there is no potential across C to oppose the applied voltage V . It has maximum value $= V/R = I_0$. It produces maximum voltage drop across $R = i_c R = I_0 R$. Also, initially, $v_c = 0$, but as time passes, i_c decreases gradually so does v_R but v_c increases exponentially till it reaches the final steady value of V . Although V is constant, v_R and v_c are variable. However, at any time $V = v_R + v_c = i_c R + v_c$.

At the beginning of the transient state, $i_c = I_0$, $v_c = 0$ but $v_R = V$. At the end of the transient state, $i_c = 0$ hence, $v_R = 0$ but $v_c = V$.

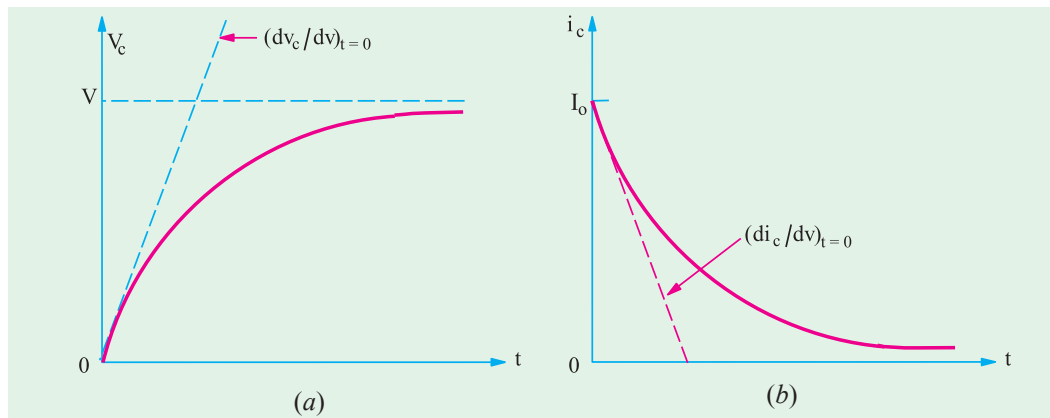

The initial rates of change of v_c , v_R and i_c are given by

$$\begin{aligned} \left(\frac{dv_c}{dt}\right)_{t=0} &= \frac{V}{\lambda} \text{ volt/second,} \\ \left(\frac{dv_R}{dt}\right)_{t=0} &= \frac{I_0 R}{\lambda} = -\frac{V}{\lambda} \text{ volt/second} \\ \left(\frac{di_c}{dt}\right)_{t=0} &= \frac{I_0}{\lambda} \text{ where } I_0 = \frac{V}{R} \end{aligned}$$

These are the initial rates of change. However, their rate of change at any time during the charging transient are given as under :

$$\frac{dv_c}{dt} = \frac{V}{\lambda} e^{-t/\lambda}, \quad \frac{di_c}{dt} = -\frac{dv_R}{dt} = -\frac{V}{\lambda} e^{-t/\lambda}$$

It is shown in Fig. 5.35 (c).

It should be clearly understood that a negative rate of change means a decreasing rate of change. It does not mean that the concerned quantity has reversed its direction.

5.22. Transient Relations During Capacitor Discharging Cycle

As shown in Fig. 5.36 (b), switch S has been shifted to b . Hence, the capacitor undergoes the discharge cycle. Just before the transient state starts, $i_c = 0$, $v_R = 0$ and $v_c = V$. The moment transient

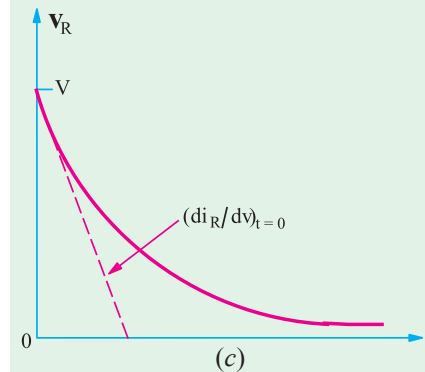

Fig. 5.35

state begins, i_c has maximum value and decreases exponentially to zero at the end of the transient state. So does v_c . However, during discharge, all rates of change have polarity opposite to that during charge. For example, dv_c/dt has a positive rate of change during charging and negative rate of change during discharging.

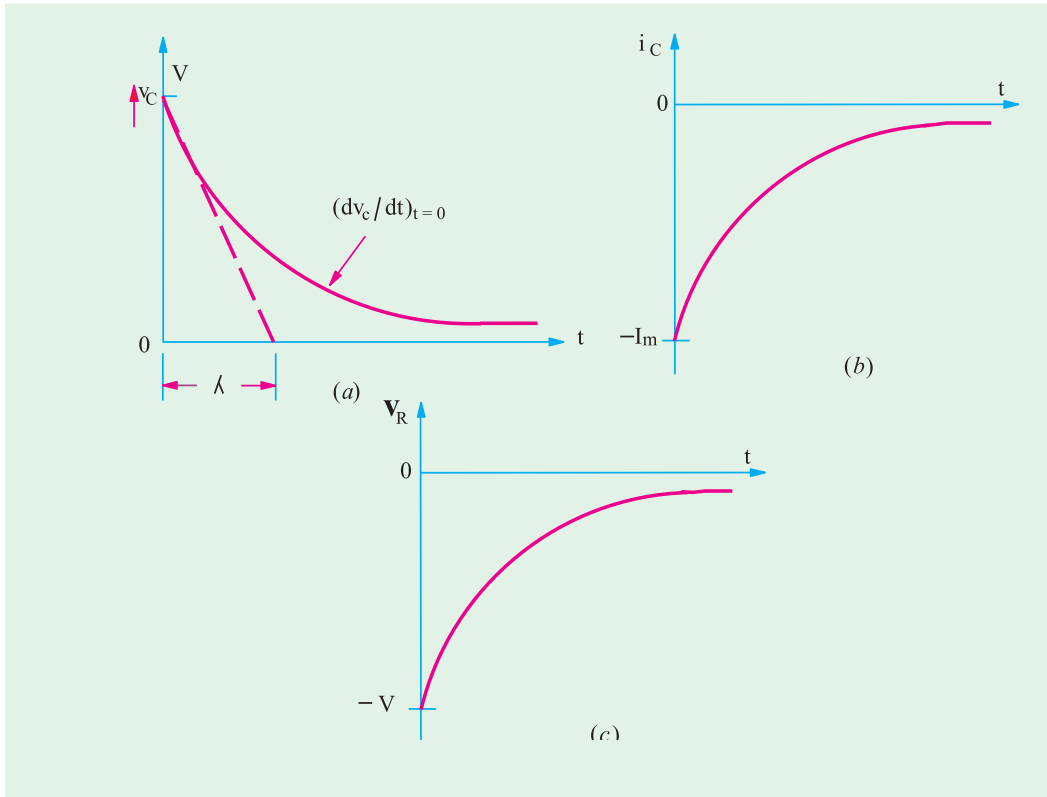

Fig. 5.36

Also, it should be noted that during discharge, v_c maintains its original polarity whereas i_c reverses its direction of flow. Consequently, during capacitor discharge, v_R also reverses its direction.

The various rates of change at *any time* during the discharge transients are as given in Art.

$$\frac{dv_c}{dt} = -\frac{V}{\lambda} e^{-t/\lambda}; \quad \frac{di_c}{dt} = \frac{I_0}{\lambda} e^{-t/\lambda}; \quad \frac{dv_R}{dt} = \frac{V}{\lambda} e^{-t/\lambda}$$

These are represented by the curves of Fig. 5.32.

5.23. Charging and Discharging of a capacitor with Initial Charge

In Art. 5.18, we considered the case when the capacitor was initially uncharged and hence, had no voltage across it. Let us now consider the case, when the capacitor has an initial potential of V_0 (less than V) which opposes the applied battery voltage V as shown in Fig. 5.37 (a).

As seen from Fig. 5.37 (b), the initial rate of rise of v_c is now somewhat less than when the capacitor is initially uncharged. Since the capacitor voltage rises from an initial value of v_0 to the final value of V in one time constant, its initial rate of rise is given by

$$\left(\frac{dv_c}{dt} \right)_{t=0} = \frac{V - V_0}{\lambda} = \frac{V - V_0}{RC}$$

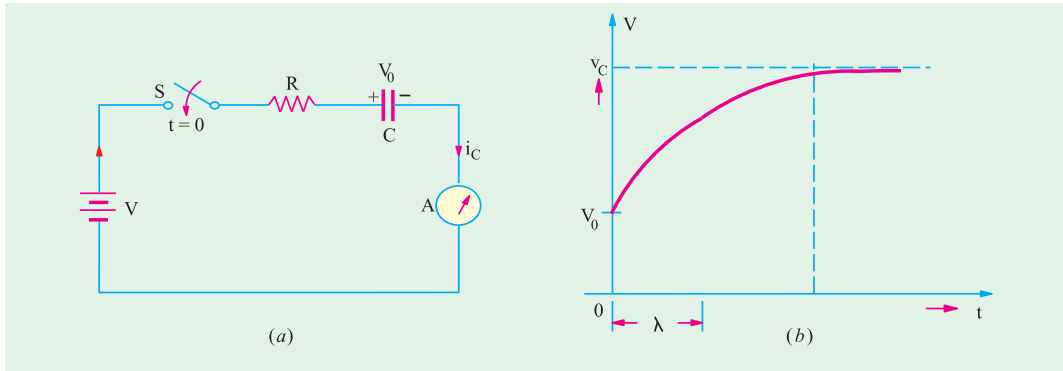

Fig. 5.37

The value of the capacitor voltage at *any time* during the charging cycle is given by

$$v_c = (V - V_0)(1 - e^{-t/\lambda}) + V_0$$

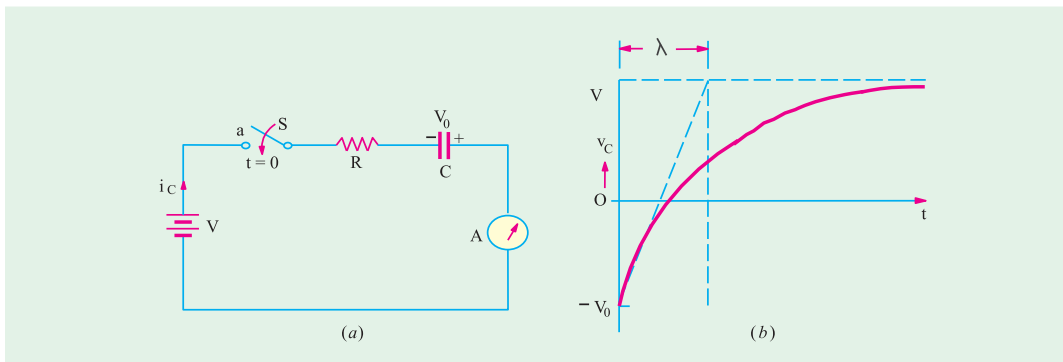

Fig. 5.38

However, as shown in Fig. 5.38 (a), if the initial capacitor voltage is negative with respect to the battery voltage *i.e.* the capacitor voltage is series aiding the battery voltage, rate of change of v_c is steeper than in the previous case. It is so because as shown in Fig. 5.38 (b), in one time period, the voltage change = $V - (-V_0) = (V + V_0)$. Hence, the initial rate of change of voltage is given by

$$\left(\frac{dv_c}{dt}\right)_{t=0} = \frac{V + V_0}{\lambda} = \frac{V + V_0}{RC}$$

The value of capacitor voltage at *any time* during the charging cycle is given by

$$v_c = (V + V_0)(1 - e^{-t/\lambda}) - V_0$$

The time required for the capacitor voltage to attain any value of v_c during the charging cycle is given by

$$t = \lambda \ln \left(\frac{V - V_0}{V - v_c} \right) = RC \ln \left(\frac{V - V_0}{V - v_c} \right) \quad \dots \text{when } V_0 \text{ is positive}$$

$$t = \lambda \ln \left(\frac{V + V_0}{V - v_c} \right) = RC \ln \left(\frac{V + V_0}{V - v_c} \right) \quad \dots \text{when } V_0 \text{ is negative}$$

Example 5.43. In Fig. 5.39, the capacitor is initially uncharged and the switch S is then closed. Find the values of I , I_1 , I_2 and the voltage at the point A at the start and finish of the transient state.

Solution. At the moment of closing the switch *i.e.* at the start of the transient state, the capacitor acts as a short-circuit. Hence, there is only a resistance of $2\ \Omega$ in the circuit because $1\ \Omega$ resistance is shorted out thereby grounding point *A*. Hence, $I_1 = 0$; $I = I_2 = 12/2 = 6\text{ A}$. Obviously, $V_A = 0\text{ V}$.

At the end of the transient state, the capacitor acts as an open-circuit. Hence,

$$I_2 = 0 \text{ and } I = I_1 = 12/(2 + 1) = 4\text{ A. } V_A = 6\text{ V.}$$

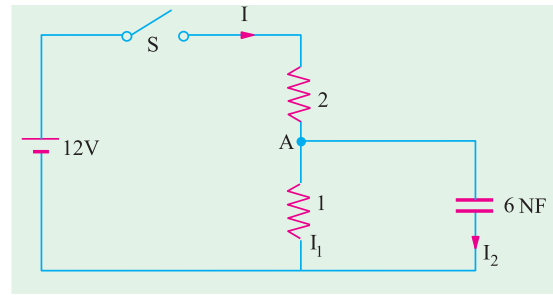

Fig. 5.39

Example 5.44. Calculate the values of $i_2, i_3, v_2, v_3, v_a, v_c$ and v_L of the network shown in Fig. 5.40 at the following times :

- (i) At time, $t = 0 +$ immediately after the switch *S* is closed ;
- (ii) At time, $t \rightarrow \infty$ *i.e.* in the steady state. (Network Analysis AMIE Sec. B Winter 1990)

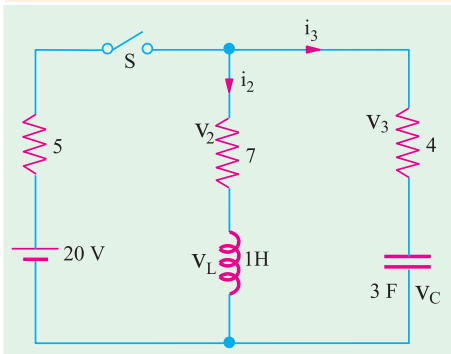

Fig. 5.40

Solution. (i) In this case the coil acts as an open circuit, hence $i_2 = 0$; $v_2 = 0$ and $v_L = 20\text{ V}$.

Since a capacitor acts as a short circuit $i_3 = 20/(5 + 4) = 9 = 20/9\text{ A}$. Hence, $v_3 = (20/9) \times 4 = 80/9\text{ V}$ and $v_c = 0$.

(ii) Under steady state conditions, capacitor acts as an open circuit and coil as a short circuit. Hence, $i_2 = 20/(5 + 7) = 20/12 = 5/3\text{ A}$; $v_2 = 7 \times 5/3 = 35/3\text{ V}$; $v_L = 0$. Also $i_3 = 0, v_3 = 0$ but $v_c = 20\text{ V}$.

Example 5.45. If in the RC circuit of Fig. 5.36; $R = 2\text{ M}\Omega, C = 5\text{ mF}$ and $V = 100\text{ V}$, calculate

- (a) initial rate of change of capacitor voltage
- (b) initial rate of change of capacitor current

- (c) initial rate of change of voltage across the $2\text{ M}\Omega$ resistor
- (d) all of the above at $t = 80\text{ s}$.

Solution. (a) $\left(\frac{dv_c}{dt}\right)_{t=0} = \frac{V}{2 \times 10^6} \frac{100}{5 \times 10^{-6}} \frac{100}{10} = 10\text{ V/s}$

(b) $\left(\frac{di_c}{dt}\right)_{t=0} = \frac{I_0}{10} \frac{V/R}{10} = \frac{100/2}{10} \frac{100}{10^6} = -5\mu\text{A/s}$

(c) $\left(\frac{dv_R}{dt}\right)_{t=0} = \frac{V}{10} \frac{100}{10} = -10\text{ V/s}$

(d) All the above rates of change would be zero because the transient disappears after about $5\lambda = 5 \times 10 = 50\text{ s}$.

Example 5.46. In Fig. 5.41 (a), the capacitor *C* is fully discharged, since the switch is in position 2. At time $t = 0$, the switch is shifted to position 1 for 2 seconds. It is then returned to position 2 where it remains indefinitely. Calculate

- (a) the maximum voltage to which the capacitor is charged when in position 1.
- (b) charging time constant λ_1 in position 1.
- (c) discharging time constant λ_2 in position 2.
- (d) v_c and i_c at the end of 1 second in position 1.

- (e) v_c and i_c at the instant the switch is shifted to position 2 at $t = 1$ second.
 (f) v_c and i_c after a lapse of 1 second when in position 2.
 (g) sketch the waveforms for v_c and i_c for the first 2 seconds of the above switching sequence.

Solution. (a) We will first find the voltage available at terminal 1. As seen the net battery voltage around the circuit = $40 - 10 = 30$ V. Drop across 30 K resistor = $30 \times 30/(30 + 60) = 10$ V. Hence, potential of terminal 1 with respect to ground $G = 40 - 10 = 30$ V. Hence, capacitor will charge to a maximum voltage of 30 V when in position 1.

(b) Total resistance, $R = [(30 \text{ K} \parallel 60 \text{ K}) + 10 \text{ K}] = 30 \text{ K}$

$\therefore \lambda_1 = RC = 30 \text{ K} \times 10 \mu\text{F} = 0.3 \text{ s}$

(c) $\lambda_2 = 10 \text{ K} \times 10 \mu\text{F} = 0.1 \text{ s}$

(d) $v_c = V(1 - e^{-t/\lambda_1}) = 30(1 - e^{-1/0.3}) = 28.9 \text{ V}$

$$i_c = \frac{V}{R} e^{-t/\lambda_1} = \frac{30 \text{ V}}{30 \text{ K}} e^{-1/0.3} = 1 \times 0.0361 = 0.036 \text{ mA}$$

(e) $v_c = 28.9 \text{ V}$ at $t = 1^+$ s at position 2 but $i_c = -28.9 \text{ V}/10 \text{ K} = -2.89 \text{ mA}$ at $t = 1^+$ s in position 2.

(f) $v_c = 28.9 e^{-t/\lambda_2} = 28.9 e^{-1/0.1} = 0.0013 \text{ V} \approx 0 \text{ V}$.

$$i_c = 28.9 e^{-t/\lambda_2} = -2.89 e^{-1/0.1} = 0.00013 \text{ mA} \approx 0.$$

The waveform of the capacitor voltage and charging current are sketched in Fig. 5.41 (b).

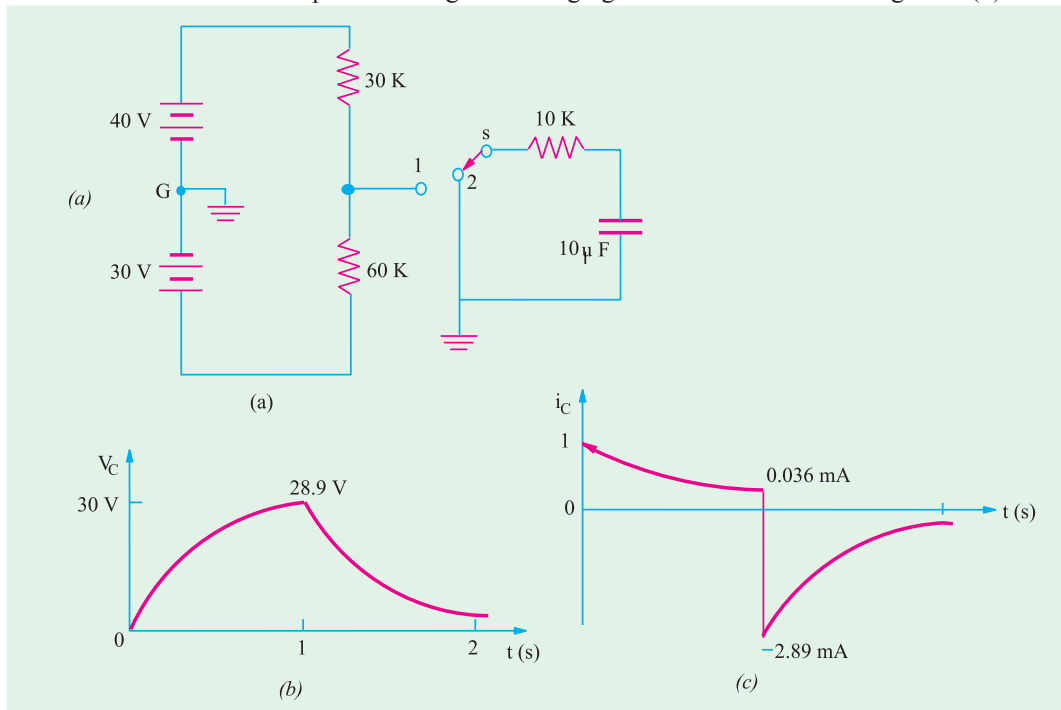

Fig. 5.41

Example 5.47. In the RC circuit of Fig. 5.42, $R = 2 \text{ M}\Omega$ and $C = 5 \mu\text{F}$, the capacitor is charged to an initial potential of 50 V . When the switch is closed at $t = 0^+$, calculate

- (a) initial rate of change of capacitor voltage and
 (b) capacitor voltage after a lapse of 5 times the time constant i.e. 5λ .

If the polarity of capacitor voltage is reversed, calculate

- (c) the values of the above quantities and
- (d) time for v_c to reach -10 V , 0 V and 95 V .

Solution. (a) $\left(\frac{dv_c}{dt}\right)_{t=0} = \frac{V - V_0}{\lambda}$
 $= \frac{V - V_0}{RC} = \frac{100 - 50}{10} = 5\text{ V/s}$

(b) $v_c = (V - V_0)(1 - e^{-t/\lambda}) + V_0$
 $= (100 - 50)(1 - e^{-5\lambda/\lambda}) = 50 = 49.7 + 50 = 99.7\text{ V}$

(c) When $V_0 = -50\text{ V}$, $\left(\frac{dv_c}{dt}\right)_{t=0} = \frac{V - (-V_0)}{\lambda} = \frac{V + V_0}{\lambda} = \frac{150}{10} = 15\text{ V/s}$

$v_c = (V - V_0)(1 - e^{-t/\lambda}) + V_0 = [100 - (-50)](1 - e^{-5}) + (-50)$
 $= 150(1 - e^{-5}) - 50 = 99\text{ V}$.

(d) $t = \lambda \ln\left(\frac{V - V_0}{V - v_c}\right) = 10 \ln\left[\frac{100 - (-50)}{100 - (-10)}\right] = 10 \ln\left(\frac{150}{110}\right) = 3.1\text{ s}$

$t = 10 \ln\left[\frac{100 - (-50)}{100 - (0)}\right] = 10 \ln\left(\frac{150}{100}\right) = 4.055\text{ s}$

$t = 10 \ln\left[\frac{100 - (-50)}{100 - 95}\right] = 10 \ln\left(\frac{150}{5}\right) = 34\text{ s}$

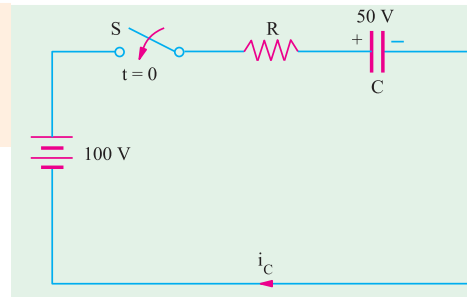

Fig. 5.42

Example 5.48. The uncharged capacitor, if it is initially switched to position 1 of the switch for 2 sec and then switched to position 2 for the next two seconds. What will be the voltage on the capacitor at the end of this period? Sketch the variation of voltage across the capacitor. [Bombay University 2001]

Solution. Uncharged capacitor is switched to position 1 for 2 seconds. It will be charged to 100 volts instantaneously since resistance is not present in the charging circuit. After 2 seconds, the capacitor charged to 100 volts will get discharged through R-C circuit with a time constant of

$\tau = RC = 1500 \times 10^{-3} = 1.5\text{ sec}$.

Counting time from instant of switching over to position 2, the expression for voltage across the capacitor is $V(t) = 100 \exp(-t/\tau)$

After 2 seconds in this position,

$v(t) = 100 \exp(-2/1.5) = 26/36\text{ Volts}$.

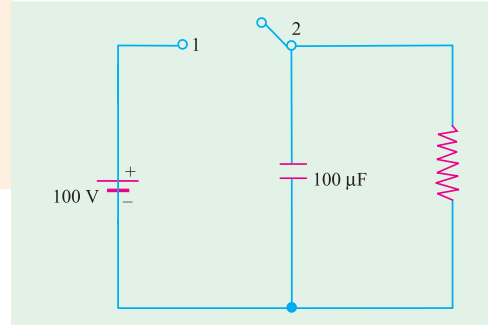

Fig. 5.43

Example 5.49. There are three passive elements in the circuit below and a voltage and a current are defined for each. Find the values of these six quantities at both $t = 0^-$ and $t = 0^+$.

[Bombay University, 2001]

Solution. Current source $4u(t)$ means a step function of 4 amp applied at $t = 0$. Other current source of 5 amp is operative throughout.

At $t = 0^-$, 5 amp source is operative. This unidirectional constant current establishes a steady current of 5 amp through 30-ohm resistor and 3-H inductor. Note that positive V_R means a rise from right to left.

At $t = 0$
 $V_R = -150$ Volts (Since right-terminal of Resistor is + ve)
 $i_L = 5$ amp
 $V_L = 0$, it represents the voltage between B and O .
 $i_C = 0$
 $V_C = 150$ volts $= V_{BO} +$ (Voltage between A and B with due regards to sign).
 $= 0 - (-150) = + 150$ volts

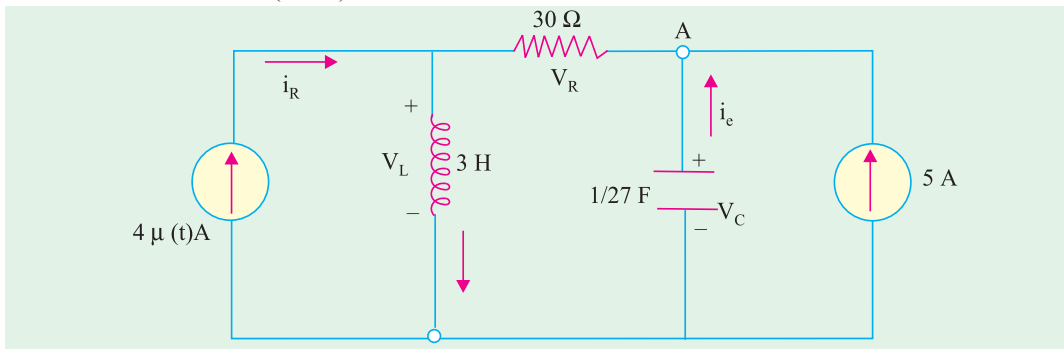

Fig. 5.44 (a)

At $t = 0_+$, 4 amp step function becomes operative. Capacitive-voltage and Inductance-current cannot change abruptly.

Hence $i_L(0_+) = 5$ amp

$V_C(0_+) = 150$ amp

$V_C(0_+) = 150$ volts, with node A positive with respect to O .

With these two values known, the waveforms for current sources are drawn in Fig. 5.44 (b).

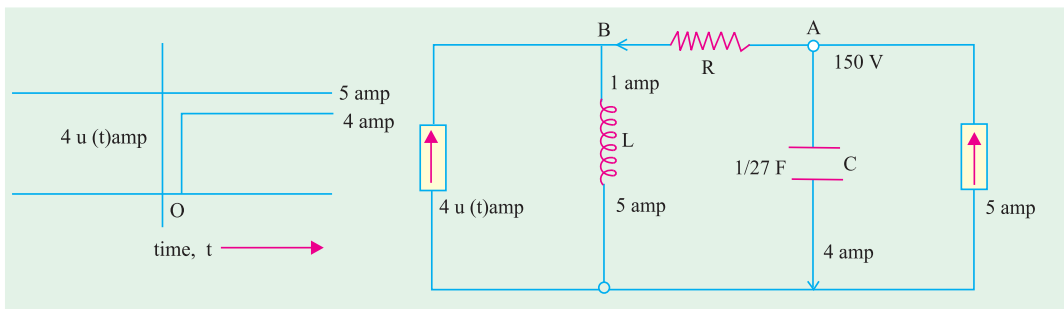

Fig. 5.44 (b)

Fig. 5.44 (c)

Remaining four parameters are evaluated from Fig. 5.44 (c).

$V_L = V_B = V_A - (30 \times 1) = 120$ Volts

$i_R = 1$ amp, $V_R = -30$ Volts

$i_C = 4$ amp in downward direction.

Additional Observation. After 4 amp source is operative, final conditions (at t tending to infinity) are as follows.

Inductance carries a total direct current of 9 amp, with $V_L = 0$.

Hence, $V_B = 0$.

$i_R = 5$ amp, $V_R = -150$ volts

$V_C = 150$ volts, $i_C = 0$

Example 5.50. The voltage as shown in Fig. 5.45 (a) is applied across **(i)** A resistor of 2 ohms **(ii)** A capacitor of 2 F. Find and sketch the current in each case up to 6 seconds.

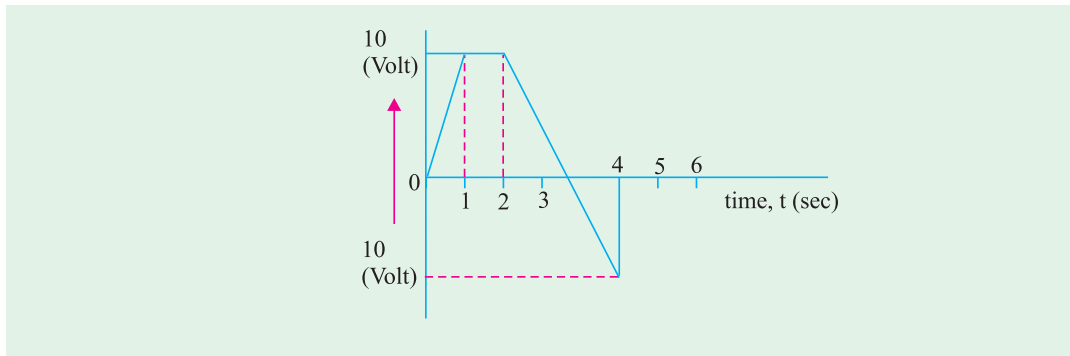

Fig. 5.45 (a)

[Bombay University 1998]

Solution.

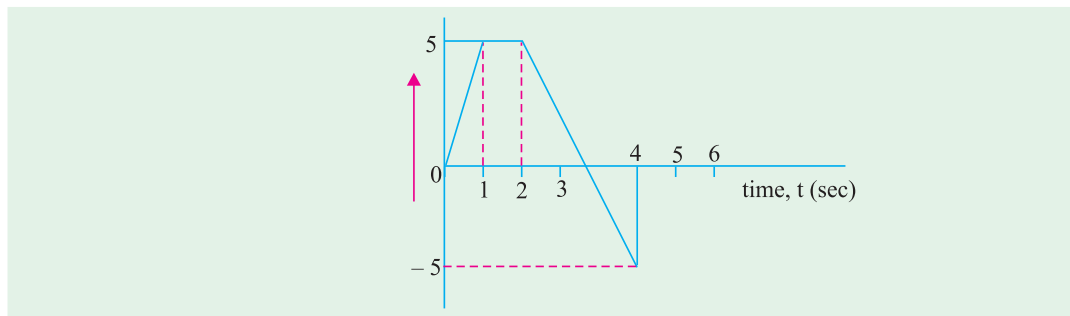

Fig. 5.45 (b) Current in a Resistor of 2 ohms $i_R = V(t)/2$ amp

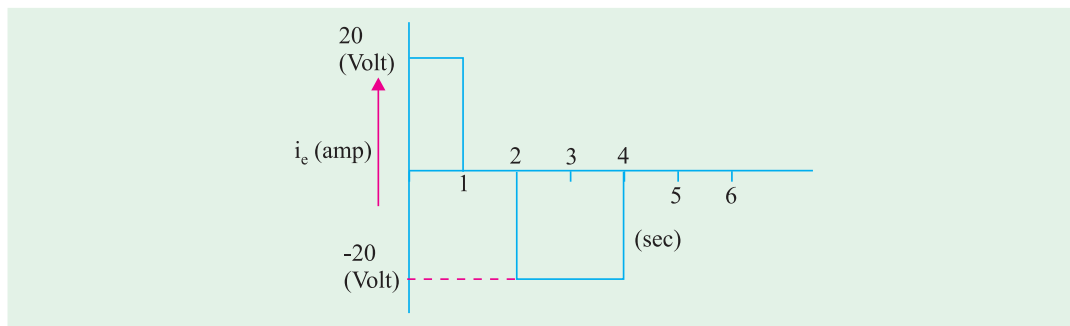

Fig. 5.45 (c) Current thro 2-F capacitor, $i_C = C (dv/dt)$

Example 5.51. Three capacitors $2 \mu F$, $3 \mu F$, and $5 \mu F$ are connected in series and charged from a $900 V$ d.c. supply. Find the voltage across condensers. They are then disconnected from the supply and reconnected with all the +ve plates connected together and all the -ve plates connected together. Find the voltages across the combinations and the charge on each capacitor after reconnections. Assume perfect insulation. [Bombay University, 1998]

Solution. The capacitors are connected in series. If C is the resultant capacitance.

$$1/C = 1/C_1 + 1/C_2 + 1/C_3, \text{ which gives } C = (30/31) \mu F$$

$$V_1 = 900 \times (30/31)/2 = 435.5 \text{ volts}$$

$$V_2 = 900 \times (30/31)/3 = 290.3 \text{ volts}$$

$$V_3 = 900 \times (30/31)/5 = 174.2 \text{ volts}$$

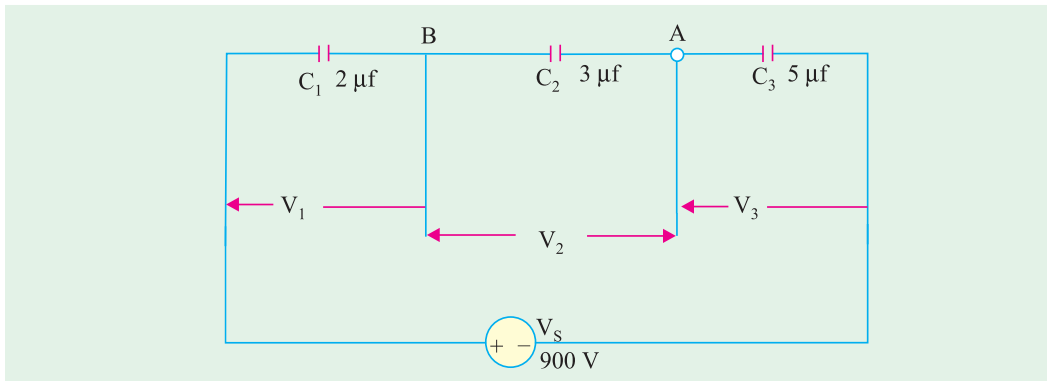

Fig. 5.46

In series connection, charge held by each capacitor is same. If it is denoted by Q .

$$Q = 435 \times 2 \times 10^{-6} = 871 \mu \text{ coulombs}$$

Three capacitors hold a total charge of $(3 \times 871) = 2613 \mu \text{ coulombs}$

With parallel connection of these three capacitors, equivalent capacitance, $C' = C_1 + C_2 + C_3 = 10 \mu\text{F}$

Since, $Q' = C', 2613 \times 10^{-6} = 10 \times 10^{-6} \times V'$

or $V' = 261 \text{ volts.}$

Charge on each capacitor after reconnection is as follows :

$$Q_1' = C_1 V_1 = 2 \times 10^{-6} \times 261 = \mathbf{522 \mu\text{-coulombs}}$$

$$Q_2' = C_2 V_1 = 3 \times 10^{-6} \times 261 = \mathbf{783 \mu\text{-coulombs}}$$

$$Q_3' = C_3 V_2 = 5 \times 10^{-6} \times 261 = \mathbf{1305 \mu\text{-coulombs}}$$

Tutorial Problems No. 5.3

- For the circuit shown in Fig. 5.47 calculate (i) equivalent capacitance and (ii) voltage drop across each capacitor. All capacitance values are in μF .

[(i) $6 \mu\text{F}$ (ii) $V_{AB} = 50 \text{ V}, V_{BC} = 40 \text{ V}$]

- In the circuit of Fig. 5.48 find (i) equivalent capacitance (ii) drop across each capacitor and (iii) charge on each capacitor. All capacitance values are in μF .

[(i) $1.82 \mu\text{F}$ (ii) $V_1 = 50 \text{ V}; V_2 = V_3 = 20 \text{ V}; V_4 = 40 \text{ V}$
(iii) $Q_1 = 200 \mu\text{C}; Q_2 = 160 \mu\text{C}; Q_3 = 40 \mu\text{C}; Q_4 = 200 \mu\text{C}$]

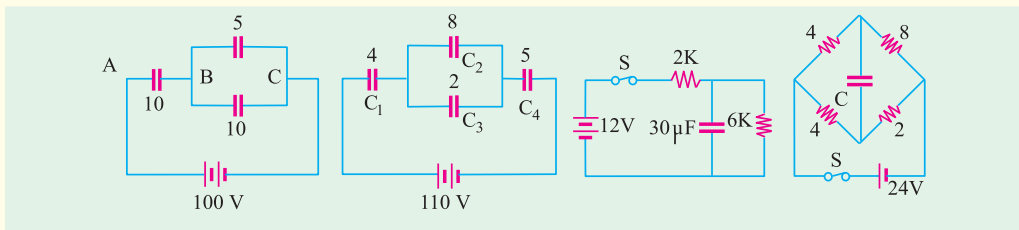

Fig. 5.47

Fig. 5.48

Fig. 5.49

Fig. 5.50

- With switch in Fig. 5.49 closed and steady-state conditions established, calculate (i) steady-state current (ii) voltage and charge across capacitor (iii) what would be the discharge current at the instant of opening the switch ?

[(i) 1.5 mA (ii) $9\text{V}; 270 \mu\text{C}$ (iii) 1.5 mA]

- When the circuit of Fig. 5.50 is in steady state, what would be the p.d. across the capacitor ? Also, find the discharge current at the instant S is opened.

[$8 \text{ V}; 1.8 \text{ A}$]

5. Find the time constant of the circuit shown in Fig. 5.51.

[200 μ S]

6. A capacitor of capacitance $0.01 \mu\text{F}$ is being charged by 1000 V d.c. supply through a resistor of 0.01 megaohm . Determine the voltage to which the capacitor has been charged when the charging current has decreased to 90% of its initial value. Find also the time taken for the current to decrease to 90% of its initial value.

[100 V, 0.1056 ms]

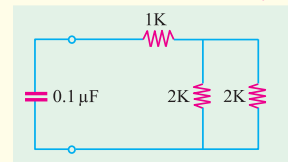

Fig. 5.51

7. An $8 \mu\text{F}$ capacitor is being charged by a 400 V supply through 0.1 mega-ohm resistor. How long will it take the capacitor to develop a p.d. of 300 V ? Also what fraction of the final energy is stored in the capacitor? [1.11 Second, 56.3% of full energy]

8. An $10 \mu\text{F}$ capacitor is charged from a 200 V battery 250 times/second and completely discharged through a 5Ω resistor during the interval between charges. Determine

(a) the power taken from the battery.

(b) the average value of the current in 5Ω resistor.

[(a) 50 W (b) 0.5 A]

9. When a capacitor, charged to a p.d. of 400 V , is connected to a voltmeter having a resistance of $25 \text{ M}\Omega$ the voltmeter reading is observed to have fallen to 50 V at the end of an interval of 2 minutes . Find the capacitance of the capacitor. [2.31 μF] (App. Elect. London Univ.)

10. A capacitor and a resistor are connected in series with a d.c. source of V volts. Derive an expression for the voltage across the capacitor after ' t ' seconds during discharging.

(Gujrat University, Summer 2003)

11. Derive an expression for the equivalent capacitance of a group of capacitors when they are connected (i) in parallel (ii) in series. (Gujrat University, Summer 2003)

12. The total capacitance of two capacitors is $0.03 \mu\text{F}$ when joined in series and $0.16 \mu\text{F}$ when connected in parallel. Calculate the capacitance of each capacitor. (Gujrat University, Summer 2003)

13. In a capacitor with two plates separated by an insulator 3 mm thick and of relative permittivity of 4 , the distance between the plates is increased to allow the insertion of a second insulator 5 mm thick and relative permittivity E . If the capacitance so formed is one third of the original capacitance, find E . (V.T.U., Belgaum Karnataka University, February 2002)

14. Derive an expression for the capacitance of a parallel plate capacitor.

(V.T.U., Belgaum Karnataka University, Summer 2002)

15. Three capacitors A, B and C are charged as follows

A = $10 \mu\text{F}$, 100 V B = $15 \mu\text{F}$, 150 V C = $25 \mu\text{F}$, 200 V

They are connected in parallel with terminals of like polarities together. Find the voltage across the combination. (V.T.U., Belgaum Karnataka University, Summer 2002)

16. Prove that average power consumed by a pure capacitance is zero.

(V.T.U., Belgaum Karnataka University, Summer 2002)

17. Current drawn by a pure capacitor of $20 \mu\text{F}$ is 1.382 A from 220 V AC supply. What is the supply frequency? (V.T.U., Belgaum Karnataka University, Summer 2003)

18. Find the equivalent capacitance between the points A and B of the network shown in fig. 1.

(V.T.U., Belgaum Karnataka University, Summer 2003)

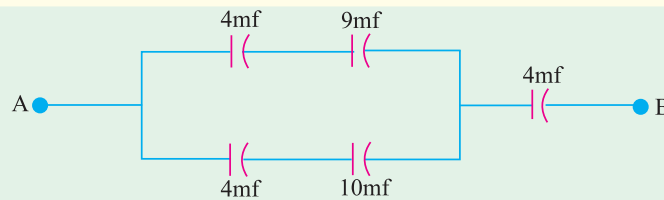

Fig. 5.52

19. Three capacitors of $1, 2$ and 3 micro farads are connected in series across a supply voltage of 100 V . Find the equivalent capacitance of the combination and energy stored in each capacitor. (Mumbai University 2003) (V.T.U. Belgaum Karnataka University, Wimter 2003)

20. Consider a parallel plate capacitor, the space between which is filled by two dielectric of thickness d_1 and d_2 with relative permittivities ϵ_1 and ϵ_2 respectively. Derive an expression for the capacitance between the plates. (V.T.U. Belgaum Karnataka University, Wimter 2004)

21. A capacitor consists of two plates of area $0.16m^2$ spaced 6mm apart. This space is filled with a layer of 1mm thick paper of relative permittivity 2, and remaining space with glass of relative permittivity 5. A dc voltage of 10kV is applied between the plates. Determine the electric field strength in each dielectric. (V.T.U. Belgaum Karnataka University, Winter2004)
22. In a give R-L circuit, $R = 35\Omega$ and $L = 0.1H$. Find (i) current through the circuit (ii) power factor if a 50 Hz frequency, voltage $V = 220\angle 30^\circ$ is applied across the circuit. (RGPV Bhopal 2001)
23. Three voltage represented by $e_1 = 20 \sin \omega t$, $e_2 = 30 \sin (\omega t + 45^\circ)$ and $e_3 = \sin (\omega t + 30^\circ)$ are connected in series and then connected to a load of impedance $(2 + j 3) \Omega$ Find the resultant current and power factor of the circuit. Draw the phasor diagram. (Mumbai University, 2002) (RGPV Bhopal 2001)

OBJECTIVE TESTS – 5

1. A capacitor consists of two
 (a) insulation separated by a dielectric
 (b) conductors separated by an insulator
 (c) ceramic plates and one mica disc
 (d) silver-coated insulators
2. The capacitance of a capacitor is NOT influenced by
 (a) plate thickness
 (b) plate area
 (c) plate separation
 (d) nature of the dielectric
3. A capacitor that stores a charge of 0.5 C at 10 volts has a capacitance offarad.
 (a) 5 (b) 20
 (c) 10 (d) 0.05
4. If dielectric slab of thickness 5 mm and $\epsilon_r = 6$ is inserted between the plates of an air capacitor with plate separation of 8 mm, its capacitance is
 (a) decreased (b) almost doubled
 (c) almost halved (d) unaffected
5. For the circuit shown in the given figure, the current through L and the voltage across C_2 are respectively

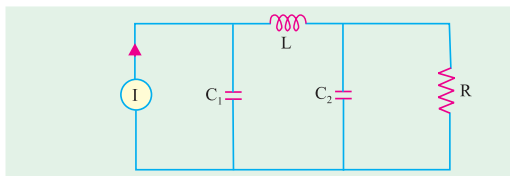

Fig. 5.53

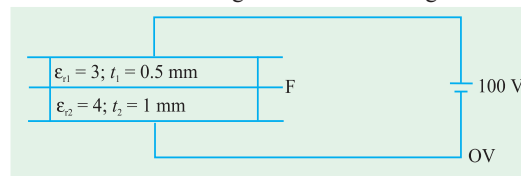

Fig. 5.54

- (a) 52 V (b) 60 V
 (c) 67 V (d) 33 V
 (GATE 2003)

ANSWERS

1. b 2. a 3. d 4. b