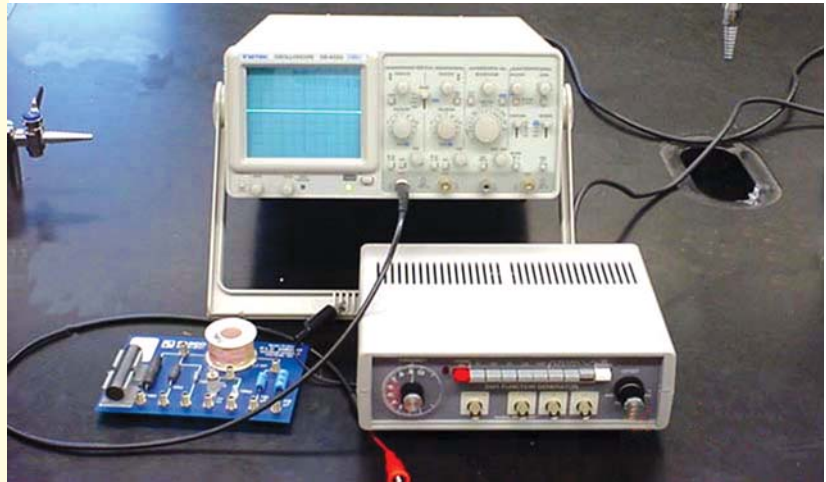

CHAPTER **14****Learning Objectives**

- Solving Parallel Circuits
- Vector or Phasor Method
- Admittance Method
- Application of Admittance Method
- Complex or Phasor Algebra
- Series-Parallel Circuits
- Series Equivalent of a Parallel Circuit
- Parallel Equivalent of a Series Circuit
- Resonance in Parallel Circuits
- Graphic Representation of Parallel Resonance
- Points to Remember
- Bandwidth of a Parallel Resonant Circuit
- Q-factor of a Parallel Circuit

**PARALLEL  
A.C.  
CIRCUITS**

- ↑ Parallel AC circuit combination is as important in power, radio and radar application as in series AC circuits

### 14.1. Solving Parallel Circuits

When impedances are joined in parallel, there are three methods available to solve such circuits:

(a) *Vector or phasor Method* (b) *Admittance Method* and (c) *Vector Algebra*

### 14.2. Vector or Phasor Method

Consider the circuits shown in Fig. 14.1. Here, two reactors *A* and *B* have been joined in parallel across an r.m.s. supply of *V* volts. The voltage across two parallel branches *A* and *B* is the same, but currents through them are different.

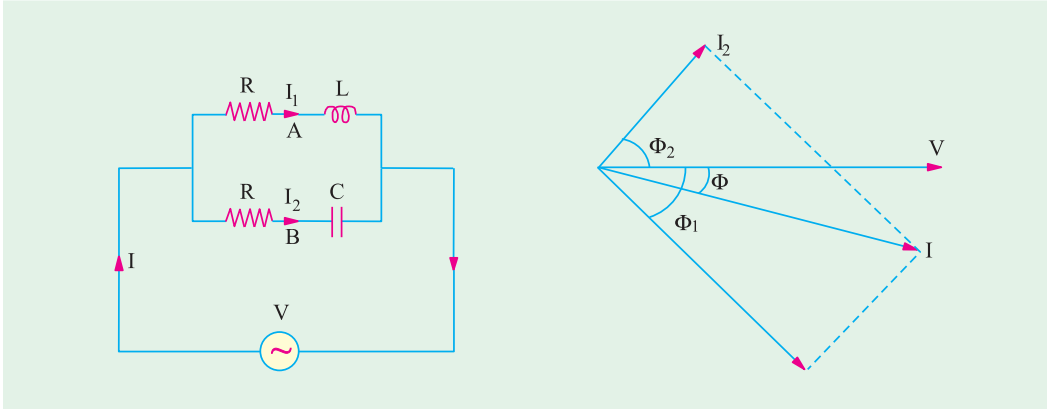

Fig. 14.1

Fig. 14.2

**For Branch A,**  $Z_1 = \sqrt{(R_1^2 + X_L^2)}$  ;  $I_1 = V/Z_1$  ;  $\cos \phi_1 = R_1/Z_1$  or  $\phi_1 = \cos^{-1} (R_1/Z_1)$

Current  $I_1$  lags behind the applied voltage by  $\phi_1$  (Fig. 14.2).

**For Branch B,**  $Z_2 = \sqrt{(R_2^2 + X_C^2)}$  ;  $I_2 = V/Z_2$  ;  $\cos \phi_2 = R_2/Z_2$  or  $\phi_2 = \cos^{-1} (R_2/Z_2)$

Current  $I_2$  leads  $V$  by  $\phi_2$  (Fig. 14.2).

#### Resultant Current *I*

The resultant circuit current  $I$  is the vector sum of the branch currents  $I_1$  and  $I_2$  and can be found by (i) using parallelogram law of vectors, as shown in Fig. 14.2. or (ii) resolving  $I_2$  into their X- and Y-components (or active and reactive components respectively) and then by combining these components, as shown in Fig. 14.3. Method (ii) is preferable, as it is quick and convenient.

With reference to Fig. 14.3. (a) we have

Sum of the active components of  $I_1$  and  $I_2$

$$= I_1 \cos \phi_1 + I_2 \cos \phi_2$$

Sum of the reactive components of  $I_1$  and  $I_2 = I_2 \sin \phi_2 - I_1 \sin \phi_1$

If  $I$  is the resultant current and  $\phi$  its phase, then its active and reactive components must be equal to these X- and Y-components respectively [Fig. 14.3. (b)]

$$I \cos \phi = I_1 \cos \phi_1 + I_2 \cos \phi_2 \text{ and } I \sin \phi = I_2 \sin \phi_2 - I_1 \sin \phi_1$$

$$\therefore I = \sqrt{[(I_1 \cos \phi_1 + I_2 \cos \phi_2)^2 + (I_2 \sin \phi_2 - I_1 \sin \phi_1)^2]}$$

and

$$\tan \phi = \frac{I_2 \sin \phi_2 - I_1 \sin \phi_1}{I_1 \cos \phi_1 + I_2 \cos \phi_2} = \frac{Y \text{ component}}{X \text{ component}}$$

If  $\tan \phi$  is positive, then current leads and if  $\tan \phi$  is negative, then current lags behind the applied

voltage  $V$ . Power factor for the whole circuit is given by

$$\cos \phi = \frac{I_1 \cos \phi_1 + I_2 \cos \phi_2}{I} \quad \frac{X \text{ comp.}}{I}$$

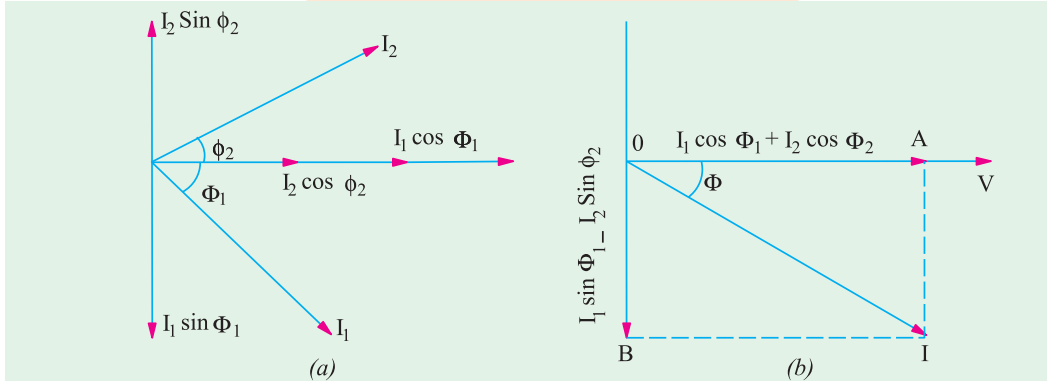

Fig. 14.3

### 14.3. Admittance Method

Admittance of a circuit is defined as *the reciprocal of its impedance*. Its symbol is  $Y$ .

$$\therefore Y = \frac{1}{Z} = \frac{I}{V} \text{ or } Y = \frac{\text{r.m.s. amperes}}{\text{r.m.s. volts}}$$

Its unit is Siemens ( $S$ ). A circuit having an impedance of one ohm has an admittance of one Siemens. The old unit was mho (ohm spelled backwards).

As the impedance  $Z$  of a circuit has two components  $X$  and  $R$  (Fig. 14.4.), similarly, admittance  $Y$  also has two components as shown in Fig. 14.5. The  $X$ -component is known as *conductance* and  $Y$ -component as *susceptance*.

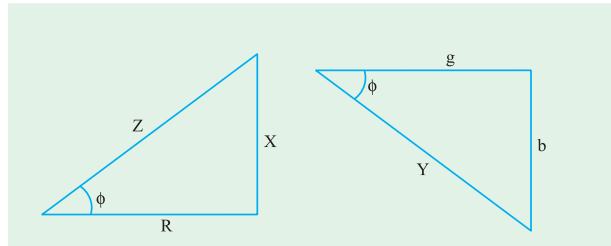

Fig. 14.4

Fig. 14.5

Obviously, conductance  $g = Y \cos \phi$

or  $g = \frac{1}{Z} \cdot \frac{R}{Z}$  (from Fig. 14.4)

$$\therefore g^* = \frac{R}{Z^2} = \frac{R}{R^2 + X^2}$$

Similarly, susceptance  $b = Y \sin \phi = \frac{1}{Z} \cdot \frac{X}{Z} \therefore b^{**} = \frac{X}{Z^2} = \frac{X}{R^2 + X^2}$  (from Fig. 14.5)

The admittance  $Y = \sqrt{(g^2 + b^2)}$  just as  $Z = \sqrt{(R^2 + X^2)}$

The unit of  $g$ ,  $b$  and  $Y$  is Siemens. We will regard the *capacitive susceptance as positive and inductive susceptance as negative*.

\* In the special case when  $X = 0$ , then  $g = 1/R$  i.e., conductance becomes reciprocal of resistance, not otherwise.

\*\* Similarly, in the special case when  $R = 0$ ,  $b = 1/X$  i.e., susceptance becomes reciprocal of reactance, not otherwise.

### 14.4. Application of Admittance Method

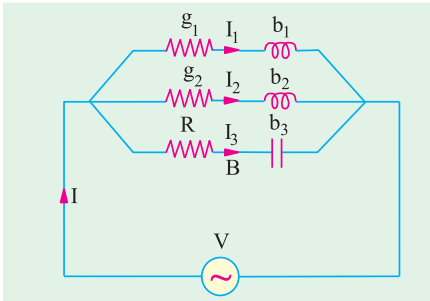

Fig. 14.6

Consider the 3-branched circuit of Fig. 14.6. Total conductance is found by merely adding the conductances of three branches. Similarly, total susceptance is found by *algebraically* adding the individual susceptances of different branches.

$$\text{Total conductance } G = g_1 + g_2 + g_3 \dots\dots\dots$$

$$\text{Total susceptance } B = (-b_1) + (-b_2) + b_3 \dots\dots \quad (\text{algebraic sum})$$

$$\therefore \text{ Total admittance } Y = \sqrt{(G^2 + B^2)}$$

$$\text{Total current } I = VY ; \text{ Power factor } \cos \phi = G/Y$$

### 14.5. Complex or Phasor Algebra

Consider the parallel circuit shown in Fig. 14.7. The two impedances,  $Z_1$  and  $Z_2$ , being in parallel, have the same p.d. across them.

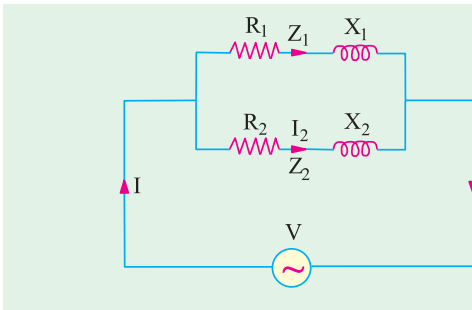

Fig. 14.7

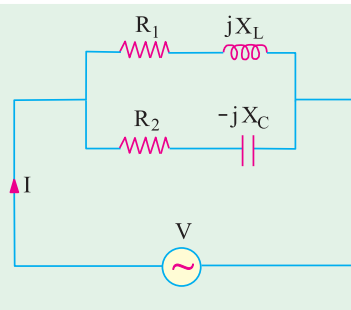

Fig. 14.8

$$\text{Now} \quad I_1 = \frac{V}{Z_1} \text{ and } I_2 = \frac{V}{Z_2}$$

$$\text{Total current} \quad I = I_1 + I_2 = \frac{V}{Z_1} + \frac{V}{Z_2} = V \left( \frac{1}{Z_1} + \frac{1}{Z_2} \right) = V(Y_1 + Y_2) = VY$$

where

$$Y = \text{total admittance} = Y_1 + Y_2$$

It should be noted that *admittances are added* for parallel branches, whereas for branches in series, it is the *impedances* which are *added*. *However, it is important to remember that since both admittances and impedances are complex quantities, all additions must be in complex form.* Simple arithmetic additions must not be attempted.

Considering the two parallel branches of Fig. 14.8, we have

$$\begin{aligned} Y_1 &= \frac{1}{Z_1} = \frac{1}{R_1 + jX_L} = \frac{(R_1 - jX_L)}{(R_1 + jX_L)(R_1 - jX_L)} \\ &= \frac{R_1}{R_1^2 + X_L^2} - j \frac{X_L}{R_1^2 + X_L^2} \quad g_1 \quad jb_1 \end{aligned}$$

$$\text{where} \quad g_1 = \frac{R_1}{R_1^2 + X_L^2} - \text{conductance of upper branch,}$$

$$b_1 = -\frac{X_L}{R_1^2 + X_L^2} - \text{susceptance of upper branch}$$

Similarly,  $Y_2 = \frac{1}{Z_2} = \frac{1}{R_2 - jX_C}$   
 $= \frac{R_2 + jX_C}{(R_2 - jX_C)(R_2 + jX_C)} = \frac{R_2 + jX_C}{R_2^2 + X_C^2} = \frac{R_2}{R_2^2 + X_C^2} + j \frac{X_C}{R_2^2 + X_C^2} = g_2 + jb_2$

Total admittance  $Y = Y_1 + Y_2 = (g_1 - jb_1) + (g_2 + jb_2) = (g_1 + g_2) - j(b_1 - b_2) = G - jB$

$$Y = \sqrt{[(g_1 + g_2)^2 + (b_1 - b_2)^2]}; \phi = \tan^{-1} \frac{b_1 - b_2}{g_1 + g_2}$$

The polar form for admittance is  $Y = Y \angle \phi^\circ$  where  $\phi$  is as given above.

$$Y = \sqrt{G^2 + B^2} \angle \tan^{-1} (B/G)$$

Total current  $I = VY$ ;  $I_1 = VY_1$  and  $I_2 = VY_2$

If  $V = V \angle 0^\circ$  and  $Y = Y \angle \phi$  then  $I = VY = V \angle 0^\circ \times Y \angle \phi = VY \angle \phi$

In general, if  $V = V \angle \alpha$  and  $Y = Y \angle \beta$ , then  $I = VY = V \angle \alpha \times Y \angle \beta = VY \angle \alpha + \beta$

Hence, it should be noted that when vector voltage is multiplied by admittance either in complex (rectangular) or polar form, the result is vector current in its proper phase relationship with respect to the voltage, **regardless of the axis to which the voltage may have been referred to.**

**Example 14.1.** Two circuits, the impedance of which are given by  $Z_1 = 10 + j15$  and  $Z_2 = 6 - j8$  ohm are connected in parallel. If the total current supplied is 15 A, what is the power taken by each branch? Find also the p.f. of individual circuits and of combination. Draw vector diagram.

(Elect. Technology, Vikram Univ, Ujjain)

**Solution.** Let  $I = 15 \angle 0^\circ$ ;  $Z_1 = 10 + j15 = 18 \angle 57^\circ$

$$Z_2 = 6 - j8 = 10 \angle -53.1^\circ$$

Total impedance,  $Z = \frac{Z_1 Z_2}{Z_1 + Z_2} = \frac{(10 + j15)(6 - j8)}{16 + j7}$   
 $= 9.67 - j3.6 = 10.3 \angle -20.4^\circ$

Applied voltage is given by

$$V = IZ = 15 \angle 0^\circ \times 10.3 \angle -20.4^\circ = 154.4 \angle -20.4^\circ$$

$$I_1 = V/Z_1 = 154.4 \angle -20.4^\circ / 18 \angle 57^\circ = 8.58 \angle -77.4^\circ$$

$$I_2 = V/Z_2 = 154.4 \angle -20.4^\circ / 10 \angle -53.1^\circ = 15.45 \angle 32.7^\circ$$

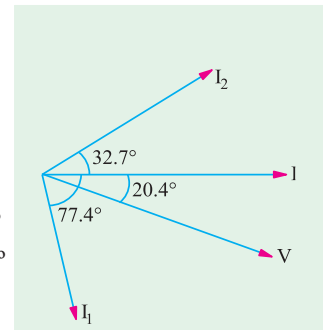

Fig. 14.9

We could also find branch currents as under :

$$I_1 = I \cdot Z_2 / (Z_1 + Z_2) \text{ and } I_2 = I \cdot Z_1 / (Z_1 + Z_2)$$

It is seen from phasor diagram of Fig. 14.9 that  $I_1$  lags behind  $V$  by  $(77.4^\circ - 20.4^\circ) = 57^\circ$  and  $I_2$  leads it by  $(32.7^\circ + 20.4^\circ) = 53.1^\circ$ .

$$\therefore P_1 = I_1^2 R_1 = 8.58^2 \times 10 = 736 \text{ W}; \text{ p.f.} = \cos 57^\circ = 0.544 \text{ (lag)}$$

$$P_2 = I_2^2 R_2 = 15.45^2 \times 6 = 1432 \text{ W}; \text{ p.f.} = \cos 53.1^\circ = 0.6$$

Combined p.f. =  $\cos 20.4^\circ = 0.937$  (lead)

**Example 14.2.** Two impedance  $Z_1 = (8 + j6)$  and  $Z_2 = (3 - j4)$  are in parallel. If the total current of the combination is 25 A, find the current taken and power consumed by each impedance.

(F.Y. Engg. Pune Univ.)

**Solution.**  $Z_1 = (8 + j6) = 10 \angle 36.87^\circ$ ;  $Z_2 = (3 - j4) = 5 \angle -53.1^\circ$

$$Z = \frac{Z_1 Z_2}{Z_1 + Z_2} = \frac{(10 \angle 36.87^\circ)(5 \angle -53.1^\circ)}{(8 + j6) + (3 - j4)} = \frac{50 \angle -16.23^\circ}{11 + j2} = \frac{50 \angle -16.23^\circ}{11.18 \angle 10.3^\circ} = 4.47 \angle -26.53^\circ$$

Let  $I = 25 \angle 0^\circ$ ;  $V = IZ = 25 \angle 0^\circ \times 4.47 \angle -26.53^\circ = 111.75 \angle -26.53^\circ$

$$I_1 = V/Z_1 = 111.75 \angle -26.53^\circ / 10 \angle 36.87^\circ = 11.175 \angle -63.4^\circ$$

$$I_2 = 111.75 \angle -26.53^\circ / 5 \angle -53.1^\circ = 22.35 \angle 26.57^\circ$$

Now, the phase difference between  $V$  and  $I_1$  is  $63.4^\circ - 26.53^\circ = 36.87^\circ$  with current lagging. Hence,  $\cos \phi_1 = \cos 36.87^\circ = 0.8$ .

$$\text{Power consumed in } Z_1 = VI_1 \cos \phi = 111.75 \times 11.175 \times 0.8 = \mathbf{990 \text{ W}}$$

$$\text{Similarly, } \phi_2 = 26.57^\circ - (-26.53^\circ) = 53.1^\circ; \cos 53.1^\circ = 0.6$$

$$\text{Power consumed in } Z_2 = VI_2 \cos \phi_2 = 111.75 \times 22.35 \times 0.6 = \mathbf{1499 \text{ W}}$$

**Example 14.3.** Refer to the circuit of Fig. 14.10 (a) and determine the resistance and reactance of the lagging coil load and the power factor of the combination when the currents are as indicated.

(Elect. Engg. A.M.Ae. S.I.)

**Solution.** As seen from the  $\Delta ABC$  of Fig. 14.10 (b).

$$5.6^2 = 2^2 + 4.5^2 + 2 \times 2 \times 4.5 \times \cos \theta, \therefore \cos \theta = 0.395, \sin \theta = 0.919. Z = 300/4.5 = 66.67 \Omega$$

$$R = Z \cos \theta = 66.67 \times 0.395 = 61.3 \Omega$$

$$\text{p.f.} = \cos \phi = AC/AD = (2 + 4.5 \times 0.395)/5.6 = \mathbf{0.67 \text{ (lag)}}$$

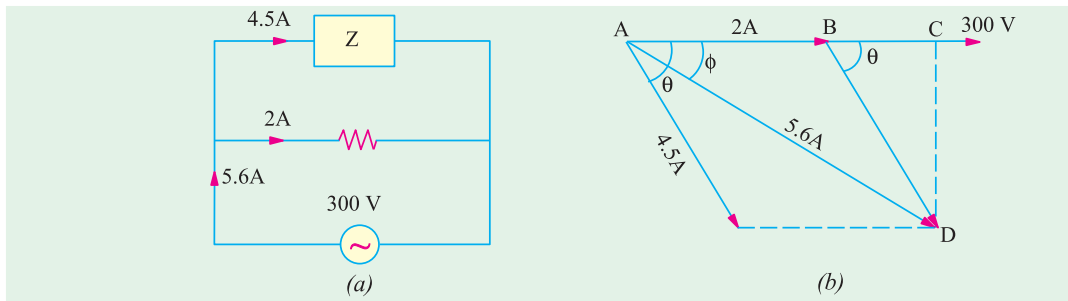

Fig. 14.10

**Example 14.4.** A mercury vapour lamp unit consists of a  $25 \mu\text{f}$  condenser in parallel with a series circuit containing the resistive lamp and a reactor of negligible resistance. The whole unit takes  $400 \text{ W}$  at  $240 \text{ V}$ ,  $50 \text{ Hz}$  at unity p.f. What is the voltage across the lamp?

(F.Y. Engg. Pune Univ.)

$$\text{Solution. } X_C = \frac{1}{2\pi f C} = \frac{1}{2\pi \times 50 \times (25 \times 10^{-6})} = 127.3 \Omega, \therefore I_C = \frac{240}{127.3} = 1.885 \text{ A}$$

$$W = VI \cos \phi = VI \quad \therefore I = W/V = 400/240 = 1.667 \text{ A}$$

In the vector diagram of Fig. 14.10 (b)  $I_C$  leads  $V$  by  $90^\circ$  and current  $I_1$  in the series circuit lags  $V$  by  $\phi_1$  where  $\phi_1$  is the power factor angle of the series circuit. The vector sum of  $I_C$  and  $\phi_1$  gives the total current  $I$ . As seen  $\tan \phi_1 = I_C/I = 1.885/1.667 = 1.13077$ . Hence,  $\phi_1 = 48.5^\circ$  lag. The applied voltage  $V$  is the vector sum of the drop across the resistive lamp which is in phase with  $I_1$  and drop across the coil which leads  $I_1$  by  $90^\circ$ .

$$\text{Voltage across the lamp} = V \cos \Phi_1 = 340 \times \cos 48.5 = 240 \times 0.662 = \mathbf{159 \text{ V.}}$$

**Example 14.5.** The currents in each branch of a two-branched parallel circuit are given by the expression  $i_a = 7.07 \sin (314t - \pi/4)$  and  $i_b = 21.2 \sin (314t + \pi/3)$

The supply voltage is given by the expression  $v = 354 \sin 314t$ . Derive a similar expression for the supply current and calculate the ohmic value of the component, assuming two pure components in each branch. State whether the reactive components are inductive or capacitive.

(Elect. Engineering., Calcutta Univ.)

**Solution.** By inspection, we find that  $i_a$  lags the voltage by  $\pi/4$  radian or  $45^\circ$  and  $i_b$  leads it by  $\pi/3$  radian or  $60^\circ$ . Hence, branch A consists of a resistance in series with a pure inductive reactance. Branch B consists of a resistance in series with pure capacitive reactance as shown in Fig. 14.11 (a).

Maximum value of current in branch A is 7.07 A and in branch B is 21.2 A. The resultant current can be found vectorially. As seen from vector diagram.

$$X\text{-comp} = 21.2 \cos 60^\circ + 7.07 \cos 45^\circ = 15.6 \text{ A}$$

$$Y\text{-comp} = 21.2 \sin 60^\circ - 7.07 \sin 45^\circ = 13.36 \text{ A}$$

$$\text{Maximum value of the resultant current is} = \sqrt{15.6^2 + 13.36^2} = 20.55 \text{ A}$$

$$\phi = \tan^{-1} (13.36/15.6) = \tan^{-1} (0.856) = 40.5^\circ \text{ (lead)}$$

Hence, the expression for the supply current is  $i = 20.55 \sin (314 t + 40.5^\circ)$

$$Z_A = 354/7.07 = 50 \Omega; \cos \phi_A = \cos 45^\circ$$

$$= 1/\sqrt{2} \cdot \sin \phi_A = \sin 45^\circ = 1/\sqrt{2}$$

$$R_A = Z_A \cos \phi_A = 50 \times 1/\sqrt{2} = 35.4 \Omega$$

$$X_L = Z_A \sin \phi_A = 50 \times 1/\sqrt{2} = 35.4 \Omega$$

$$Z_B = 354/20.2 = 17.5 \Omega$$

$$R_B = 17.5 \times \cos 60^\circ = 8.75 \Omega$$

$$X_C = 17.5 \times \sin 60^\circ = 15.16 \Omega$$

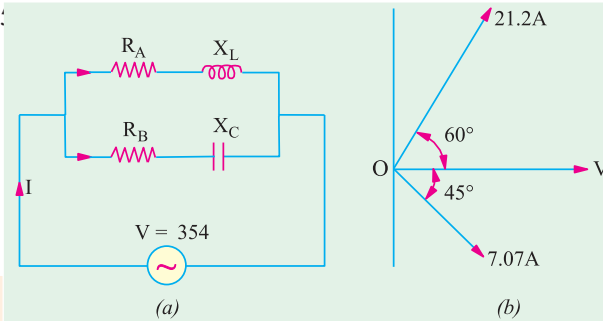

Fig. 14.11

**Example 14.5 (a).** A total current of 10 A flows through the parallel combination of three impedance :  $(2 - j5) \Omega$   $(6 + j3) \Omega$  and  $(3 + j4) \Omega$  Calculate the current flowing through each branch. Find also the p.f. of the combination.

(Elect. Engg., -I Delhi Univ.)

**Solution.** Let  $Z_1 = (2 - j5)$ ,  $Z_2 = (6 + j3)$ ,  $Z_3 = (3 + j4)$

$$Z_1 Z_2 = (2 - j5)(6 + j3) = 27 - j24. \quad Z_2 Z_3 = (6 + j3)(3 + j4) = 6 + j33$$

$$Z_3 Z_1 = (3 + j4)(2 - j5) = 26 - j7; \quad Z_1 Z_2 + Z_2 Z_3 + Z_3 Z_1 = 59 + j2$$

With reference to Art, 1.25

$$I_1 = I \cdot \frac{Z_2 Z_3}{Z_1 Z_2 + Z_2 Z_3 + Z_3 Z_1} = (10 - j0) \frac{6 + j33}{59 + j2} = 1.21 - j5.55$$

$$I_2 = I \cdot \frac{Z_3 Z_1}{Z_1 Z_2 + Z_2 Z_3 + Z_3 Z_1} = (10 - j0) \frac{26 - j7}{59 + j2} = 4.36 + j1.33$$

$$I_3 = I \cdot \frac{Z_1 Z_2}{Z_1 Z_2 + Z_2 Z_3 + Z_3 Z_1} = (10 - j0) \frac{27 - j24}{59 + j2} = 4.43 - j4.22$$

$$\text{Now, } Z = \frac{Z_1 Z_2 Z_3}{Z_1 Z_2 + Z_2 Z_3 + Z_3 Z_1} = \frac{(2 - j5)(6 + j3)(3 + j4)}{59 + j2} = 3.01 - j0.51$$

$$V = 10 \angle 0^\circ \times 3.05 \angle 9.6^\circ = 30.5 \angle 9.6^\circ$$

Combination p.f. =  $\cos 9.6^\circ = 0.986$  (lag)

**Example 14.6.** Two impedances given by  $Z_1 = (10 + j5)$  and  $Z_2 = (8 + j6)$  are joined in parallel and connected across a voltage of  $V = 200 + j0$ . Calculate the circuit current, its phase and the branch currents. Draw the vector diagram.

(Electrotechnics-I, M.S. Univ. Baroda)

**Solution.** The circuit is shown in Fig. 14.12

$$\text{Branch A, } Y_1 = \frac{1}{Z_1} = \frac{1}{(10 + j5)}$$

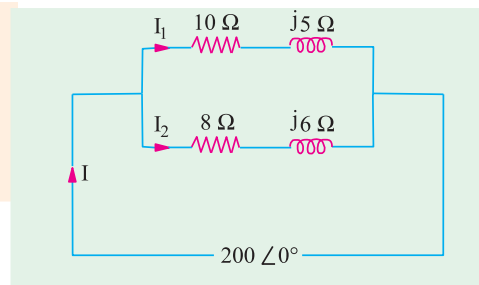

Fig. 14.12

$$= \frac{10 - j5}{(10 + j5)(10 - j5)} = \frac{10 - j5}{100 + 25}$$

$$= 0.08 - j0.04 \text{ Siemens}$$

$$\text{Branch B, } Y_2 = \frac{1}{Z_2} = \frac{1}{(8 + j6)}$$

$$= \frac{8 - j6}{(8 + j6)(8 - j6)} = \frac{8 - j6}{64 + 36} = 0.08 - j0.06 \text{ Siemens}$$

$$Y = (0.08 - j0.04) + (0.08 - j0.06) = 0.16 - j0.1 \text{ Siemens}$$

### Direct Method

We could have found total impedance straightway like this:  $\frac{1}{Z} = \frac{1}{Z_1} + \frac{1}{Z_2} = \frac{Z_1 + Z_2}{Z_1 Z_2}$

$$\therefore Y = \frac{Z_1 + Z_2}{Z_1 Z_2} = \frac{(10 - j5) + (8 - j6)}{(10 - j5)(8 - j6)} = \frac{18 - j11}{50 - j100}$$

Rationalizing the above, we get

$$Y = \frac{(18 - j11)(50 + j100)}{(50 - j100)(50 + j100)} = \frac{200 - j1250}{12,500} = 0.16 - j0.1 \text{ (same as before)}$$

Now  $V = 200 \angle 0^\circ = 200 + j0$

$$\therefore I = VY = (200 + j0)(0.16 - j0.1)$$

$$= 32 - j20 = 37.74 \angle 32^\circ \dots \text{polar form}$$

Power factor =  $\cos 32^\circ = 0.848$

$$I_1 = VY_1 = (200 + j0)(0.08 - j0.04)$$

$$= 16 - j8 = 17.88 \angle 26^\circ 32'$$

It lags behind the applied voltage by  $26^\circ 32'$ .

$$I_2 = VY_2 = (200 + j0)(0.08 - j0.06)$$

$$= 16 - j12 = 20 \angle 36^\circ 46'$$

It lags behind the applied voltage by  $36^\circ 46'$ . The vector diagram is shown in Fig. 14.13.

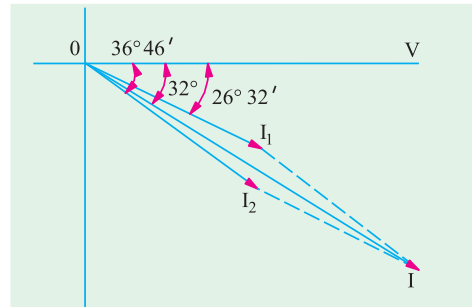

Fig. 14.13

**Example 14.7.** Explain the term admittance. Two impedance  $Z_1 = (6 - j8)$  ohm and  $Z_2 = (16 + j12)$  ohm are connected in parallel. If the total current of the combination is  $(20 + j10)$  amperes, find the complexor for power taken by each impedance. Draw and explain the complete phasor diagram. (Basic Electricity, Bombay Univ.)

**Solution.** Let us first find out the applied voltage,  $Y = Y_1 + Y_2 = \frac{1}{6 - j8} + \frac{1}{16 + j12}$

$$= (0.06 + j0.08) + (0.04 - j0.03) = 0.1 + j0.05 = 0.1118 \angle 26^\circ 34'$$

$$I = 20 + j10 = 22.36 \angle 26^\circ 34'$$

Now  $I = VY \therefore V = \frac{I}{Y} = \frac{22.36 \angle 26^\circ 34'}{0.1118 \angle 26^\circ 34'} = 200 \angle 0^\circ$

$$I_1 = VY_1 = (200 + j0)(0.06 + j0.008) = 12j + 16 \text{ A, } I_2 = 200(0.04 - j0.03) = 8 - j6 \text{ A}$$

Using the method of conjugates and taking voltage conjugate, the complexor power taken by each branch can be found as under:

$$P_1 = (200 - j0)(12 + j16) = 2400 + j3200; P_2 = (200 - j0)(8 - j6) = 100 - j1200$$

Drawing of phasor diagram is left to the reader.

**Note.** Total voltamperes =  $4000 + j2000$

As a check,  $P = VI = 200(20 + j10) = 4000 + j2000$

**Example 14.8.** A 15-mH inductor is in series with a parallel combination of an 80 Ω resistor and 20 μF capacitor. If the angular frequency of the applied voltage is  $\omega = 1000$  rad/s, find the admittance of the network. **(Basic Circuit Analysis Osmania Univ. Jan/Feb 1992)**

**Solution.**  $X_L = \omega L = 1000 \times 15 \times 10^{-3} = 15\Omega$ ;  $X_C = 1/\omega C = 10^6/1000 \times 20 = 50 \Omega$   
 Impedance of the parallel combination is given by  
 $Z_p = 80 \parallel -j 50 = -j4000/(80 - j50) = 22.5 - j36$ ,  
 Total impedance =  $j15 + 22.5 - j36 = 22.5 - j21$   
 Admittance  $Y = \frac{1}{Z} = \frac{1}{22.5 - j21} = 0.0238 + j0.022$  Siemens

**Example 14.9.** An impedance  $(6 + j 8)$  is connected across 200-V, 50-Hz mains in parallel with another circuit having an impedance of  $(8 - j6) \Omega$ . Calculate (a) the admittance, the conductance, the susceptance of the combined circuit (b) the total current taken from the mains and its p.f. **(Elect. Engg-AMIE, S.I. 1992)**

**Solution.**  $Y_1 = \frac{1}{6 + j8} = \frac{6 - j8}{6^2 + 8^2} = 0.06 - j0.08$  Siemens,  $Y = \frac{1}{8 - j6} = \frac{8 + j6}{100} = 0.08 + j0.06$

Siemens

(a) Combined admittance is  $Y = Y_1 + Y_2 = 0.14 - j0.02 = 0.1414 \angle -88^\circ$  Siemens  
 Conductance,  $G = 0.14$  Siemens ; Susceptance,  $B = -0.02$  Siemens (inductive)  
 (b) Let  $V = 200 \angle 0^\circ$  ;  $I = VY = 200 \times 0.1414 \angle -88^\circ$   $V = 28.3 \angle -88^\circ$   
 p.f. =  $\cos 88^\circ = 0.99$  (lag)

**Example 14.10.** If the voltmeter in Fig. 14.14 reads 60 V, find the reading of the ammeter.

**Solution.**  $I_2 = 60/4 = 15$  A. Taking it as reference quantity, we have  $I_2 = 15 \angle 0$ .

Obviously, the applied voltage is

$$V = 15 \angle 0^\circ \times (4 - j4) = 84.8 \angle 45^\circ$$

$$I_1 = 84.8 \angle 45^\circ / (6 + j3) = 84.8 \angle 45^\circ / 6.7 \angle 26.6^\circ = 12.6 \angle 71.6^\circ = (4 - j12)$$

$$I = I_1 + I_2 = (15 + j0) + (4 - j12) = 19 - j12 = 22.47 \angle -32.3^\circ$$

Hence, ammeter reads 22.47.

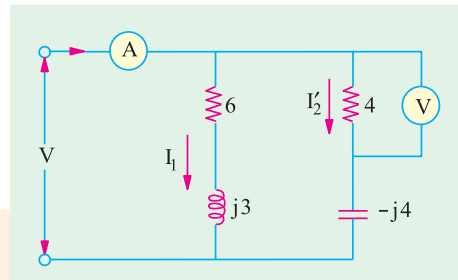

Fig. 14.14

**Example 14.11.** Find the reading of the ammeter when the voltmeter across the 3 ohm resistor in the circuit of Fig. 14.15 reads 45 V.

**(Elect. Engg. & Electronics Bangalore Univ. )**

**Solution.** Obviously  $I_1 = 45/3 = 15$  A. If we take it as reference quantity,  $I_1 = 3 \angle 0^\circ$

$$\text{Now, } Z_1 = 3 - j3 = 4.24 \angle -45^\circ.$$

$$\text{Hence, } V = I_1 Z_1 = 15 \angle 0^\circ \times 4.24 \angle -45^\circ = 63.6 \angle -45^\circ$$

$$I_2 = \frac{V}{Z_2} = \frac{63.6 \angle -45^\circ}{5 + j2} = \frac{63.6 \angle -45^\circ}{5.4 \angle 21.8^\circ}$$

$$= 11.77 \angle -66.8^\circ = 4.64 - j10.8$$

$$I = I_1 + I_2 = 19.64 - j10.8 = 22.4 \angle -28.8^\circ$$

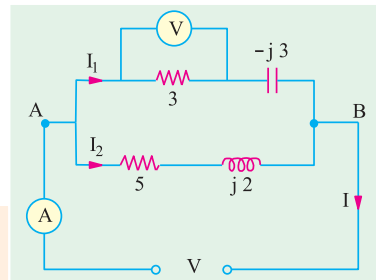

Fig. 14.15

**Example 14.12.** A coil having a resistance of 5 Ω and an inductance of 0.02 H is arranged in parallel with another coil having a resistance of 1 Ω and an inductance of 0.08 H. Calculate the current through the combination and the power absorbed when a voltage of 100 V at 50 Hz is applied. Estimate the resistance of a single coil which will take the same current at the same power factor.

**Solution.** The circuit and its phasor diagram are shown in Fig. 14.16.

**Branch No. 1**

$$X_1 = 314 \times 0.02 = 6.28 \Omega$$

$$Z_1 = \sqrt{5^2 + 6.28^2} = 8 \Omega$$

$$I_1 = 100/8 = 12.5 \text{ A}$$

$$\cos \phi_1 = R_1/Z_1 = 5/8$$

$$\sin \phi_1 = 6.28/8$$

**Branch No. 2**

$$X_2 = 314 \times 0.08 = 25.12 \Omega,$$

$$Z_2 = \sqrt{1^2 + 25.12^2} = 25.14 \Omega, I_2 = 100/25.14 = 4 \text{ A}$$

$$\cos \phi_2 = 1/25.14 \text{ and } \sin \phi_2 = 25.12/25.14$$

$$X\text{-components of } I_1 \text{ and } I_2 = I_1 \cos \phi_1 + I_2 \cos \phi_2 = (12.5 \times 5/8) + (4 \times 1/25.14) = 7.97 \text{ A}$$

$$Y\text{-components of } I_1 \text{ and } I_2 = I_1 \sin \phi_1 + I_2 \sin \phi_2 = (12.5 \times 6.28/8) + (4 \times 25.12/25.14) = 13.8 \text{ A}$$

$$I = \sqrt{7.97^2 + 13.8^2} = 15.94 \text{ A}$$

$$\cos \phi = 7.97/15.94 = 0.5 \text{ (lag)}$$

$$\phi = \cos^{-1}(0.5) = 60^\circ$$

Power absorbed

$$= 100 \times 15.94 \times 0.5 = 797 \text{ W}$$

The equivalent series circuit is shown in Fig. 14.17 (a).

$$V = 100 \text{ V}; I = 15.94 \text{ A}; \phi = 60^\circ$$

$$Z = 100/15.94 = 6.27 \Omega;$$

$$R = Z \cos \phi = 6.27 \times \cos 60^\circ = 3.14 \Omega$$

$$X = Z \sin \phi = 6.27 \times \sin 60^\circ = 5.43 \Omega$$

**Admittance Method For Finding Equivalent Circuit**

$$Y_1 = \frac{1}{5 + j6.28} = \frac{5 - j6.28}{5^2 + 6.28^2} = 0.078 - j0.098 \text{ S},$$

$$Y_2 = \frac{1}{1 + j25.12} = \frac{1 - j25.12}{1^2 + 25.12^2} = 0.00158 - j0.0397 \text{ S},$$

$$Y = Y_1 + Y_2 = 0.0796 - j0.138 = 0.159 \angle -60^\circ$$

Here

$$G = 0.0796 \text{ S}, B = -0.138 \text{ S}, Y = 0.159 \text{ S}$$

$$\therefore R_{eq} = G/Y^2 = 0.0796/0.159^2 = 3.14 \Omega, X_{eq} = B/Y^2 = 0.138/0.159^2 = 5.56 \Omega$$

**Example. 14.13.** A voltage of  $200 \angle 53^\circ 8'$  is applied across two impedances in parallel. The values of impedances are  $(12 + j16)$  and  $(10 - j20)$ . Determine the kVA, kVAR and kW in each branch and the power factor of the whole circuit. (Elect. Technology, Indore Univ.)

**Solution.** The circuit is shown in Fig. 14.18.

$$Y_A = 1/(12 + j16) = (12 - j16)/[(12 + j16)(12 - j16)] \\ = (12 - j16)/400 = 0.03 - j0.04 \text{ mho}$$

$$Y_B = 1/(10 - j20) = 10 + j20/[(10 - j20)(10 + j20)]$$

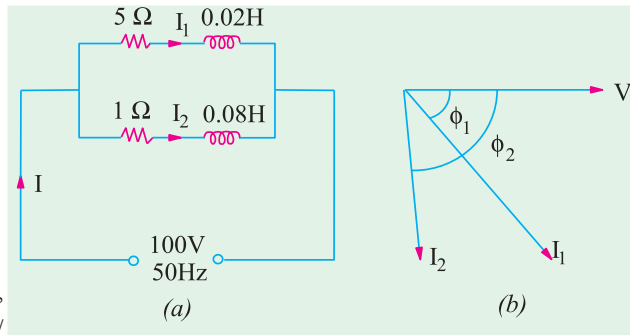

Fig. 14.16.

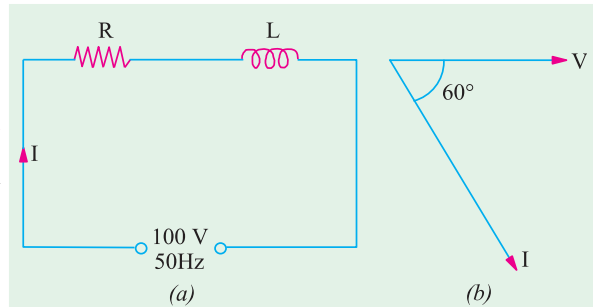

Fig. 14.17

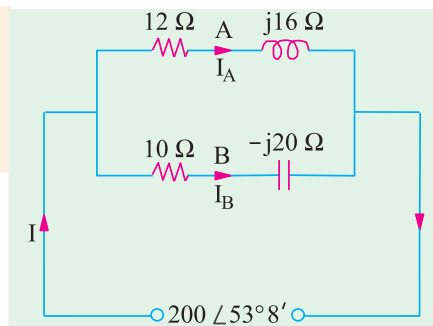

Fig. 14.18

$$= \frac{10 - j20}{500} \quad 0.02 \quad -j0.04 \text{ mho}$$

$$\begin{aligned} \text{Now } V &= 200 \angle 53^\circ 8' = 200 (\cos 53^\circ 8' + j \sin 53^\circ 8') \\ &= 2000 (0.6 + j0.8) = 120 + j160 \text{ volt} \end{aligned}$$

$$\begin{aligned} \mathbf{I}_A &= \mathbf{VY}_A = (120 + j160) (0.03 - j0.04) \\ &= (10 + j0) \text{ ampere (along the reference axis)} \end{aligned}$$

$$\begin{aligned} \therefore \mathbf{I}_B &= \mathbf{VY}_B = (120 + j160) (0.02 + j0.04) \\ &= -4.0 + j8 \text{ ampere (leading)} \end{aligned}$$

**Example 14.14.** Two circuits, the impedances of which are given by  $Z_1 = 15 + j12$  ohms and  $Z_2 = 8 - j5$  ohms are connected in parallel. If the potential difference across one of the impedance is  $250 + j0$  V, calculate.

- (i) total current and branch currents  
(ii) total power and power consumed in each branch  
and (iii) overall power-factor and power-factor of each branch.

(Nagpur University, November 1998)

**Solution.** (i)  $I_1 = (250 + j0)/(15 + j12) = 250 \angle 0^\circ / 19.21 \angle 38.6^\circ$   
 $= 13 \angle -38.6^\circ \text{ amp} = 13 (0.78 - j0.6247)$   
 $= 10.14 - j8.12 \text{ amp}$   
 $I_2 = (250 + j0)/(8 - j5) = 250 \angle 0^\circ / 9.434 \angle -32^\circ$   
 $= 26.5 \angle +32^\circ = 26.5 (0.848 + j0.530)$   
 $= 22.47 + j14.05 \text{ amp}$   
 $I = I_1 + I_2 = 32.61 + j5.93 = 33.15 \angle +10.36^\circ$

- (ii) Power in branch 1 =  $13^2 \times 15 = 2535$  watts  
Power in branch 2 =  $26.5^2 \times 8 = 5618$  watts  
Total power consumed =  $2535 + 5618 = 8153$  watts  
(iii) Power factor of branch 1 =  $\cos 38.60^\circ = 0.78$  lag  
Power factor of branch 2 =  $\cos 32^\circ = 0.848$  lead.  
Overall power factor =  $\cos 10.36^\circ = 0.984$  lead.

**Additional hint :** Drawn phasor-diagram for these currents, in fig. 14.19, for the expressions written above,

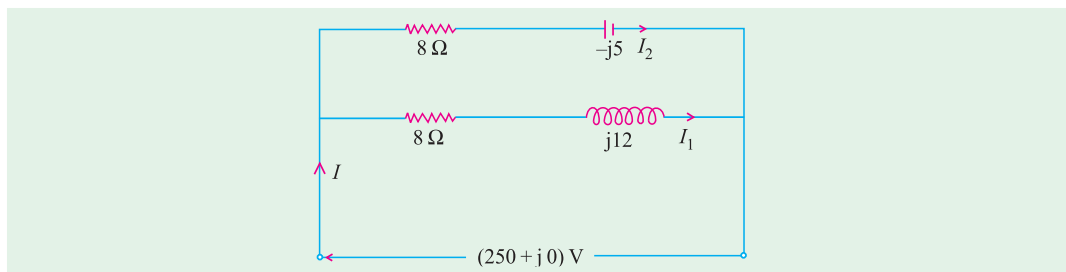

Fig. 14.19

**Example 14.15.** An inductive circuit, in parallel with a resistive circuit of 20 ohms is connected across a 50 Hz supply. The inductive current is 4.3 A and the resistive current is 2.7 A. The total current is 5.8 A Find : (a) Power factor of the combined circuit. Also draw the phasor diagram.

(Nagpur University, November 1997)

**Solution.**  $I_2$  (= 2.7 A) is in phase with V which is 54 V in magnitude. The triangle for currents is drawn in the phasor diagram in fig. 14.20 (b)

Solving the triangle,  $\phi_1 = 180^\circ - \cos^{-1} [(2.7^2 = 4.3^2 - 5.8^2)/(2 \times 4.3 \times 2.7)] = 70.2^\circ$

Further,  $5.8 \sin \phi = 4.3 \sin \phi_1$ , giving  $\phi = 44.2^\circ$ .

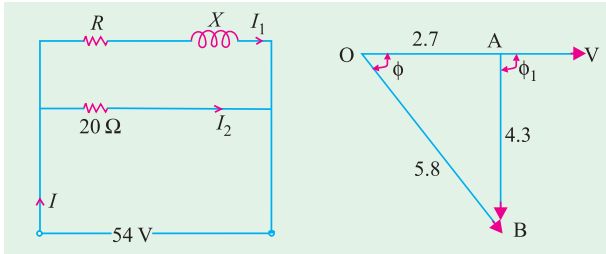

Fig. 14.20 (a)

Fig. 14.20 (b)

OA =  $I_2 = 2.7$  in phase with V  
 AB =  $I_1 = 4.3$  lagging behind V by  $\phi_1$   
 OB =  $I = 5.8$  lagging behind V by  $\phi$

$$|Z_1| = 54/4.3 = 12.56 \text{ ohms}$$

$$R = Z_1 \cos \phi_1 = 4.25 \text{ ohms}$$

$$X = Z_1 \sin \phi_1 = 11.82 \text{ ohms, since } \phi_1 \text{ is the lagging angle}$$

(a) Power absorbed by the Inductive branch

$$= 4.3^2 \times 4.25 = 78.6 \text{ watts}$$

(b)  $L = 11.82/314 = 37.64 \text{ mH}$

(c) P.f. of the combined circuit =  $\cos \phi = 0.717$  lag

**Check :** Power consumed by 20 ohms resistor =  $2.7^2 \times 20 = 145.8 \text{ W}$

Total Power consumed in two branches =  $78.6 + 145.8 = 224.4 \text{ W}$

This figure must be obtained by input power =  $VI \cos \phi$

=  $54 \times 5.8 \times \cos 44.2^\circ = 224.5 \text{ W}$ . Hence checked.

**Example 14.16.** In a particular A.C. circuit, three impedances are connected in parallel, currents as shown in fig. 14.21 are flowing through its parallel branches.

(i) Write the equations for the currents in terms of sinusoidal variations and draw the wave-forms.

Find the total current supplied by the source.

[Nagpur University, April 1998]

**Solution.** In Fig. 14.21, V is taken as reference, and is very convenient for phasor diagrams for parallel circuits.

(i)  $I_1$  lags behind by  $30^\circ$ . Branch no. 1 must, therefore, have an R-L series combination. With 10-volt source, a current of 3 A in branch 1 means that its impedance  $Z_1$  is given by

$$Z_1 = 10/3 = 3.333 \text{ ohms}$$

The phase-angle for  $I_1$  is  $30^\circ$  lagging

$$R_1 = 3.333 \cos 30^\circ = 2.887 \text{ ohms}$$

$$X_{L1} = 3.333 \sin 30^\circ = 1.6665 \text{ ohms}$$

(ii)  $I_2$  is 2 amp and it leads the voltage by  $45^\circ$ . Branch 2 must, therefore, have R-C series combination.

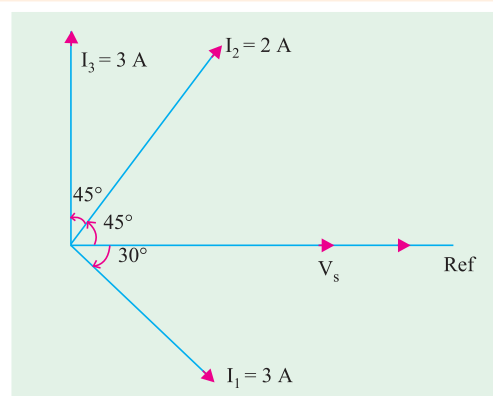

Fig. 14.21

$$Z_2 = 10/2 = 5 \text{ ohms}$$

$$R_2 = 5 \cos 45^\circ = 3.5355 \text{ ohms}$$

$$X_{c2} = 5 \sin 45^\circ = 3.5355 \text{ ohms}$$

(iii) Third branch draws a current of 3 amp which leads the voltage by  $90^\circ$ . Hence, it can only have a capacitive reactance.

$$|Z_3| = X_{c3} = 10/3 = 3.333 \text{ ohms}$$

Total current supplied by the source =  $I$  amp

$$\begin{aligned} I &= I_1 + I_2 + I_3 \\ &= 3 [\cos 30^\circ - j \sin 30^\circ] + 2 [\cos 45^\circ + j \sin 45^\circ] + 3 [0 + j 1] \\ &= 4.0123 + j 2.9142 \end{aligned}$$

$$|I| = 4.96 \text{ amp, leading } V_s \text{ by } 36^\circ.$$

Expressions for currents : Frequency is assumed to be 50 Hz

$$v_s = 10\sqrt{2} \sin (314 t)$$

$$i_1 = 3\sqrt{2} \sin (314 t - 30^\circ)$$

$$i_2 = 2\sqrt{2} \sin (314 t + 45^\circ)$$

$$i_3 = 3\sqrt{2} \sin (314 t + 90^\circ)$$

$$\text{Total current, } i(t) = 4.96\sqrt{2} \sin (314 t + 36^\circ)$$

$$\begin{aligned} \text{Total power consumed} &= \text{Voltage} \times \text{active (or in phase-) component of current} \\ &= 10 \times 4.012 = 40.12 \text{ watts} \end{aligned}$$

**Example 14.17.** A resistor of 12 ohms and an inductance of 0.025 H are connected in series across a 50 Hz supply. What values of resistance and inductance when connected in parallel will have the same resultant impedance and p.f. Find the current in each case when the supply voltage is 230 V. (Nagpur University, Nov. 1996)

**Solution.** At 50 Hz, the series R-L circuit has an impedance of  $Z_s$  given by

$$Z_s = 12 + j(314 \times 0.025) = 12 + j 7.85 = 14.34 + \angle 33.2^\circ$$

$$\begin{aligned} I_s &= (230 + j0) / (12 + j 7.85) = 16.04 - \angle 33.2^\circ \\ &= 13.42 - j 8.8 \text{ amp} \end{aligned}$$

Out of these two components of  $I_s$ , the in-phase component is 13.42 amp and quadrature component (lagging) is 8.8 amp. Now let the R-L parallel combination be considered. In Fig. 14.22 (b), R carries the in-phase component, and L carries the quadrature-component (lagging). For the two systems to be equivalent,

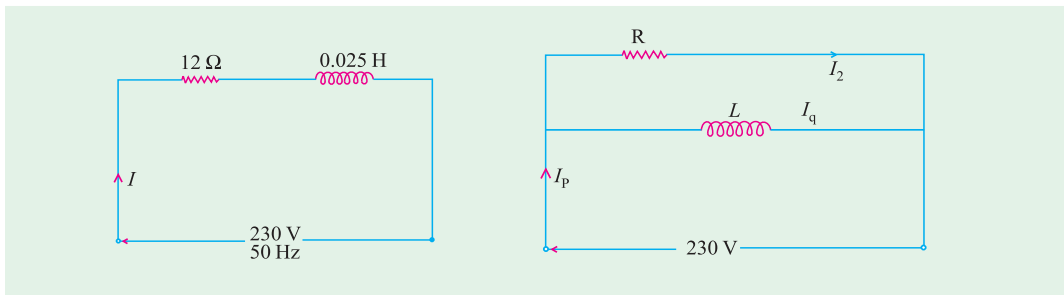

Fig. 14.22 (a)

Fig. 14.22 (b)

$$\begin{aligned} \text{It means} \quad I_s &= I_p \\ I_s &= 13.42 \text{ amp} \\ I_q &= 8.8 \text{ amp} \\ \text{Thus,} \quad R &= 230 / 13.42 = 17.14 \text{ ohms} \end{aligned}$$

$$X_L = 230 / 8.8 = 26.14 \text{ ohms}$$

$$L = 26.14/314 = 83.2 \text{ mH}$$

**Example 14.18.** An inductive coil of resistance 15 ohms and inductive reactance 42 ohms is connected in parallel with a capacitor of capacitive reactance 47.6 ohms. The combination is energized from a 200 V, 33.5 Hz a.c. supply. Find the total current drawn by the circuit and its power factor. Draw to the scale the phasor diagram of the circuit. (Bombay University, 2000)

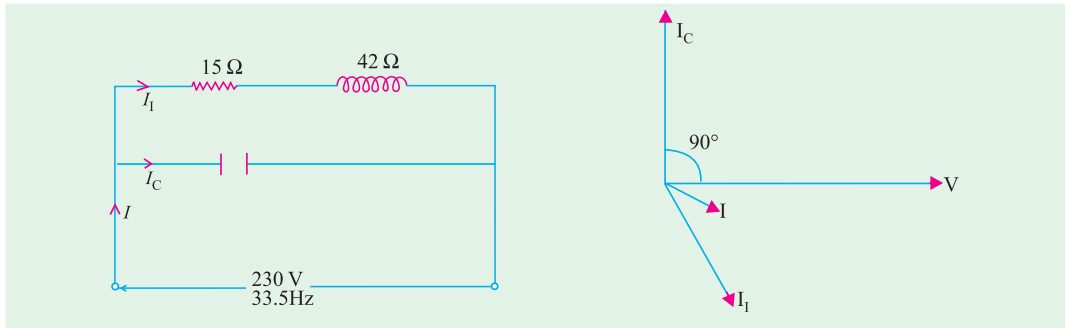

Fig. 14.23 (a)

Fig. 14.23 (b)

**Solution.**

$$Z_1 = 15 + j42, Z_1 = 44.6 \text{ ohms}, \cos \phi_1 = 15/44.6 = 0.3363$$

$$\phi_1 = 70.40 \text{ Lagging}, I_1 = 200/44.6 = 4.484 \text{ amp}$$

$$I_c = 200/47.6 = 4.2 \text{ amp}$$

$$I = 4.484 (0.3355 - j0.942) + j4.2 = 1.50 - j0.025 = 1.5002 \angle -1^\circ$$

For the circuit in Fig. 14.23 (a), the phasor diagram is drawn in Fig. 14.23 (b).

#### Power Calculation

Power etc. can be calculated by the method of conjugates as explained in Ex. 14.3

#### Branch A

The current conjugate of  $(10 + j0)$  is  $(10 - j0)$

$$\therefore \text{VIA} = (120 + j160)(10 - j0) = 1200 + j1600 \quad \therefore \text{kW} = 1200/1000 = 1.2$$

$$\therefore \text{kVAR} = 1600/1000 = 1.6. \text{ The fact that it is positive merely shows the reactive}$$

$$\text{volt-amperes are due to a lagging current}^* \text{ kVA} = \sqrt{(1.2^2 + 1.6^2)} = 2$$

#### Branch B

The current conjugate of  $(-4.0 + j8)$  is  $(-4.0 - j8)$

$$\therefore \text{VI}_B = (120 + j160)(-4 - j8) = 800 - j1600$$

$$\therefore \text{kW} = 800/1000 = 0.8 \quad \therefore \text{kVAR} = -1600/1000 = -1.6$$

The negative sign merely indicates that reactive volt-amperes are due to the leading current

$$\therefore \text{kVA} = \sqrt{[0.8^2 + (-1.6)^2]} = 1.788$$

$$\mathbf{Y} = \mathbf{Y}_A + \mathbf{Y}_B = (0.03 - j0.04) + (0.02 + j0.04) = 0.05 + j0$$

$$\mathbf{I} = \mathbf{VY} = (120 + j160)(0.05 + j0) = 6 + j8 = 10 \angle 53^\circ 8'$$

$$\text{or } \mathbf{I} = \mathbf{I}_A + \mathbf{I}_B = (10 + j0) + (-4 + j8) = 6 + j8 \quad (\text{same as above})$$

$$\text{Circuit p.f.} = \cos 0^\circ = 1 \quad (\because \text{current is in phase with voltage})$$

\* If voltage conjugate is used, then capacitive VARs are positive and inductive VARs negative.

**Example 14.19.** An impedance  $Z_1 = (8 - j5) \Omega$  is in parallel with an impedance  $Z_2 = (3 + j7) \Omega$ . If 100 V are impressed on the parallel combination, find the branch currents  $I_1$ ,  $I_2$  and the resultant current. Draw the corresponding phasor diagram showing each current and the voltage drop across each parameter. Calculate also the equivalent resistance, reactance and impedance of the whole circuit. (Elect. Technology-I, Gwalior Univ. 1998)

**Solution. Admittance Method**

$$Y_1 = 1/(8 - j5) = (0.0899 + j0.0562) S$$

$$Y_2 = 1/(3 + j7) = (0.0517 - j0.121) S, Y = Y_1 + Y_2 = (0.1416 - j0.065) S$$

$$\text{Let } V = (100 + j0); I_1 = VY_1 = 100(0.0899 + j0.0562) = 8.99 + j5.62$$

$$I_2 = VY_2 = 100(0.0517 - j0.121) = 5.17 - j12.1; I = VY = 100(0.1416 - j0.065) = 14.16 - j6.5$$

$$\text{Now, } G = 0.1416 S, B = -0.065 S \text{ (inductive)}$$

$$Y = \sqrt{G^2 + B^2} = \sqrt{0.1416^2 + 0.065^2} = 0.1558 S$$

$$\text{Equivalent series resistance, } R_{eq} = G/Y^2 = 0.1416/0.1558^2 = 5.38 \Omega$$

$$\text{Equivalent series inductive reactance } X_{eq} = B/Y^2 = 0.065/0.1558^2 = 2.68 \Omega$$

$$\text{Equivalent series impedance } Z = 1/Y = 1/0.1558 = 6.42 \Omega$$

**Impedance Method**

$$I_1 = V/Z_1 = (100 + j0) / (8 - j5) = 8.99 + j5.62$$

$$I_2 = V/Z_2 = 100/(3 + j7) = 5.17 - j12.1$$

$$Z = \frac{Z_1 Z_2}{Z_1 + Z_2} = \frac{(8 - j5)(3 + j7)}{(11 - j2)} = \frac{59 + j41}{(11 - j2)} = 5.848 + j2.664 = 6.426 \angle 24.5^\circ,$$

$$I = 100/6.426 \angle 24.5^\circ = 15.56 \angle -24.5^\circ = 14.16 - j 6.54$$

As seen from the expression for  $Z$ , equivalent series resistance is **5.848**  $\Omega$  and inductive reactance is **2.664 ohm**.

**Example 14.20.** The impedances  $Z_1 = 6 + j 8$ ,  $Z_2 = 8 - j 6$  and  $Z_3 = 10 + j 0$  ohms measured at 50 Hz, form three branches of a parallel circuit. This circuit is fed from a 100 volt, 50-Hz supply. A purely reactive (inductive or capacitive) circuit is added as the fourth parallel branch to the above three-branched parallel circuit so as to draw minimum current from the source. Determine the value of  $L$  or  $C$  to be used in the fourth branch and also find the minimum current. (Electrical Circuits, South Gujarat Univ.)

**Solution.** Total admittance of the 3-branched parallel circuit is

$$Y = \frac{1}{6 + j8} + \frac{1}{8 - j6} + \frac{1}{10 + j0} = 0.06 - j0.08 + 0.08 + j0.06 + 0.1 = 0.24 - j0.02$$

Current taken would be minimum when net susceptance is zero. Since combined susceptance is inductive, it means that we must add capacitive susceptance to neutralize it. Hence, we must connect a pure capacitor in parallel with the above circuit such that its susceptance equals  $+j0.02 S$

$$\therefore I/X_C = 0.02 \text{ or } 2\pi/C = 0.02; C = 0.2/314 = 63.7 \mu F$$

$$\text{Admittance of four parallel branches} = (0.24 - j0.02) + j0.02 = 0.24 S$$

$$\therefore \text{Minimum current drawn by the circuit} = 100 \times 0.24 = 24 A$$

**Example 14.21.** The total effective current drawn by parallel circuit of Fig. 14.24 (a) is 20 A. Calculate (i) VA (ii) VAR and (iii) watts drawn by the circuit.

**Solution.** The combined impedance of the circuit is

$$Z = \frac{Z_1 Z_2}{Z_1 + Z_2} = \frac{10(6 - j8)}{(16 - j8)} = (5 - j2.5) \text{ ohm}$$

(iii) Power =  $I^2 R = 20^2 \times 5 = 2000 \text{ W}$  (ii)  $Q = I^2 X = 20^2 \times 2.5 = 1000 \text{ VAR (leading)}$  (i)  $S = P + jQ = 2000 + j1000 = 2236 \angle 27^\circ$ ;  $S = 2236 \text{ VA}$

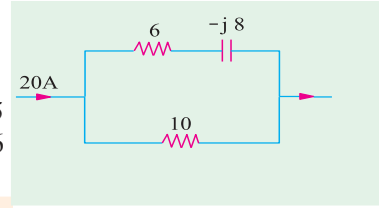

Fig. 14.24. (a)

**Example 14.22.** Calculate (i) total current and (ii) equivalent impedance for the four-branched circuit of Fig. 14.24 (b).

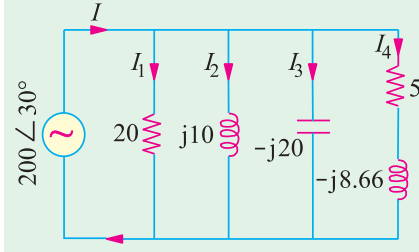

Fig. 14.24 (b)

**Solution.**  $Y_1 = 1/20 = 0.05 \text{ S}$ ,  $Y_2 = 1/j10 = -j0.1 \text{ S}$ ;  
 $Y_3 = 1/-j20 = j0.05 \text{ S}$ ;  $Y_4 = 1/5 - j8.66 = 1/10 \angle 60^\circ$   
 $= 0.1 \angle 60^\circ = (0.05 - j0.0866) \text{ S}$   
 $Y = Y_1 + Y_2 + Y_3 + Y_4 = (0.1 - j0.1366) \text{ S}$   
 $= 0.169 \angle 53.8^\circ \text{ S}$   
 (i)  $I = VY = 200 \angle 30^\circ \times 0.169 \angle 53.8^\circ = 33.8 \angle 23.8^\circ \text{ A}$   
 (ii)  $Z = 1/Y = 1/0.169 \angle 53.8^\circ = 5.9 \angle 53.8^\circ \Omega$

**Example 14.23.** The power consumed by both branches of the circuit shown in Fig. 14.23 is 2200 W. Calculate power of each branch and the reading of the ammeter.

**Solution.**  $I_1 = V/Z_1$   
 $= V/(6 + j8) = V/10 \angle 53.1^\circ$ ,  $I_2 = V/Z_2 = V/20$   
 $\therefore I_1/I_2 = 20/10 = 2$ ,  $P_1 = I_1^2 R_1$  and  $P_2 = I_2^2 R_2$   
 $\therefore \frac{P_1}{P_2} = \frac{I_1^2 R_1}{I_2^2 R_2} = 2^2 \times \left(\frac{6}{20}\right) = \frac{6}{5}$

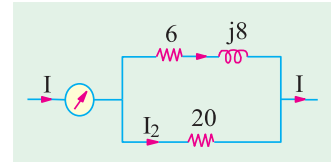

Fig. 14.25

Now,  $P = P_1 + P_2$  or  $\frac{P}{P_2} = \frac{P_1}{P_2} + 1 = \frac{6}{5} + 1 = \frac{11}{5}$

or  $P_2 = 2200 \times \frac{5}{11} = 1000 \text{ W}$   $\therefore P_1 = 2200 - 1000 = 1200 \text{ W}$

Since  $P_1 = I_1^2 R_1$  or  $1200 = I_1^2 \times 6$ ;  $I_1 = 14.14 \text{ A}$

If  $V = V \angle 0^\circ$ , then  $I_1 = 14.14 \angle 53.1^\circ = 8.48 - j11.31$

Similarly,  $P_2 = I_2^2 R_2$  or  $1000 = I_2^2 \times 20$ ;  $I_2 = 7.07 \text{ A}$  or  $I_2 = 7.07 \angle 0^\circ$

Total current  $I = I_1 + I_2 = (8.48 - j11.31) + 7.07 = 15.55 - j11.31 = 19.3 \angle 36^\circ$

Hence, ammeter reads **19.3 A**

**Example 14.24.** Consider an electric circuit shown in Figure 14.25 (a)

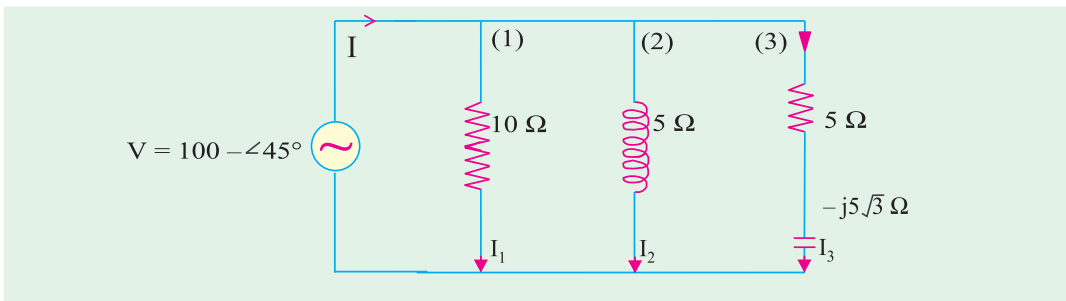

Fig. 14.25. (a)

**Determine :** (i) the current and power consumed in each branch.

(ii) the supply current and power factor. (U.P. Technical University, 2001)

**Solution.** Indicating branch numbers 1, 2, 3 as marked on the figure, and representing the source voltage by  $100 \angle 45^\circ$ ,

$$Z_1 = 10 + j0 = 10 \angle 0^\circ, I_1 = 100 \angle 45^\circ / 10 \angle 0^\circ = 10 \angle 45^\circ \text{ amp}$$

$$Z_2 = 5 + j5\sqrt{3} = 10 \angle 60^\circ, I_2 = 100 \angle 45^\circ / 10 \angle 60^\circ = 10 \angle -15^\circ \text{ amp}$$

$$Z_3 = 5 - j5\sqrt{3} = 10 \angle -60^\circ, I_3 = 100 \angle 45^\circ / 10 \angle -60^\circ = 10 \angle 105^\circ \text{ amp}$$

Phasor addition of these three currents gives the supply current,  $I$  which comes out to be  $I = 20 \angle 45^\circ$  amp.

This is in phase with the supply voltage.

(i) Power consumed by the branches :

Branch 1 :  $10^2 \times 10 = 1000$  watts

Branch 2 :  $10^2 \times 5 = 500$  watts

Branch 3 :  $10^2 \times 5 = 500$  watts

Total power consumed = 2000 watts

(ii) Power factor = 1.0 since  $V$  and  $I$  are in phase

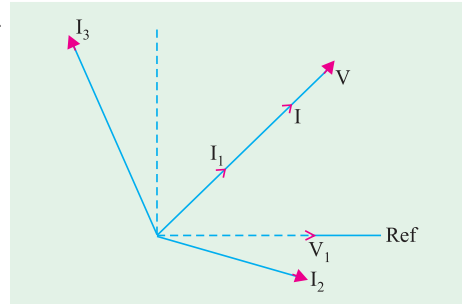

Fig. 14.25 (b)

### 14.6. Series-parallel Circuits

(i) *By Admittance Method*

In such circuits, the parallel circuit is first reduced to an equivalent series circuit and then, as usual, combined with the rest of the circuit. For a parallel circuit,

$$\text{Equivalent series resistance } R_{eq} = Z \cos \phi = \frac{1}{Y} \cdot \frac{G}{Y} = \frac{G}{Y^2}$$

- Sec Ex. 14.14

$$\text{Equivalent series reactance } X_{eq} = Z \sin \phi = \frac{1}{Y} \cdot \frac{B}{Y} = \frac{B}{Y^2}$$

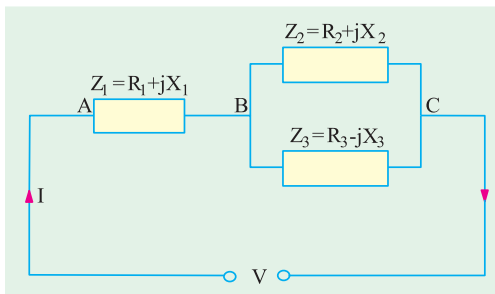

Fig. 14.26

(ii) *By Symbolic Method*

Consider the circuit of Fig. 14.26. First, equivalent impedance of parallel branches is calculated and it is then added to the series impedance to get the total circuit impedance. The circuit current can be easily found.

$$Y_2 = \frac{1}{R_2 - jX_2}; Y_3 = \frac{1}{R_3 + jX_3}$$

$$\therefore Y_{23} = \frac{1}{R_2 - jX_2} + \frac{1}{R_3 + jX_3}$$

$$\therefore Z_{23} = \frac{1}{Y_{23}}; Z_1 = R_1 + jX_1; Z = Z_{23} + Z_1$$

$$\therefore I = \frac{V}{Z} \quad \text{(Sec Ex. 14.21)}$$

### 14.7. Series Equivalent of a Parallel Circuit

Consider the parallel circuit of Fig. 14.27 (a). As discussed in Art. 14.5

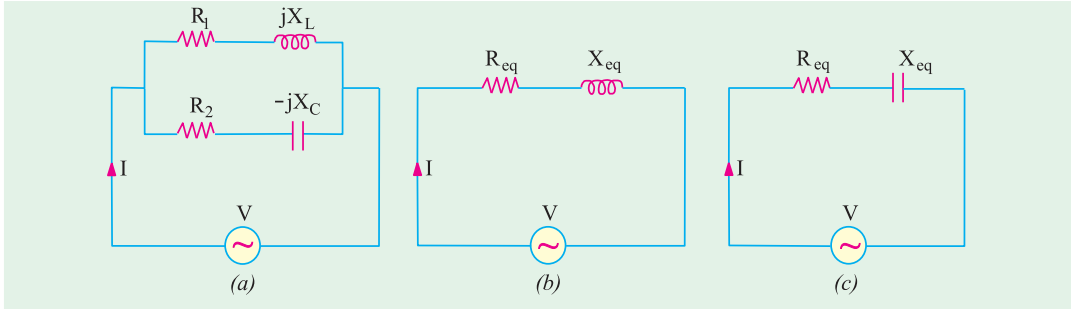

Fig. 14.27

$$Y_1 = \frac{R_1}{R_1^2 + X_L^2} + j \frac{X_L}{R_1^2 + X_L^2} \quad g_1 \quad jb_1; \quad Y_2 = \frac{R_2}{R_2^2 + X_c^2} + j \frac{X_c}{R_2^2 + X_c^2} \quad g_2 \quad jb_2$$

$$Y = Y_1 + Y_2 = g_1 - jb_1 + g_2 + jb_2 = (g_1 + g_2) + j(b_2 - b_1) = G + jB = \sqrt{G^2 + B^2} \angle \tan^{-1}(B/G)$$

As seen from Fig. 14.28.

$$R_{eq} = Z \cos \phi = \frac{1}{Y} \cdot \frac{G}{Y} = \frac{G}{Y^2}$$

$$X_{eq} = Z \sin \phi = \frac{1}{Y} \cdot \frac{B}{Y} = \frac{B}{Y^2}$$

Hence, equivalent series circuit is as shown in Fig. 14.27 (b) or (c) depending on whether net susceptance  $B$  is negative (inductive) or positive (capacitive). If  $B$  is negative, then it is an  $R$ - $L$  circuit of Fig. 14.27 (b) and if  $B$  is positive, then it is an  $R$ - $C$  circuit of Fig. 14.27 (c).

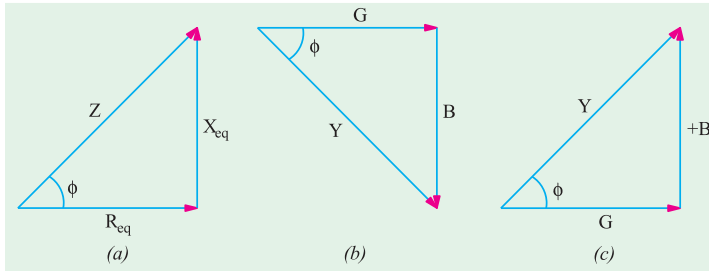

Fig. 14.28

### 14.8. Parallel Equivalent of a Series Circuit

The two circuits will be equivalent if  $Y$  of Fig. 14.29 (a) is equal to the  $Y$  of the circuit of Fig. 14.29 (b).

#### Series Circuit

$$Y_s = \frac{1}{R_s + jX_s}$$

$$= \frac{R_s - jX_s}{(R_s + jX_s)(R_s - jX_s)}$$

$$= \frac{R_s - jX_s}{R_s^2 + X_s^2} = \frac{R_s}{R_s^2 + X_s^2} - j \frac{X_s}{R_s^2 + X_s^2}$$

#### Parallel Circuit

$$Y_p = \frac{1}{R_p + j0} + \frac{1}{0 + jX_p} = \frac{1}{R_p} + \frac{1}{jX_p} = \frac{1}{R_p} - \frac{j}{X_p}$$

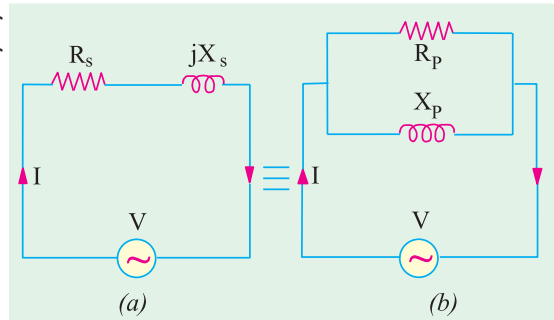

Fig. 14.29

$$\therefore \frac{R_s}{R_s^2 + X_s^2} - j \frac{X_s}{R_s^2 + X_s^2} = \frac{1}{R_p} - \frac{j}{X_p} \quad \therefore \frac{1}{R_p} = \frac{R_s}{R_s^2 + X_s^2} \quad \text{or } R_p = R_s + \frac{X_s^2}{R_s} = R_s \left( 1 + \frac{X_s^2}{R_s^2} \right)$$

$$\text{Similarly } X_p = X_s + \frac{R_s^2}{X_s} = X_s \left( 1 + \frac{R_s^2}{X_s^2} \right)$$

**Example 14.25.** The admittance of a circuit is  $(0.03 - j0.04)$  Siemens. Find the values of the resistance and inductive reactance of the circuit if they are joined (a) in series and (b) in parallel.

**Solution. (a)**  $Y = 0.03 - j0.04$

$$\therefore Z = \frac{1}{Y} = \frac{1}{0.03 - j0.04} = \frac{0.03 + j0.04}{0.03^2 + 0.04^2} = \frac{0.03 + j0.04}{0.0025} = 12 + j16$$

Hence, if the circuit consists of a resistance and inductive reactance in series, then resistance is  $12 \Omega$  and inductive reactance is  $16 \Omega$  as shown in Fig. 14.30.

(b) Conductance =  $0.03$  mho  $\therefore$  Resistance =  $1/0.03 = 33.3 \Omega$

Susceptance (inductive) =  $0.04$  S  $\therefore$  Inductive reactance =  $1/0.04 = 25 \Omega$

Hence, if the circuit consists of a resistance connected in parallel with an inductive reactance, then resistance is  $33.3 \Omega$  and inductive reactance is  $25 \Omega$  as shown in Fig. 14.31.

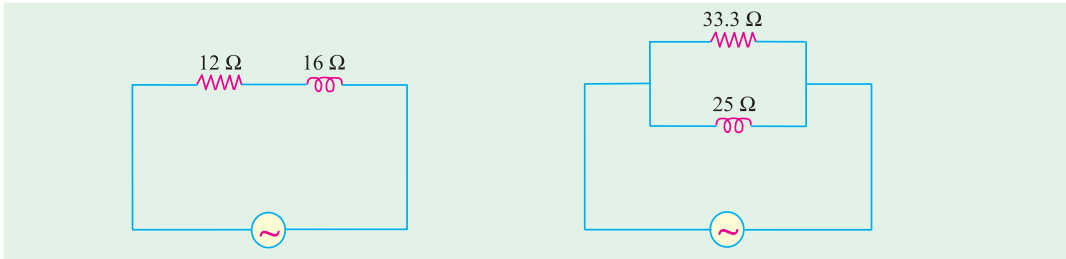

Fig. 14.30

Fig. 14.31

**Example 14.26.** A circuit connected to a 115-V, 50-Hz supply takes 0.8 A at a power factor of 0.3 lagging. Calculate the resistance and inductance of the circuit assuming (a) the circuit consists of a resistance and inductance in series and (b) the circuit consists of a resistance and inductance in parallel. (Elect. Engg.-I, Sardar Patel Univ.)

**Solution. Series Combination**

$$Z = 115/0.8 = 143.7 \Omega; \cos \phi = R/Z = 0.3 \quad \therefore R = 0.3 \times 143.7 = 43.1 \Omega$$

$$\text{Now } X_L = \sqrt{Z^2 - R^2} = \sqrt{143.7^2 - 43.1^2} = 137.1 \Omega$$

$$\therefore L = 137.1/2\pi \times 50 = 0.436 \text{ H}$$

**Parallel Combination**

Active component of current (drawn by resistance)

$$= 0.8 \cos \phi = 0.8 \times 0.3 = 0.24 \text{ A}; R = 115/0.24 = 479 \Omega$$

Quadrature component of current (drawn by inductance) =  $0.8 \sin \phi = 0.8 \sqrt{1 - 0.3^2} = 0.763 \text{ A}$

$$\therefore X_L = 115/0.763 \Omega \quad \therefore L = 115/0.763 \times 2\pi \times 50 = 0.48 \text{ H}$$

**Example 14.27.** The active and lagging reactive components of the current taken by an a.c. circuit from a 250-V supply are 50 A and 25 A respectively. Calculate the conductance, susceptance, admittance and power factor of the circuit. What resistance and reactance would an inductive coil have if it took the same current from the same mains at the same factor?

(Elect. Technology, Sumbal Univ.)

**Solution.** The circuit is shown in Fig. 14.32.

$$\text{Resistance} = 250/50 = 5 \Omega; \text{Reactance} = 250/25 = 10 \Omega$$

$\therefore$  Conductance  $g = 1/5 = 0.2 \text{ S}$ , Susceptance  $b = -1/10 = -0.1 \text{ S}$

Admittance  $Y = \sqrt{g^2 + b^2} = \sqrt{0.2^2 + (-0.1)^2} = \sqrt{0.05} = 0.224 \text{ S}$

$Y = 0.2 - j 0.1 = 0.224 \angle -26^\circ 34'$ . Obviously, the total current lags the supply voltage by  $26^\circ 34'$ , p.f. =  $\cos 26^\circ 34' = 0.894$  (lag)

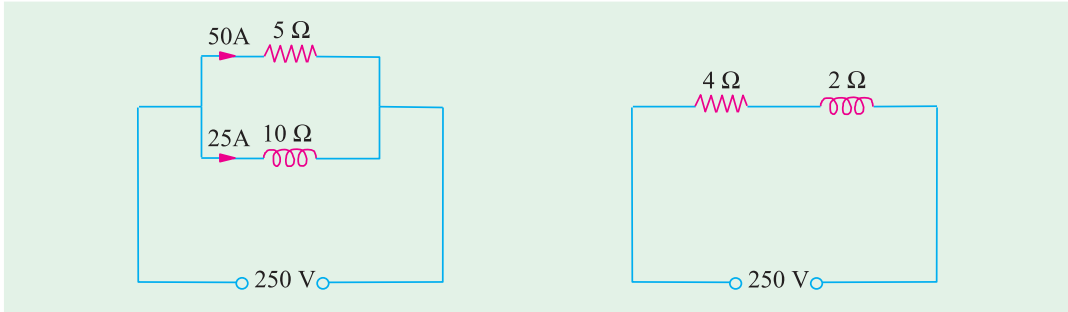

Fig. 14.32

Fig. 14.33

$$\text{Now } Z = \frac{1}{Y} = \frac{1}{0.2 - j0.1} = \frac{0.2 + j0.1}{0.05} = 4 + j2$$

Hence, resistance of the coil =  $4 \Omega$

Reactance of the coil =  $2 \Omega$  (Fig. 14.33)

**Example 14.28.** The series and parallel circuits shown in Fig. 14.34 have the same impedance and the same power factor. If  $R = 3 \Omega$  and  $X = 4 \Omega$ , find the values of  $R_1$  and  $X_1$ . Also, find the impedance and power factor. (Elect. Engg., Bombay Univ.)

**Solution. Series Circuit** [Fig. 14.34 (a)]

$$Y_S = \frac{1}{R + jX} = \frac{R - jX}{R^2 + X^2} = \frac{R}{R^2 + X^2} - j \frac{X}{R^2 + X^2}$$

**Parallel Circuit** [Fig. 14.34 (b)]

$$Y_P = \frac{1}{R_1 + j0} + \frac{1}{0 + jX_1} = \frac{1}{R_1} + \frac{1}{jX_1} = \frac{1}{R_1} - \frac{j}{X_1}$$

$$\therefore \frac{R}{R^2 + X^2} - j \frac{X}{R^2 + X^2} = \frac{1}{R_1} - \frac{j}{X_1}$$

$$\therefore R_1 = R + X^2/R \quad \text{and} \quad X_1 = X + R^2/X$$

$$\therefore R_1 = 3 + (16/3) = 8.33 \Omega \quad X_1 = 4 + (9/4) = 6.25 \Omega$$

Impedance =  $3 + j4 = 5 \angle 53.1^\circ$ ; Power factor =  $\cos 53.1^\circ = 0.6$  (lag)

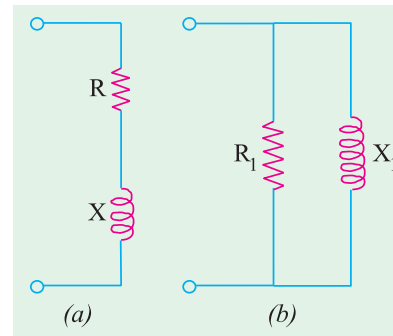

Fig. 14.34

**Example 14.29.** Find the value of the resistance  $R$  and inductance  $L$  which when connected in parallel will take the same current at the same power factor from 400-V, 50-Hz mains as a coil of resistance  $R_1 = 8 \Omega$  and an inductance  $L_1 = 0.2 \text{ H}$  from the same source of supply.

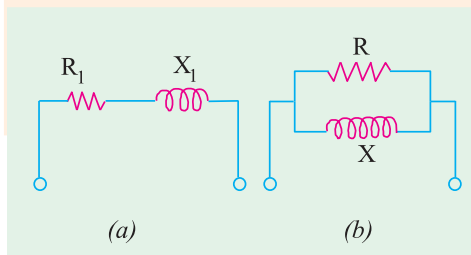

Fig. 14.35

Show that when the resistance  $R_1$  of the coil is small as compared to its inductance  $L_1$ , then  $R$  and  $L$  are respectively equal to  $\omega^2 L_1^2 / R_1$  and  $L_1$ .

(Elect. Technology, Utkal Univ.)

**Solution.** As seen from Art. 14.8 in Fig. 14.35.

$$R = R_1 + X_1^2 / R_1 \quad \dots (i)$$

$$X = X_1 + R_1^2 / X_1 \quad \dots (ii)$$

Now

$$R_1 = 8 \Omega, X_1 = 2\pi \times 50 \times 0.2 = 62.8 \Omega$$

$$\therefore R = 8 + (62.8^2/8) = 508 \Omega$$

$$X = 62.8 + (64/62.8) = 63.82 \Omega$$

From (i), it is seen that if  $R_1$  is negligible, then  $R = X_1^2/R_1 = \omega^2 L_1^2/R_1$

Similarly, from (ii) we find that the term  $R_1^2/X_1$  is negligible as compared to  $X_1$ ,

$$\therefore X = X_1 \text{ or } L = L_1$$

**Example 14.30.** Determine the current drawn by the following circuit [Fig. 14.36 (a)] when a voltage of 200 V is applied across the same. Draw the phasor diagram.

**Solution.** As seen from the figure

$$Z_2 = 10 - j12 = 15.6 \angle -50.2^\circ; Z_3 = 6 + j10 = 11.7 \angle 58^\circ$$

$$Z_1 = 4 + j6 = 7.2 \angle 56.3^\circ; Z_{BC} = \frac{(10 - j12)(6 + j10)}{16 - j2} = 10.9 + j3.1 = 11.3 \angle 15.9^\circ$$

$$Z = Z_1 + Z_{BC} = (4 + j6) + (10.9 + j3.1) = 14.9 + j9.1 = 17.5 \angle 31.4^\circ$$

$$\text{Assuming } V = 200 \angle 0^\circ; I = \frac{V}{Z} = \frac{200}{17.5 \angle 31.4} = 11.4$$

For drawing the phasor diagram, let us find the following quantities :

$$(i) V_{AB} = I Z_1 = 11.4 \angle -31.4^\circ \times 7.2 \angle 56.3^\circ = 82.2 \angle 24.9^\circ$$

$$V_{BC} = I Z_{BC} = 11.4 \angle -31.4^\circ \times 11.3 \angle 15.9^\circ = 128.8 \angle -15.5^\circ$$

$$I_2 = \frac{V_{BC}}{Z_2} = \frac{128.8}{15.6} \angle \frac{5.5}{50.2^\circ} = 8.25 \angle 34.7^\circ$$

$$I_3 = \frac{128.8}{11.7} \angle \frac{5.5}{58^\circ} = 15.1 \angle 74.5^\circ$$

Various currents and voltages are shown in their phase relationship in Fig. 14.36 (b).

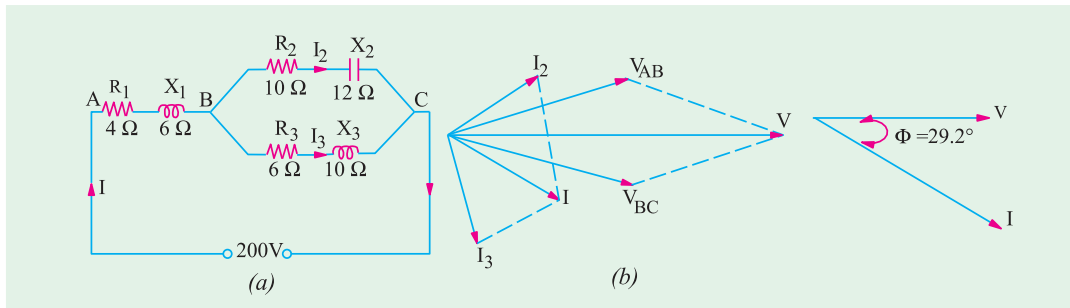

Fig. 14.36

Fig. 14.37 (a)

**Example 14.31.** For the circuit shown in Fig. 14.37 (a), find (i) total impedance (ii) total current (iii) total power absorbed and power-factor. Draw a vector diagram.

(Elect. Tech. Osmania Univ. Jan/Feb 1992)

**Solution.**  $Z_{BC} = (4 + j8) \parallel (5 - j8) = 9.33 + j0.89$

$$(i) Z_{AC} = 3 + j6 + 9.33 + j0.89 = 12.33 + j6.89 = 14.13 \angle 29.2^\circ$$

$$(ii) I = 100/14.13 \angle 29.2^\circ, \text{ as drawn in Fig. 14.37 (b)}$$

$$= 7.08 \angle -29.2^\circ$$

$$(iii) \phi = 29.2^\circ; \cos \phi = 0.873; P = VI \cos \phi$$

$$= 100 \times 7.08 \times 0.873 = 618 \text{ W}$$

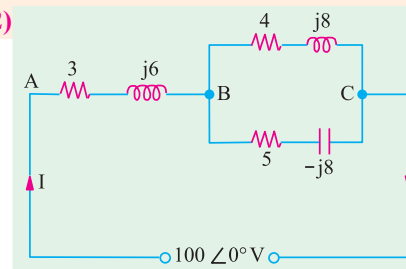

Fig. 14.37 (b)

**Example 14.32.** In a series-parallel circuit, the parallel branches A and B are in series with C. The impedances are :  $Z_A = (4 + j3)$  ;  $Z_B = (4 - j16/3)$ ;  $Z_C = (2 + j8)$  ohm.

If the current  $I_C = (25 + j0)$ , draw the complete phasor diagram determining the branch currents and voltages and the total voltage. Hence, calculate the complex power (the active and reactance powers) for each branch and the whole circuits. (Basic Electricity, Bombay Univ.)

**Solution.** The circuit is shown in Fig. 14.38 (a)

$$Z_A = (4 + j3) = 5 \angle 36^\circ 52' ; Z_B = (4 - j16/3) = 20/3 \angle -53^\circ 8' ; Z_C = (2 + j8) = 8.25 \angle 76^\circ$$

$$I_C = (25 + j0) = 25 \angle 0^\circ ; V_C = I_C Z_C = 206 \angle 76^\circ$$

$$Z_{AB} = \frac{(4 + j3)(4 - j16/3)}{(8 - j7/3)} = \frac{(32 - j28/3)}{(8 - j7/3)} = 4 + j0 = 4 \angle 0^\circ$$

$$V_{AB} = I_C Z_{AB} = 25 \angle 0^\circ \times 4 \angle 0^\circ = 100 \angle 0^\circ$$

$$Z = Z_C + Z_{AB} = (2 + j8) + (4 + j0) = (6 + j8) = 10 \angle 53^\circ 8' ; V = I_C Z = 25 \angle 0^\circ \times 10 \angle 53^\circ 8' = 250 \angle 53^\circ 8'$$

$$I_A = \frac{V_{AB}}{Z_A} = \frac{100}{5} = 20 \quad 52 ; I_B = \frac{V_{AB}}{Z_B} = \frac{100}{(20/3)} = 15 \quad 53 \quad 8$$

Various voltages and currents are shown in Fig. 14.38 (b). Powers would be calculated by using voltage conjugates.

$$\text{Power for whole circuit is } P = VI_C = 250 \angle 53^\circ 8' \times 25 \angle 0^\circ = 6,250 \angle 53^\circ 8'$$

$$= 6250 (\cos 53^\circ 8' - j \sin 53^\circ 8') = 3750 - j5000$$

$$P_C = 25 \times 206 \angle -76^\circ = 5150 (\cos 76^\circ - j \sin 76^\circ) = 1250 - j5000$$

$$P_A = 100 \times 20 \angle -36^\circ 52' = 2000 \angle -36^\circ 52' = 1600 - j1200$$

$$P_B = 100 \times 15 \angle 53^\circ 8' = (900 + j1200); \text{ Total} = 3,750 - j5000^\circ \text{ (as a check)}$$

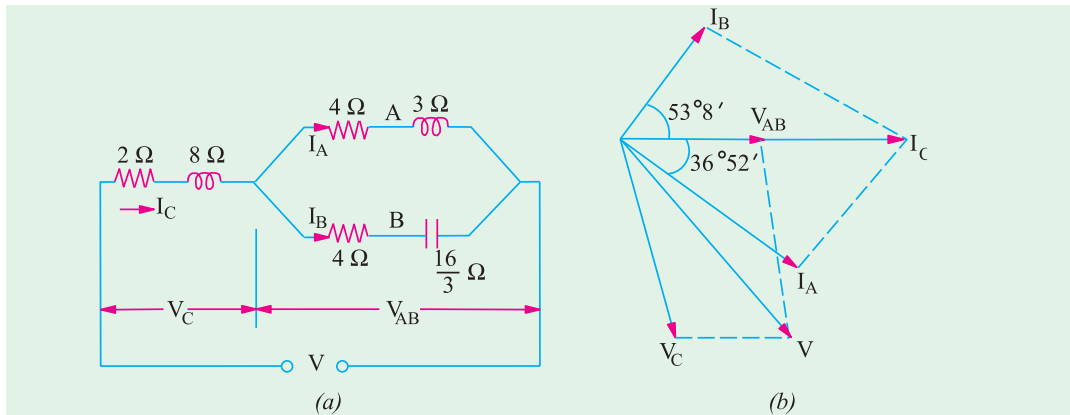

Fig. 14.38

**Example 14.33.** Find the value of the power developed in each arm of the series-parallel circuit shown in Fig. 14.39.

**Solution.** In order to find the circuit current, we must first find the equivalent impedance of the whole circuit.

$$Z_{AB} = (5 + j12) \parallel (-j20)$$

$$= \frac{(5 + j12)(-j20)}{5 + j12 - j20} = \frac{13 \angle 67.4^\circ \times 20 \angle -90^\circ}{9.43 \angle -58^\circ}$$

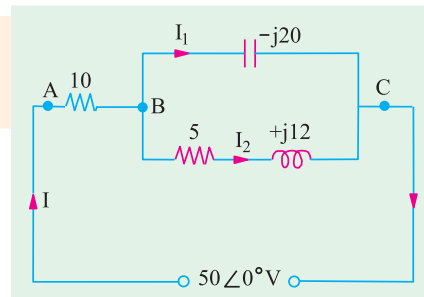

Fig. 14.39

$$= 27.57 \angle 35.4^\circ = (22.47 + j 15.97)$$

$$Z_{AC} = (10 + j0) + (22.47 + j15.97) = (32.47 + j14.97) \\ = 36.2 \angle 26.2^\circ$$

$$I = \frac{V}{Z} = \frac{50 \angle 0^\circ}{36.2 \angle 26.2^\circ} = 1.38 \angle -26.2^\circ \text{ A}$$

$$\text{Power developed in } 10 \Omega \text{ resistor} = I^2 R = 1.38^2 \times 10 = \mathbf{19 \text{ W}}$$

Potential difference across  $10 \Omega$  resistor is

$$IR = 1.38 \angle -26.2^\circ \times 10 = 13.8 \angle -26.2^\circ = (12.38 - j 6.1)$$

$$V_{BC} = \text{supply voltage} - \text{drop across } 10 \Omega \text{ resistor} \\ = (50 + j0) - (12.38 - j6.1) = (37.62 + j6.1) = 38.1 \angle 9.21^\circ$$

$$I_2 = \frac{V_{BC}}{(5 + j12)} = \frac{38.1 \angle 9.21^\circ}{13 \angle 67.4^\circ} = 2.93 \angle -58.2^\circ$$

$$\text{Power developed} = I_2^2 \times 5 = 2.93^2 \times 5 = \mathbf{43 \text{ W}}$$

No power is developed in the capacitor branch because it has no resistance.

**Example 14.34.** In the circuit shown in Fig. 14.40 determine the voltage at a frequency of 50 Hz to be applied across AB in order that the current in the circuit is 10 A. Draw the phasor diagram.

(Elect. Engg. & Electronics Bangalore Univ.)

$$\text{Solution. } X_{L1} = 2\pi \times 50 \times 0.05 = 15.71 \Omega; X_{L2} = -2\pi \times 50 \times 0.02 = 6.28 \Omega,$$

$$X_C = 1/2\pi \times 50 \times 400 \times 10^{-6} = 7.95 \Omega$$

$$Z_1 = R_1 + jX_{L1} = 10 + j15.71 = 18.6 \angle 57^\circ 33'$$

$$Z_2 = R_2 + jX_{L2} = 5 + j6.28 = 8 \angle 51^\circ 30'$$

$$Z_3 = R_3 - jX_C = 10 - j7.95 = 12.77 \angle -38^\circ 30'$$

$$Z_{BC} = Z_2 \parallel Z_3 = (5 + j6.28) \parallel (10 - j7.95) = 6.42 + j2.25 = 6.8 \angle 19^\circ 18'$$

$$Z = Z_1 + Z_{BC} = (10 + j15.71) + (6.42 + j2.25) = 16.42 + j17.96 = 24.36 \angle 47^\circ 36'$$

$$\text{Let } I = 10 \angle 0^\circ; \therefore V = IZ = 10 \angle 0^\circ \times 24.36 \angle 47^\circ 36' = 243.6 \angle 47^\circ 36'$$

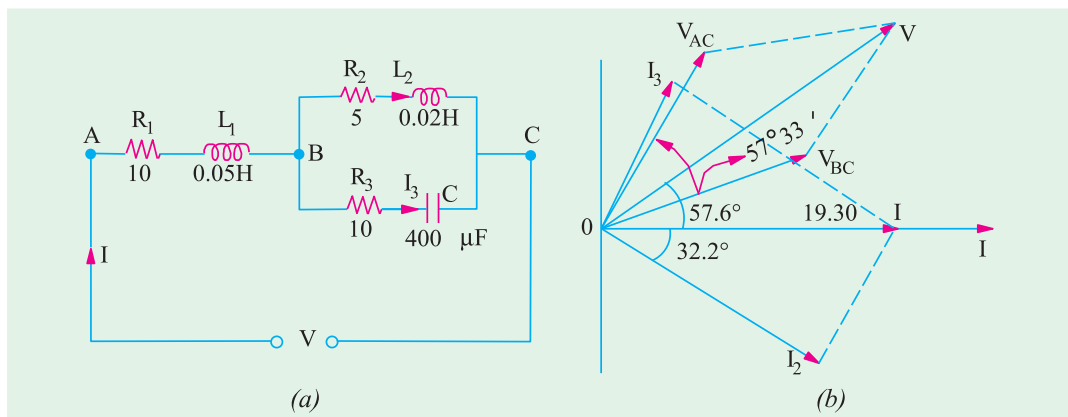

Fig. 14.40

$$V_{BC} = IZ_{BC} = 10 \angle 0^\circ \times 6.8 \angle 19^\circ 18' = 68 \angle 19^\circ 18'; I_2 = \frac{V_{BC}}{Z_2} = \frac{68 \angle 19^\circ 18'}{8 \angle 51^\circ 31'} = 8.5 \angle -32^\circ 12'$$

$$I_3 = \frac{V_{BC}}{Z_3} = \frac{68 \angle 19^\circ 18'}{12.77 \angle -38^\circ 30'} = 5.32 \angle 57^\circ 48'; V_{AC} = IZ_1 = 10 \angle 0^\circ \times 18.6 \angle 57^\circ 33' = 186 \angle 57^\circ 33'$$

The phasor diagram is shown in Fig. 14.36 (b).

**Example 14.35.** Determine the average power delivered to each of the three boxed networks in the circuit of Fig. 14.41. (Basic Circuit Analysis Osmania Univ. Jan/Feb 1992)

**Solution.**  $Z_1 = 6 - j8 = 10 \angle -53.13^\circ$ ;  $Z_2 = 2 + j14 = 14.14 \angle 81.87^\circ$ ;  $Z_3 = 6 - j8 = 10 \angle -53.13^\circ$

$$Z_{23} = \frac{Z_2 Z_3}{Z_2 + Z_3} = 14.14 \angle -8.13^\circ = 14 - j2$$

Drop across two parallel impedances is given by

$$V_{23} = 100 \frac{14 - j2}{(6 - j8) + (14 - j2)} = 63.2 \angle 18.43^\circ = 60 + j20$$

$$V_1 = 100 \frac{10 \angle -53.13^\circ}{6 - j8 + (14 - j2)} = 44.7 \angle -26.57^\circ = 40 - j20$$

$$I_1 = \frac{44.7 \angle -26.57^\circ}{10 \angle -53.13^\circ} = 4.47 \angle 26.56^\circ$$

$$I_2 = \frac{63.2 \angle 18.43^\circ}{14.14 \angle 81.87^\circ} = 4.47 \angle -63.44^\circ$$

$$I_3 = \frac{63.2 \angle 18.43^\circ}{10 \angle -53.13^\circ} = 6.32 \angle 71.56^\circ$$

$$P_1 = V_1 I_1 \cos \phi_1 = 44.7 \times 4.47 \times \cos 53.13^\circ = 120 \text{ W}$$

$$P_2 = V_2 I_2 \cos \phi_2 = 63.2 \times 4.47 \times \cos 81.87^\circ = 40 \text{ W};$$

$$P_3 = V_3 I_3 \cos \phi_3 = 63.2 \times 6.32 \times \cos 53.13^\circ = \mathbf{240 \text{ W}}, \text{ Total} = 400 \text{ W}$$

As a check, power delivered by the 100-V source is,

$$P = VI \cos \phi = 100 \times 4.47 \times \cos 26.56^\circ = 400 \text{ W}$$

**Example 14.36.** In a series-parallel circuit of Fig. 14.42 (a), the parallel branches A and B are in series with C. The impedances are  $Z_A = (4 + j3)$ ,  $Z_B = (10 - j7)$  and  $Z_C = (6 + j5) \Omega$ .

If the voltage applied to the circuit is 200 V at 50 Hz, calculate: (a) current  $I_A$ ,  $I_B$  and  $I_C$ ; (b) the total power factor for the whole circuit.

Draw and explain complete vector diagram.

**Solution.**  $Z_A = 4 + j3 = 5 \angle 36.9^\circ$ ;  $Z_B = 10 - j7 = 12.2 \angle -35^\circ$ ;  $Z_C = 6 + j5 = 7.8 \angle 39.8^\circ$

$$Z_{AB} = \frac{Z_A Z_B}{Z_A + Z_B} = \frac{5 \angle 36.9^\circ \cdot 12.2 \angle -35^\circ}{14 \angle j4} = \frac{61 \angle 1.9^\circ}{14.56} = 4.19 \angle 9.4^\circ = 4 + j1.3$$

$$Z = Z_C + Z_{AB} = (6 + j5) + (4 + j1.3) = 10 + j6.3 = 11.8 \angle 32.2^\circ$$

Let  $V = 200 \angle 0^\circ$ ;  $I_C = (V/Z) = (200/11.8) \angle 32.2^\circ = 16.35 \angle -32.2^\circ$

$$I_A = I_C \cdot \frac{Z_B}{Z_A + Z_B} = 16.35 \angle -32.2^\circ \cdot \frac{12.2 \angle -35^\circ}{14.56 \angle 16^\circ} = 13.7 \angle -32.2^\circ$$

$$I_B = I_C \cdot \frac{Z_A}{Z_A + Z_B} = 16.35 \angle -32.2^\circ \cdot \frac{5 \angle 36.9^\circ}{14.56} = 5.7 \angle 20.7^\circ$$

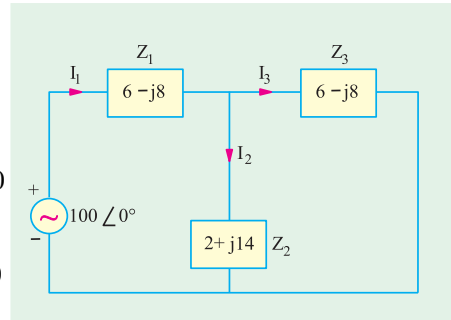

Fig. 14.41

The phase angle between  $V$  and total circuit current  $I_C$  is  $32.2^\circ$ . Hence p.f. for the whole circuit is  $\cos 32.2^\circ = 0.846$  (lag)

For drawing the phasor diagram of Fig. 14.42 (b) following quantities have to be calculated :

$$V_C = I_C Z_C = 16.35 \angle -32.2^\circ \times 7.8 \angle 39.8^\circ = 127.53 \angle 7.6^\circ$$

$$V_{AB} = I_C Z_{AB} = 16.35 \angle -32.2^\circ \times 4.19 \angle 17.9^\circ = 18.5 \angle -14.3^\circ$$

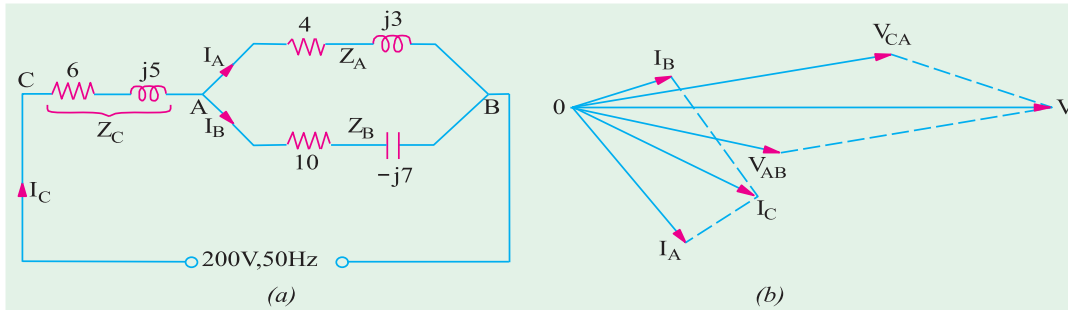

Fig. 14.42

The circuit and phasor diagrams are shown in Fig. 14.38.

**Example 14.37.** A fluorescent lamp taking 80 W at 0.7 power factor lagging from a 230-V 50-Hz supply is to be corrected to unity power factor. Determine the value of the correcting apparatus required.

**Solution.** Power taken by the 80-W lamp circuit can be found from the following equation,

$$230 \times I \times 0.7 = 80 \quad \therefore I = 80/230 \times 0.7 = 0.5 \text{ A}$$

Reactive component of the lamp current is  $I \sin \phi = 0.5 \sqrt{1 - 0.7^2} = 0.357 \text{ A}$

The power factor of the lamp circuit may be raised to unity by connecting a suitable capacitor across the lamp circuit. The leading reactive current drawn by it should be just equal to 0.357 A. In that case, the two will cancel out leaving only the in-phase component of the lamp current.

$$I_C = 0.357 \text{ A}, \quad X_C = 230/0.357 = 645 \Omega$$

$$\text{Now } X_C = 1/\omega C \quad \therefore 645 = 1/2\pi \times 50 \times C, \quad C = 4.95 \mu\text{F}$$

**Example 14.38.** For the circuit shown in Fig. 14.43, calculate  $I_1$ ,  $I_2$  and  $I_3$ . The values marked on the inductance and capacitance give their reactances. (Elect. Science-I Allahabad Univ. 1992)

$$\text{Solution. } Z_{BC} = Z_2 \parallel Z_3 = \frac{(4 + j2)(1 - j5)}{(3 + j2) + (1 - j5)} = \frac{14 - j18}{5 - j3} = \frac{(14 - j18)(5 + j3)}{5^2 + 3^2} = 3.65 - j1.41 = 3.9 \angle 21.2^\circ$$

$$Z = Z_1 + Z_{BC} = (2 + j3) + (3.65 - j1.41) = 5.65 + j1.59 = 5.82 \angle 74.3^\circ$$

$$\text{Let } V = 10 \angle 0^\circ; \quad I_1 = V/Z = 10 \angle 0^\circ / 5.82 \angle 74.3^\circ = 1.72 \angle -74.3^\circ$$

$$V_{BC} = I_1 Z_{BC} = 1.72 \angle -74.3^\circ \times 3.9 \angle 21.2^\circ = 6.7 \angle -53.1^\circ$$

$$\text{Now, } Z_2 = 4 + j2 = 4.47 \angle 63.4^\circ;$$

$$Z_3 = 1 - j5 = 5.1 \angle -11.3^\circ$$

$$I_2 = V_{BC}/Z_2 = 6.7 \angle -53.1^\circ / 4.47 \angle 63.4^\circ = 1.5 \angle -10.3^\circ$$

$$I_3 = V_{BC}/Z_3 = 6.7 \angle -53.1^\circ / 5.1 \angle -11.3^\circ = 1.3 \angle -41.8^\circ$$

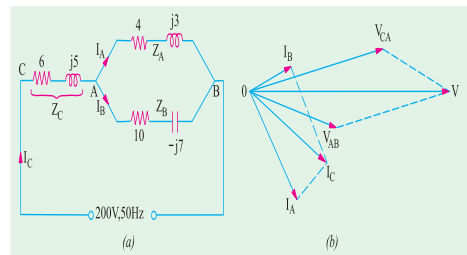

Fig. 14.43

**Example 14.39.** A workshop has four 240-V, 50-Hz single-phase motors each developing 3.73 kW having 85% efficiency and operating at 0.8 power factor. Calculate the values 0.9 lagging and (b) 0.9 leading. For each case, sketch a vector diagram and find the value of the supply current.

**Solution.** Total motor power input =  $4 \times 3730/0.85 = 17,550$  W

Motor current  $I_m = 17,550/240 \times 0.8 = 91.3$  A

Motor p.f. =  $\cos \phi_m = 0.8 \therefore \phi_m = \cos^{-1}(0.8) = 36^\circ 52'$

(a) Since capacitor does not consume any power, the power taken from the supply remains unchanged after connecting the capacitor. If  $I_s$  is current drawn from the supply, then  $240 \times I_s \times 0.9 = 17,550$

$\therefore I_s = 81.2$  A,  $\cos \phi_s = 0.9$ ;  $\phi_s = \cos^{-1}(0.9) = 25^\circ 50'$

As seen from vector diagram of Fig. 14.44 (a),  $I_s$  the vector sum of  $I_m$  and capacitor current  $I_C$ ,  $I_C = I_m \sin \phi_m - I_s \sin \phi_s = 91.3 \sin 36^\circ 52' - 81.2 \sin 25^\circ 50' = 54.8 - 35.4 = 19.4$  A

Now  $I_C = \omega VC$

or  $19.4 = 240 \times 2\pi \times 50 \times C$

$\therefore C = 257 \times 10^{-6} \text{ F} = 257 \mu\text{F}$

(b) In this case,  $I_s$  leads the supply voltage as shown in Fig. 14.44 (b)

$$I_C = I_m \sin \phi_m + I_s \sin \phi_s = 54.8 + 35.4 = 90.2 \text{ A}$$

Now  $I_C = \omega VC$

$\therefore 90.2 = 240 \times 2\pi \times 50 \times C$

$\therefore C = 1196 \times 10^{-6} \text{ F} = 1196 \mu\text{F}$

The line or supply current is, as before, 81.2 A (leading)

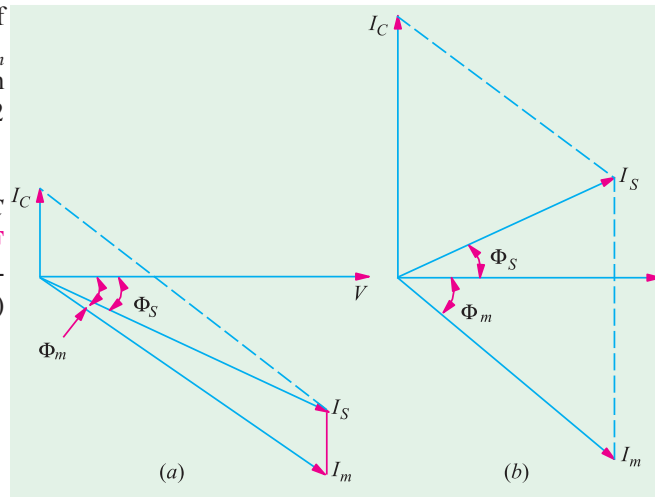

Fig. 14.44

**Example 14.40.** The load taken from a supply consists of (a) lamp load 10 kW a unity power factor (b) motor load of 80 kVA at 0.8 power factor (lag) and (c) motor load of 40 kVA at 0.7 power factor leading. Calculate the total load taken from the supply in kW and in kVA and the power factor of the combined load.

**Solution.** Since it is more convenient to adopt the tabular method for such questions, we will use the same as illustrated below. We will tabulate the kW, kVA and kVAR (whether leading or lagging) of each load. The lagging kVAR will be taken as negative and leading kVAR as positive.

Load	kVA	$\cos \phi$	$\sin \phi$	kW	kVAR
(a)	10	1	0	10	0
(b)	80	0.8	0.6	64	-48
(c)	40	0.7	0.714	28	28/6
<b>Total</b>				<b>102</b>	<b>-19.2</b>

Total kW = 102 ; Total kVAR = -19.4 (lagging) ; kVA taken =  $\sqrt{102^2 + (-19.4)^2} = 103.9$

Power factor = kW/kVA =  $102/103.9 = 0.9822$  (lag)

**Example 14.41.** A 23-V, 50 Hz, 1-ph supply is feeding the following loads which are connected across it.

(i) A motor load of 4 kW, 0.8 lagging p.f.

(ii) A rectifier of 3 kW at 0.6 leading p.f.

(iii) A lighter-load of 10 kVA at unity p.f.

(iv) A pure capacitive load of 8 kVA

Determine : Total kW, Total kVAR, Total kVA

(I BE Nagpur University Nov. 1999)

**Solution.**

S. No.	Item	kW	P.f	kVA	kVAR	I	$I_s$	$I_r$
1	Motor	4	0.8 lag	5	3 -ve, Lag	21.74	17.4	13.04 Lag (-)
2	Rectifier	3	0.6 Lead	5	4 + ve, Lead	21.74	13.04	17.4 Lead (+)
3	Light-Load	10	1.0	10	zero	43.48	43.48	zero
4	Capacitive Load	Zero	0.0 Lead	8	8 + ve Lead	34.8	zero	34.8 Lead (+)
	Total	17	-	Phasor Addition required	+ 9 + ve Lead	Phasor addition required	73.92	39.16 Lead (+)

Performing the calculations as per the tabular entries above, following answers are obtained  
Total kW = 17

Total kVAR = + 9, leading

$$\text{Total kVA} = \sqrt{17^2 + 9^2} = 19.2354$$

$$\text{Overall circuit p.f.} = \frac{\text{kW}}{\text{kVA}} = \frac{17}{19.2354} = 0.884 \text{ leading}$$

$$\text{Overall Current} = \frac{19235.4}{230} = 83.63 \text{ amp}$$

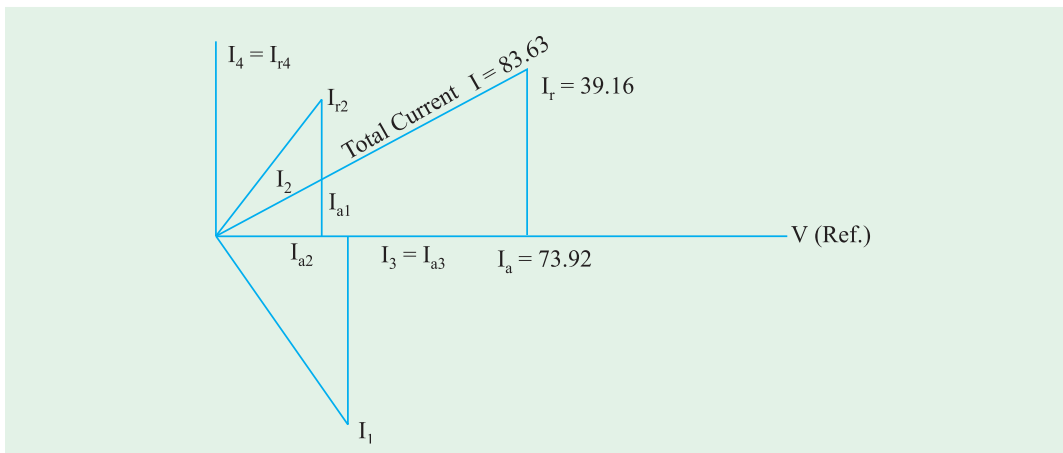

**Fig. 14.45** Phasor diagram for currents corresponding to load

**Example 14.42.** A three phase induction Motor delivers an output of 15 h.p. at 83 % efficiency. The motor is  $\Delta$  (delta) connected and is supplied by 440 V, three phase, 50 Hz supply. Line current drawn by motor is 22.36 Amp. What is motor power factor ?

It is now decided to improve the power factor to 0.95 lag by connecting three similar capacitors in delta across the supply terminals. Determine the value of the capacitance of each capacitor.

[Note : 1 h.p. = 745 watts]

(Bombay University, 2000)

**Solution.** Power factor =  $\frac{15 \times 745}{0.83 \times 1.732 \times 440 \times 22.36} = 0.79$ , Lagging

$$\phi = \cos^{-1} 0.79 = 37.8^\circ$$

$$I_1 = I_{ph} = 22.36/1.732 = 12.91 \text{ amp}$$

Active Current  $I_a = I_1 \cos \phi_1 = 12.91 \times 0.79 = 10.2 \text{ amp}$

New Power-factor  $\cos \phi_2 = 0.95, \phi_2 = 18.2^\circ$   
 $I_2 = 10.2/0.95 = 10.74$  amp  
 Capacitive current per phase  $= I_1 \sin \phi_1 - I_2 \sin \phi_2$   
 $= 4.563$   
 Capacitive reactance per phase  $= 440/4.563 = 96.43$  ohms  
 Capacitance per phase  $= 33 \mu\text{f}$   
 These have to be delta-connected



Three phase induction motor

**Example 14.43.** Draw admittance triangle between the terminals AB of Fig 14.46 (a) labelling its sides with appropriate values and units in case of :

- (i)  $X_L = 4$  and  $X_C = 8$     (ii)  $X_L = 10$  and  $X_C = 5$

[Bombay University 1999]

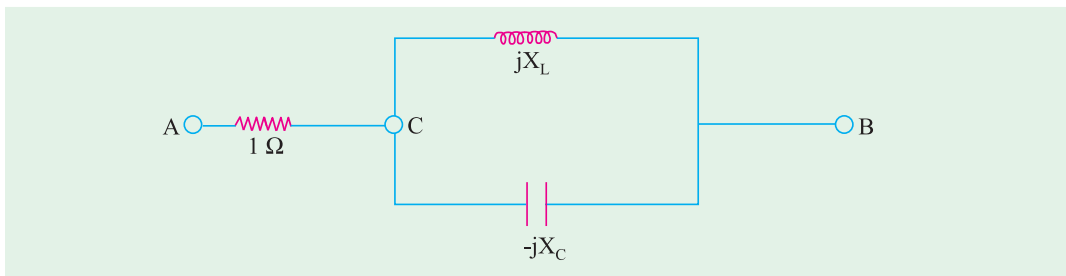

Fig. 14.46 (a)

**Solution. (i)**

$$X_L = 4 \Omega, X_C = 8 \Omega$$

$$Z_{CB} = \frac{jX_L (-jX_C)}{j(X_L - X_C)} = j8$$

$$Z_{AB} = 1 + j8 \text{ ohms}$$

$$Y_{AB} = 1/Z_{AB} = (1/65) - j(8/65) \text{ mho}$$

**(ii)**

$$X_L = 10 \Omega, X_C = 5 \Omega$$

$$Z_{CB} = \frac{j10 \times (-j5)}{j5} = -j10$$

$$Z_{AB} = 1 - j10 \text{ ohms}$$

$$Y_{AB} = (1/101) + j(10/101) \text{ mho}$$

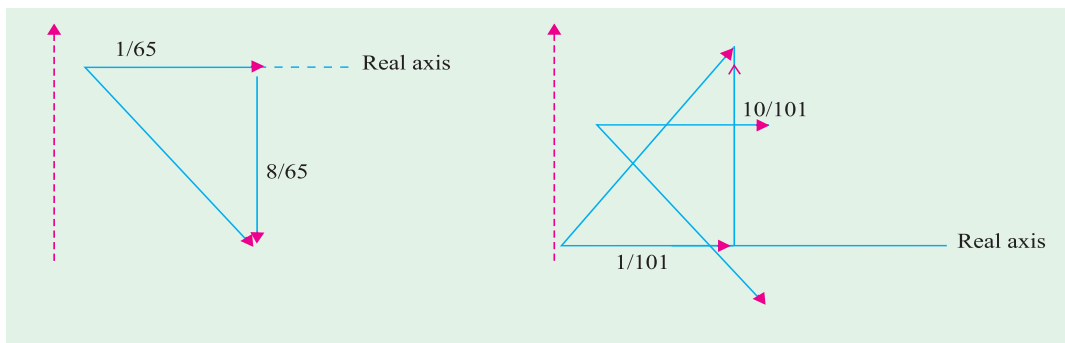

(i) Admittance triangle for first case

Fig. 14.46 (b)

(ii) Admittance triangle for second case

Fig. 14.46 (c)

**Example 14.44.** For the circuit in Fig. 14.47 (a), given that  $L = 0.159 \text{ H}$

$$C = 0.3183 \text{ mf}$$

$$I_2 = 5 \angle 60^\circ \text{ A}$$

$$V_1 = 250 \angle 90^\circ \text{ volts.}$$

**Find :-**

- (i) Impedance  $Z_1$  with its components.
- (ii) Source voltage in the form of  $V_m \cos(\omega t + \phi)$ .
- (iii) Impedance  $Z_2$  with its components so that source p.f. is unity, without adding to the circuit power loss.
- (iv) Power loss in the circuit
- (v) Draw the phasor diagram.

(Bombay University 1997)

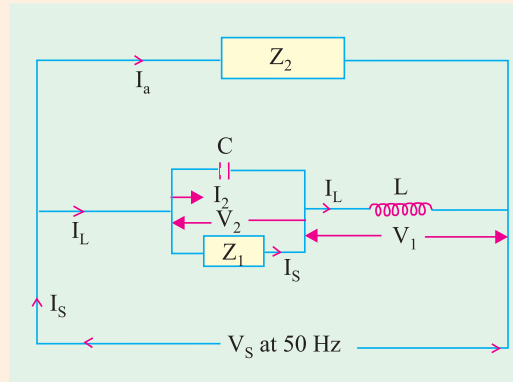

Fig. 14.47 (a)

**Solution.**  $X_L = 314 \times 0.159 = 50 \text{ ohms}$

$$X_C = 1/(314 \times 0.3183 \times 10^{-3}) = 10 \text{ ohms}$$

$$I_L = V_1/jX_L = (250 \angle 90^\circ) / (50 \angle 90^\circ) = 5 \angle 0^\circ \text{ amps}$$

$$V_2 = -jI_2 X_C = (5 \angle 60^\circ) \times (10 \angle -90^\circ) = 50 \angle -30^\circ \text{ volts} = 43.3 - j25 \text{ volts}$$

$$\begin{aligned} I_1 &= I_L - I_2 = 5 \angle 0^\circ - 5 \angle 60^\circ = 5 + j0 - 5(0.5 + j0.866) \\ &= 2.5 - j4.33 = 5 \angle -60^\circ \end{aligned}$$

$$\begin{aligned} \text{(a)} \quad Z_1 &= V_2/I_1 = (50 \angle -30^\circ) / 5 \angle -60^\circ = 10 \angle +30^\circ \\ &= 10(\cos 30^\circ + j \sin 30^\circ) = 8.66 + j5 \end{aligned}$$

$$\begin{aligned} \text{(b)} \quad V_s &= V_1 + V_2 = 0 + j250 + 43.3 - j25 = 43.3 + j225 \\ &= 229.1 \angle 79.1^\circ \text{ volts} \end{aligned}$$

$$V_s \text{ has a peak value of } (229.1 \times \sqrt{2}) = 324 \text{ volts}$$

$$V_s = 324 \cos(314t - 10.9^\circ), \text{ taking } V_1 \text{ as reference}$$

or  $V_s = 325 \cos(314t - 79.1^\circ), \text{ taking } I_L \text{ as reference.}$

(c) Source Current must be at unity P.f., with  $V_s$

$$\text{Component of } I_L \text{ in phase with } V_s = 5 \cos 79.1^\circ = 0.9455 \text{ amp}$$

$$\text{Component of } I_L \text{ in quadrature with } V_s \text{ (and is lagging by } 90^\circ)$$

$$= 5.00 \times \sin 79.1^\circ = 4.91 \text{ amp}$$

$Z_2$  must carry  $I_a$  such that no power loss is there and  $I_s$  is at unity P.f. with  $V_s$ .

$I_a$  has to be capacitive, to compensate, in magnitude, the quadrature component of  $I_L$

$$|I_a| = 4.91 \text{ amp}$$

$$|Z_2| = V_s / |I_a| = 229.1/4.91 = 46.66 \text{ ohms}$$

$$\text{Corresponding capacitance, } C_2 = 1 / (46.66 \times 314) = 68.34 \mu\text{F}$$

(d) Power-loss in the circuit  $= I_1^2 \times 8.66 = 216.5 \text{ watts}$  or power  $= V_s \times \text{component of } I_L \text{ in phase with } V_s = 229.1 \times 0.9455 = 216.5 \text{ watts}$

(e) Phasor diagram is drawn in Fig. 14.47 (b)

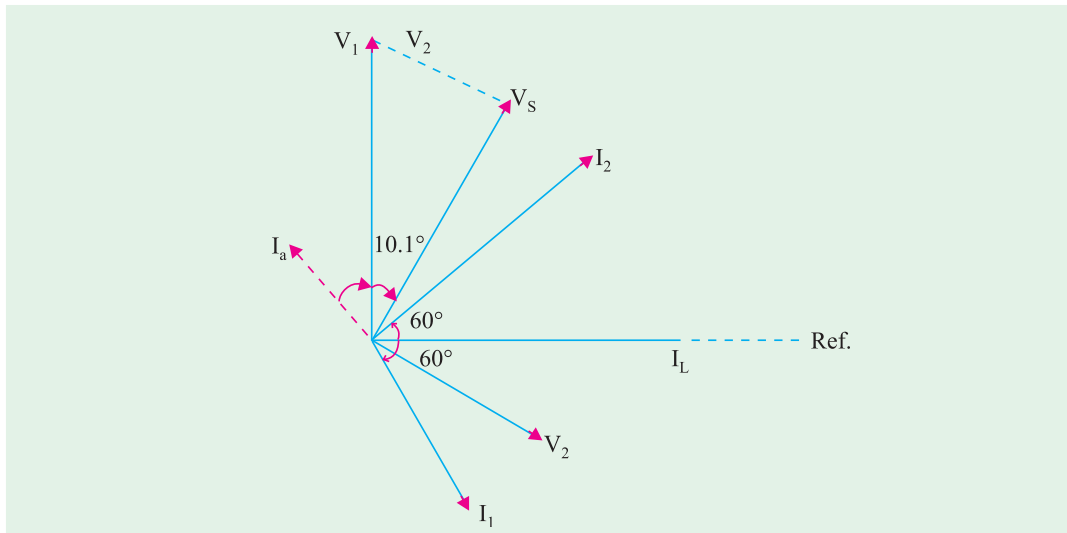

Fig. 14.47 (b) Phasor diagram

### Tutorial Problem No. 14.1

- A capacitor of  $50 \mu\text{F}$  capacitance is connected in parallel with a reactor of  $22 \Omega$  resistance and  $0.07$  henry inductance across  $200\text{-V}$ ,  $50\text{-Hz}$  mains. Calculate the total current taken. Draw the vector diagram in explanation.  
**[4.76 A lagging,  $17^\circ 12'$ ] (City & Guilds, London)**
- A non-inductive resistor is connected in series with a capacitor of  $100 \mu\text{F}$  capacitance across  $200\text{-V}$ ,  $50\text{-Hz}$  mains. The p.d. measured across the resistor is  $150 \text{ V}$ . Find the value of resistance and the value of current taken from the mains if the resistor were connected in parallel-with the capacitor instead of in series.  
**[R =  $36.1 \Omega$ ;  $8.37 \text{ A}$ ] (City & Guilds, London)**
- An impedance of  $(10 + j15) \Omega$  is connected in parallel with an impedance of  $(6 - j8) \Omega$ . The total current is  $15 \text{ A}$ . Calculate the total power.  
**[2036 W] (City & Guilds, London)**
- The load on a  $250\text{-V}$  supply system is :  $12 \text{ A}$  at  $0.8$  power factor lagging ;  $10 \text{ A}$  at  $0.5$  power factor lagging ;  $15 \text{ A}$  at unity power factor ;  $20 \text{ A}$  at  $0.6$  power factor leading. Find (i) the total load in kVA and (ii) its power factor.  
**[(i)  $10.4 \text{ kVA}$  (ii)  $1.0$ ] (City & Guilds, London)**
- A voltage having frequency of  $50 \text{ Hz}$  and expressed by  $V = 200 + j100$  is applied to a circuit consisting of an impedance of  $50 \angle 30^\circ \Omega$  in parallel with a capacitance of  $10 \mu\text{F}$ . Find (a) the reading on an ammeter connected in the supply circuit (b) the phase difference between the current and the voltage.  
**[(a)  $4.52$  (b)  $26.6^\circ$  lag] (London University)**
- A voltage of  $200^\circ \angle 30^\circ \text{ V}$  is applied to two circuits  $A$  and  $B$  connected in parallel. The current in  $A$  is  $20 \angle 60^\circ \text{ A}$  and that in  $B$  is  $40 \angle -30^\circ \text{ A}$ . Find the kVA and kW in each branch circuit and the main circuit. Express the current in the main circuit in the form  $A + jB$ .  
**[kVA<sub>A</sub> =  $4$ , kVA<sub>B</sub> =  $8$ , kVA =  $12$ , kW<sub>A</sub> =  $3.46$ , kW<sub>B</sub> =  $4$ , kW =  $7.46$ , I =  $44.64 - j 2.68$ ] (City & Guilds, London)**
- A coil having an impedance of  $(8 + j6) \Omega$  is connected across a  $200\text{-V}$  supply. Express the current in the coil in (i) polar and (ii) rectangular co-ordinate forms.  
 If a capacitor having a susceptance of  $0.1 \text{ S}$  is placed in parallel with the coil, find (iii) the magnitude of the current taken from the supply.  
**[(i)  $20 \angle 36.8^\circ \text{ A}$  (ii)  $16 - j12 \text{ A}$  (iii)  $17.9 \text{ A}$ ] (City & Guilds, London)**
- A coil-A of inductance  $80 \text{ mH}$  and resistance  $120 \Omega$  is connected to a  $230\text{-V}$ ,  $50 \text{ Hz}$  single-phase supply. In parallel with it is a  $16 \mu\text{F}$  capacitor in series with a  $40 \Omega$  non-inductive resistor  $B$ . Determine (i) the power factor of the combined circuit and (ii) the total power taken from the supply.  
**[(i)  $0.945$  lead (ii)  $473 \text{ W}$ ] (London University)**
- A choking coil of inductance  $0.08 \text{ H}$  and resistance  $12 \text{ ohm}$ , is connected in parallel with a capacitor

of  $120\ \mu\text{F}$ . The combination is connected to a supply at 240 V, 50 Hz. Determine the total current from the supply and its power factor. Illustrate your answers with a phasor diagram.

[3.94 A, 0.943 lag] (*London University*)

10. A choking coil having a resistance of  $20\ \Omega$  and an inductance of 0.07 henry is connected with a capacitor of  $60\ \mu\text{F}$  capacitance which is in series with a resistor of  $50\ \Omega$ . Calculate the total current and the phase angle when this arrangement is connected to 200-V, 50 Hz mains.  
[7.15 A,  $24^\circ 39'$  lag] (*City & Guilds, London*)
11. A coil of resistance  $15\ \Omega$  and inductance 0.05 H is connected in parallel with a non-inductive resistance of  $20\ \Omega$ . Find (a) the current in each branch (b) the total current (c) the phase angle of whole arrangement for an applied voltage of 200 V at 50 Hz.  
[9.22 A ; 10 A ;  $22.1^\circ$ ]
12. A sinusoidal 50-Hz voltage of 200 V (r.m.s) supplies the following three circuits which are in parallel : (a) a coil of inductance 0.03 H and resistance  $3\ \Omega$  (b) a capacitor of  $400\ \mu\text{F}$  in series with a resistance of  $100\ \Omega$  (c) a coil of inductance 0.02 H and resistance  $7\ \Omega$  in series with a  $300\ \mu\text{F}$  capacitor. Find the total current supplied and draw a complete vector diagram.  
[29.4 A] (*Sheffield Univ. U.K.*)
13. A 50-Hz, 250-V single-phase power line has the following loads placed across it in parallel : 4 kW at a p.f. of 0.8 lagging ; 6 kVA at a p.f. of 0.6 lagging; 5 kVA which includes 1.2 kVAR leading. Determine the overall p.f. of the system and the capacitance of the capacitor which, if connected across the mains would restore the power factor to unity.  
[0.844 lag ; 336  $\mu\text{F}$ ]
14. Define the terms admittance, conductance and susceptance with reference to alternating current circuits. Calculate their respective values for a circuit consisting of resistance of  $20\ \Omega$ , in series with an inductance of 0.07 H when the frequency is 50 Hz.  
[0.336 S, 0.0226 S, 0.0248 S]  
(*City & Guilds, London*)
15. Explain the terms admittance, conductance, susceptance as applied to a.c. circuits. One branch A, of a parallel circuit consists of a coil, the resistance and inductance of which are  $30\ \Omega$  and 0.1 H respectively. The other branch B, consists of a  $100\ \mu\text{F}$  capacitor in series with a  $20\ \Omega$  resistor. If the combination is connected 240-V, Hz mains, calculate (i) the line current and (ii) the power. Draw to scale a vector diagram of the supply current and the branch-circuit currents.  
[(i) 7.38 A (ii) 1740 W] (*City & Guilds, London*)
16. Find the value of capacitance which when placed in parallel with a coil of resistance  $22\ \Omega$  and inductance of 0.07 H, will make it resonate on a 50-Hz circuit.  
[72.33  $\mu\text{F}$ ] (*City & Guilds, London*)
17. A parallel circuit has two branches. Branch A consists of a coil of inductance 0.2 H and a resistance of  $15\ \Omega$  ; branch B consists of a 30 mF capacitor in series with a  $10\ \Omega$  resistor. The circuit so formed is connected to a 230-V, 50-Hz supply. Calculate (a) current in each branch (b) line current and its power factor (c) the constants of the simplest series circuit which will take the same current at the same power factor as taken by the two branches in parallel.  
[3.57 A, 2.16 A ; 1.67 A, 0.616 lag, 8.48  $\Omega$  0.345 H]
18. A 3.73 kW, 1-phase, 200-V motor runs at an efficiency of 75% with a power factor of 0.7 lagging. Find (a) the real input power (b) the kVA taken (c) the reactive power and (d) the current. With the aid of a vector diagram, calculate the capacitance required in parallel with the motor to improve the power factor to 0.9 lagging. The frequency is 50 Hz.  
[4.97 kW ; 7.1 kVA ; 5.07 kVAR ; 35.5 A ; 212  $\mu\text{F}$ ]
19. The impedances of two parallel circuits can be represented by  $(20 + j15)$  and  $(1 - j60)\ \Omega$  respectively. If the supply frequency is 50 Hz, find the resistance and the inductance or capacitance of each circuit. Also derive a symbolic expression for the admittance of the combined circuit and then find the phase angle between the applied voltage and the resultant current. State whether this current is leading or lagging relatively to the voltage. [20  $\Omega$  ; 0.0478 H ; 10  $\Omega$  ; 53  $\mu\text{F}$  ;  $(0.0347 - j 0.00778)\text{S}$  ;  $12^\circ 38'$  lag]
20. One branch A of a parallel circuit consists of a  $60\text{-}\mu\text{F}$  capacitor. The other branch B consists of a  $30\ \Omega$  resistor in series with a coil of inductance 0.2 H and negligible resistance. A  $140\ \Omega$  resistor is connected in parallel with the coil. Sketch the circuit diagram and calculate (i) the current in the  $30\ \Omega$  resistor and (ii) the line current if supply voltage is 230-V and the frequency 50 Hz.  
[(i) 3.1  $\angle 44^\circ$  (ii) 3.1  $\angle 45^\circ$  A]
21. A coil having a resistance of  $45\ \Omega$  and an inductance of 0.4 H is connected in parallel with a capacitor having a capacitance of  $20\ \mu\text{F}$  across a 230-V, 50-Hz system. Calculate (a) the current taken from the

- supply (b) the power factor of the combination and (c) the total energy absorbed in 3 hours.  
**[(a) 0.615 (b) 0.951 (c) 0.402 kWh] (London University)**
22. A series circuit consists of a resistance of  $10\ \Omega$  and reactance of  $5\ \Omega$ . Find the equivalent value of conductance and susceptance in parallel.  
**[0.08 S, 0.04 S]**
23. An alternating current passes through a non-inductive resistance  $R$  and an inductance  $L$  in series. Find the value of the non-inductive resistance which can be shunted across the inductance without altering the value of the main current.  
 **$[\omega^2 L^2 / 2R]$  (Elec. Meas. London Univ.)**
24. A p.d. of 200 V at 50 Hz is maintained across the terminals of a series-parallel circuit, of which the series branch consists of an inductor having an inductance of 0.15 H and a resistance of  $30\ \Omega$ , one parallel branch consists of  $100\text{-}\mu\text{F}$  capacitor and the other consists of a  $40\text{-}\Omega$  resistor. Calculate (a) the current taken by the capacitor (b) the p.d. across the inductor and (c) the phase difference of each of these quantities relative to the supply voltage. Draw a vector diagram representing the various voltage and currents.  
**[(a) 29.5 A (b) 210 V (c) 7.25°, 26.25°] (City & Guilds, London)**
25. A coil (A) having an inductance of 0.2 H and resistance of  $3.5\ \Omega$  is connected in parallel with another coil (B) having an inductance of 0.01 H and a resistance of  $5\ \Omega$ . Calculate (i) the current and (ii) the power which these coils would take from a 100-V supply system having a frequency of 50-Hz. Calculate also (iii) the resistance and (iv) the inductance of a single coil which would take the same current and power.  
**[(i) 29.9 A (ii) 2116 W (iii) 2.365  $\Omega$  (iv) 0.00752 H] (London Univ.)**
26. Two coils, one (A) having  $R = 5\ \Omega$ ,  $L = 0.031\ \text{H}$  and the other (B) having  $R = 7\ \Omega$ ;  $L = 0.023\ \text{H}$ , are connected in parallel to an a.c. supply at 200 V, 50 Hz. Determine (i) the current taken by each coil and also (ii) the resistance and (iii) the inductance of a single coil which will take the same total current at the same power factor as the two coils in parallel.  
**[(i)  $I_A = 18.28\ \text{A}$ ,  $I_B = 19.9\ \text{A}$  (ii) 3.12  $\Omega$  (iii) 0.0137 H] (London Univ.)**
27. Two coils are connected in parallel across 200-V, 50-Hz mains. One coil takes 0.8 kW and 1.5 kVA and the other coil takes 1.0 kW and 0.6 kVAR. Calculate (i) the resistance and (ii) the reactance of a single coil which would take the same current and power as the original circuit.  
**[(i) 10.65  $\Omega$  (ii) 11.08  $\Omega$ ] (City & Guilds, London)**
28. An a.c. circuit consists of two parallel branches, one (A) consisting of a coil, for which  $R = 20\ \Omega$  and  $L = 0.1\ \text{H}$  and the other (B) consisting of a  $40\text{-}\Omega$  non-inductive resistor in series with  $60\text{-}\mu\text{F}$  capacitor. Calculate (i) the current in each branch (ii) the line current (iii) the power, when the circuit is connected to 230-V mains having a frequency of 50 Hz. Calculate also (iv) the resistance and (b) the inductance of a single coil which will take the same current and power from the supply.  
**[(i) 6.15 A, 3.46 A (ii) 5.89 (iii) 1235 W (iv) 35.7  $\Omega$  (b) 0.0509 H] (London Univ.)**
29. One branch (A) of a parallel circuit, connected to 230-V, 50-Hz mains consists of an inductive coil ( $L = 0.15\ \text{H}$ ,  $R = 40\ \Omega$ ) and the other branch (B) consists of a capacitor ( $C = 50\ \mu\text{F}$ ) in series with a  $45\ \Omega$  resistor. Determine (i) the power taken (ii) the resistance and (iii) the reactance of the equivalent series circuit.  
**[(i) 946 W (ii) 55.4  $\Omega$  (iii) 4.6  $\Omega$ ] (London Univ.)**

### 14.9. Resonance in Parallel Circuits

We will consider the practical case of a coil in parallel with a capacitor, as shown in Fig. 14.48. Such a circuit is said to be in electrical resonance when the reactive (or wattless) component of line current becomes zero. The frequency at which this happens is known as *resonant* frequency.

The vector diagram for this circuit is shown in Fig. 14.48 (b).

$$\begin{aligned} \text{Net reactive or wattless component} \\ = I_C - I_L \sin \phi_L \end{aligned}$$

As at resonance, its value is zero, hence

$$I_C - I_L \sin \phi_L = 0 \text{ or } I_L \sin \phi_L = I_C$$

$$\text{Now, } I_L = V/Z; \sin \phi_L = X_L \text{ and } I_C = V/X_C$$

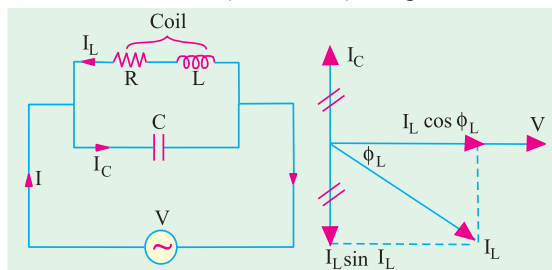

Fig. 14.48

Hence, condition for resonance becomes

$$\frac{V}{Z} \times \frac{X_L}{Z} = \frac{V}{X_C} \quad \text{or} \quad X_L \times X_C = Z^2$$

$$\text{Now, } X_L = \omega L, X_C = \frac{1}{\omega C}$$

$$\therefore \frac{\omega L}{\omega C} = Z^2 \quad \text{or} \quad \frac{L}{C} = Z^2 \quad \dots (i)$$

$$\text{or} \quad \frac{L}{C} = R^2 + X_L^2 = R^2 + (2\pi f_0 L)^2$$

$$\text{or} \quad (2\pi f_0 L)^2 = \frac{L}{C} - R^2 \quad \text{or} \quad 2\pi f_0 = \sqrt{\frac{1}{LC} - \frac{R^2}{L^2}} \quad \text{or} \quad f_0 = \frac{1}{2} \sqrt{\frac{1}{LC} - \frac{R^2}{L^2}}$$

This is the resonant frequency and is given in Hz,  $R$  is in ohm,  $L$  is the henry and  $C$  is the farad.

If  $R$  is the negligible, then  $f_0 = \frac{1}{2\pi\sqrt{LC}}$

... same as for series resonance

### Current at Resonance

As shown in Fig. 14.41 (b), since wattless component of the current is zero, the circuit current is

$$I = I_L \cos \phi_L = \frac{V}{Z} \cdot \frac{R}{Z} \quad \text{or} \quad I = \frac{VR}{Z^2}$$

Putting the value of  $Z^2 = L/C$  from (i) above, we get  $I = \frac{VR}{L/C} = \frac{V}{L/CR}$

The denominator  $L/CR$  is known as the **equivalent** or **dynamic impedance** of the parallel circuit at resonance. It should be noted that impedance is ‘resistive’ only. Since current is minimum at resonance,  $L/CR$  must, therefore, represent the maximum impedance of the circuit. In fact, parallel resonance is a condition of maximum impedance or minimum admittance.

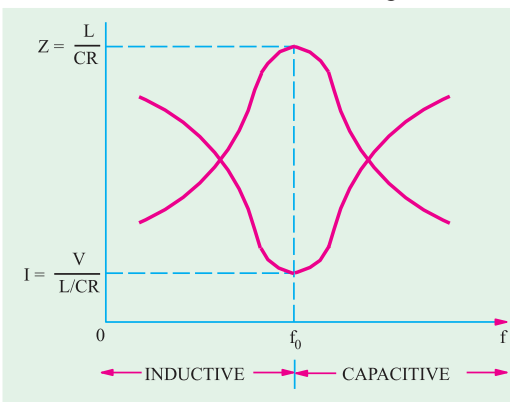

Fig. 14.49

Current at resonance is minimum, hence such a circuit (when used in radio work) is sometimes known as **rejector** circuit because it rejects (or takes minimum current of) that frequency to which it resonates. This resonance is often referred to as current resonance also because the current circulating **between** the two branches is many times greater than the line current taken from the supply.

The phenomenon of parallel resonance is of great practical importance because it forms the basis of tuned circuits in Electronics.

The variations of impedance and current with frequency are shown in Fig. 14.49. As seen, at resonant frequency, impedance is maximum and equals  $L/CR$ . Consequently, current at resonance is minimum and is  $= V / (L/CR)$ . At off-resonance frequencies, impedance decreases and, as a result, current increases as shown.

### Alternative Treatment

$$Y_1 = \frac{1}{R + jX_L} = \frac{R}{R^2 + X_L^2} - j \frac{X_L}{R^2 + X_L^2}; \quad Y_2 = \frac{1}{-jX_C} = \frac{j}{X_C}$$

$$Y = \frac{R}{R^2 + X_L^2} + j \left( \frac{1}{X_C} - \frac{X_L}{R^2 + X_L^2} \right)$$

Now, circuit would be in resonance when  $j$ -component of the complex admittance is zero *i.e.*

$$\text{when } \frac{1}{X_C} - \frac{X_L}{R^2 + X_L^2} = 0 \text{ or } \frac{X_L}{R^2 + X_L^2} = \frac{1}{X_C}$$

$$\text{or } X_L X_C = R^2 + X_L^2 = Z^2$$

—as before

Talking in terms of susceptance, the above relations can be put as under :

$$\text{Inductive susceptance } B_L = \frac{X_L}{R^2 + X_L^2}; \text{ capacitive susceptance } B_C = \frac{1}{X_C}$$

$$\text{Net susceptance } B = (B_C - B_L) \quad \therefore Y = G + j(B_C - B_L) = G + jB.$$

The parallel circuit is said to be in resonance when  $B = 0$ .

$$\therefore B_C - B_L = 0 \text{ or } \frac{1}{X_C} = \frac{X_L}{R^2 + X_L^2}$$

The rest procedure is the same as above. It may be noted that at resonance, the admittance equals the conductance.

### 14.10. Graphic Representation of Parallel Resonance

We will now discuss the effect of variation of frequency on the susceptance of the two parallel branches. The variations are shown in Fig. 14.50.

#### (i) Inductive susceptance ;

$$b = -1/X_L = -1/2\pi f L$$

It is inversely proportional to the frequency of the applied voltage. Hence, it is represented by a rectangular hyperbola drawn in the fourth quadrant ( $\therefore$  it is assumed negative).

#### (ii) Capacitive susceptance ;

$$b = 1/X_C = \omega C = 2\pi f C$$

It increases with increase in the frequency of the applied voltage. Hence, it is represented by a straight line drawn in the first quadrant (it is assumed positive).

#### (iii) Net Susceptance B

It is the difference of the two susceptances and is represented by the dotted hyperbola. At point A, net susceptance is zero, hence admittance is minimum (and equal to  $G$ ). So at point A, line current is minimum.

Obviously, below resonant frequency (corresponding to point A), inductive susceptance predominates, hence line current lags behind the applied voltage. But for frequencies above the resonant frequency, capacitive susceptance predominates, hence line current leads.

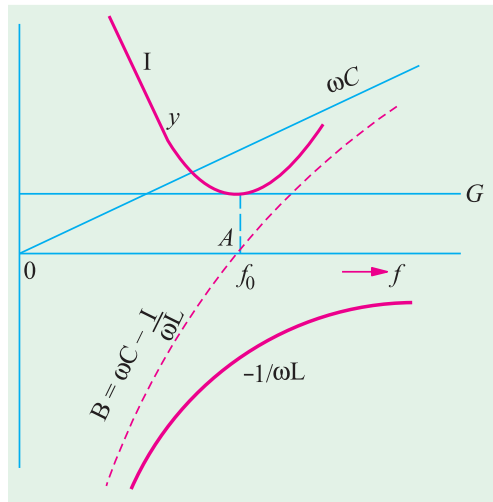

Fig. 14.50

### 14.11. Points to Remember

Following points about parallel resonance should be noted and compared with those about series resonance. At resonance.

1. net susceptance is zero *i.e.*  $1/X_C = X_L/Z^2$  or  $X_L \times X_C = Z^2$  or  $L/C = Z^2$
2. the admittance equals conductance
3. reactive or wattless component of line current is zero.
4. dynamic impedance =  $L/CR$  ohm.

5. line current at resonance is minimum and  $= \frac{V}{L/CR}$  but is in phase with the applied voltage.
6. power factor of the circuit is unity.

### 14.12. Bandwidth of a Parallel Resonant Circuit

The bandwidth of a parallel circuit is defined in the same way as that for a series circuit. This circuit also has upper and lower half-power frequencies where power dissipated is half of that at resonant frequency.

At bandwidth frequencies, the net susceptance  $B$  equals the conductance. Hence, at  $f_2$ ,  $B = B_{C2} - B_{L2} = G$ . At  $f_1$ ,  $B = B_{L1} - B_{C1} = G$ . Hence,  $Y = \sqrt{G^2 + B^2} = \sqrt{2}G$  and  $\phi = \tan^{-1}(B/G) = \tan^{-1}(1) = 45^\circ$ .

However, at off-resonance frequencies,  $Y > G$  and  $B_C \neq B_L$  and the phase angle is greater than zero.

#### Comparison of Series and Parallel Resonant Circuits

item	series circuit (R-L-C)	parallel circuit (R-L and C)
Impedance at resonance	Minimum	Maximum
Current at resonance	Maximum = $V/R$	Minimum = $V/(L/CR)$
Effective impedance	$R$	$L/CR$
Power factor at resonance	Unity	Unity
Resonant frequency	$1/2\pi\sqrt{LC}$	$\frac{1}{2\pi}\sqrt{\left(\frac{1}{LC} - \frac{R^2}{L^2}\right)}$
It magnifies	Voltage	Current
Magnification is	$\omega L/R$	$\omega L/R$

### 14.13. Q-factor of a Parallel Circuit

It is defined as *the ratio of the current circulating between its two branches to the line current drawn from the supply or simply, as the current magnification*. As seen from Fig. 14.51, the circulating current between capacitor and coil branches is  $I_C$ .

Hence  $Q$ -factor =  $I_C/I$

Now  $I_C = V/X_C = V/(1/\omega C) = \omega CV$

and  $I_C = V/(L/CR)$

$$\therefore Q \text{ -factor} = CV \frac{V}{L/CR} \frac{L}{R} \frac{2 f_0 L}{R}$$

$$= \tan \phi \text{ (same as for series circuit)}$$

where  $\phi$  is the power factor angle of the coil.

Now, resonant frequency when  $R$  is negligible is,

$$f_0 = \frac{1}{2\pi\sqrt{LC}}$$

Putting this value above, we get,  $Q$ -factor =  $\frac{2 f_0 L}{R} \frac{1}{2\sqrt{LC}} \frac{1}{R} \sqrt{L}$

It should be noted that in series circuits,  $Q$ -factor gives the voltage magnification, whereas in parallel circuits, it gives the current magnification.

Again,  $Q = 2\pi \frac{\text{maximum stored energy}}{\text{energy dissipated/cycle}}$

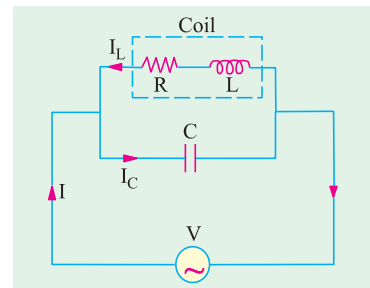

Fig. 14.51

**Example 14.45.** A capacitor is connected in parallel with a coil having  $L = 5.52 \text{ mH}$  and  $R = 10 \Omega$  to a 100-V, 50-Hz supply. Calculate the value of the capacitance for which the current taken from the supply is in phase with voltage. (Elect. Machines, A.M.I.E. Sec B, 1992)

**Solution.** At resonance,  $L/C = Z^2$  or  $C = L/Z^2$   
 $X_L = 2\pi \times 50 \times 5.52 \times 10^{-3} = 1.734 \Omega$ ,  $Z^2 = 10^2 + 1.734^2$ ,  $Z = 10.1 \Omega$   
 $C = 5.52 \times 10^{-3}/10.1 = 54.6 \mu\text{F}$

**Example 14.46.** Calculate the impedance of the parallel-tuned circuit as shown in Fig. 14.52 at a frequency of 500 kHz and for bandwidth of operation equal to 20 kHz. The resistance of the coil is  $5 \Omega$   
**(Circuit and Field Theory, A.M.I.E. Sec. B, 1993)**

**Solution.** At resonance, circuit impedance is  $L/CR$ . We have been given the value of  $R$  but that of  $L$  and  $C$  has to be found from the given data.

$$BW = \frac{R}{2L}, 20 \times 10^3 = \frac{5}{2L} \quad \text{or} \quad L = 39 \mu\text{H}$$

$$f_0 = \frac{1}{2\pi} \sqrt{\frac{1}{LC} - \frac{R^2}{L^2}} = \frac{1}{2\pi} \sqrt{\frac{1}{39 \times 10^{-6} C} - \frac{5^2}{(39 \times 10^{-6})^2}}$$

$$\therefore C = 2.6 \times 10^{-9} \text{ F}, Z = L/CR = 39 \times 10^{-6}/2.6 \times 10^{-9} \times 5 = 3 \times 10^3 \Omega$$

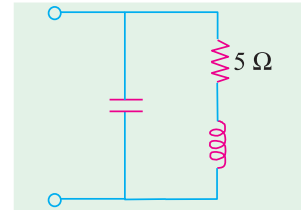

Fig. 14.52

**Example 14.47.** An inductive circuit of resistance 2 ohm and inductance 0.01 H is connected to a 250-V, 50-Hz supply. What capacitance placed in parallel will produce resonance?  
 Find the total current taken from the supply and the current in the branch circuits.  
**(Elect. Engineering, Kerala Univ.)**

**Solution.** As seen from Art. 14.9, at resonance  $C = L/Z^2$

$$\text{Now, } R = 2 \Omega, X_L = 314 \times 0.01 = 3.14 \Omega; Z = \sqrt{2^2 + 3.14^2} = 3.74 \Omega$$

$$C = 0.01/3.74^2 = 714 \times 10^{-6} \text{ F} = 714 \mu\text{F}; I_{RL} = 250/3.74 = 66.83 \text{ A}$$

$$\tan \phi_L = 3.14/2 = 1.57; \phi_L = \tan^{-1}(1.57) = 57.5^\circ$$

Hence, current in  $R$ - $L$  branch lags the applied voltage by  $57.5^\circ$

$$\therefore I_C = \frac{V}{X_C} = \frac{V}{1/\omega C} = \omega VC = 250 \times 314 \times 714 \times 10^{-6} = 56.1 \text{ A}$$

This current leads the applied voltage by  $90^\circ$ .

Total current taken from the supply under resonant condition is

$$I = I_{RL} \cos \phi_L = 66.83 \cos 57.5^\circ = 66.83 \times 0.5373 = 35.9 \text{ A} \quad \left(\text{or } I = \frac{V}{L/CR}\right)$$

**Example 14.48.** Find active and reactive components of the current taken by a series circuit consisting of a coil of inductance 0.1 henry and resistance  $8 \Omega$  and a capacitor of  $120 \mu\text{F}$  connected to a 240-V, 50-Hz supply mains. Find the value of the capacitor that has to be connected in parallel with the above series circuit so that the p.f. of the entire circuit is unity.  
**(Elect. Technology, Mysore Univ.)**

**Solution.**  $X_L = 2\pi \times 50 \times 0.1 = 31.4 \Omega$ ,  $X_C = 1/\omega C = 1/2\pi \times 50 \times 120 \times 10^{-6} = 26.5 \Omega$

$$X = X_L - X_C = 31.4 - 26.5 = 5 \Omega, Z = \sqrt{8^2 + 5^2} = 9.43 \Omega; I = V/Z = 240/9.43 = 25.45 \text{ A}$$

$$\cos \phi = R/Z = 8/9.43 = 0.848, \sin \phi = X/Z = 5/9.43 = 0.53$$

$$\text{active component of current} = I \cos \phi = 25.45 \times 0.848 = 21.58 \text{ A}$$

$$\text{reactive component of current} = I \sin \phi = 25.45 \times 0.53 = 13.49 \text{ A}$$

Let a capacitor of capacitance  $C$  be joined in parallel across the circuit.

$$Z_1 = R + jX = 8 + j5; Z_2 = -jX_C;$$

$$Y = Y_1 + Y_2 = \frac{1}{Z_1} + \frac{1}{Z_2} = \frac{1}{8 + j5} + \frac{1}{-jX_C}$$

$$= \frac{8 - j5}{89} + \frac{j}{X_C} = 0.0899 - j0.056 + \frac{j}{X_C} = 0.0899 + j(1/X_C - 0.056)$$

For p.f. to be unit, the  $j$ -component of  $\mathbf{Y}$  must be zero.

$$\therefore \frac{1}{X_C} - 0.056 = 0 \text{ or } 1/X_C = 0.056 \text{ or } \omega C = 0.056 \text{ or } 2\pi \times 50C = 0.056$$

$$\therefore C = 0.056/100\pi = 180 \times 10^{-6} \text{ F} = \mathbf{180 \mu F}$$

**Example 14.49.** A coil of resistance  $20 \Omega$  and inductance  $200 \mu\text{H}$  is in parallel with a variable capacitor. This combination is in series with a resistor of  $8000 \Omega$ . The voltage of the supply is  $200 \text{ V}$  at a frequency of  $10^6 \text{ Hz}$ . Calculate

- (i) the value of  $C$  to give resonance
- (ii) the  $Q$  of the coil
- (iii) the current in each branch of the circuit at resonance.

(Similar Question : Bombay Univ. 2000)

**Solution.** The circuit is shown in Fig. 14.53.

$$X_L = 2\pi fL = 2\pi \times 10^6 \times 200 \times 10^{-6} = 1256 \Omega$$

Since coil resistance is negligible as compared to its reactance, the resonant frequency is given by

$$f = \frac{1}{2\pi\sqrt{LC}}$$

$$\therefore 10^6 = \frac{1}{2\pi\sqrt{200 \times 10^{-6} \times C}}$$

$$(i) \therefore C = \mathbf{125 \mu F}$$

$$(ii) Q = \frac{2\pi fL}{R} = \frac{2\pi \times 10^6 \times 200 \times 10^{-4}}{20} = \mathbf{62.8}$$

$$(iii) \text{ Dynamic resistance of the circuit is } = \frac{L}{CR} = \frac{200 \times 10^{-6}}{125 \times 10^{-12} \times 20} = 80,000 \Omega$$

Total equivalent resistance of the tuned circuit is  $80,000 + 8,000 = 88,000 \Omega$

$$\therefore \text{Current } I = 200/88,000 = 2.27 \text{ mA}$$

p.d. across tuned circuit = current  $\times$  dynamic resistance =  $2.27 \times 10^{-3} \times 80,000 = 181.6 \text{ V}$

$$\text{Current through inductive branch} = \frac{181.6}{\sqrt{10^2 + 1256^2}} = 0.1445 \text{ A} = \mathbf{144.5 \text{ mA}}$$

Current through capacitor branch

$$= \frac{V}{1/\omega C} = \omega VC = 181.6 \times 2\pi \times 10^6 \times 125 \times 10^{-12} = \mathbf{142.7 \text{ mA}}$$

**Note.** It may be noted in passing that current in each branch is nearly 62.8 (i.e.  $Q$ -factor) times the resultant current taken from the supply.

**Example 14.50.** Impedances  $Z_2$  and  $Z_3$  in parallel are in series with an impedance  $Z_1$  across a  $100\text{-V}$ ,  $50\text{-Hz}$  a.c. supply.  $Z_1 = (6.25 + j 1.25) \text{ ohm}$ ;  $Z_2 = (5 + j0) \text{ ohm}$  and  $Z_3 = (5 - j X_C) \text{ ohm}$ . Determine the value of capacitance of  $X_C$  such that the total current of the circuit will be in phase with the total voltage. When is then the circuit current and power?

(Elect. Engg-I, Nagpur Univ, 1992)

$$\text{Solution. } Z_{23} = \frac{5(5 - jX_C)}{(10 - jX_C)}, \text{ for the circuit in}$$

Fig. 14.59.

$$= \frac{25 - j5X_C}{(10 - jX_C)} \times \frac{10 + jX_C}{10 + jX_C} = \frac{250 + 5X_C^2}{100 + X_C^2} - j \frac{25X_C}{100 + X_C^2}$$

$$\mathbf{Z} = 6.25 + j 1.25 + \frac{250 + 5X_C^2}{100 + X_C^2} - j \frac{25X_C}{100 + X_C^2}$$

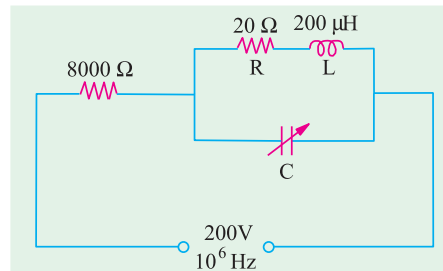

Fig. 14.53

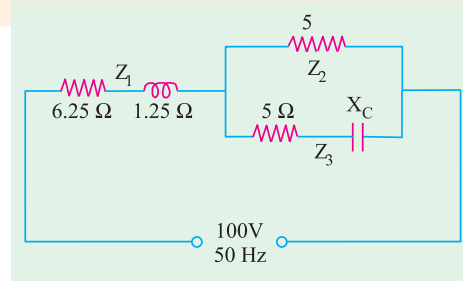

Fig. 14.54

$$= 6.25 \frac{250}{100} \frac{5X_C^2}{X_C^2} - j \frac{25X_C}{100} \frac{5}{X_C^2}$$

Power factor will be unity or circuit current will be in phase with circuit voltage if the  $j$  term in the above equation is zero.

$$\therefore \left( \frac{25X_C}{100 + X_C^2} - \frac{5}{4} \right) = 0 \text{ or } X_C = 10 \quad \therefore 1/\omega C = 10 \text{ or } C = 1/314 \times 10 = \mathbf{318 \mu F}$$

Substituting the value of  $X_C = 10 \Omega$  above, we get

$$Z = 10 - j0 = 10 \angle 0^\circ \text{ and } I = 100/10 = \mathbf{10 A}; \text{ Power} = I^2 R = 10^2 \times 10 = \mathbf{1000 W}$$

**Example 14.51.** In the circuit given below, if the value of  $R = \sqrt{L/C}$ , then prove that the impedance of the entire circuit is equal to  $R$  only and is independent of the frequency of supply. Find the value of impedance for  $L = 0.02 \text{ H}$  and  $C = 100 \mu\text{F}$ .

(Communication System, Hyderabad Univ. 1991)

**Solution.** The impedance of the circuit of Fig. 14.55 is

$$Z = \frac{(R + j\omega L)(R - j/\omega C)}{2R + j(\omega L - 1/\omega C)} = \frac{R^2 + (L/C) + jR(\omega L - 1/\omega C)}{2R + j(\omega L - 1/\omega C)}$$

If  $R^2 = L/C$  or  $R = \sqrt{L/C}$ , then

$$Z = \frac{R^2 + R^2 + jR(\omega L - 1/\omega C)}{2R + j(\omega L - 1/\omega C)}$$

$$= R \left[ \frac{2R + j(\omega L - 1/\omega C)}{2R + j(\omega L - 1/\omega C)} \right] \text{ or } \mathbf{Z = R}$$

$$\text{Now, } R = \sqrt{\frac{L}{C}} = \sqrt{\frac{0.02}{100 \times 10^{-6}}} = \mathbf{14.14 \Omega}$$

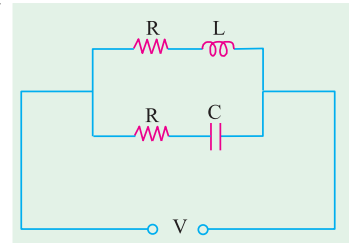

Fig. 14.55

**Example 14.52.** Derive an expression for the resonant frequency of the parallel circuit shown in Fig. 14.46.

(Electrical Circuit, Nagpur Univ, 1993)

**Solution.** As stated in Art. 14.9 for resonance of a parallel circuit, total circuit susceptance should be zero. Susceptance of the  $R$ - $L$  branch is

$$B_1 = -\frac{X_L}{R_1^2 + X_L^2}$$

Similarly, susceptance of the  $R$ - $C$  branch is

$$B_2 = \frac{X_C}{R_2^2 + X_C^2}$$

Net susceptance is  $B = -B_1 + B_2$

For resonance  $B = 0$  or  $0 = -B_1 + B_2 \therefore B_1 = B_2$

$$\text{or } \frac{X_L}{R_1^2 + X_L^2} = \frac{X_C}{R_2^2 + X_C^2} \text{ or } X_L(R_2^2 + X_C^2) = X_C(R_1^2 + X_L^2)$$

$$2fL R_2^2 - \frac{1}{2fC} = \frac{1}{2fC} [R_1^2 - (2fL)^2]; 4^2 f^2 LC R_2^2 - \frac{1}{2fC} = \frac{1}{2fC} [R_1^2 - (2fL)^2]$$

$$\therefore 4\pi^2 f^2 LCR_2^2 + \frac{L}{C} = R_1^2 + 4\pi^2 f^2 L^2; 4\pi^2 f^2 [L(L - CR_2^2)] = \frac{L}{C} - R_1^2$$

$$\therefore f_0 = \frac{1}{2\pi} \sqrt{\left( \frac{L/C - R_1^2}{L(L - CR_2^2)} \right)} \quad \therefore f_0 = \frac{1}{2\pi} \sqrt{\left( \frac{L - CR_1^2}{LC(L - CR_2^2)} \right)}; \omega_0 = \frac{1}{\sqrt{LC}} \sqrt{\left( \frac{L - CR_1^2}{L - CR_2^2} \right)}$$

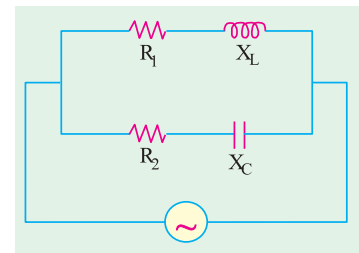

Fig. 14.56

**Note.** If both  $R_1$  and  $R_2$  are negligible, then  $f_0 = \frac{1}{2\pi\sqrt{LC}}$  —as in Art. 14.9

**Example 14.53.** Calculate the resonant frequency of the network shown in Fig. 14.57.

**Solution.** Total impedance of the network between terminals A and B is

$$\begin{aligned} Z_{AB} &= (R_1 \parallel jX_L) + [R_2 \parallel (-jX_C)] = \frac{jR_1X_L}{R_1 + jX_L} + \frac{R_2(-jX_C)}{R_2 - jX_C} = \frac{jR_1\omega L}{R_1 + j\omega L} - \frac{jR_2/\omega C}{R_2 - j/\omega C} \\ &= \frac{R_1\omega^2 L^2}{R_1^2 + \omega^2 L^2} + \frac{R_2}{\omega C(R_2^2 + 1/\omega^2 C^2)} + j \left[ \frac{R_1^2\omega L}{R_1^2 + \omega^2 L^2} - \frac{R_2^2}{\omega C(R_2^2 + 1/\omega^2 C^2)} \right] \end{aligned}$$

At resonance,  $\omega = \omega_0$  and the  $j$  term of  $Z_{AB}$  is zero.

$$\therefore \frac{R_1^2\omega_0 L}{R_1^2 + \omega_0^2 L^2} - \frac{R_2^2}{\omega_0 C(R_2^2 + 1/\omega_0^2 C^2)} = 0$$

$$\text{or } \frac{R_1^2\omega_0 L}{R_1^2 + \omega_0^2 L^2} = \frac{R_2^2\omega_0 C}{R_2^2\omega_0^2 C^2 + 1}$$

Simplifying the above, we get

$$\omega_0^2 = \frac{G_2^2 - C/L}{LC(G_1^2 - C/L)} \text{ where } G_1 = \frac{1}{R_1} \text{ and } G_2 = \frac{1}{R_2}$$

The resonant frequency of the given network in Hz is

$$f_0 = \frac{0}{2} \frac{1}{2} \sqrt{\frac{G_2^2 C/L}{LC(G_1^2 - C/L)}}$$

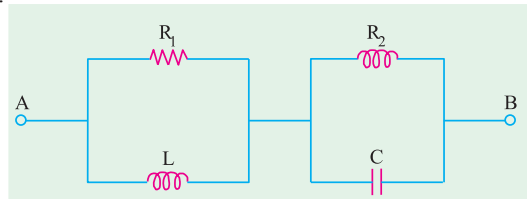

Fig. 14.57

**Example 14.54.** Compute the value of  $C$  which results in resonance for the circuit shown in Fig. 14.58 when  $f = 2500/\pi$  Hz.

**Solution.**  $Y_1 = 1/(6 + j8)$

$Y_2 = 1/(4 - jX_C)$

$$\begin{aligned} Y &= Y_1 + Y_2 = \frac{1}{6 + j8} + \frac{1}{4 - jX_C} \\ &= \left( 0.06 + \frac{4}{16 + X_C^2} \right) + j \left( \frac{X_C}{16 + X_C^2} - 0.08 \right) \end{aligned}$$

For resonance,  $j$  part of admittance is zero, i.e. the complex admittance is real number.

$$\therefore X_C / (16 + X_C^2) - 0.08 = 0 \text{ or } 0.08 X_C^2 - X_C + 1.28 = 0$$

$$\therefore X_C = 11.05 \text{ or } 1.45 \therefore 1/\omega C = 11.05 \text{ or } 1.45$$

(i)  $1/5000C = 11.05$  or  $C = 18 \mu\text{F}$  (ii)  $1/5000 C = 1.45$  or  $C = 138 \mu\text{F}$

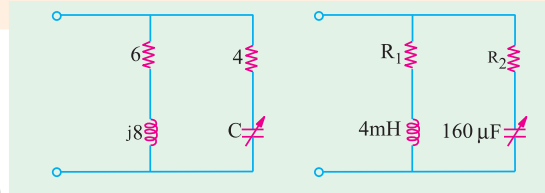

Fig. 14.58

Fig. 14.59

**Example 14.55.** Find the values of  $R_1$  and  $R_2$  which will make the circuit of Fig. 14.59 resonate at all frequencies.

**Solution.** As seen from Example 14.42, the resonant frequency of the given circuit is

$$\omega_0 = \frac{1}{\sqrt{LC}} \sqrt{\left( \frac{L - CR_1^2}{L - CR_2^2} \right)}$$

Now,  $\omega_0$  can assume any value provided  $R_1^2 = R_2^2 = L/C$ .

In the present case,  $L/C = 4 \times 10^{-3}/60 \times 10^{-6} = 25$ . Hence,  $R_1 = R_2 = \sqrt{25} = 5 \text{ ohm}$ .

## Tutorial Problem No. 14.2

- A resistance of 20  $\Omega$  and a coil of inductance 31.8 mH and negligible resistance are connected in parallel across 230 V, 50 Hz supply. Find (i) The line current (ii) power factor and (iii) The power consumed by the circuit. **[(i) 25.73 A (ii) 0.44 T lag (iii) 246 W] (F. E. Pune Univ.)**
- Two impedances  $Z_1 = (150 + j157) \Omega$  and  $Z_2 = (100 + j110) \Omega$  are connected in parallel across a 220-V, 50-Hz supply. Find the total current and its power factor. **[24  $\angle$ - 47°A ; 0.68 (lag)] (Elect. Engg. & Electronics Bangalore Univ.)**
- Two impedances  $(14 + j5) \Omega$  and  $(18 + j10) \Omega$  are connected in parallel across a 200-V, 50-Hz supply. Determine (a) the admittance of each branch and of the entire circuit ; (b) the total current, power, and power factor and (c) the capacitance which when connected in parallel with the original circuit will make the resultant power factor unity. **[(a) (0.0634 -j0.0226), (0.0424 -j0.023) (0.1058 -j0.0462 S) (b) 23.1 A, 4.232 kW, 0.915 (c) 147  $\mu$ F]**
- A parallel circuit consists of two branches A and B. Branch A has a resistance of 10  $\Omega$  and an inductance of 0.1 H in series. Branch B has a resistance of 20  $\Omega$  and a capacitance of 100  $\mu$ F in series. The circuit is connected to a single-phase supply of 250 V, 50 Hz. Calculate the magnitude and the phase angle of the current taken from the supply. Verify your answer by measurement from a phasor diagram drawn to scale. **[6.05  $\angle$ - 15.2°] (F. E. Pune Univ.)**
- Two circuits, the impedances of which are given by  $Z_1 = (10 + j15) \Omega$  and  $Z_2 = (6 - j8) \Omega$  are connected in parallel. If the total current supplied is 15 A, what is the power taken by each branch ? **[737 W ; 1430 W] (Elect. Engg. A.M.A.E. S.I.)**
- A voltage of 240 V is applied to a pure resistor, a pure capacitor, and an inductor in parallel. The resultant current is 2.3 A, while the component currents are 1.5, 2.0 and 1.1 A respectively. Find the resultant power factor and the power factor of the inductor. **[0.88 ; 0.5]**
- Two parallel circuits comprise respectively (i) a coil of resistance 20  $\Omega$  and inductance 0.07 H and (ii) a capacitance of 60  $\mu$ F in series with a resistance of 50  $\Omega$ . Calculate the current in the mains and the power factor of the arrangement when connected across a 200-V, 50-Hz supply. **[7.05 A ; 0.907 lag] (Elect. Engg. & Electronics, Bangalore Univ.)**
- Two circuits having the same numerical ohmic impedances are joined in parallel. The power factor of one circuit is 0.8 lag and that of other 0.6 lag. Find the power factor of the whole circuit. **[0.707] (Elect. Engg. Pune Univ.)**
- How is a current of 10 A shared by three circuits in parallel, the impedances of which are  $(2 - j5) \Omega$ ,  $(6 + j3) \Omega$  and  $(3 + j4) \Omega$ . **[5.68 A ; 4.57 A, 6.12 A]**
- A piece of equipment consumes 2,000 W when supplied with 110 V and takes a lagging current of 25 A. Determine the equivalent series resistance and reactance of the equipment. If a capacitor is connected in parallel with the equipment to make the power factor unity, find its capacitance. The supply frequency is 100 Hz. **[3.2  $\Omega$ , 3.02  $\Omega$ , 248  $\mu$ F] (Sheffield Univ. U.K.)**
- A capacitor is placed in parallel with two inductive loads, one of 20 A at 30° lag and one of 40° A at 60° lag. What must be current in the capacitor so that the current from the external circuit shall be at unity power factor ? **[44.5 A] (City & Guilds, London)**
- An air-cored choking coil is subjected to an alternating voltage of 100 V. The current taken is 0.1 A and the power factor 0.2 when the frequency is 50 Hz. Find the capacitance which, if placed in parallel with the coil, will cause the main current to be a minimum. What will be the impedance of this parallel combination (a) for currents of frequency 50 (b) for currents of frequency 40 ? **[3.14  $\mu$ F (a) 5000  $\Omega$  (b) 1940  $\Omega$ ] (London Univ.)**
- A circuit, consisting of a capacitor in series with a resistance of 10  $\Omega$ , is connected in parallel with a coil having  $L = 55.2$  mH and  $R = 10 \Omega$ , to a 100-V, 50-Hz supply. Calculate the value of the capacitance for which the current take from the supply is in phase with the voltage. Show that for the particular values given, the supply current is independent of the frequency. **[153  $\mu$ F] (London Univ.)**
- In a series-parallel circuit, the two parallel branches A and B are in series with C. The impedances are  $Z_A = (10 - j8) \Omega$ ,  $Z_B = (9 - j6) \Omega$  and  $Z_C = (100 + j0)$ . Find the currents  $I_A$  and  $I_B$  and the phase difference between them. Draw the phasor diagram. **[ $I_A = 12.71 \angle 30^\circ 58'$  ;  $I_B = 15 \angle 35^\circ 56'$  ;  $4^\circ 58'$ ] (Elect. Engg. & Electronics Bangalore Univ.)**
- Find the equivalent series circuits of the 4-branch parallel circuit shown in Fig. 14.60. **[(4.41 + j2.87)  $\Omega$ ] [A resistor of 4.415  $\Omega$  in series with a 4.57 mH inductor]**

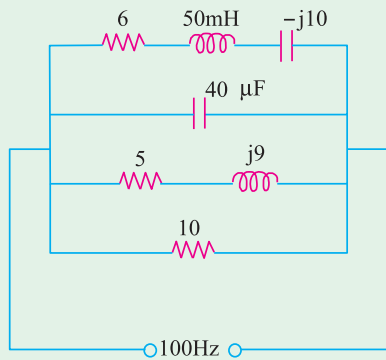

Fig. 14.60

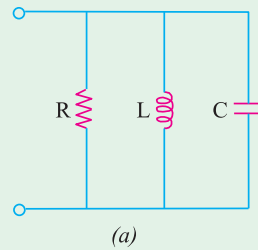
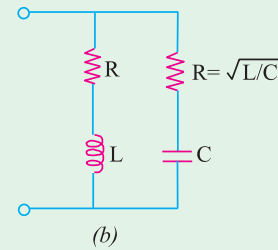

Fig. 14.61



16. A coil of 20 Ω resistance has an inductance of 0.2 H and is connected in parallel with a 100-μF capacitor. Calculate the frequency at which the circuit will act as a non-inductive resistance of R ohms. Find also the value of R. [31.8 Hz; 100 Ω]
17. Calculate the resonant frequency, the impedance at resonance and the Q-factor at resonance for the two circuits shown in Fig. 14.61.

(a)  $f_0 = \frac{1}{2\pi\sqrt{LC}}$  ;  $Z_0 = R$  ;  $Q_0 = \frac{R}{\sqrt{L/C}}$

(b) Circuit is resonant at all frequencies with a constant resistive impedance of  $(\sqrt{L/C})$  ohm,  $Q = 0$ .

18. Prove that the circuit shown in Fig. 14.62 exhibits both series and parallel resonances and calculate the frequencies at which two resonances occur.

Parallel  $f_0 = \frac{1}{2\pi} \sqrt{\frac{1}{(L_2 C_2)}}$  ; series  $f_0 = \frac{1}{2\pi} \sqrt{\frac{(L_1 + L_2)}{L_1 L_2 C_2}}$

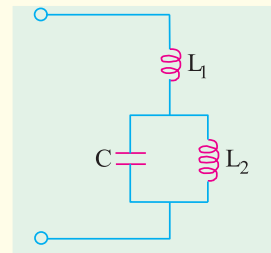

Fig. 14.62

19. Calculate the resonant frequency and the corresponding Q-factor for each of the networks shown in Fig. 14.63.

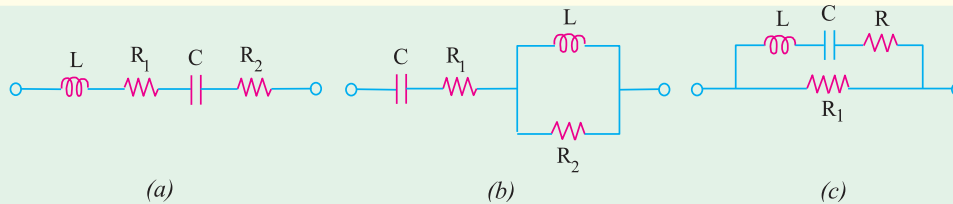

Fig. 14.63

(a)  $f_0 = \frac{1}{2\pi\sqrt{LC}}$  ;  $Q = \frac{\omega_0 L}{R_1 + R_2} = \frac{1}{\omega_0 C(R_1 + R_2)} = \frac{1}{(R_1 + R_2)} \cdot \sqrt{\frac{L}{C}}$

(b)  $f_0 = \frac{1}{2} \sqrt{\frac{1}{LC} \frac{1}{L^2/R_2^2}}$  ;  $Q = \frac{R_2}{\omega_0(L + R_1 R_2 C)}$  (c)  $f_0 = \frac{1}{2\pi\sqrt{LC}}$  ;  $Q = \frac{\omega_0 L}{R} \times \frac{R_1}{R + R_1} = \frac{R_1}{R(R + R_1)} \cdot \sqrt{\frac{L}{C}}$

20. A parallel R-L-C circuit is fed by a constant current source of variable frequency. The circuit resonates at 100 kHz and the Q-factor measured at this frequency is 5. Find the frequencies at which the amplitude of the voltage across the circuit falls to (a) 70.7% (b) 50% of the resonant frequency amplitude. [(a) 90.5 kHz ; 110.5 kHz (b) 84.18 kHz ; 118.8 kHz]

21. Two impedance  $Z_1 = (6 + j8)$  ohm and  $Z_2 = (8 - j6)$  ohm are connected in parallel across 100 V supply. Determine : (i) Current and power factor of each branch. (ii) Overall current and power factor (iii) Power consumed by each branch and total power. (Nagpur University, Winter 2003)

22. The currents in each branch of a two branched parallel circuit is given as :

$$i_a = 8.07 \sin \left( 314 t - \frac{\pi}{4} \right)$$

$$i_b = 21.2 \sin \left( 314 t - \frac{\pi}{3} \right)$$

and supply voltage is  $v = 354 \sin 314 t$ .

Calculate :

- (i) Total current in the same form (ii) Calculate ohmic value of components in each branch.

(Nagpur University, Summer 2004)

23. Two coils are connected in parallel and a voltage of 200 V is applied between the terminals the total current taken by the circuit is 25 A and power dissipated in one of the coils is 1500 W. Calculate the resistance of each coil.

(Gujrat University, June/July 2003)

24. Compare the series and parallel resonance of R-L-C series and R-L-C parallel circuit.

(Gujrat University, June/July 2003)

25. Two circuits with impedances  $Z_1 = (10 + j15) \Omega$  and  $z_2 = (6 - j8) \Omega$  are connected in parallel. If the supply current is 20A, what is the power dissipated in each branch.

(V.T.U., Belgaum Karnataka University, Winter 2003)

26. Three impedances  $z_1 = 8 + j6 \Omega$ ,  $z_2 = 2 - j1.5 \Omega$  and  $z_3 = 2 \Omega$  are connected in parallel across a 50Hz supply. If the current through  $z_1$  is  $3 + j4$  amp, calculate the current through the other impedances and also power absorbed by this parallel circuit.

(V.T.U. Belgaum Karnataka University, Winter 2004)

27. Show that the power consumed in a pure inductance is zero.

(RGPV Bhopal 2002)

28. What do you understand by the terms power factor, active power and reactive power?

(RGPV Bhopal 2002)

29. Two circuits the impedances of which are given by  $Z_1 = (10 + j15) \Omega$  and  $Z_2 = (6 - j8) \Omega$  are connected in parallel. If the total current supplied is 15 A. What is the power taken by each branch?

(RGPV Bhopal 2002)

30. Does an inductance draw instantaneous power as well as average power?

(RGPV Bhopal December 2002)

31. Describe the properties of (i) Resistance (ii) Inductance and (iii) capacitance used in A.C. Circuit.

(RGPV Bhopal June 2003)

## OBJECTIVE TYPES – 14

1. Fill in the blanks

- (a) unit of admittance is .....  
 (b) unit of capacitive susceptance is .....  
 (c) admittance equals the reciprocal of .....  
 (d) admittance is given by the ..... sum of conductance and susceptance.

2. An R-L circuit has  $Z = (6 + j8) \Omega$ . Its susceptance is -Siemens.

- (a) 0.06 (b) 0.08 (c) 0.1 (d) -0.08

3. The impedances of two parallel branches of a circuit are  $(10 + j10)$  and  $(10 - j10)$  respectively. The impedance of the parallel combination is

- (a)  $20 + j0$  (b)  $10 + j0$   
 (c)  $5 - j5$  (d)  $0 - j20$

4. The value of Z in Fig. 14.64 which is most appropriate to cause parallel resonance at 500 Hz is

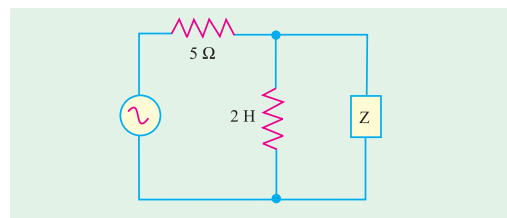

Fig. 14.64

- (a) 125.00 mH (b) 304.20  $\mu$ F  
 (c) 2.0  $\mu$ F (d) 0.05  $\mu$ F

(GATE 2004)