

CHAPTER 16

Learning Objectives

- A.C. Bridges
- Maxwell's Inductance Bridge
- Maxwell-Wien Bridge
- Anderson Bridge
- Hay's Bridge
- The Owen Bridge
- Heaviside Compbell Equal Ratio Bridge
- Capacitance Bridge
- De Sauty Bridge
- Schering Bridge
- Wien Series Bridge
- Wien Parallel Bridge

A.C. BRIDGES



A wide variety of AC bridge circuits (such as wheatstone) may be used for the precision measurement of AC resistance, capacitance and inductance

16.1. A.C. Bridges

Resistances can be measured by direct-current Wheatstone bridge, shown in Fig. 16.1 (a) for which the condition of balance is that

$$\frac{R_1}{R_2} = \frac{R_4}{R_3} \text{ or } R_1 R_3 = R_2 R_4^*$$

Inductances and capacitances can also be measured by a similar four-arm bridge, as shown in Fig. 16.1 (b); instead of using a source of direct current, alternating current is employed and galvanometer is replaced by a vibration galvanometer (for commercial frequencies or by telephone detector if frequencies are higher (500 to 2000 Hz)).

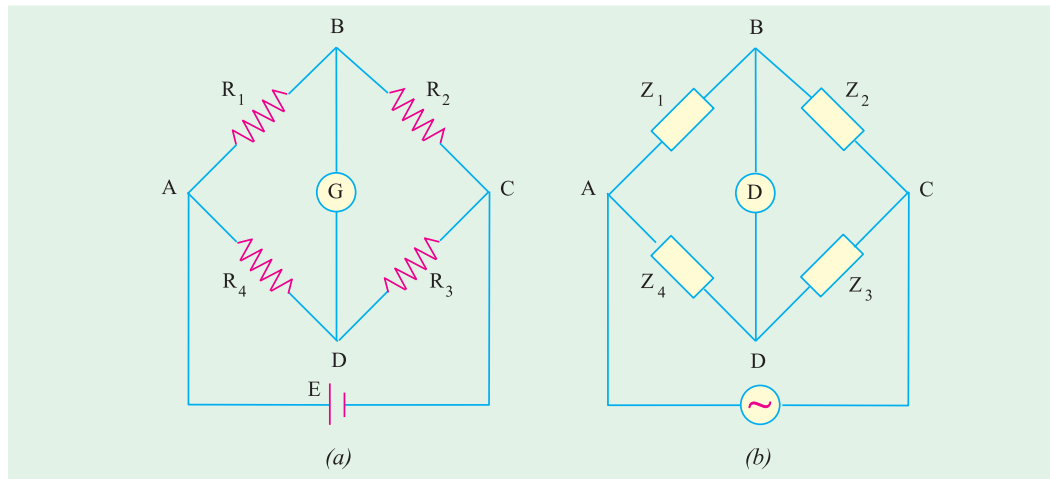

Fig. 16.1

The condition for balance is the same as before but instead of resistances, impedances are used *i.e.*

$$Z_1 / Z_2 = Z_4 / Z_3 \text{ or } Z_1 Z_3 = Z_2 Z_4$$

But there is one important difference *i.e.* not only should there be balance for the magnitudes of the impedances but also a phase balance. Writing the impedances in their polar form, the above condition becomes

$$Z_1 \angle \phi_1 \cdot Z_3 \angle \phi_3 = Z_2 \angle \phi_2 \cdot Z_4 \angle \phi_4 \text{ or } Z_1 Z_3 \angle \phi_1 + \phi_3 = Z_2 Z_4 \angle \phi_2 + \phi_4$$

Hence, we see that, in fact, there are two balance conditions which must be satisfied simultaneously in a four-arm a.c. impedance bridge.

$$(i) \quad Z_1 Z_3 = Z_2 Z_4 \quad \dots \text{ for magnitude balance}$$

$$(ii) \quad \phi_1 + \phi_3 = \phi_2 + \phi_4 \quad \dots \text{ for phase angle balance}$$

In this chapter, we will consider a few of the numerous bridge circuits used for the measurement of self-inductance, capacitance and mutual inductance, choosing as examples some bridges which are more common.

16.2. Maxwell's Inductance Bridge

The bridge circuit is used for medium inductances and can be arranged to yield results of considerable precision. As shown in Fig. 16.2, in the two arms, there are two pure resistances so

* Products of opposite arm resistances are equal.

that for balance relations, the phase balance depends on the remaining two arms. If a coil of an unknown impedance Z_1 is placed in one arm, then its positive phase angle ϕ_1 can be compensated for in either of the following two ways:

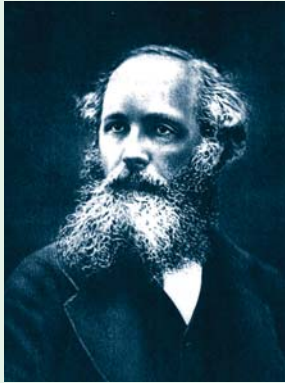

James Clark Maxwell

(i) A known impedance with an equal positive phase angle may be used in either of the *adjacent* arms (so that $\phi_1 = \phi_3$ or $\phi_2 = \phi_4$), remaining two arms have zero phase angles (being pure resistances). Such a network is known as Maxwell's a.c. bridge or L_1/L_4 bridge.

(ii) Or an impedance with an equal *negative* phase angle (i.e. capacitance) may be used in *opposite* arm (so that $\phi_1 + \phi_3 = 0$). Such a network is known as Maxwell-Wien bridge (Fig. 16.5) or Maxwell's L/C bridge.

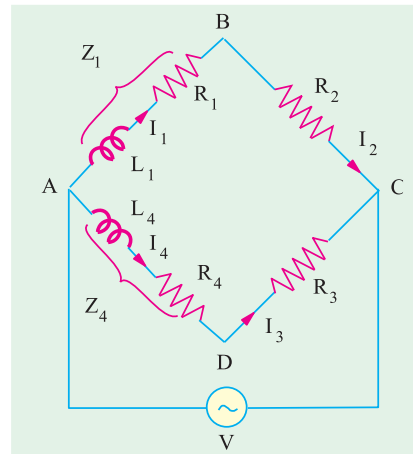

Fig. 16.2

Hence, we conclude that an inductive impedance may be measured in terms of another inductive impedance (of equal time constant) in either *adjacent* arm (Maxwell bridge) or the unknown inductive impedance may be measured in terms of a combination of resistance and capacitance (of equal time constant) in the *opposite* arm (Maxwell-Wien bridge). It is important, however, that in each case the time constants of the two impedances must be matched.

As shown in Fig. 16.2,

$$Z_1 = R_1 + jX_1 = R_1 + j\omega L_1 \dots \text{unknown}; Z_4 = R_4 + jX_4 = R_4 + j\omega L_4 \dots \text{known}$$

$R_2, R_3 =$ known pure resistances; $D =$ detector

The inductance L_4 is a variable self-inductance of constant resistance, its inductance being of the same order as L_1 . The bridge is balanced by varying L_4 and one of the resistances R_2 or R_3 .

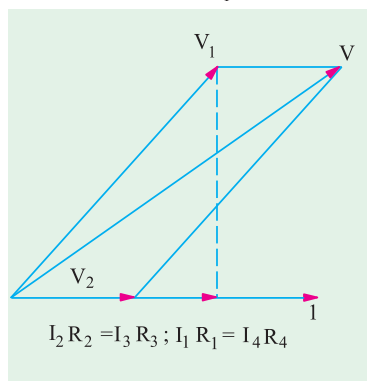

Fig. 16.3

$$I_2 R_2 = I_3 R_3; I_1 R_1 = I_4 R_4$$

Alternatively, R_2 and R_3 can be kept constant and the resistance of one of the other two arms can be varied by connecting an additional resistance in that arm (Ex. 16.1).

The balance condition is that $Z_1 Z_3 = Z_2 Z_4$

$$\therefore (R_1 + j\omega L_1)R_3 = (R_4 + j\omega L_4)R_2$$

Equating the real and imaginary parts on both sides, we have

$$R_1 R_3 = R_2 R_4 \text{ or } R_1 / R_4 = R_2 / R_3 *$$

(i.e. products of the resistances of opposite arms are equal).

$$\text{and } \omega L_1 R_3 = \omega L_4 R_2 \text{ or } L_1 = L_4 \frac{R_2}{R_3}$$

We can also write that $L_1 = L_4 \frac{R_1}{R_4}$

* Or $\frac{L_1}{R_1} = \frac{L_4}{R_4}$ i.e., the time constants of the two coils are matched.

Hence, the unknown self-inductance can be measured in terms of the known inductance L_4 and the two resistors. Resistive and reactive terms balance independently and the conditions are independent of frequency. This bridge is often used for measuring the iron losses of the transformers at audio frequency.

The balance condition is shown vectorially in Fig. 16.3. The currents I_4 and I_3 are in phase with I_1 and I_2 . This is, obviously, brought about by adjusting the impedances of different branches, so that these currents lag behind the applied voltage V by the same amount. At balance, the voltage drop V_1 across branch 1 is equal to that across branch 4 and $I_3 = I_4$. Similarly, voltage drop V_2 across branch 2 is equal to that across branch 3 and $I_1 = I_2$.

Example 16.1. The arms of an a.c. Maxwell bridge are arranged as follows: AB and BC are non-reactive resistors of $100\ \Omega$ each, DA is a standard variable reactor L_1 of resistance $32.7\ \Omega$ and CD comprises a standard variable resistor R in series with a coil of unknown impedance. Balance was obtained with $L_1 = 47.8\ \text{mH}$ and $R = 1.36\ \Omega$. Find the resistance and inductance of the coil.

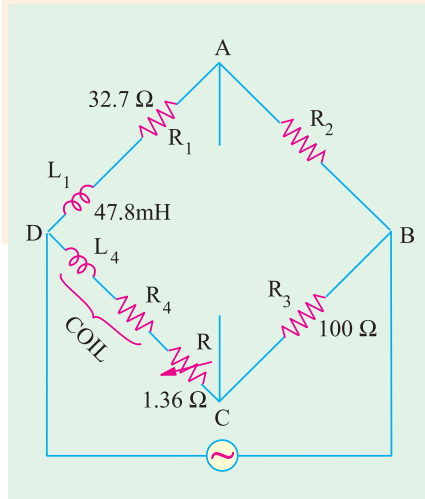

Fig. 16.4

(Elect. Inst. & Meas. Nagpur Univ. 1993)

Solution. The a.c. bridge is shown in Fig. 16.4.

Since the products of the resistances of opposite arms are equal

$$\therefore 32.7 \times 100 = (1.36 + R_4) 100$$

$$\therefore 32.7 = 1.36 + R_4 \text{ or } R_4 = 32.7 - 1.36 = \mathbf{31.34\ \Omega}$$

$$\text{Since } L_1 \times 100 = L_4 \times 100 \therefore L_4 = L_1 = \mathbf{47.8\ \text{mH}}$$

or because time constants are the same, hence

$$L_1/32.7 = L_4/(31.34 + 1.36) \therefore L_4 = 47.8\ \text{mH}$$

16.3. Maxwell-Wien Bridge or Maxwell's L/C Bridge

As referred to in Art. 16.2, the *positive* phase angle of an inductive impedance may be compensated by the *negative* phase angle of a capacitive impedance put in the *opposite* arm. The unknown inductance then becomes known in terms of this capacitance.

Let us first find the combined impedance of arm 1.

$$\frac{1}{Z_1} = \frac{1}{R_1} + \frac{1}{-jX_C} = \frac{1}{R_1} + \frac{j}{X_C} = \frac{1}{R_1} + j\omega C = \frac{1 + j\omega CR_1}{R_1}$$

$$\therefore Z_1 = \frac{R_1}{1 - j CR_1}; Z_2 = R_2$$

$$Z_3 = R_3 + j\omega L_3 \text{ and } Z_4 = R_4$$

Balance condition is $Z_1 Z_3 = Z_2 Z_4$

$$\text{or } \frac{R_1(R_3 - j L_3)}{1 - j CR_1} = R_2 R_4 \text{ or } R_1 R_3 - j L_3 R_1 = R_2 R_4 - j CR_1 R_2 R_4$$

Separating the real and imaginaries, we get

$$R_1 R_3 = R_2 R_4 \text{ and } L_3 R_1 = C R_1 R_2 R_4; R_3 = \frac{R_2 R_4}{R_1} \text{ and } L_3 = C R_2 R_4$$

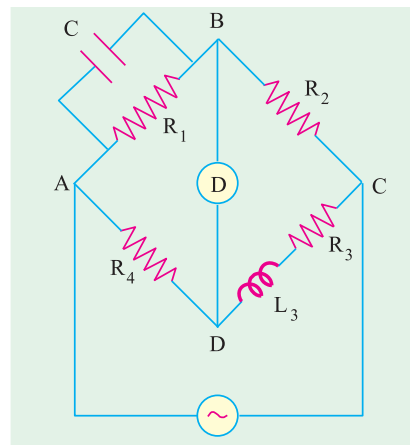

Fig. 16.5

Example 16.2. The arms of an a.c. Maxwell bridge are arranged as follows: AB is a non-inductive resistance of $1,000 \Omega$ in parallel with a capacitor of capacitance $0.5 \mu F$, BC is a non-inductive resistance of 600Ω , CD is an inductive impedance (unknown) and DA is a non-inductive resistance of 400Ω . If balance is obtained under these conditions, find the value of the resistance and the inductance of the branch CD.

[Elect. & Electronic Meas, Madras Univ.]

Solution. The bridge is shown in Fig. 16.6. The conditions of balance have already been derived in Art. 16.3 above.

$$\text{Since } R_1 R_3 = R_2 R_4 \therefore R_3 = R_2 R_4 / R_1$$

$$\therefore R_3 = \frac{600 \times 400}{1000} = 240 \Omega$$

$$\begin{aligned} \text{Also } L_3 &= CR_2 R_4 \\ &= 0.5 \times 10^{-6} \times 400 \times 600 \\ &= 12 \times 10^{-2} = 0.12 \text{ H} \end{aligned}$$

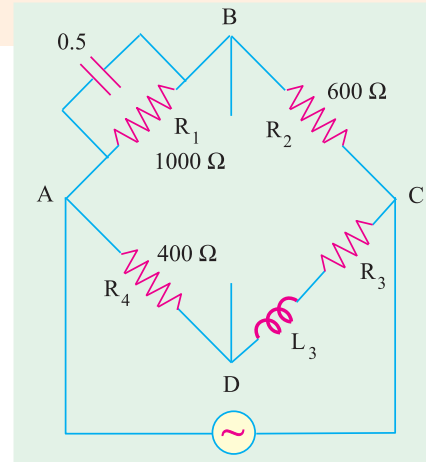

Fig. 16.6

16.4. Anderson Bridge

It is a very important and useful modification of the Maxwell-Wien bridge described in Art. 16.3. In this method, the unknown inductance is measured in terms of a known capacitance and resistance, as shown in Fig. 16.7.

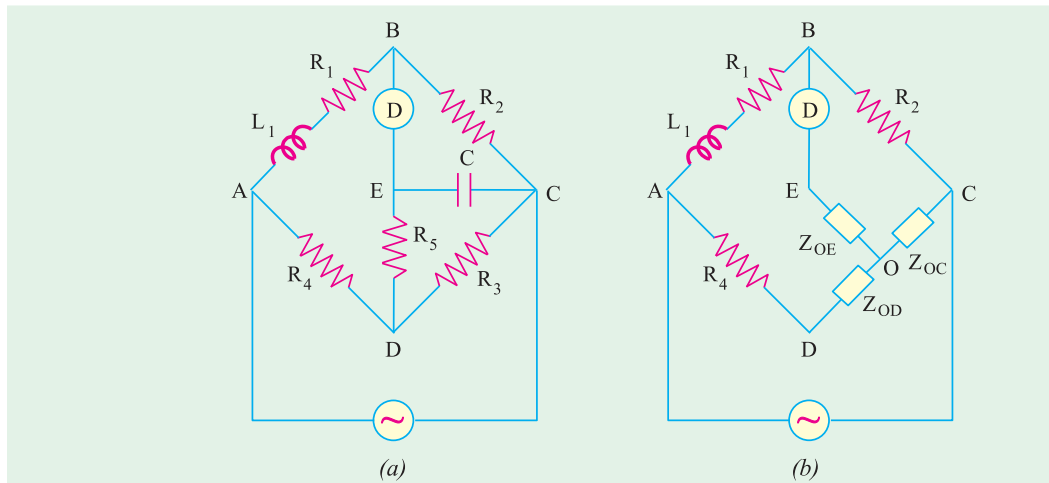

Fig. 16.7

The balance conditions for this bridge may be easily obtained by converting the mesh of impedances C , R_5 and R_3 to an equivalent star with star point O by Δ/Y transformation. As seen from Fig. 16.7 (b).

$$Z_{OD} = \frac{R_3 R_5}{(R_3 + R_5 + 1/jC)}; \quad Z_{OC} = \frac{R_3 / jC}{(R_3 + R_5 + 1/jC)} \quad Z_3$$

With reference to Fig. 16.7 (b) it is seen that

$$Z_1 = (R_1 + j\omega L_1) \quad Z_2 = R_2; \quad Z_3 = Z_{OC} \quad \text{and} \quad Z_4 = R_4 + Z_{OD}$$

For balance $Z_1 Z_3 = Z_2 Z_4 \therefore (R_1 + j L_1) Z_{OC} = R_2 (R_4 + Z_{OD})$

$$\therefore (R_1 + j L_1) \frac{R_3 / j C}{(R_3 + R_5 - 1/j C)} = R_2 R_4 \frac{R_3 R_5}{R_3 + R_5 - 1/j C}$$

Further simplification leads to $R_2 R_3 R_4 = R_2 R_4 R_5 + j \frac{R_2 R_4}{C} = R_2 R_3 R_5 + j \frac{R_1 R_3}{C} = \frac{R_3 L_1}{C}$

$$\therefore \frac{j R_2 R_4}{C} = \frac{j R_1 R_3}{C} \text{ or } R_1 = R_2 R_4 / R_3$$

$$\text{Also } \frac{R_3 L_1}{C} = R_2 R_3 R_4 = R_2 R_3 R_5 + R_2 R_4 R_5 \therefore L_1 = C R_2 (R_4 + R_5) + \frac{R_4 R_5}{R_3}$$

This method is capable of precise measurements of inductances over a wide range of values from a few micro-henrys to several henrys and is one of the commonest and the best bridge methods.

Example 16.3. An alternating current bridge is arranged as follows: The arms AB and BC consists of non-inductive resistances of 100-ohm each, the arms BE and CD of non-inductive variable resistances, the arm EC of a capacitor of 1 μF capacitance, the arm DA of an inductive resistance. The alternating current source is connected to A and C and the telephone receiver to E and D. A balance is obtained when resistances of arms CD and BE are 50 and 2,500 ohm respectively. Calculate the resistance and inductance of arm DA.

Draw the vector diagram showing voltage at every point of the network.

(Elect. Measurements, Pune Univ.)

Solution. The circuit diagram and voltage vector diagram are shown in Fig. 16.8. As seen, I_2 is vector sum of I_C and I_3 . Voltage $V_2 = I_2 R_2 = I_C X_C$. Also, vector sum of V_1 and V_2 is V as well as that of V_3 and V_4 . I_C is at right angles to V_2 .

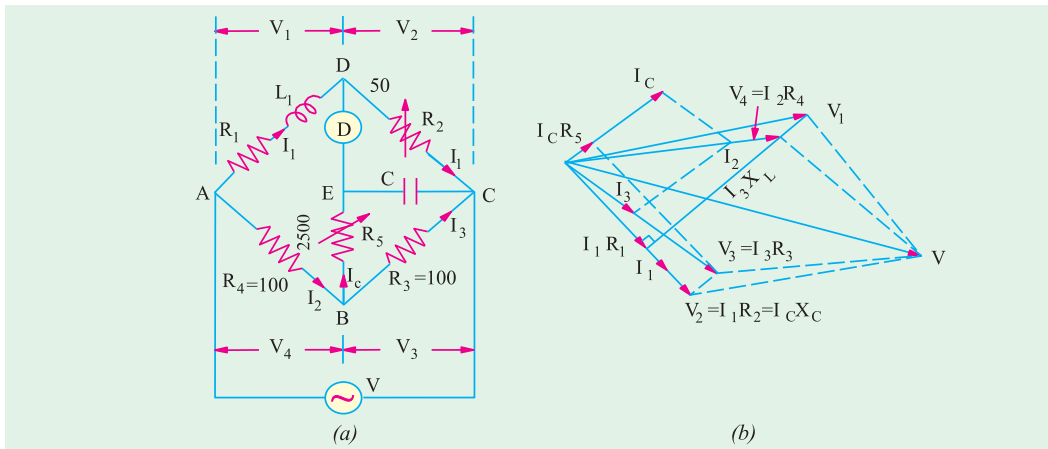

Fig. 16.8

Similarly, V_3 is the vector sum of V_2 and $I_C R_5$.

As shown in Fig. 16.8, $R_1 = R_2$. $R_4/R_3 = 50 \times 100/100 = 50 \Omega$

The inductance is given by $L = C R_2 (R_4 + R_5 + R_4 R_5 / R_3)$

$$\therefore L = 1 \times 10^{-6} (50(100 + 2500 + 100 \times 2500/100)) = 0.2505 \text{ H}$$

Example 16.4. Fig. 16.9 gives the connection of Anderson's bridge for measuring the inductance L_1 and resistance R_1 of a coil. Find R_1 and L_1 if balance is obtained when $R_3 = R_4 = 2000$ ohms, $R_2 = 1000$ ohms $R_5 = 200$ ohms and $C = 1\mu F$. Draw the vector diagram for the voltages and currents in the branches of the bridge at balance.

(Elect. Measurements, AMIE Sec. B Summer 1990)

Solution. $R_1 = R_2 R_4 / R_3 = 1000 \times 2000 / 2000 = 1000 \Omega$

$$L_1 = CR_2 \frac{R_4 R_5}{R_3} = 1 \times 10^{-6} \times 1000 \times 2000 \times 200 \frac{2000}{2000} = 2.4 \text{ H}$$

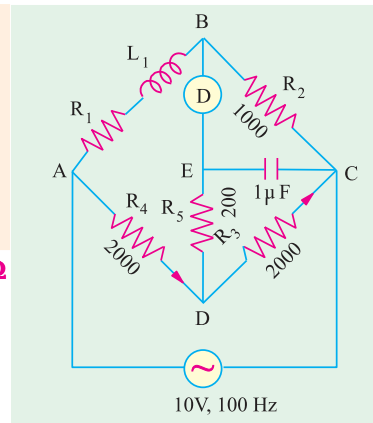

Fig. 16.9

16.5. Hay's Bridge

It is also a modification of the Maxwell-Wien bridge and is particularly useful if the phase angle of the inductive impedance $\tan^{-1}(L/R)$ is large. The network is shown in Fig. 16.10. It is seen that, in this case, a comparatively smaller series resistance R_1 is used instead of a parallel resistance (which has to be of a very large value).

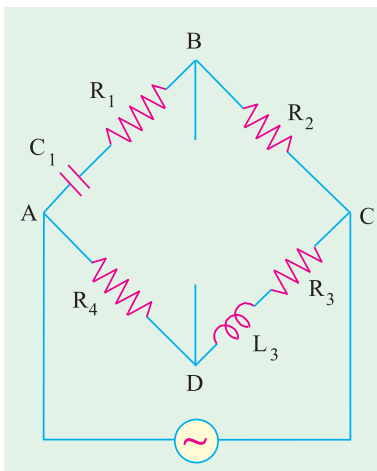

Fig. 16.10

Here $Z_1 = R_1 - \frac{j}{C_1}$; $Z_2 = R_2$

$Z_3 = R_3 + j L_3$; $Z_4 = R_4$

Balance condition is $Z_1 Z_3 = Z_2 Z_4$

or $R_1 - \frac{j}{C_1} (R_3 + j L_3) = R_2 R_4$

Separating the reals and the imaginaries, we obtain

$R_1 R_3 - \frac{L_3}{C_1} = R_2 R_4$ and $L_3 R_1 = \frac{R_3}{C_1}$

Solving these simultaneous equations, we get

$L_3 = \frac{C_1 R_2 R_4}{1 - \frac{R_3^2}{R_1^2 C_1^2}}$ and $R_3 = \frac{R_1^2 C_1^2 R_2 R_4}{1 - \frac{R_3^2}{R_1^2 C_1^2}}$

The symmetry of expressions should help the readers to remember the results even when branch elements are exchanged, as in Ex. 16.5.

Example 16.5. The four arms of a Hay's a.c. bridge are arranged as follows: AB is a coil of unknown impedance; BC is a non-reactive resistor of 1000Ω ; CD is a non-reactive resistor of 833Ω in series with a standard capacitor of $0.38 \mu F$; DA is a non-reactive resistor of $16,800 \Omega$. If the supply frequency is 50 Hz , determine the inductance and the resistance at the balance condition.

(Elect. Measu. A.M.I.E. Sec B, 1992)

Solution. The bridge circuit is shown in Fig. 16.11.

$277 \times 50 = 314.22 \text{ rad/s}; \quad \frac{1}{0.38 \times 10^{-6}} = 2.63 \times 10^6$

$$R_1 = \frac{98,721 (0.38 \times 10^{-6})^2}{1 \times 98,721 \times 833^2} \frac{833 \times 16,800 \times 1000}{(0.38 \times 10^{-6})^2} = 210 \Omega$$

$$L_1 = \frac{16,800 \times 1000 \times 0.38 \times 10^{-6}}{1 \times 98,721 \times 833^2} = 6.38 \text{ H}$$

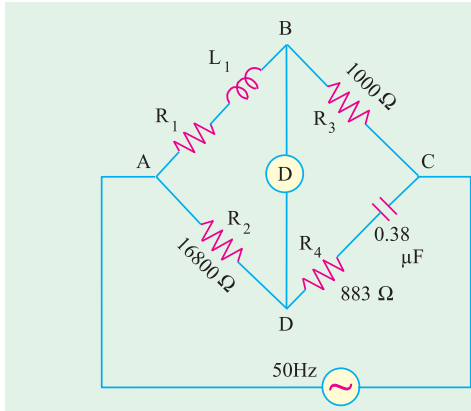

Fig. 16.11

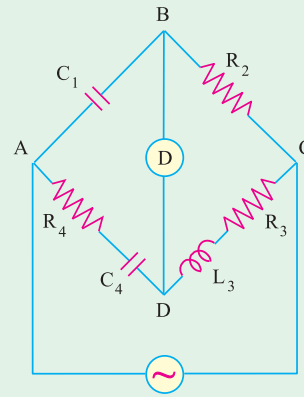

Fig. 16.12

16.6. The Owen Bridge

The arrangement of this bridge is shown in Fig. 16.12. In this method, also, the inductance is determined in terms of resistance and capacitance. This method has, however, the advantage of being useful over a very wide range of inductances with capacitors of reasonable dimensions.

Balance condition is $Z_1 Z_3 = Z_2 Z_4$

$$\text{Here } Z_1 = -\frac{j}{\omega C_1}; \quad Z_2 = R_2; Z_3 = R_3 + j L_3; Z_4 = R_4 + \frac{j}{C_4}$$

$$\therefore -\frac{j}{C_1} (R_3 + j L_3) = R_2 R_4 + \frac{j}{C_4}$$

Separating the reals and imaginaries, we get $R_3 = R_2 \frac{C_1}{C_4}$ and $L_3 = C_1 R_2 R_4$.

Since ω does not appear in the final balance equations, hence the bridge is unaffected by frequency variations and wave-form.

16.7. Heaviside-Campbell Equal Ratio Bridge

It is a mutual inductance bridge and is used for measuring self-inductance over a wide range in terms of mutual inductometer readings. The connections for Heaviside's bridge employing a standard variable mutual inductance are shown in Fig. 16.13. The primary of the mutual inductometer is inserted in the supply circuit and the secondary having self-inductance L_2 and resistance R_2 is put in arm 2 of the bridge. The unknown inductive impedance having self-inductance of L_1 and resistance R_1 is placed in arm 1. The other two arms have pure resistances of R_3 and R_4 .

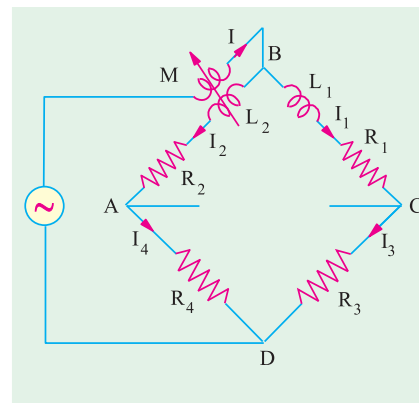

Fig. 16.13

Balance is obtained by varying mutual inductance M and resistances R_3 and R_4 .

For balance, $I_1 R_3 = I_2 R_4$... (i)

$$I_1(R_1 + j L_1) = I_2(R_2 + j L_2) + j M I \quad \dots (ii)$$

Since $I = I_1 + I_2$, hence putting the value of I in equation (ii), we get

$$I_1[R_1 + j(L_1 + M)] = I_2[R_2 + j(L_2 + M)] \quad \dots (iii)$$

Dividing equation (iii) by (i), we have $\frac{R_1 + j(L_1 + M)}{R_3} = \frac{R_2 + j(L_2 + M)}{R_4}$

$$\therefore R_3[R_2 + j(L_2 + M)] = R_4[R_1 + j(L_1 + M)]$$

Equating the real and imaginaries, we have $R_2 R_3 = R_1 R_4$... (iv)

Also, $R_3(L_2 + M) = R_4(L_1 + M)$. If $R_3 = R_4$, then $L_2 + M = L_1 + M \therefore L_1 - L_2 = 2M$... (v)

This bridge, as modified by Campbell, is shown in Fig. 16.14. Here $R_3 = R_4$. A balancing coil or a test coil of self-inductance equal to the self-inductance L_2 of the secondary of the inductometer and of resistance slightly greater than R_2 is connected in series with the unknown inductive impedance (R_1 and L_1) in arm 1. A non-inductive resistance box along with a constant-inductance rheostat are also introduced in arm 2 as shown.

Balance is obtained by varying M and r . Two readings are taken; one when Z_1 is in circuit and second when Z_1 is removed or short-circuited across its terminals.

With unknown impedance Z_1 still in circuit, suppose for balance the values of mutual inductance and r are M_1 and r_1 . With Z_1 short-circuited, let these values be M_2 and r_2 . Then

$$L_1 = 2(M_1 - M_2) \text{ and } R_1 = r_1 - r_2$$

By this method, the self-inductance and resistance of the leads are eliminated.

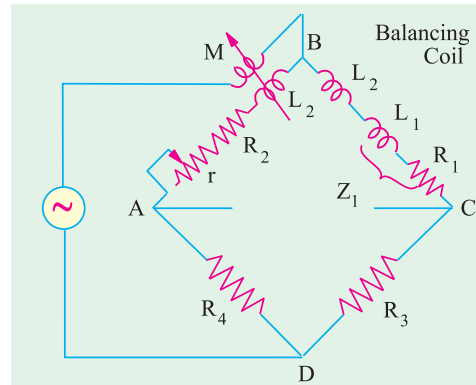

Fig. 16.14

Example 16.6. The inductance of a coil is measured by using the Heaviside-Campbell equal ratio bridge. With the test coil short-circuited, balance is obtained when adjustable non-reactive resistance is 12.63Ω and mutual inductometer is set at 0.1 mH . When the test coil is in circuit, balance is obtained when the adjustable resistance is 25.9Ω and mutual inductometer is set at 15.9 mH . What is the resistance and inductance of the coil?

Solution. With reference to Art. 16.7 and Fig. 16.14, $r_1 = 25.9 \Omega$, $M_1 = 15.9 \text{ mH}$

With test coil short-circuited $r_2 = 12.63 \Omega$; $M_2 = 0.1 \text{ mH}$

$$L_1 = 2(M_1 - M_2) = 2(15.9 - 0.1) = \mathbf{31.6 \text{ mH}}$$

$$R_1 = r_1 - r_2 = 25.9 - 12.63 = \mathbf{13.27 \Omega}$$

16.8. Capacitance Bridges

We will consider only De Sauty bridge method of comparing two capacitances and Schering bridge used for the measurement of capacitance and dielectric loss.

16.9. De Sauty Bridge

With reference to Fig. 16.15, let

C_2 = capacitor whose capacitance is to be measured

C_3 = a standard capacitor

R_1, R_2 = non-inductive resistors

Balance is obtained by varying either R_1 or R_2 .

For balance, points B and D are at the same potential.

$$\therefore I_1 R_1 = I_2 R_2 \text{ and } \frac{j}{C_2} \cdot I_1 = \frac{j}{C_3} \cdot I_2$$

Dividing one equation by the other, we get

$$\frac{R_1}{R_2} = \frac{C_2}{C_3}, \quad C_2 = C_3 \frac{R_1}{R_2}$$

The bridge has maximum sensitivity when $C_2 = C_3$. The simplicity of this method is offset by the impossibility of obtaining a perfect balance if both the capacitors are not free from the dielectric loss. A perfect balance can only be obtained if air capacitors are used.

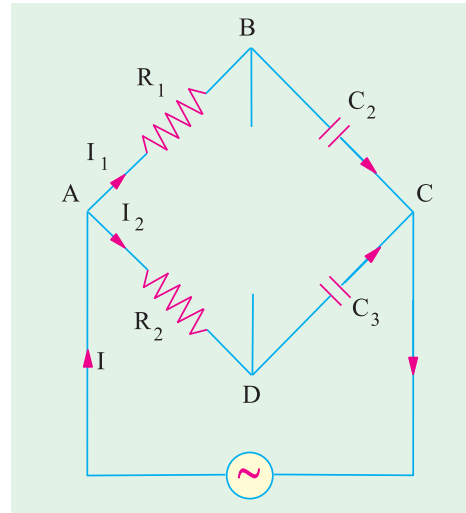

Fig. 16.15

16.10. Schering Bridge

It is one of the very important and useful methods of measuring the capacitance and dielectric loss of a capacitor. In fact, it is a device for comparing an imperfect capacitor C_2 in terms of a loss-free standard capacitor C_1 [Fig. 16.16 (a)]. The imperfect capacitor is represented by its equivalent loss-free capacitor C_2 in series with a resistance r [Fig. 16.16 (b)].

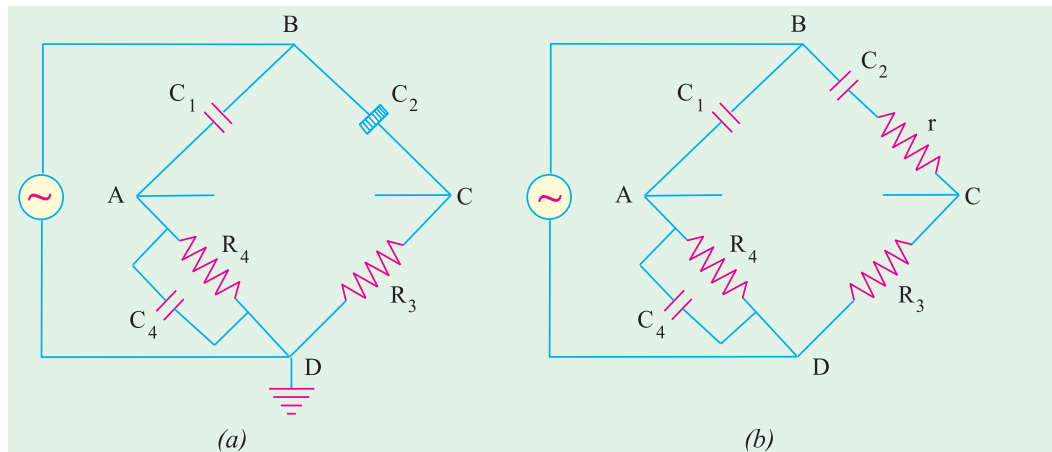

Fig. 16.16

For high voltage applications, the voltage is applied at the junctions shown in the figure. The junction between arms 3 and 4 is earthed. Since capacitor impedances at lower frequencies are much higher than resistances, most of the voltage will appear across capacitors. Grounding of the junction affords safety to the operator from the high-voltage hazards while making balancing adjustment in arms 3 and 4.

$$\text{Now } Z_1 = \frac{j}{C_1}; Z_2 = r + \frac{j}{C_2}; Z_3 = R_3; Z_4 = \frac{1}{(1/R_4) + j C_4} = \frac{R_4}{1 + j C_4 R_4}$$

For balance, $Z_1 Z_3 = Z_2 Z_4$

$$\text{or } \frac{jR_3}{C_1} + r = \frac{j}{C_2} \frac{R_4}{1 + jC_4R_4} \quad \text{or } \frac{jR_3}{C_1}(1 + jC_4R_4) + R_4 + r = \frac{j}{C_2}$$

Separating the real and imaginaries, we have $C_2 = C_1(R_4/R_3)$ and $r = R_3.(C_4/C_1)$.

The quality of a capacitor is usually expressed in terms of its phase defect angle or dielectric loss angle which is defined as the angle by **which current departs from exact quadrature from the applied voltage** i.e. the complement of the phase angle. If ϕ is the actual phase angle and δ

the defect angle, then $\phi + \delta = 90^\circ$. For small values of δ , $\tan \delta = \sin \delta = \cos \phi$ (approximately). $\tan \delta$ is usually called the *dissipation factor* of the $R-C$ circuit. For low power factors, therefore, dissipation factor is approximately equal to the power factor.

As shown in Fig. 16.17,

Dissipation factor = power factor = $\tan \delta$

$$= \frac{r}{X_C} = \frac{r}{1/\omega C_2} = \omega r C_2$$

Putting the value of rC_2 from above,

Dissipation factor = $rC_2 = C_4R_4 =$ power factor.

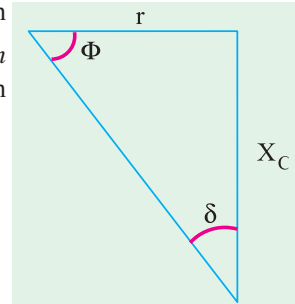

Fig. 16.17

Example 16.7. In a test on a bakelite sample at 20 kV, 50 Hz by a Schering bridge, having a standard capacitor of 106 pF, balance was obtained with a capacitance of 0.35 μF in parallel with a non-inductive resistance of 318 ohms, the non-inductive resistance in the remaining arm of the bridge being 130 ohms. Determine the capacitance, the p.f. and equivalent series resistance of the specimen. Derive any formula used. Indicate the precautions to be observed for avoiding errors. (Elect. Engg. Paper I, Indian Engg. Services 1991)

Solution. Here $C_1 = 106 \text{ pF}$, $C_4 = 0.35 \text{ } \mu\text{F}$, $R_4 = 318 \text{ } \Omega$, $R_3 = 130 \text{ } \Omega$.

$$C_2 = C_1.(R_4/R_3) = 106 \cdot 318/130 = \mathbf{259.3 \text{ pF}}$$

$$r = R_3.(C_4/C_1) = 130 \cdot 0.35 \cdot 10^{-6}/106 \cdot 10^{-12} = \mathbf{0.429 \text{ M}\Omega}$$

$$\text{p.f.} = rC_2 = (2 \cdot 50) \cdot 0.429 \cdot 10^6 \cdot 259.3 \cdot 10^{-12} = \mathbf{0.035}$$

Example 16.8. A lossy capacitor is tested with a Schering bridge circuit. Balance obtained with the capacitor under test in one arm, the succeeding arms being, a non-inductive resistor of 100 Ω , a non-reactive resistor of 309 Ω in parallel with a pure capacitor of 0.5 μF and a standard capacitor of 109 μF . The supply frequency is 50 Hz. Calculate from the equation at balance the equivalent series capacitance and power factor (at 50 Hz) of the capacitor under test. (Measu. & Instru., Nagpur Univ. 1992)

Solution. Here, we are given

$$C_1 = 109 \text{ pF}; R_3 = 100 \text{ } \Omega; C_4 = 0.5 \text{ } \mu\text{F}; R_4 = 309 \text{ } \Omega$$

Equivalent capacitance is $C_2 = 109 \cdot 309/100 = \mathbf{336.8 \text{ pF}}$

$$\text{p.f.} = C_4R_4 = 314 \cdot 0.5 \cdot 10^{-6} \cdot 309 = \mathbf{0.0485}$$

16.11. Wien Series Bridge

It is a simple ratio bridge and is used for audio-frequency measurement of capacitors over a wide range. The bridge circuit is shown in Fig. 16.18.

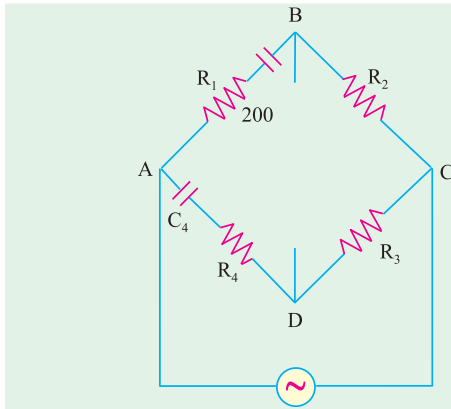

Fig. 16.18

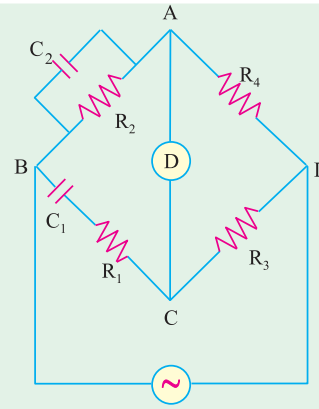

Fig. 16.19

The balance conditions may be obtained in the usual way. For balance

$$R_1 = R_2 R_4 / R_3 \quad \text{and} \quad C_1 = C_4 (R_3 / R_2)$$

16.12. Wien Parallel Bridge

It is also a ratio bridge used mainly as the feedback network in the wide-range audio-frequency R - C oscillators. It may be used for measuring audio-frequencies although it is not as accurate as the modern digital frequency meters.

The bridge circuit is shown in Fig. 16.19. In the simple theory of this bridge, capacitors C_1 and C_2 are assumed to be loss-free and resistances R_1 and R_2 are separate resistors.

The usual relationship for balance gives

$$R_4 R_1 \frac{j}{C_1} = R_3 \frac{R_2}{1 - j C_2 R_2} \quad \text{or} \quad R_4 R_1 \frac{j}{C_1} (1 - j C_2 R_2) = R_2 R_3$$

Separating the real and imaginary terms, we have

$$R_1 R_4 = R_2 R_3 \frac{C_2}{C_1} \quad \text{or} \quad \frac{C_2}{C_1} = \frac{R_3}{R_4} \frac{R_1}{R_2} \quad \dots (i)$$

$$\text{and} \quad C_2 R_2 R_4 = \frac{R_4}{C_1} \cdot 0 \quad \text{or} \quad \frac{1}{R_1 R_2 C_1 C_2} \quad \dots (ii)$$

or

$$f = \frac{1}{2 \sqrt{R_1 R_2 C_1 C_2}} \text{ Hz}$$

Note. Eq. (ii) may be used to find angular frequency ω of the source if terms are known. For such purposes, it is convenient to make $C_1 = 2C_2$, $R_3 = R_4$ and $R_2 = 2R_1$. In that case, the bridge has equal ratio arms so that Eq. (i) will always be satisfied. The bridge is balanced simultaneously by adjusting R_2 and R_1 (though maintaining $R_2 = 2R_1$). Then, as seen from Eq. (ii) above

$$\frac{1}{2 \sqrt{R_1 \cdot 2R_1 \cdot 2C_2 \cdot C_2}} \quad \text{or} \quad \frac{1}{2 \sqrt{R_1 C_2}}$$

Example 16.9. The arms of a four-arm bridge $ABCD$, supplied with a sinusoidal voltage, have the following values:

AB : 200 ohm resistance in parallel with $1 \mu\text{F}$ capacitor; BC : 400 ohm resistance; CD : 1000 ohm resistance and DA : resistance R in series with a $2\mu\text{F}$ capacitor.

Determine (i) the value of R and (ii) the supply frequency at which the bridge will be balanced. (Elect. Meas. A.M.I.E. Sec. 1991)

Solution. The bridge circuit is shown in Fig. 16.20.

(i) As discussed in Art. 16.12, for balance we have

$$\frac{C_2}{C_1} \frac{R_3}{R_4} \frac{R_1}{R_2} \text{ or } \frac{2}{1} \frac{1000}{4000} \frac{R_1}{200}$$

$$\therefore R_1 = 200 \times 0.5 = \mathbf{100 \Omega}$$

(ii) The frequency at which bridge is balanced is given by

$$f = \frac{1}{2 \sqrt{R_1 R_2 C_1 C_2}} \text{ Hz}$$

$$= \frac{10^6}{2 \sqrt{100 \times 200 \times 1 \times 2}} = \mathbf{796 \text{ Hz}}$$

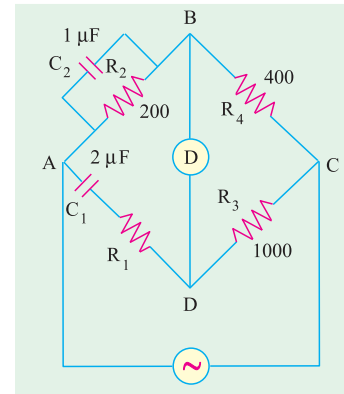

Fig. 16.20

Tutorial Problems No. 16.1

- In Anderson a.c. bridge, an impedance of inductance L and resistance R is connected between A and B . For balance following data is obtained. An ohmic resistance of 1000Ω each in arms AD and CD , a non-inductive resistance of 500Ω in BC , a pure resistance of 200Ω between points D and E and a capacitor of $2 \mu\text{F}$ between C and E . The supply is 10 volt (A.C.) at a frequency of 100 Hz and is connected across points A and C . Find L and R . [1.4 H ; 500Ω]
- A balanced bridge has the following components connected between its five nodes, A, B, C, D and E :
Between A and B : 1,000 ohm resistance; Between B and C : 1,000 ohm resistance
Between C and D : an inductor; Between D and A : 218 ohm resistance
Between A and E : 469 ohm resistance; Between E and B : $10 \mu\text{F}$ capacitance
Between E and C : a detector; Between B and D : a power supply (a.c.)
Derive the equations of balance and hence deduce the resistance and inductance of the inductor.

[$R = 218 \Omega$, $L = 7.89 \text{ H}$] (*Elect. Theory and Meas. London Univ.*)

- An a.c. bridge is arranged as follows: The arms AB and BC consist of non-inductive resistance of 100Ω , the arms, BE and CD of non-inductive variable resistances, the arm EC of a capacitor of $1 \mu\text{F}$ capacitance, the arm DA of an inductive resistance. The a.c. source is connected to A and C and the telephone receiver to E and D . A balance is obtained when the resistances of the arms CD and BE are 50Ω and 2500Ω respectively.

Calculate the resistance and the inductance of the arm DA .
What would be the effect of harmonics in the waveform of the alternating current source? [50Ω ; 0.25 H]

- For the Anderson's bridge of Fig. 16.21, the values are underbalance conditions. Determine the values of unknown resistance R and inductance L . [$R = 500 \Omega$; $L = 1.5 \text{ H}$]

(*Elect. Meas & Inst. Madras Univ. Nov. 1978*)

- An Anderson's bridge is arranged as under and balanced for the following values of the bridge components:
Branch AB – unknown coil of inductance L and resistance R
Branch BC – non-inductive resistance of 500Ω
Branches AD & CD – non-inductive resistance of 100Ω each
Branch DE – non-inductive resistance of 200Ω
Branch EB – vibration galvanometer
Branch EC – $2.0 \mu\text{F}$ capacitance
Between A and C is 10 V, 100-Hz a.c. supply. Find the values of R and L of the unknown coil.

[$R = 500 \Omega$; $L = 0.5 \text{ H}$] (*Elect. Meas & Meas. Inst., Gujarat Univ.*)

- An a.c. Anderson bridge is arranged as follows:
(i) branches BC and ED are variable non-reactive resistors
(ii) branches CD and DA are non-reactive resistors of 200 ohm each
(iii) branch CE is a loss-free capacitor of $1 \mu\text{F}$ capacitance.

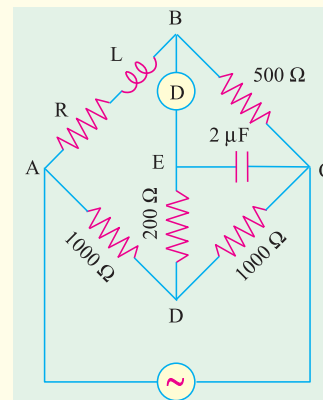

Fig. 16.21

The supply is connected across A and C and the detector across B and E . Balance is obtained when the resistance of BC is 400 ohm and that of ED is 500 ohm. Calculate the resistance and inductance of AB .

Derive the relation used and draw the vector diagram for balanced condition of the bridge.

[400 Ω ; 0.48 H] (*Elect. Measurements, Poona Univ.*)

7. In a balanced bridge network, AB is a resistance of 500 ohm in series with an inductance of 0.18 henry, the non-inductive resistances BC and DA have values of 1000 ohm and arm CD consists of a capacitance of C in series with a resistance R . A potential difference of 5 volts at a frequency $5000/2\pi$ is the supply between the points A and C . Find out the values of R and C and draw the vector diagram.

[472 Ω ; 0.235 μF] (*Elect. Measurements, Poona Univ.*)

8. A sample of bakelite was tested by the Schering bridge method at 25 kV, 50-Hz. Balance was obtained with a standard capacitor of 106 pF capacitance, a capacitor of capacitance 0.4 μF in parallel with a non-reactive resistor of 318 Ω and a non-reactive resistor of 120 Ω . Determine the capacitance, the equivalent series resistance and the power factor of the specimen. Draw the phase or diagram for the balanced bridge.

[281 pF ; 0.452 M Ω ; 0.04] (*Elect. Measurements-II; Bangalore Univ.*)

9. The conditions at balance of a Schering bridge set up to measure the capacitance and loss angle of a paper dielectric capacitor are as follows:

$$f = 500 \text{ Hz}$$

$$Z_1 = \text{a pure capacitance of } 0.1 \mu\text{F}$$

$$Z_2 = \text{a resistance of } 500 \Omega \text{ shunted by a capacitance of } 0.0033 \mu\text{F}$$

$$Z_3 = \text{pure resistance of } 163 \Omega$$

$$Z_4 = \text{the capacitor under test}$$

Calculate the approximate values of the loss resistance of the capacitor assuming—

(a) series loss resistance (b) shunt loss resistance. [5.37 Ω , 197,000 Ω] (*London Univ.*)

10. Name and draw the bridge used for measurements of Inductance. (*Anna University, April 2002*)

11. A Wheat-stone bridge network has the following resistances :

$$AB = 10\Omega, BC = 15\Omega, CD = 25\Omega, DA = 20\Omega \text{ and } BD = 10\Omega$$

(*V.T.U., Belgaum Karnataka University, February 2002*)

OBJECTIVE TESTS – 16

- Maxwell-Wien bridge is used for measuring
 - capacitance
 - dielectric loss
 - inductance
 - phase angle
- Maxwell's L/C bridge is so called because
 - it employs L and C in two arms
 - ratio L/C remains constant
 - for balance, it uses two opposite impedances in opposite arms
 - balance is obtained when $L = C$
- bridge is used for measuring an unknown inductance in terms of a known capacitance and resistance.
 - Maxwell's L/C
 - Hay's
 - Owen
 - Anderson
- Anderson bridge is a modification of bridge.
 - Owen
 - Hay's
 - De Sauty
 - Maxwell-Wien
- Hay's bridge is particularly useful for measuring
 - inductive impedance with large phase angle
 - mutual inductance
 - self inductance
 - capacitance and dielectric loss
- The most useful ac bridge for comparing capacitances of two air capacitors is bridge.
 - Schering
 - De Sauty
 - Wien series
 - Wien parallel
- Heaviside-Campbell Equal Ratio bridge is used for measuring
 - self-inductance in terms of mutual inductance
 - capacitance in terms of inductance
 - dielectric loss of an imperfect capacitor
 - phase angle of a coil

ANSWERS

1. c 2. c 3. d 4. d 5. a 6. b 7. a