

Power (ac)

19.1 INTRODUCTION

The discussion of power in Chapter 14 included only the average power delivered to an ac network. We will now examine the total power equation in a slightly different form and will introduce two additional types of power: **apparent** and **reactive**.

For any system such as in Fig. 19.1, the power delivered to a load at any instant is defined by the product of the applied voltage and the resulting current; that is,

$$p = vi$$

In this case, since v and i are sinusoidal quantities, let us establish a general case where

$$v = V_m \sin(\omega t + \theta)$$

and

$$i = I_m \sin \omega t$$

The chosen v and i include all possibilities because, if the load is purely resistive, $\theta = 0^\circ$. If the load is purely inductive or capacitive, $\theta = 90^\circ$ or $\theta = -90^\circ$, respectively. For a network that is primarily inductive, θ is positive (v leads i), and for a network that is primarily capacitive, θ is negative (i leads v).

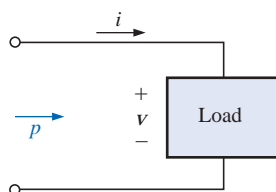

FIG. 19.1

Defining the power delivered to a load.

Substituting the above equations for v and i into the power equation will result in

$$p = V_m I_m \sin \omega t \sin(\omega t + \theta)$$

If we now apply a number of trigonometric identities, the following form for the power equation will result:

$$p = VI \cos \theta (1 - \cos 2\omega t) + VI \sin \theta (\sin 2\omega t) \quad (19.1)$$

where V and I are the rms values. The conversion from peak values V_m and I_m to rms values resulted from the operations performed using the trigonometric identities.

It would appear initially that nothing has been gained by putting the equation in this form. However, the usefulness of the form of Eq. (19.1) will be demonstrated in the following sections. The derivation of Eq. (19.1) from the initial form will appear as an assignment at the end of the chapter.

If Equation (19.1) is expanded to the form

$$p = \underbrace{VI \cos \theta}_{\text{Average}} - \underbrace{VI \cos \theta}_{\text{Peak}} \underbrace{\cos 2\omega t}_{2x} + \underbrace{VI \sin \theta}_{\text{Peak}} \underbrace{\sin 2\omega t}_{2x}$$

there are two obvious points that can be made. First, the average power still appears as an isolated term that is time independent. Second, both terms that follow vary at a frequency twice that of the applied voltage or current, with peak values having a very similar format.

In an effort to ensure completeness and order in presentation, each basic element (R , L , and C) will be treated separately.

19.2 RESISTIVE CIRCUIT

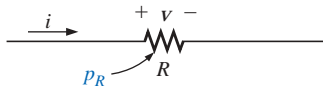

FIG. 19.2
Determining the power delivered to a purely resistive load.

For a purely resistive circuit (such as that in Fig. 19.2), v and i are in phase, and $\theta = 0^\circ$, as appearing in Fig. 19.3. Substituting $\theta = 0^\circ$ into Eq. (19.1), we obtain

$$\begin{aligned} p_R &= VI \cos(0^\circ)(1 - \cos 2\omega t) + VI \sin(0^\circ) \sin 2\omega t \\ &= VI(1 - \cos 2\omega t) + 0 \end{aligned}$$

or

$$p_R = VI - VI \cos 2\omega t \quad (19.2)$$

where VI is the average or dc term and $-VI \cos 2\omega t$ is a negative cosine wave with twice the frequency of either input quantity (v or i) and a peak value of VI .

Plotting the waveform for p_R (Fig. 19.3), we see that

$$T_1 = \text{period of input quantities}$$

$$T_2 = \text{period of power curve } p_R$$

Note that in Fig. 19.3 the power curve passes through two cycles about its average value of VI for each cycle of either v or i ($T_1 = 2T_2$ or $f_2 = 2f_1$). Consider also that since the peak and average values of the power curve are the same, the curve is always above the horizontal axis. This indicates that

the total power delivered to a resistor will be dissipated in the form of heat.

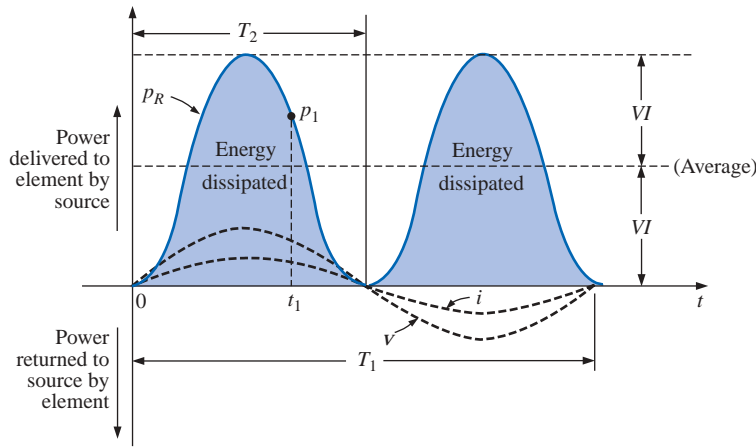

FIG. 19.3
Power versus time for a purely resistive load.

The power returned to the source is represented by the portion of the curve below the axis, which is zero in this case. The power dissipated by the resistor at any instant of time t_1 can be found by simply substituting the time t_1 into Eq. (19.2) to find p_1 , as indicated in Fig. 19.3. The **average (real) power** from Eq. (19.2), or Fig. 19.3, is VI ; or, as a summary,

$$P = VI = \frac{V_m I_m}{2} = I^2 R = \frac{V^2}{R} \quad (\text{watts, W}) \quad (19.3)$$

as derived in Chapter 14.

The energy dissipated by the resistor (W_R) over one full cycle of the applied voltage (Fig. 19.3) can be found using the following equation:

$$W = Pt$$

where P is the average value and t is the period of the applied voltage; that is,

$$W_R = VIT_1 \quad (\text{joules, J}) \quad (19.4)$$

or, since $T_1 = 1/f_1$,

$$W_R = \frac{VI}{f_1} \quad (\text{joules, J}) \quad (19.5)$$

19.3 APPARENT POWER

From our analysis of dc networks (and resistive elements above), it would seem *apparent* that the power delivered to the load of Fig. 19.4 is simply determined by the product of the applied voltage and current, with no concern for the components of the load; that is, $P = VI$. However, we found in Chapter 14 that the power factor ($\cos \theta$) of the load will have a pronounced effect on the power dissipated, less pronounced for more reactive loads. Although the product of the voltage and current is not always the power delivered, it is a power rating of significant use-

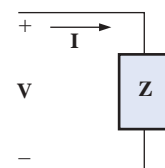

FIG. 19.4
Defining the apparent power to a load.

fulness in the description and analysis of sinusoidal ac networks and in the maximum rating of a number of electrical components and systems. It is called the **apparent power** and is represented symbolically by S .^{*} Since it is simply the product of voltage and current, its units are *volt-amperes*, for which the abbreviation is VA. Its magnitude is determined by

$$S = VI \quad (\text{volt-amperes, VA}) \quad (19.6)$$

or, since $V = IZ$ and $I = \frac{V}{Z}$

then $S = I^2Z$ (VA) (19.7)

and $S = \frac{V^2}{Z}$ (VA) (19.8)

The average power to the load of Fig. 19.4 is

$$P = VI \cos \theta$$

However, $S = VI$

Therefore, $P = S \cos \theta$ (W) (19.9)

and the power factor of a system F_p is

$$F_p = \cos \theta = \frac{P}{S} \quad (\text{unitless}) \quad (19.10)$$

The power factor of a circuit, therefore, is the ratio of the average power to the apparent power. For a purely resistive circuit, we have

$$P = VI = S$$

and $F_p = \cos \theta = \frac{P}{S} = 1$

In general, power equipment is rated in volt-amperes (VA) or in kilovolt-amperes (kVA) and not in watts. By knowing the volt-ampere rating and the rated voltage of a device, we can readily determine the *maximum* current rating. For example, a device rated at 10 kVA at 200 V has a maximum current rating of $I = 10,000 \text{ VA}/200 \text{ V} = 50 \text{ A}$ when operated under rated conditions. The volt-ampere rating of a piece of equipment is equal to the wattage rating only when the F_p is 1. It is therefore a maximum power dissipation rating. This condition exists only when the total impedance of a system $Z \angle \theta$ is such that $\theta = 0^\circ$.

The exact current demand of a device, when used under normal operating conditions, could be determined if the wattage rating and power factor were given instead of the volt-ampere rating. However, the power factor is sometimes not available, or it may vary with the load.

^{*}Prior to 1968, the symbol for apparent power was the more descriptive P_a .

The reason for rating some electrical equipment in kilovolt-amperes rather than in kilowatts can be described using the configuration of Fig. 19.5. The load has an apparent power rating of 10 kVA and a current rating of 50 A at the applied voltage, 200 V. As indicated, the current demand of 70 A is above the rated value and could damage the load element, yet the reading on the wattmeter is relatively low since the load is highly reactive. In other words, the wattmeter reading is an indication of the watts dissipated and may not reflect the magnitude of the current drawn. Theoretically, if the load were purely reactive, the wattmeter reading would be zero even if the load was being damaged by a high current level.

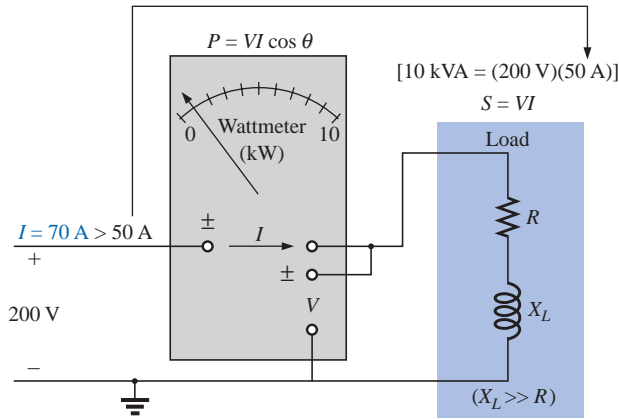

FIG. 19.5

Demonstrating the reason for rating a load in kVA rather than kW.

19.4 INDUCTIVE CIRCUIT AND REACTIVE POWER

For a purely inductive circuit (such as that in Fig. 19.6), v leads i by 90° , as shown in Fig. 19.7. Therefore, in Eq. (19.1), $\theta = 90^\circ$. Substituting $\theta = 90^\circ$ into Eq. (19.1) yields

$$p_L = VI \cos(90^\circ)(1 - \cos 2\omega t) + VI \sin(90^\circ)(\sin 2\omega t) \\ = 0 + VI \sin 2\omega t$$

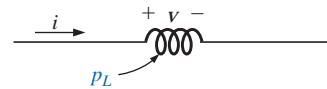

FIG. 19.6

Defining the power level for a purely inductive load.

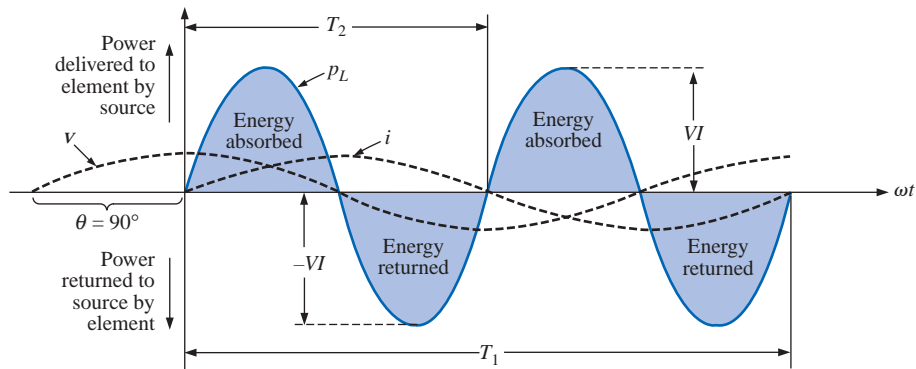

FIG. 19.7

The power curve for a purely inductive load.

or

$$p_L = VI \sin 2\omega t \quad (19.11)$$

where $VI \sin 2\omega t$ is a sine wave with twice the frequency of either input quantity (v or i) and a peak value of VI . Note the absence of an average or constant term in the equation.

Plotting the waveform for p_L (Fig. 19.7), we obtain

T_1 = period of either input quantity

T_2 = period of p_L curve

Note that over one full cycle of p_L (T_2), the area above the horizontal axis in Fig. 19.7 is exactly equal to that below the axis. This indicates that over a full cycle of p_L , the power delivered by the source to the inductor is exactly equal to that returned to the source by the inductor.

The net flow of power to the pure (ideal) inductor is zero over a full cycle, and no energy is lost in the transaction.

The power absorbed or returned by the inductor at any instant of time t_1 can be found simply by substituting t_1 into Eq. (19.11). The peak value of the curve VI is defined as the **reactive power** associated with a pure inductor.

In general, the reactive power associated with any circuit is defined to be $VI \sin \theta$, a factor appearing in the second term of Eq. (19.1). Note that it is the peak value of that term of the total power equation that produces no net transfer of energy. The symbol for reactive power is Q , and its unit of measure is the *volt-ampere reactive* (VAR).^{*} The Q is derived from the quadrature (90°) relationship between the various powers, to be discussed in detail in a later section. Therefore,

$$Q = VI \sin \theta \quad (\text{volt-ampere reactive, VAR}) \quad (19.12)$$

where θ is the phase angle between V and I .

For the inductor,

$$Q_L = VI \quad (\text{VAR}) \quad (19.13)$$

or, since $V = IX_L$ or $I = V/X_L$,

$$Q_L = I^2 X_L \quad (\text{VAR}) \quad (19.14)$$

or

$$Q_L = \frac{V^2}{X_L} \quad (\text{VAR}) \quad (19.15)$$

The apparent power associated with an inductor is $S = VI$, and the average power is $P = 0$, as noted in Fig. 19.7. The power factor is therefore

$$F_p = \cos \theta = \frac{P}{S} = \frac{0}{VI} = 0$$

^{*}Prior to 1968, the symbol for reactive power was the more descriptive P_q .

If the average power is zero, and the energy supplied is returned within one cycle, why is reactive power of any significance? The reason is not obvious but can be explained using the curve of Fig. 19.7. At every instant of time along the power curve that the curve is above the axis (positive), energy must be supplied to the inductor, even though it will be returned during the negative portion of the cycle. This power requirement during the positive portion of the cycle requires that the generating plant provide this energy during that interval. Therefore, the effect of reactive elements such as the inductor can be to raise the power requirement of the generating plant, even though the reactive power is not dissipated but simply “borrowed.” The increased power demand during these intervals is a cost factor that must be passed on to the industrial consumer. In fact, most larger users of electrical energy pay for the apparent power demand rather than the watts dissipated since the volt-amperes used are sensitive to the reactive power requirement (see Section 19.6). In other words, the closer the power factor of an industrial outfit is to 1, the more efficient is the plant’s operation since it is limiting its use of “borrowed” power.

The energy stored by the inductor during the positive portion of the cycle (Fig. 19.7) is equal to that returned during the negative portion and can be determined using the following equation:

$$W = Pt$$

where P is the average value for the interval and t is the associated interval of time.

Recall from Chapter 14 that the average value of the positive portion of a sinusoid equals $2(\text{peak value}/\pi)$ and $t = T_2/2$. Therefore,

$$W_L = \left(\frac{2VI}{\pi}\right) \times \left(\frac{T_2}{2}\right)$$

and

$$W_L = \frac{VIT_2}{\pi} \quad \text{(J)} \quad \textbf{(19.16)}$$

or, since $T_2 = 1/f_2$, where f_2 is the frequency of the p_L curve, we have

$$W_L = \frac{VI}{\pi f_2} \quad \text{(J)} \quad \textbf{(19.17)}$$

Since the frequency f_2 of the power curve is twice that of the input quantity, if we substitute the frequency f_1 of the input voltage or current, Equation (19.17) becomes

$$W_L = \frac{VI}{\pi(2f_1)} = \frac{VI}{\omega_1}$$

However,

$$V = IX_L = I\omega_1 L$$

so that

$$W_L = \frac{(I\omega_1 L)I}{\omega_1}$$

and

$$W_L = LI^2 \quad \text{(J)} \quad \textbf{(19.18)}$$

providing an equation for the energy stored or released by the inductor in one half-cycle of the applied voltage in terms of the inductance and rms value of the current squared.

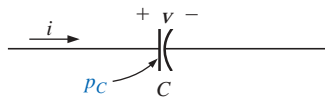

FIG. 19.8

Defining the power level for a purely capacitive load.

19.5 CAPACITIVE CIRCUIT

For a purely capacitive circuit (such as that in Fig. 19.8), i leads v by 90° , as shown in Fig. 19.9. Therefore, in Eq. (19.1), $\theta = -90^\circ$. Substituting $\theta = -90^\circ$ into Eq. (19.1), we obtain

$$\begin{aligned} p_C &= VI \cos(-90^\circ)(1 - \cos 2\omega t) + VI \sin(-90^\circ)(\sin 2\omega t) \\ &= 0 - VI \sin 2\omega t \end{aligned}$$

or

$$p_C = -VI \sin 2\omega t \quad (19.19)$$

where $-VI \sin 2\omega t$ is a negative sine wave with twice the frequency of either input (v or i) and a peak value of VI . Again, note the absence of an average or constant term.

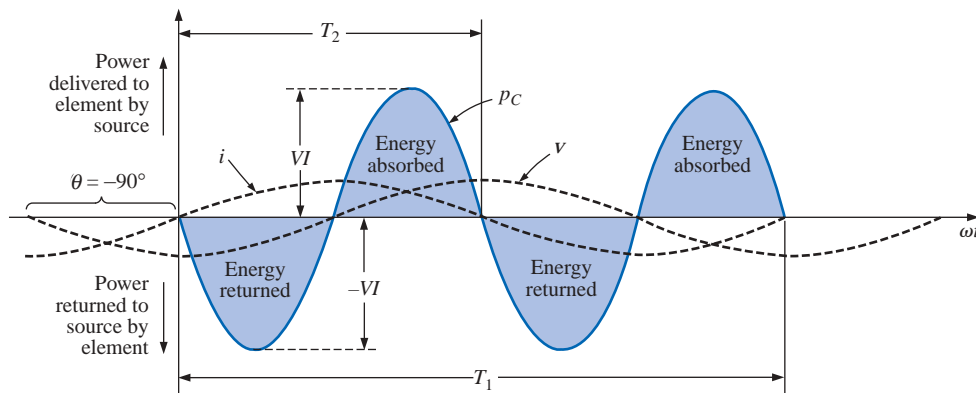

FIG. 19.9

The power curve for a purely capacitive load.

Plotting the waveform for p_C (Fig. 19.9) gives us

$$T_1 = \text{period of either input quantity}$$

$$T_2 = \text{period of } p_C \text{ curve}$$

Note that the same situation exists here for the p_C curve as existed for the p_L curve. The power delivered by the source to the capacitor is exactly equal to that returned to the source by the capacitor over one full cycle.

The net flow of power to the pure (ideal) capacitor is zero over a full cycle,

and no energy is lost in the transaction. The power absorbed or returned by the capacitor at any instant of time t_1 can be found by substituting t_1 into Eq. (19.19).

The reactive power associated with the capacitor is equal to the peak value of the p_C curve, as follows:

$$Q_C = VI \quad (\text{VAR}) \quad (19.20)$$

But, since $V = IX_C$ and $I = V/X_C$, the reactive power to the capacitor can also be written

$$Q_C = I^2 X_C \quad (\text{VAR}) \quad (19.21)$$

and
$$Q_C = \frac{V^2}{X_C} \quad (\text{VAR}) \quad (19.22)$$

The apparent power associated with the capacitor is

$$S = VI \quad (\text{VA}) \quad (19.23)$$

and the average power is $P = 0$, as noted from Eq. (19.19) or Fig. 19.9. The power factor is, therefore,

$$F_p = \cos \theta = \frac{P}{S} = \frac{0}{VI} = 0$$

The energy stored by the capacitor during the positive portion of the cycle (Fig. 19.9) is equal to that returned during the negative portion and can be determined using the equation $W = Pt$.

Proceeding in a manner similar to that used for the inductor, we can show that

$$W_C = \frac{VIT_2}{\pi} \quad (\text{J}) \quad (19.24)$$

or, since $T_2 = 1/f_2$, where f_2 is the frequency of the p_C curve,

$$W_C = \frac{VI}{\pi f_2} \quad (\text{J}) \quad (19.25)$$

In terms of the frequency f_1 of the input quantities v and i ,

$$W_C = \frac{VI}{\pi(2f_1)} = \frac{VI}{\omega_1} = \frac{V(V\omega_1 C)}{\omega_1}$$

and
$$W_C = CV^2 \quad (\text{J}) \quad (19.26)$$

providing an equation for the energy stored or released by the capacitor in one half-cycle of the applied voltage in terms of the capacitance and rms value of the voltage squared.

19.6 THE POWER TRIANGLE

The three quantities **average power**, **apparent power**, and **reactive power** can be related in the vector domain by

$$\mathbf{S} = \mathbf{P} + \mathbf{Q} \quad (19.27)$$

with

$$\mathbf{P} = P \angle 0^\circ \quad \mathbf{Q}_L = Q_L \angle 90^\circ \quad \mathbf{Q}_C = Q_C \angle -90^\circ$$

For an inductive load, the *phasor power* \mathbf{S} , as it is often called, is defined by

$$\mathbf{S} = P + jQ_L$$

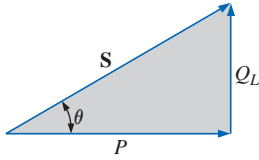

FIG. 19.10
Power diagram for inductive loads.

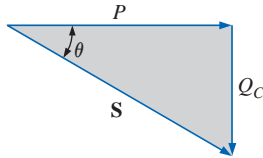

FIG. 19.11
Power diagram for capacitive loads.

as shown in Fig. 19.10.

The 90° shift in Q_L from P is the source of another term for reactive power: *quadrature power*.

For a capacitive load, the phasor power \mathbf{S} is defined by

$$\mathbf{S} = P - j Q_C$$

as shown in Fig. 19.11.

If a network has both capacitive and inductive elements, the reactive component of the power triangle will be determined by the *difference* between the reactive power delivered to each. If $Q_L > Q_C$, the resultant power triangle will be similar to Fig. 19.10. If $Q_C > Q_L$, the resultant power triangle will be similar to Fig. 19.11.

That the total reactive power is the difference between the reactive powers of the inductive and capacitive elements can be demonstrated by considering Eqs. (19.11) and (19.19). Using these equations, the reactive power delivered to each reactive element has been plotted for a series L - C circuit on the same set of axes in Fig. 19.12. The reactive elements were chosen such that $X_L > X_C$. Note that the power curve for each is exactly 180° out of phase. The curve for the resultant reactive power is therefore determined by the algebraic resultant of the two at each instant of time. Since the reactive power is defined as the peak value, the reactive component of the power triangle is as indicated in the figure: $I^2(X_L - X_C)$.

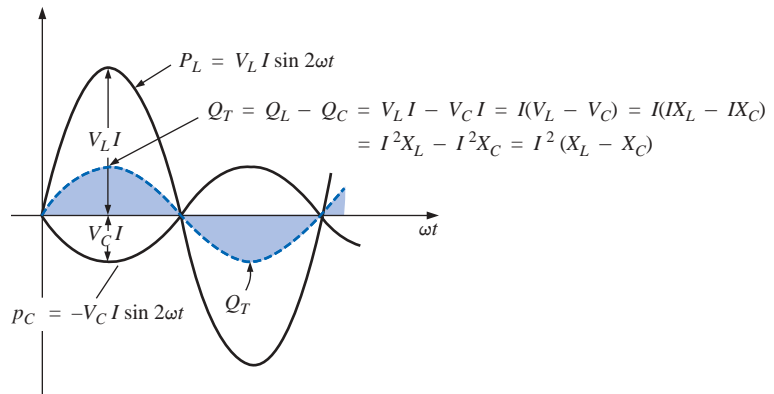

FIG. 19.12

Demonstrating why the net reactive power is the difference between that delivered to inductive and capacitive elements.

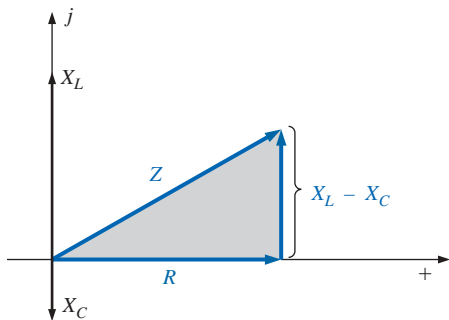

FIG. 19.13
Impedance diagram for a series R - L - C circuit.

An additional verification can be derived by first considering the impedance diagram of a series R - L - C circuit (Fig. 19.13). If we multiply each radius vector by the current squared (I^2), we obtain the results shown in Fig. 19.14, which is the power triangle for a predominantly inductive circuit.

Since the reactive power and average power are always angled 90° to each other, the three powers are related by the Pythagorean theorem; that is,

$$S^2 = P^2 + Q^2$$

(19.28)

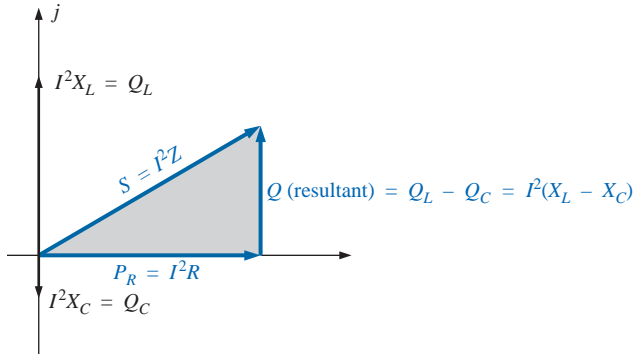

FIG. 19.14

The result of multiplying each vector of Fig. 19.13 by I^2 for a series R-L-C circuit.

Therefore, the third power can always be found if the other two are known.

It is particularly interesting that the equation

$$\boxed{S = VI^*} \quad (19.29)$$

will provide the vector form of the apparent power of a system. Here, V is the voltage across the system, and I^* is the complex conjugate of the current.

Consider, for example, the simple R-L circuit of Fig. 19.15, where

$$I = \frac{V}{Z_T} = \frac{10 \text{ V } \angle 0^\circ}{3 \Omega + j 4 \Omega} = \frac{10 \text{ V } \angle 0^\circ}{5 \Omega \angle 53.13^\circ} = 2 \text{ A } \angle -53.13^\circ$$

The real power (the term *real* being derived from the positive real axis of the complex plane) is

$$P = I^2 R = (2 \text{ A})^2 (3 \Omega) = 12 \text{ W}$$

and the reactive power is

$$Q_L = I^2 X_L = (2 \text{ A})^2 (4 \Omega) = 16 \text{ VAR (L)}$$

with $S = P + j Q_L = 12 \text{ W} + j 16 \text{ VAR (L)} = 20 \text{ VA } \angle 53.13^\circ$

as shown in Fig. 19.16. Applying Eq. (19.29) yields

$$S = VI^* = (10 \text{ V } \angle 0^\circ)(2 \text{ A } \angle +53.13^\circ) = 20 \text{ VA } \angle 53.13^\circ$$

as obtained above.

The angle θ associated with S and appearing in Figs. 19.10, 19.11, and 19.16 is the power-factor angle of the network. Since

$$P = VI \cos \theta$$

or

$$P = S \cos \theta$$

then

$$\boxed{F_p = \cos \theta = \frac{P}{S}} \quad (19.30)$$

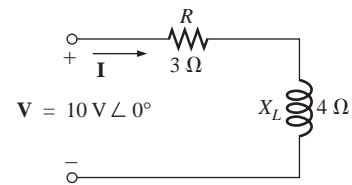

FIG. 19.15

Demonstrating the validity of Eq. (19.29).

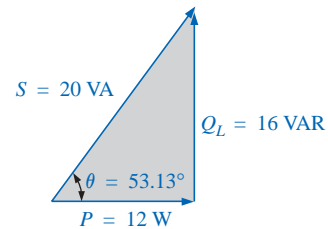

FIG. 19.16

The power triangle for the circuit of Fig. 19.15.

19.7 THE TOTAL P , Q , AND S

The total number of watts, volt-amperes reactive, and volt-amperes, and the power factor of any system can be found using the following procedure:

1. Find the real power and reactive power for each branch of the circuit.
2. The total real power of the system (P_T) is then the sum of the average power delivered to each branch.
3. The total reactive power (Q_T) is the difference between the reactive power of the inductive loads and that of the capacitive loads.
4. The total apparent power is $S_T = \sqrt{P_T^2 + Q_T^2}$.
5. The total power factor is P_T/S_T .

There are two important points in the above tabulation. First, the total apparent power must be determined from the total average and reactive powers and *cannot* be determined from the apparent powers of each branch. Second, and more important, it is *not necessary* to consider the series-parallel arrangement of branches. In other words, the total real, reactive, or apparent power is independent of whether the loads are in series, parallel, or series-parallel. The following examples will demonstrate the relative ease with which all of the quantities of interest can be found.

EXAMPLE 19.1 Find the total number of watts, volt-amperes reactive, and volt-amperes, and the power factor F_p of the network in Fig. 19.17. Draw the power triangle and find the current in phasor form.

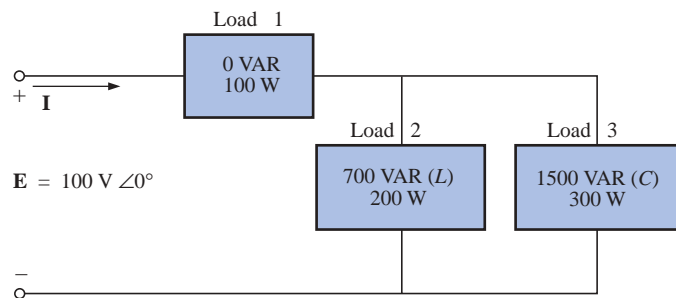

FIG. 19.17

Example 19.1.

Solution: Construct a table such as shown in Table 19.1.

TABLE 19.1

Load	W	VAR	VA
1	100	0	100
2	200	700 (L)	$\sqrt{(200)^2 + (700)^2} = 728.0$
3	300	1500 (C)	$\sqrt{(300)^2 + (1500)^2} = 1529.71$
	$P_T = 600$	$Q_T = 800 (C)$	$S_T = \sqrt{(600)^2 + (800)^2} = 1000$
	Total power dissipated	Resultant reactive power of network	(Note that $S_T \neq$ sum of each branch: $1000 \neq 100 + 728 + 1529.71$)

Thus,

$$F_p = \frac{P_T}{S_T} = \frac{600 \text{ W}}{1000 \text{ VA}} = \mathbf{0.6 \text{ leading (C)}}$$

The power triangle is shown in Fig. 19.18.

Since $S_T = VI = 1000 \text{ VA}$, $I = 1000 \text{ VA}/100 \text{ V} = 10 \text{ A}$; and since θ of $\cos \theta = F_p$ is the angle between the input voltage and current:

$$\mathbf{I = 10 \text{ A } \angle +53.13^\circ}$$

The plus sign is associated with the phase angle since the circuit is predominantly capacitive.

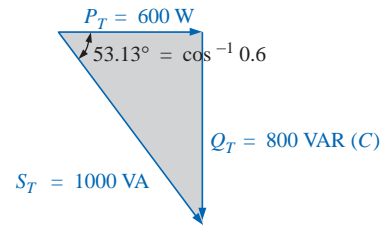

FIG. 19.18
Power triangle for Example 19.1.

EXAMPLE 19.2

- a. Find the total number of watts, volt-amperes reactive, and volt-amperes, and the power factor F_p for the network of Fig. 19.19.

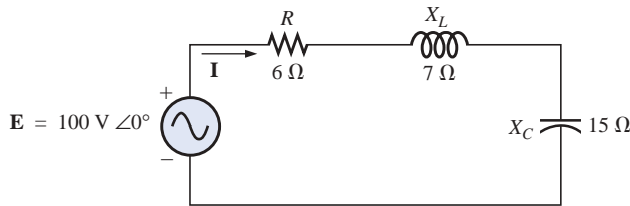

FIG. 19.19
Example 19.2.

- b. Sketch the power triangle.
- c. Find the energy dissipated by the resistor over one full cycle of the input voltage if the frequency of the input quantities is 60 Hz.
- d. Find the energy stored in, or returned by, the capacitor or inductor over one half-cycle of the power curve for each if the frequency of the input quantities is 60 Hz.

Solutions:

$$\begin{aligned} \text{a. } \mathbf{I} &= \frac{\mathbf{E}}{\mathbf{Z}_T} = \frac{100 \text{ V } \angle 0^\circ}{6 \Omega + j7 \Omega - j15 \Omega} = \frac{100 \text{ V } \angle 0^\circ}{10 \Omega \angle -53.13^\circ} \\ &= 10 \text{ A } \angle 53.13^\circ \end{aligned}$$

$$\mathbf{V}_R = (10 \text{ A } \angle 53.13^\circ)(6 \Omega \angle 0^\circ) = 60 \text{ V } \angle 53.13^\circ$$

$$\mathbf{V}_L = (10 \text{ A } \angle 53.13^\circ)(7 \Omega \angle 90^\circ) = 70 \text{ V } \angle 143.13^\circ$$

$$\mathbf{V}_C = (10 \text{ A } \angle 53.13^\circ)(15 \Omega \angle -90^\circ) = 150 \text{ V } \angle -36.87^\circ$$

$$P_T = EI \cos \theta = (100 \text{ V})(10 \text{ A}) \cos 53.13^\circ = \mathbf{600 \text{ W}}$$

$$= I^2 R = (10 \text{ A})^2(6 \Omega) = \mathbf{600 \text{ W}}$$

$$= \frac{V_R^2}{R} = \frac{(60 \text{ V})^2}{6} = \mathbf{600 \text{ W}}$$

$$S_T = EI = (100 \text{ V})(10 \text{ A}) = \mathbf{1000 \text{ VA}}$$

$$= I^2 Z_T = (10 \text{ A})^2(10 \Omega) = \mathbf{1000 \text{ VA}}$$

$$= \frac{E^2}{Z_T} = \frac{(100 \text{ V})^2}{10 \Omega} = \mathbf{1000 \text{ VA}}$$

$$Q_T = EI \sin \theta = (100 \text{ V})(10 \text{ A}) \sin 53.13^\circ = \mathbf{800 \text{ VAR}}$$

$$= Q_C - Q_L$$

$$= I^2(X_C - X_L) = (10 \text{ A})^2(15 \Omega - 7 \Omega) = \mathbf{800 \text{ VAR}}$$

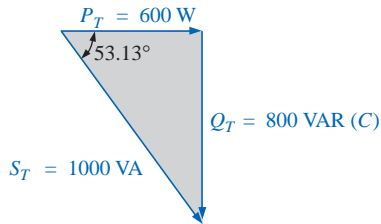

FIG. 19.20

Power triangle for Example 19.2.

$$Q_T = \frac{V_C^2}{X_C} - \frac{V_L^2}{X_L} = \frac{(150 \text{ V})^2}{15 \Omega} - \frac{(70 \text{ V})^2}{7 \Omega}$$

$$= 1500 \text{ VAR} - 700 \text{ VAR} = \mathbf{800 \text{ VAR}}$$

$$F_p = \frac{P_T}{S_T} = \frac{600 \text{ W}}{1000 \text{ VA}} = \mathbf{0.6 \text{ leading (C)}}$$

b. The power triangle is as shown in Fig. 19.20.

$$c. W_R = \frac{V_R I}{f_1} = \frac{(60 \text{ V})(10 \text{ A})}{60 \text{ Hz}} = \mathbf{10 \text{ J}}$$

$$d. W_L = \frac{V_L I}{\omega_1} = \frac{(70 \text{ V})(10 \text{ A})}{(2\pi)(60 \text{ Hz})} = \frac{700 \text{ J}}{377} = \mathbf{1.86 \text{ J}}$$

$$W_C = \frac{V_C I}{\omega_1} = \frac{(150 \text{ V})(10 \text{ A})}{377 \text{ rad/s}} = \frac{1500 \text{ J}}{377} = \mathbf{3.98 \text{ J}}$$

EXAMPLE 19.3 For the system of Fig. 19.21,

FIG. 19.21

Example 19.3.

- Find the average power, apparent power, reactive power, and F_p for each branch.
- Find the total number of watts, volt-amperes reactive, and volt-amperes, and the power factor of the system. Sketch the power triangle.
- Find the source current I .

Solutions:a. *Bulbs:*

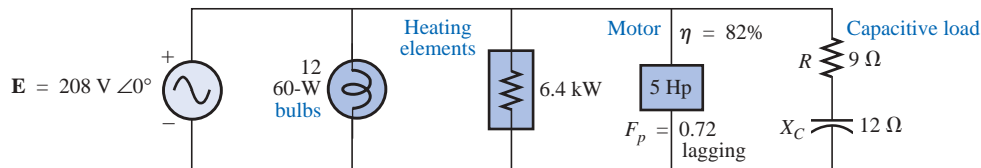
Total dissipation of applied power

$$P_1 = 12(60 \text{ W}) = \mathbf{720 \text{ W}}$$

$$Q_1 = \mathbf{0 \text{ VAR}}$$

$$S_1 = P_1 = \mathbf{720 \text{ VA}}$$

$$F_{p1} = \mathbf{1}$$

Heating elements:

Total dissipation of applied power

$$P_2 = \mathbf{6.4 \text{ kW}}$$

$$Q_2 = \mathbf{0 \text{ VAR}}$$

$$S_2 = P_2 = \mathbf{6.4 \text{ kVA}}$$

$$F_{p2} = \mathbf{1}$$

Motor:

$$\eta = \frac{P_o}{P_i} \rightarrow P_i = \frac{P_o}{\eta} = \frac{5(746 \text{ W})}{0.82} = \mathbf{4548.78 \text{ W}} = P_3$$

$F_p = \mathbf{0.72 \text{ lagging}}$

$$P_3 = S_3 \cos \theta \rightarrow S_3 = \frac{P_3}{\cos \theta} = \frac{4548.78 \text{ W}}{0.72} = \mathbf{6317.75 \text{ VA}}$$

Also, $\theta = \cos^{-1} 0.72 = 43.95^\circ$, so that

$$\begin{aligned} Q_3 &= S_3 \sin \theta = (6317.75 \text{ VA})(\sin 43.95^\circ) \\ &= (6317.75 \text{ VA})(0.694) = \mathbf{4384.71 \text{ VAR (L)}} \end{aligned}$$

Capacitive load:

$$\mathbf{I} = \frac{\mathbf{E}}{\mathbf{Z}} = \frac{208 \text{ V} \angle 0^\circ}{9 \Omega - j 12 \Omega} = \frac{208 \text{ V} \angle 0^\circ}{15 \Omega \angle -53.13^\circ} = 13.87 \text{ A} \angle 53.13^\circ$$

$$P_4 = I^2 R = (13.87 \text{ A})^2 \cdot 9 \Omega = \mathbf{1731.39 \text{ W}}$$

$$Q_4 = I^2 X_C = (13.87 \text{ A})^2 \cdot 12 \Omega = \mathbf{2308.52 \text{ VAR (C)}}$$

$$\begin{aligned} S_4 &= \sqrt{P_4^2 + Q_4^2} = \sqrt{(1731.39 \text{ W})^2 + (2308.52 \text{ VAR})^2} \\ &= \mathbf{2885.65 \text{ VA}} \end{aligned}$$

$$F_p = \frac{P_4}{S_4} = \frac{1731.39 \text{ W}}{2885.65 \text{ VA}} = \mathbf{0.6 \text{ leading}}$$

$$\begin{aligned} \text{b. } P_T &= P_1 + P_2 + P_3 + P_4 \\ &= 720 \text{ W} + 6400 \text{ W} + 4548.78 \text{ W} + 1731.39 \text{ W} \\ &= \mathbf{13,400.17 \text{ W}} \end{aligned}$$

$$\begin{aligned} Q_T &= \pm Q_1 \pm Q_2 \pm Q_3 \pm Q_4 \\ &= 0 + 0 + 4384.71 \text{ VAR (L)} - 2308.52 \text{ VAR (C)} \\ &= \mathbf{2076.19 \text{ VAR (L)}} \end{aligned}$$

$$\begin{aligned} S_T &= \sqrt{P_T^2 + Q_T^2} = \sqrt{(13,400.17 \text{ W})^2 + (2076.19 \text{ VAR})^2} \\ &= 13,560.06 \text{ VA} \end{aligned}$$

$$F_p = \frac{P_T}{S_T} = \frac{13.4 \text{ kW}}{13,560.06 \text{ VA}} = \mathbf{0.988 \text{ lagging}}$$

$$\theta = \cos^{-1} 0.988 = 8.89^\circ$$

Note Fig. 19.22.

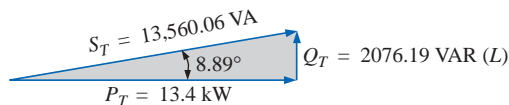

FIG. 19.22
Power triangle for Example 19.3.

$$\text{c. } S_T = EI \rightarrow I = \frac{S_T}{E} = \frac{13,559.89 \text{ VA}}{208 \text{ V}} = 65.19 \text{ A}$$

Lagging power factor: **E** leads **I** by 8.89° , and

$$\mathbf{I} = \mathbf{65.19 \text{ A} \angle -8.89^\circ}$$

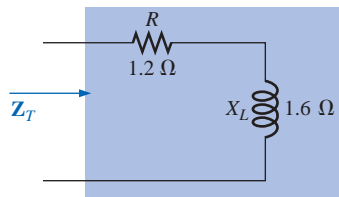

FIG. 19.23
Example 19.4.

EXAMPLE 19.4 An electrical device is rated 5 kVA, 100 V at a 0.6 power-factor lag. What is the impedance of the device in rectangular coordinates?

Solution:

$$S = EI = 5000 \text{ VA}$$

$$\text{Therefore, } I = \frac{5000 \text{ VA}}{100 \text{ V}} = 50 \text{ A}$$

For $F_p = 0.6$, we have

$$\theta = \cos^{-1} 0.6 = 53.13^\circ$$

Since the power factor is lagging, the circuit is predominantly inductive, and \mathbf{I} lags \mathbf{E} . Or, for $\mathbf{E} = 100 \text{ V} \angle 0^\circ$,

$$\mathbf{I} = 50 \text{ A} \angle -53.13^\circ$$

However,

$$\mathbf{Z}_T = \frac{\mathbf{E}}{\mathbf{I}} = \frac{100 \text{ V} \angle 0^\circ}{50 \text{ A} \angle -53.13^\circ} = 2 \Omega \angle 53.13^\circ = \mathbf{1.2 \Omega + j1.6 \Omega}$$

which is the impedance of the circuit of Fig. 19.23.

19.8 POWER-FACTOR CORRECTION

The design of any power transmission system is very sensitive to the magnitude of the current in the lines as determined by the applied loads. Increased currents result in increased power losses (by a squared factor since $P = I^2R$) in the transmission lines due to the resistance of the lines. Heavier currents also require larger conductors, increasing the amount of copper needed for the system, and, quite obviously, they require increased generating capacities by the utility company.

Every effort must therefore be made to keep current levels at a minimum. Since the line voltage of a transmission system is fixed, the apparent power is directly related to the current level. In turn, the smaller the net apparent power, the smaller the current drawn from the supply. Minimum current is therefore drawn from a supply when $S = P$ and $Q_T = 0$. Note the effect of decreasing levels of Q_T on the length (and magnitude) of S in Fig. 19.24 for the same real power. Note also that the power-factor angle approaches zero degrees and F_p approaches 1, revealing that the network is appearing more and more resistive at the input terminals.

The process of introducing reactive elements to bring the power factor closer to unity is called **power-factor correction**. Since most loads are inductive, the process normally involves introducing elements with capacitive terminal characteristics having the sole purpose of improving the power factor.

In Fig. 19.25(a), for instance, an inductive load is drawing a current I_L that has a real and an imaginary component. In Fig. 19.25(b), a capacitive load was added in parallel with the original load to raise the power factor of the total system to the unity power-factor level. Note that by placing all the elements in parallel, the load still receives the same terminal voltage and draws the same current I_L . In other words, the load is unaware of and unconcerned about whether it is hooked up as shown in Fig. 19.25(a) or Fig. 19.25(b).

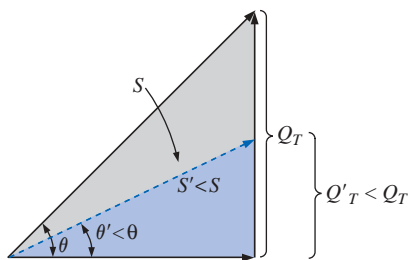

FIG. 19.24
Demonstrating the impact of power-factor correction on the power triangle of a network.

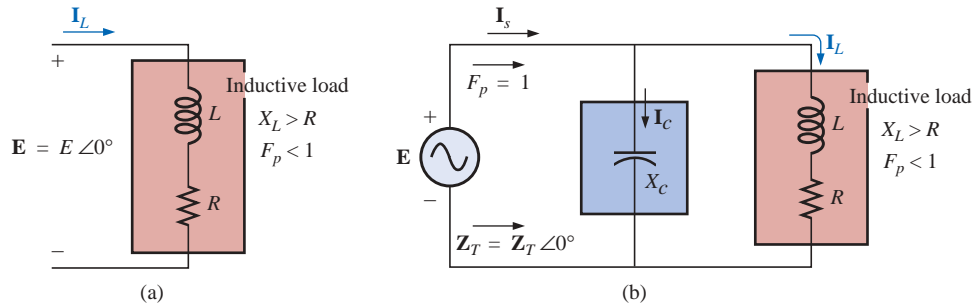

FIG. 19.25

Demonstrating the impact of a capacitive element on the power factor of a network.

Solving for the source current in Fig. 19.25(b):

$$\begin{aligned} \mathbf{I}_s &= \mathbf{I}_C + \mathbf{I}_L \\ &= j I_C(I_{\text{mag}}) + I_L(R_e) + j I_L(I_{\text{mag}}) \\ &= I_L(R_e) + j [I_L(I_{\text{mag}}) + I_C(I_{\text{mag}})] \end{aligned}$$

If X_C is chosen such that $I_C(I_{\text{mag}}) = I_L(I_{\text{mag}})$, then

$$\mathbf{I}_s = I_L(R_e) + j(0) = I_L(R_e) \angle 0^\circ$$

The result is a source current whose magnitude is simply equal to the real part of the load current, which can be considerably less than the magnitude of the load current of Fig. 19.25(a). In addition, since the phase angle associated with both the applied voltage and the source current is the same, the system appears “resistive” at the input terminals, and all of the power supplied is absorbed, creating maximum efficiency for a generating utility.

EXAMPLE 19.5 A 5-hp motor with a 0.6 lagging power factor and an efficiency of 92% is connected to a 208-V, 60-Hz supply.

- Establish the power triangle for the load.
- Determine the power-factor capacitor that must be placed in parallel with the load to raise the power factor to unity.
- Determine the change in supply current from the uncompensated to the compensated system.
- Find the network equivalent of the above, and verify the conclusions.

Solutions:

a. Since $1 \text{ hp} = 746 \text{ W}$,

$$P_o = 5 \text{ hp} = 5(746 \text{ W}) = 3730 \text{ W}$$

and P_i (drawn from the line) $= \frac{P_o}{\eta} = \frac{3730 \text{ W}}{0.92} = 4054.35 \text{ W}$

Also, $F_p = \cos \theta = 0.6$

and $\theta = \cos^{-1} 0.6 = 53.13^\circ$

Applying $\tan \theta = \frac{Q_L}{P_i}$

we obtain $Q_L = P_i \tan \theta = (4054.35 \text{ W}) \tan 53.13^\circ = 5405.8 \text{ VAR (L)}$

and

$$\begin{aligned} S &= \sqrt{P_i^2 + Q_L^2} = \sqrt{(4054.35 \text{ W})^2 + (5405.8 \text{ VAR})^2} \\ &= 6757.25 \text{ VA} \end{aligned}$$

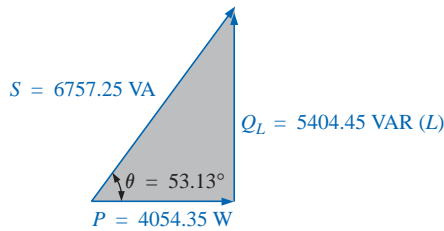

FIG. 19.26
Initial power triangle for the load of
Example 19.5.

The power triangle appears in Fig. 19.26.

- b. A net unity power-factor level is established by introducing a capacitive reactive power level of 5405.8 VAR to balance Q_L . Since

$$Q_C = \frac{V^2}{X_C}$$

then
$$X_C = \frac{V^2}{Q_C} = \frac{(208 \text{ V})^2}{5405.8 \text{ VAR (C)}} = 8 \Omega$$

and
$$C = \frac{1}{2\pi f X_C} = \frac{1}{(2\pi)(60 \text{ Hz})(8 \Omega)} = 331.6 \mu\text{F}$$

- c. At $0.6F_p$,

$$S = VI = 6757.25 \text{ VA}$$

and
$$I = \frac{S}{V} = \frac{6757.25 \text{ VA}}{208 \text{ V}} = 32.49 \text{ A}$$

At unity F_p ,

$$S = VI = 4054.35 \text{ VA}$$

and
$$I = \frac{S}{V} = \frac{4054.35 \text{ VA}}{208 \text{ V}} = 19.49 \text{ A}$$

producing a 40% reduction in supply current.

- d. For the motor, the angle by which the applied voltage leads the current is

$$\theta = \cos^{-1} 0.6 = 53.13^\circ$$

and $P = EI_m \cos \theta = 4054.35 \text{ W}$, from above, so that

$$I_m = \frac{P}{E \cos \theta} = \frac{4054.35 \text{ W}}{(208 \text{ V})(0.6)} = 32.49 \text{ A} \quad (\text{as above})$$

resulting in

$$\mathbf{I}_m = 32.49 \text{ A} \angle -53.13^\circ$$

Therefore,

$$\begin{aligned} \mathbf{Z}_m &= \frac{\mathbf{E}}{\mathbf{I}_m} = \frac{208 \text{ V} \angle 0^\circ}{32.49 \text{ A} \angle -53.13^\circ} = 6.4 \Omega \angle 53.13^\circ \\ &= 3.84 \Omega + j 5.12 \Omega \end{aligned}$$

as shown in Fig. 19.27(a).

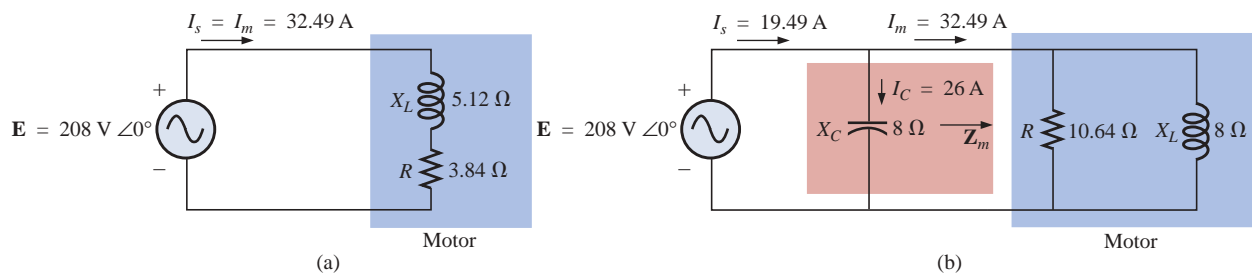

FIG. 19.27

Demonstrating the impact of power-factor corrections on the source current.

The equivalent parallel load is determined from

$$\begin{aligned} \mathbf{Y} &= \frac{1}{\mathbf{Z}} = \frac{1}{6.4 \Omega \angle 53.13^\circ} \\ &= 0.156 \text{ S} \angle -53.13^\circ = 0.094 \text{ S} - j 0.125 \text{ S} \\ &= \frac{1}{10.64 \Omega} + \frac{1}{j 8 \Omega} \end{aligned}$$

as shown in Fig. 19.27(b).

It is now clear that the effect of the 8-Ω inductive reactance can be compensated for by a parallel capacitive reactance of 8 Ω using a power-factor correction capacitor of 332 μF.

Since

$$\mathbf{Y}_T = \frac{1}{-j X_C} + \frac{1}{R} + \frac{1}{+j X_L} = \frac{1}{R}$$

$$I_s = E Y_T = E \left(\frac{1}{R} \right) = (208 \text{ V}) \left(\frac{1}{10.64 \Omega} \right) = \mathbf{19.54 \text{ A}} \quad \text{as above}$$

In addition, the magnitude of the capacitive current can be determined as follows:

$$I_C = \frac{E}{X_C} = \frac{208 \text{ V}}{8 \Omega} = \mathbf{26 \text{ A}}$$

EXAMPLE 19.6

- A small industrial plant has a 10-kW heating load and a 20-kVA inductive load due to a bank of induction motors. The heating elements are considered purely resistive ($F_p = 1$), and the induction motors have a lagging power factor of 0.7. If the supply is 1000 V at 60 Hz, determine the capacitive element required to raise the power factor to 0.95.
- Compare the levels of current drawn from the supply.

Solutions:

- For the induction motors,

$$\begin{aligned} S &= VI = 20 \text{ kVA} \\ P &= S \cos \theta = (20 \times 10^3 \text{ VA})(0.7) = 14 \times 10^3 \text{ W} \\ \theta &= \cos^{-1} 0.7 \cong 45.6^\circ \end{aligned}$$

and

$$Q_L = VI \sin \theta = (20 \times 10^3 \text{ VA})(0.714) = 14.28 \times 10^3 \text{ VAR (L)}$$

The power triangle for the total system appears in Fig. 19.28.

Note the addition of real powers and the resulting S_T :

$$S_T = \sqrt{(24 \text{ kW})^2 + (14.28 \text{ kVAR})^2} = 27.93 \text{ kVA}$$

with
$$I_T = \frac{S_T}{E} = \frac{27.93 \text{ kVA}}{1000 \text{ V}} = \mathbf{27.93 \text{ A}}$$

The desired power factor of 0.95 results in an angle between S and P of

$$\theta = \cos^{-1} 0.95 = 18.19^\circ$$

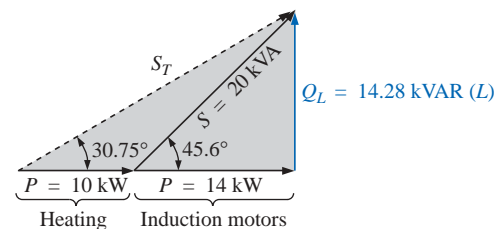

FIG. 19.28
Initial power triangle for the load of Example 19.6.

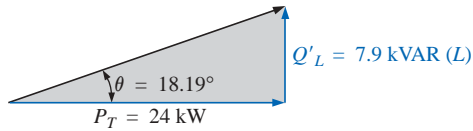

FIG. 19.29

Power triangle for the load of Example 19.6 after raising the power factor to 0.95.

changing the power triangle to that of Fig. 19.29:

$$\begin{aligned} \text{with } \tan \theta &= \frac{Q'_L}{P_T} \rightarrow Q'_L = P_T \tan \theta = (24 \times 10^3 \text{ W})(\tan 18.19^\circ) \\ &= (24 \times 10^3 \text{ W})(0.329) = 7.9 \text{ kVAR (L)} \end{aligned}$$

The inductive reactive power must therefore be reduced by

$$Q_L - Q'_L = 14.28 \text{ kVAR (L)} - 7.9 \text{ kVAR (L)} = 6.38 \text{ kVAR (L)}$$

Therefore, $Q_C = 6.38 \text{ kVAR}$, and using

$$Q_C = \frac{E^2}{X_C}$$

we obtain

$$X_C = \frac{E^2}{Q_C} = \frac{(10^3 \text{ V})^2}{6.38 \times 10^3 \text{ VAR}} = 156.74 \Omega$$

$$\text{and } C = \frac{1}{2\pi f X_C} = \frac{1}{(2\pi)(60 \text{ Hz})(156.74 \Omega)} = \mathbf{16.93 \mu\text{F}}$$

$$\text{b. } S_T = \sqrt{(24 \text{ kW})^2 + [7.9 \text{ kVAR (L)}]^2} = 25.27 \text{ kVA}$$

$$I_T = \frac{S_T}{E} = \frac{25.27 \text{ kVA}}{1000 \text{ V}} = \mathbf{25.27 \text{ A}}$$

The new I_T is

$$I_T = 25.27 \text{ A } \angle 27.93 \text{ A} \quad (\text{original})$$

19.9 WATTMETERS AND POWER-FACTOR METERS

The electrodynamic wattmeter was introduced in Section 4.4 along with its movement and terminal connections. The same meter can be used to measure the power in a dc or an ac network using the same connection strategy; in fact, it can be used to measure the wattage of any network with a periodic or a nonperiodic input.

The digital display wattmeter of Fig. 19.30 employs a sophisticated electronic package to sense the voltage and current levels and, through the use of an analog-to-digital conversion unit, display the proper digits on the display. It is capable of providing a digital readout for distorted nonsinusoidal waveforms, and it can provide the phase power, total power, apparent power, reactive power, and power factor.

When using a wattmeter, the operator must take care not to exceed the current, voltage, or wattage rating. The product of the voltage and current ratings may or may not equal the wattage rating. In the high-power-factor wattmeter, the product of the voltage and current ratings is usually equal to the wattage rating, or at least 80% of it. For a low-power-factor wattmeter, the product of the current and voltage ratings is much greater than the wattage rating. For obvious reasons, the low-power-factor meter is used only in circuits with low power factors (total impedance highly reactive). Typical ratings for high-power-factor (HPF) and low-power-factor (LPF) meters are shown in Table 19.2. Meters of both high and low power factors have an accuracy of 0.5% to 1% of full scale.



FIG. 19.30

Digital wattmeter. (Courtesy of Yokogawa Corporation of America)

TABLE 19.2

Meter	Current Ratings	Voltage Ratings	Wattage Ratings
HPF	2.5 A	150 V	1500/750/375
	5.0 A	300 V	
LPF	2.5 A	150 V	300/150/75
	5.0 A	300 V	

As the name implies, power-factor meters are designed to read the power factor of a load under operating conditions. Most are designed to be used on single- or three-phase systems. Both the voltage and the current are typically measured using nonintrusive methods; that is, connections are made directly to the terminals for the voltage measurements, whereas clamp-on current transformers are used to sense the current level, as shown for the power-factor meter of Fig. 19.31.

Once the power factor is known, most power-factor meters come with a set of tables that will help define the power-factor capacitor that should be used to improve the power factor. Power-factor capacitors are typically rated in kVAR, with typical ratings extending from 1 to 25 kVAR at 240 V and 1 to 50 kVAR at 480 V or 600 V.

19.10 EFFECTIVE RESISTANCE

The resistance of a conductor as determined by the equation $R = \rho(l/A)$ is often called the *dc*, *ohmic*, or *geometric* resistance. It is a constant quantity determined only by the material used and its physical dimensions. In ac circuits, the actual resistance of a conductor (called the **effective resistance**) differs from the dc resistance because of the varying currents and voltages that introduce effects not present in dc circuits.

These effects include radiation losses, skin effect, eddy currents, and hysteresis losses. The first two effects apply to any network, while the latter two are concerned with the additional losses introduced by the presence of ferromagnetic materials in a changing magnetic field.

Experimental Procedure

The effective resistance of an ac circuit cannot be measured by the ratio V/I since this ratio is now the impedance of a circuit that may have both resistance and reactance. The effective resistance can be found, however, by using the power equation $P = I^2R$, where

$$R_{\text{eff}} = \frac{P}{I^2} \quad (19.31)$$

A wattmeter and an ammeter are therefore necessary for measuring the effective resistance of an ac circuit.

Radiation Losses

Let us now examine the various losses in greater detail. The **radiation loss** is the loss of energy in the form of electromagnetic waves during the transfer of energy from one element to another. This loss in energy



FIG. 19.31
Clamp-on power-factor meter. (Courtesy of the AEMC Corporation.)

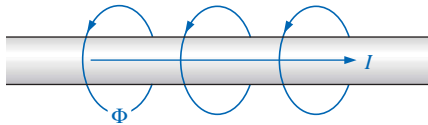

FIG. 19.32

Demonstrating the skin effect on the effective resistance of a conductor.

requires that the input power be larger to establish the same current I , causing R to increase as determined by Eq. (19.31). At a frequency of 60 Hz, the effects of radiation losses can be completely ignored. However, at radio frequencies, this is an important effect and may in fact become the main effect in an electromagnetic device such as an antenna.

Skin Effect

The explanation of **skin effect** requires the use of some basic concepts previously described. Remember from Chapter 11 that a magnetic field exists around every current-carrying conductor (Fig. 19.32). Since the amount of charge flowing in ac circuits changes with time, the magnetic field surrounding the moving charge (current) also changes. Recall also that a wire placed in a changing magnetic field will have an induced voltage across its terminals as determined by Faraday's law, $e = N \times (d\phi/dt)$. The higher the frequency of the changing flux as determined by an alternating current, the greater the induced voltage will be.

For a conductor carrying alternating current, the changing magnetic field surrounding the wire links the wire itself, thus developing within the wire an induced voltage that opposes the original flow of charge or current. These effects are more pronounced at the center of the conductor than at the surface because the center is linked by the changing flux inside the wire as well as that outside the wire. As the frequency of the applied signal increases, the flux linking the wire will change at a greater rate. An increase in frequency will therefore increase the counter-induced voltage at the center of the wire to the point where the current will, for all practical purposes, flow on the surface of the conductor. At 60 Hz, the skin effect is almost noticeable. However, at radio frequencies the skin effect is so pronounced that conductors are frequently made hollow because the center part is relatively ineffective. The skin effect, therefore, reduces the effective area through which the current can flow, and it causes the resistance of the conductor, given by the equation $R \uparrow = \rho(l/A \downarrow)$, to increase.

Hysteresis and Eddy Current Losses

As mentioned earlier, hysteresis and eddy current losses will appear when a ferromagnetic material is placed in the region of a changing magnetic field. To describe eddy current losses in greater detail, we will consider the effects of an alternating current passing through a coil wrapped around a ferromagnetic core. As the alternating current passes through the coil, it will develop a changing magnetic flux Φ linking both the coil and the core that will develop an induced voltage within the core as determined by Faraday's law. This induced voltage and the geometric resistance of the core $R_C = \rho(l/A)$ cause currents to be developed within the core, $i_{\text{core}} = (e_{\text{ind}}/R_C)$, called **eddy currents**. The currents flow in circular paths, as shown in Fig. 19.33, changing direction with the applied ac potential.

The eddy current losses are determined by

$$P_{\text{eddy}} = i_{\text{eddy}}^2 R_{\text{core}}$$

The magnitude of these losses is determined primarily by the type of core used. If the core is nonferromagnetic—and has a high resistivity like wood or air—the eddy current losses can be neglected. In terms of the frequency of the applied signal and the magnetic field strength pro-

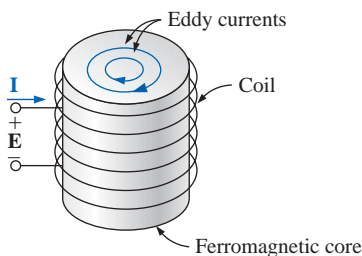

FIG. 19.33

Defining the eddy current losses of a ferromagnetic core.

duced, the eddy current loss is proportional to the square of the frequency times the square of the magnetic field strength:

$$P_{\text{eddy}} \propto f^2 B^2$$

Eddy current losses can be reduced if the core is constructed of thin, laminated sheets of ferromagnetic material insulated from one another and aligned parallel to the magnetic flux. Such construction reduces the magnitude of the eddy currents by placing more resistance in their path.

Hysteresis losses were described in Section 11.8. You will recall that in terms of the frequency of the applied signal and the magnetic field strength produced, the hysteresis loss is proportional to the frequency to the 1st power times the magnetic field strength to the n th power:

$$P_{\text{hys}} \propto f^1 B^n$$

where n can vary from 1.4 to 2.6, depending on the material under consideration.

Hysteresis losses can be effectively reduced by the injection of small amounts of silicon into the magnetic core, constituting some 2% or 3% of the total composition of the core. This must be done carefully, however, because too much silicon makes the core brittle and difficult to machine into the shape desired.

EXAMPLE 19.7

- a. An air-core coil is connected to a 120-V, 60-Hz source as shown in Fig. 19.34. The current is found to be 5 A, and a wattmeter reading of 75 W is observed. Find the effective resistance and the inductance of the coil.

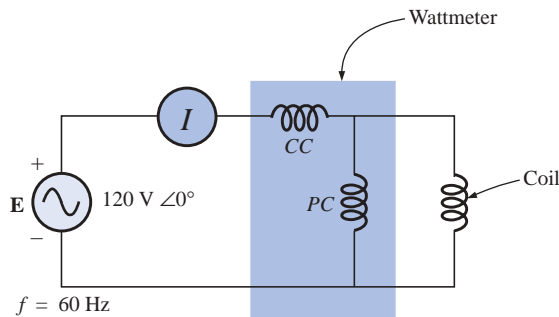

FIG. 19.34

The basic components required to determine the effective resistance and inductance of the coil.

- b. A brass core is then inserted in the coil. The ammeter reads 4 A, and the wattmeter 80 W. Calculate the effective resistance of the core. To what do you attribute the increase in value over that of part (a)?
- c. If a solid iron core is inserted in the coil, the current is found to be 2 A, and the wattmeter reads 52 W. Calculate the resistance and the inductance of the coil. Compare these values to those of part (a), and account for the changes.

Solutions:

$$\text{a. } R = \frac{P}{I^2} = \frac{75 \text{ W}}{(5 \text{ A})^2} = \mathbf{3 \Omega}$$

$$Z_T = \frac{E}{I} = \frac{120 \text{ V}}{5 \text{ A}} = 24 \Omega$$

$$X_L = \sqrt{Z_T^2 - R^2} = \sqrt{(24 \Omega)^2 - (3 \Omega)^2} = 23.81 \Omega$$

$$\text{and } X_L = 2\pi fL$$

$$\text{or } L = \frac{X_L}{2\pi f} = \frac{23.81 \Omega}{377 \text{ rad/s}} = \mathbf{63.16 \text{ mH}}$$

$$\text{b. } R = \frac{P}{I^2} = \frac{80 \text{ W}}{(4 \text{ A})^2} = \frac{80 \Omega}{16} = \mathbf{5 \Omega}$$

The brass core has less reluctance than the air core. Therefore, a greater magnetic flux density B will be created in it. Since $P_{\text{eddy}} \propto f^2 B^2$, and $P_{\text{hys}} \propto f^1 B^n$, as the flux density increases, the core losses and the effective resistance increase.

$$\text{c. } R = \frac{P}{I^2} = \frac{52 \text{ W}}{(2 \text{ A})^2} = \frac{52 \Omega}{4} = \mathbf{13 \Omega}$$

$$Z_T = \frac{E}{I} = \frac{120 \text{ V}}{2 \text{ A}} = 60 \Omega$$

$$X_L = \sqrt{Z_T^2 - R^2} = \sqrt{(60 \Omega)^2 - (13 \Omega)^2} = 58.57 \Omega$$

$$L = \frac{X_L}{2\pi f} = \frac{58.57 \Omega}{377 \text{ rad/s}} = \mathbf{155.36 \text{ mH}}$$

The iron core has less reluctance than the air or brass cores. Therefore, a greater magnetic flux density B will be developed in the core. Again, since $P_{\text{eddy}} \propto f^2 B^2$, and $P_{\text{hys}} \propto f^1 B^n$, the increased flux density will cause the core losses and the effective resistance to increase.

Since the inductance L is related to the change in flux by the equation $L = N (d\phi/di)$, the inductance will be greater for the iron core because the changing flux linking the core will increase.

19.11 APPLICATIONS**Portable Power Generators****FIG. 19.35**

Single-phase portable generator. (Courtesy of Coleman Powermate, Inc.)

Even though it may appear that 120 V ac are just an extension cord away, there are times—such as in a remote cabin, on a job site, or while camping—that we are reminded that not every corner of the globe is connected to an electric power source. As you travel further away from large urban communities, gasoline generators such as shown in Fig. 19.35 appear in increasing numbers in hardware stores, lumber yards, and other retail establishments to meet the needs of the local community. Since ac generators are driven by a gasoline motor, they must be properly ventilated and cannot be run indoors. Usually, because of the noise and fumes that result, they are placed as far away as possible and are connected by a long, heavy-duty, weather-resistant extension cord. Any connection points must be properly protected and placed to ensure that the connections will not sit in a puddle of water or be sensitive to heavy rain or snow. Although there is some effort involved in setting up generators and constantly ensuring that they have enough gas, most users will tell you that they are worth their weight in gold.

The vast majority of generators are built to provide between 1750 W and 5000 W of power, although larger units can provide up to 20,000 W. At first encounter, you might assume that you can run the world on 5000 W. However, keep in mind that the unit purchased should be rated at least 20% above your expected load because of surge currents that result when appliances, motors, tools, etc., are turned on. Remember that even a light bulb develops a large turn-on current due to the cold, low-resistance state of the filament. If you work too closely to the rated capacity, experiences such as a severe drop in lighting can result when an electric saw is turned on—almost to the point where it appears that the lights will go out altogether. Generators are like any other piece of equipment: If you apply a load that is too heavy, they will shut down. Most have protective fuses or circuit breakers to ensure that the excursions above rated conditions are monitored and not exceeded beyond reason. The 20% protective barrier drops the output power from a 5000-W unit to 4000 W, and already we begin to wonder about the load we can apply. Although 4000 W would be sufficient to run a number of 60-W bulbs, a TV, an oil burner, and so on, troubles develop whenever a unit is hooked up for direct heating (such as heaters, hair dryers, and clothes dryers). Even microwaves at 1200 W command quite a power drain. Pile on a small electric heater at 1500 W with six 60-W bulbs (360 W), a 250-W TV, and a 250-W oil burner, and then turn on an electric hair dryer at 1500 W—suddenly you are very close to your maximum of 4000 W. It doesn't take long to push the limits when it comes to energy-consuming appliances.

Table 19.3 provides a list of specifications for the broad range of portable gasoline generators. Since the heaviest part of a generator is the gasoline motor, anything over 5 hp gets pretty heavy, especially when you add the weight of the gasoline. Most good units providing over 2400 W will have receptacles for 120 V and 220 V at various current levels, with an outlet for 12 V dc. They are also built so that they tolerate outdoor conditions of a reasonable nature and can run continuously for long periods of time. At 120 V, a 5000-W unit can provide a maximum current of about 42 A.

TABLE 19.3*Specifications for portable gasoline-driven ac generators.*

Continuous output power	1750–3000 W	2000–5000 W	2250–7500 W
Horsepower of gas motor	4–11 hp	5–14 hp	5–16 hp
Continuous output current	At 120 V: 15–25 A At 220 V(3 ϕ): 8–14 A	At 120 V: 17–42 A At 220 V(3 ϕ): 9–23 A	At 120 V: 19–63 A At 220 V(3 ϕ): 10–34 A
Output voltage	120 V or 3 ϕ : 120 V/220 V	120 V or 3 ϕ : 120 V/220 V	120 V or 3 ϕ : 120 V/220 V
Receptacles	2	2–4	2–4
Fuel tank	$\frac{1}{2}$ to 2 gallons gasoline	$\frac{1}{2}$ to 3 gallons gasoline	1 to 5 gallons gasoline

Business Sense

Because of the costs involved, every large industrial plant must continuously review its electric utility bill to ensure its accuracy and to consider ways that will keep it in check. As described in this chapter, the

power factor associated with the plant as a whole can have a measurable effect on the drain current and therefore the kVA drain on the power line. Power companies are aware of this problem and actually add a surcharge if the power factor fades below about 0.9. In other words, to ensure that the load appears as resistive in nature as possible, the power company is asking every user to try to ensure that his power factor is between 0.9 and 1 so that the kW demand is very close to the kVA demand. Power companies do give some leeway, but they don't want it to get out of hand.

Consider the following monthly bill for a fairly large industrial plant:

kWh consumption	146.5 MWh
peak kW demand	241 kW
kW demand	233 kW
kVA demand	250 kVA

The rate schedule provided by the local power authority is the following:

Energy	First 450 kWh @ 22.3¢/kWh	Next 12 MWh @ 17.1¢/kWh
	Additional kWh @ 8.9¢/kWh	
Power	First 240 kW @ free	
	Additional kW @ \$12.05/kW	

Note that this rate schedule has an energy cost breakdown and a power breakdown. This second fee is the one sensitive to the overall power factor of the plant.

The electric bill for the month is then calculated as follows:

$$\begin{aligned}
 \text{Cost} &= (450 \text{ kWh})(22.3¢/\text{kWh}) + (12 \text{ MWh})(17.1¢/\text{kWh}) \\
 &\quad + [146.2 \text{ MWh} - (12 \text{ MWh} + 450 \text{ kWh})](8.9¢/\text{kWh}) \\
 &= \$100.35 + \$2052.00 + \$11,903.75 \\
 &= \mathbf{\$14,056.10}
 \end{aligned}$$

Before examining the effect of the power fee structure, we can find the overall power factor of the load for the month with the following ratio taken from the monthly statement:

$$F_p = \frac{P}{P_a} = \frac{233 \text{ kW}}{250 \text{ kVA}} = \mathbf{0.932}$$

Since the power factor is larger than 0.9, the chances are that there will not be a surcharge or that the surcharge will be minimal.

When the power component of the bill is determined, the kVA demand is multiplied by the magic number of 0.9 to determine a kW level at this power factor. This kW level is compared to the metered level, and the consumer pays for the higher level.

In this case, if we multiply the 250 kVA by 0.9, we obtain 225 kW which is slightly less than the metered level of 233 kW. However, both levels are less than the free level of 240 kW, so there is no additional charge for the power component. The total bill remains at \$14,056.10.

If the kVA demand of the bill were 388 kVA with the kW demand staying at 233 kW, the situation would change because 0.9 times 388 kVA would result in 349.2 kW which is much greater than the metered 233 kW. The 349.2 kW would then be used to determine the bill as follows:

$$349.2 \text{ kW} - 240 \text{ kW} = 109.2 \text{ kW}$$

$$(109.2 \text{ kW})(\$12.05/\text{kW}) = \mathbf{\$1315.86}$$

which is significant.

The total bill can then be determined as follows:

$$\text{Cost} = \$14,056.10 + \$1,315.86$$

$$= \mathbf{\$15,371.96}$$

Thus, the power factor of the load dropped to $233 \text{ kW}/388 \text{ kVA} = 0.6$ which would put an unnecessary additional load on the power plant. It is certainly time to consider the power-factor-correction option as described in this text. It is not uncommon to see large capacitors sitting at the point where power enters a large industrial plant to perform a needed level of power-factor correction.

All in all, therefore, it is important to fully understand the impact of a poor power factor on a power plant—whether you someday work for the supplier or for the consumer.

19.12 COMPUTER ANALYSIS

PSpice

Power Curve: Resistor The computer analysis will begin with a verification of the curves of Fig. 19.3 which show the in-phase relationship between the voltage and current of a resistor. The figure shows that the power curve is totally above the horizontal axis and that the curve has a frequency twice the applied frequency and a peak value equal to twice the average value. First the simple schematic of Fig. 19.36 must

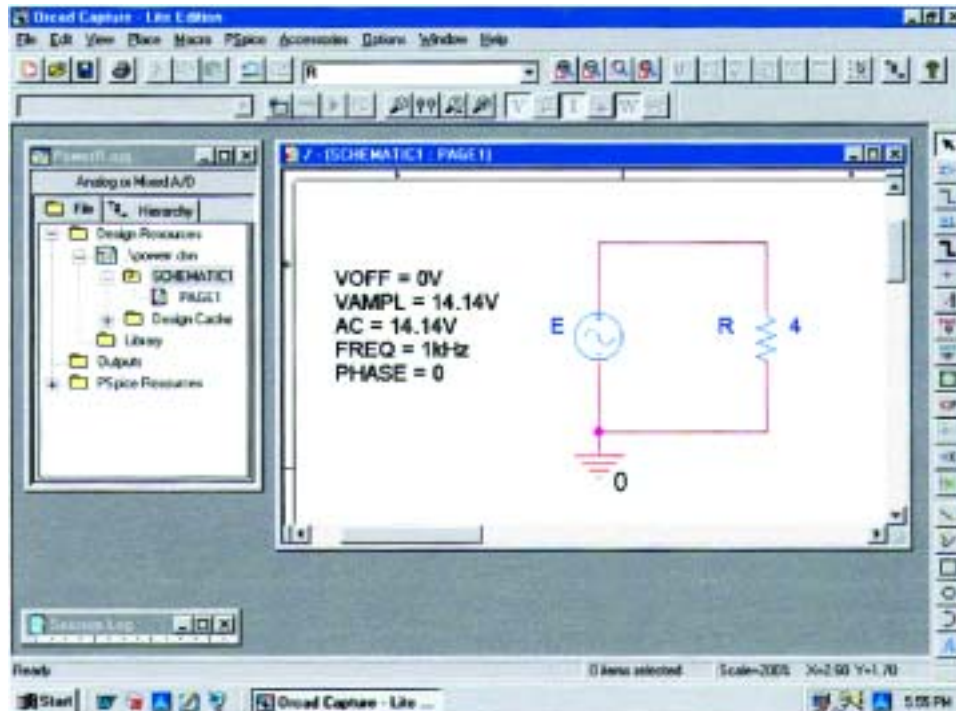

FIG. 19.36

Using PSpice to review the power curve for a resistive element in an ac circuit.

be set up. Then, using the **Time Domain(Transient)** option to get a plot versus time and setting the **Run to time** to 1 ms and the **Maximum step size** to $1 \text{ ms}/1000 = 1 \mu\text{s}$, we select **OK** and then the **Run PSpice** icon to perform the simulation. Then **Trace-Add Trace-V1(R)** will result in the curve appearing in Fig. 19.37. Next, **Trace-Add Trace-I(R)** will result in the curve for the current as appearing in Fig. 19.37. Finally the power curve will be plotted using **Trace-Add Trace-V1(R)*I(R)** from the basic power equation, and the larger curve of Fig. 19.37 will result. The original plot had a y-axis that extended from -50 to $+50$. Since all of the data points are from -20 to $+50$, the y-axis was changed to this new range through **Plot-Axis Settings-Y Axis-User Defined-(-20 to +50)-OK** to obtain the plot of Fig. 19.37.

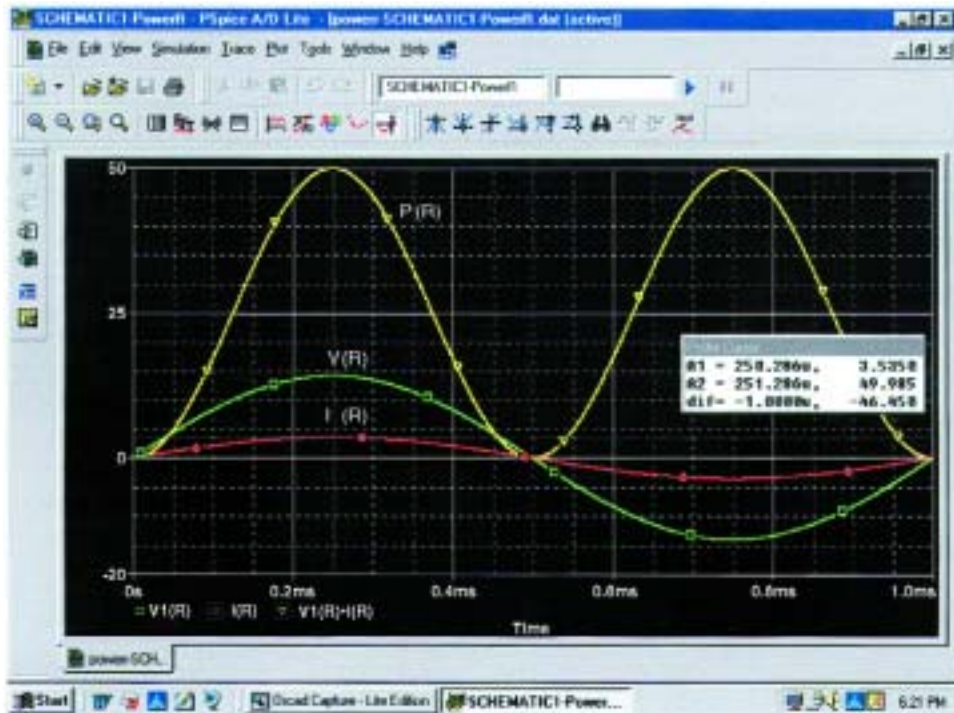

FIG. 19.37

The resulting plots for the power, voltage, and current for the resistor of Fig. 19.36.

You can distinguish between the curves by simply looking at the symbol next to each quantity at the bottom left of the plot. In this case, however, to make it even clearer, a different color was selected for each trace by clicking on each trace with a right click, selecting **Properties**, and choosing the color and width of each curve. However, you can also add text to the screen by selecting the **ABC** icon to obtain the **Text Label** dialog box, entering the label such as **P(R)**, and clicking **OK**. The label can then be placed anywhere on the screen. By selecting the **Toggle cursor** key and then clicking on **I(R)** at the bottom of the screen, we can use the cursor to find the maximum value of the current. At **A1** = $250 \mu\text{s}$ or $\frac{1}{4}$ of the total period of the input voltage, the current is a peak at 3.54 A. The peak value of the power curve can then be found by right-clicking on **V1(R)*I(R)**, clicking on the graph, and then finding the peak value (also available by simply clicking on the **Cursor**

Peak icon to the right of the **Toggle cursor** key). It occurs at the same point as the maximum current at a level of 50 W. In particular, note that the power curve shows two cycles, while both v_R and i_R show only one cycle. Clearly, the power curve has twice the frequency of the applied signal. Also note that the power curve is totally above the zero line, indicating that power is being absorbed by the resistor through the entire displayed cycle. Further, the peak value of the power curve is twice the average value of the curve; that is, the peak value of 50 W is twice the average value of 25 W.

The results of the above simulation can be verified by performing the longhand calculation using the rms value of the applied voltage. That is,

$$P = \frac{V_R^2}{R} = \frac{(10 \text{ V})^2}{4 \Omega} = 25 \text{ W}$$

Power Curves: Series R-L-C Circuit The network of Fig. 19.38, with its combination of elements, will now be used to demonstrate that, no matter what the physical makeup of the network, the average value of the power curve established by the product of the applied voltage and resulting source current is equal to that dissipated by the network. At a frequency of 1 kHz, the reactance of the 1.273-mH inductor will be 8, and the reactance of the capacitor will be 4 Ω, resulting in a lagging network. An analysis of the network will result in

$$Z_T = 4 \Omega + j4 \Omega = 5.657 \Omega \angle 45^\circ$$

with
$$I = \frac{E}{Z_T} = \frac{10 \text{ V} \angle 0^\circ}{5.657 \Omega \angle 45^\circ} = 1.768 \text{ A} \angle -45^\circ$$

and
$$P = I^2 R = (1.768 \text{ A})^2 4 \Omega = 12.5 \text{ W}$$

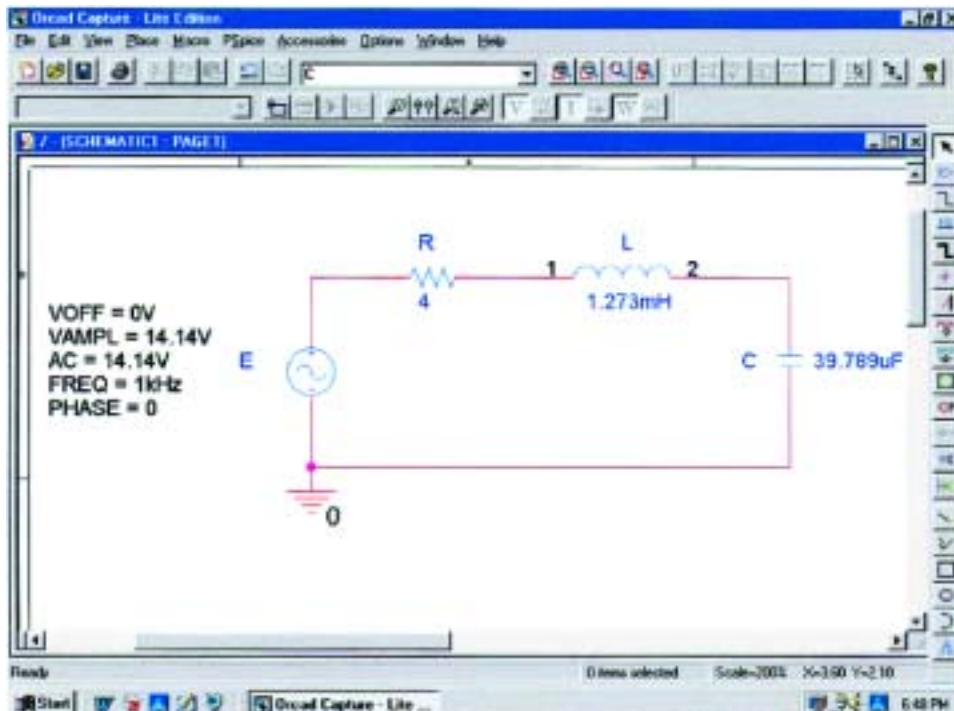

FIG. 19.38

Using PSpice to examine the power distribution in a series R-L-C circuit.

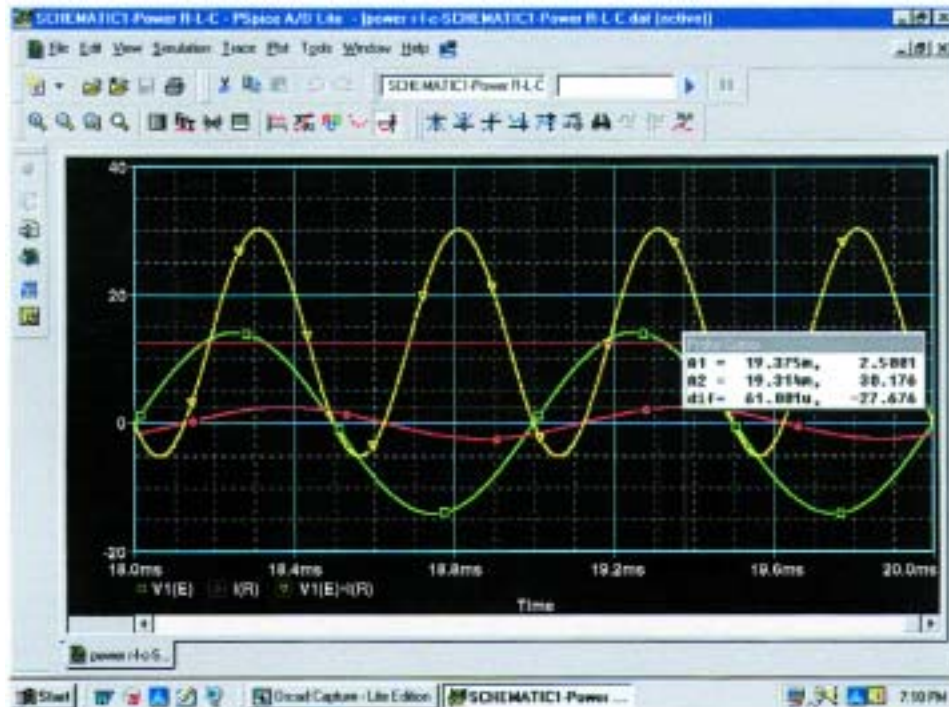

FIG. 19.39

Plots of the applied voltage e , current $i_R = i_s$, and power delivered $p_s = e \cdot i_s$ for the circuit of Fig. 19.38.

The three curves of Fig. 19.39 were obtained using the **Simulation Output Variables** $V(E: +)$, $I(R)$, and $V(E: +) \cdot I(R)$. The **Run to time** under the **Simulation Profile** listing was 20 ms, although $1 \mu\text{s}$ was chosen as the **Maximum step size** to ensure a good plot. In particular, note that the horizontal axis does not start until $t = 18 \text{ ms}$ to ensure that we are in a steady-state mode and not in a transient stage (where the peak values of the waveforms could change with time). The horizontal axis was set to extend from 18 ms to 20 ms by simply selecting **Plot-Axis Settings-X Axis-User Defined-18ms to 20ms-OK**. First note that the current lags the applied voltage as expected for the lagging network. The phase angle between the two is 45° as determined above. Second, be aware that the elements were chosen so that the same scale could be used for the current and voltage. The vertical axis does not have a unit of measurement, so the proper units must be mentally added for each plot. Using **Plot-Label-Line**, a line can be drawn across the screen at the average power level of 12.5 W. A pencil will appear that can be clicked in place at the left edge at the 12.5-W level. The pencil can then be dragged across the page to draw the desired line. Once you are at the right edge, remove the pressure on the mouse, and the line is drawn. The different colors for the traces were obtained simply by right-clicking on a trace and responding to the choices under **Properties**. Note that the 12.5-W level is indeed the average value of the power curve. It is interesting to note that the power curve dips below the axis for only a short period of time. In other words, during the two visible cycles, power is being absorbed by the circuit most of the time. The

small region below the axis is the return of energy to the network by the reactive elements. In general, therefore, the source must supply power to the circuit most of the time, even though a good percentage of the power may simply be delivering energy to the reactive elements and may not be dissipated.

PROBLEMS

SECTIONS 19.1 THROUGH 19.7

1. For the battery of bulbs (purely resistive) appearing in Fig. 19.40:
 - a. Determine the total power dissipation.
 - b. Calculate the total reactive and apparent power.
 - c. Find the source current I_s .
 - d. Calculate the resistance of each bulb for the specified operating conditions.
 - e. Determine the currents I_1 and I_2 .
2. For the network of Fig. 19.41:
 - a. Find the average power delivered to each element.
 - b. Find the reactive power for each element.
 - c. Find the apparent power for each element.
 - d. Find the total number of watts, volt-amperes reactive, and volt-amperes, and the power factor F_p of the circuit.
 - e. Sketch the power triangle.
 - f. Find the energy dissipated by the resistor over one full cycle of the input voltage.
 - g. Find the energy stored or returned by the capacitor and the inductor over one half-cycle of the power curve for each.

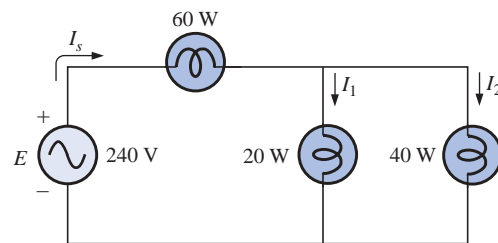

FIG. 19.40
Problem 1.

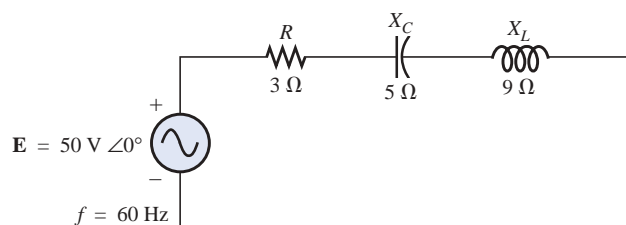

FIG. 19.41
Problem 2.

3. For the system of Fig. 19.42:
- Find the total number of watts, volt-amperes reactive, and volt-amperes, and the power factor F_p .
 - Draw the power triangle.
 - Find the current I_s .

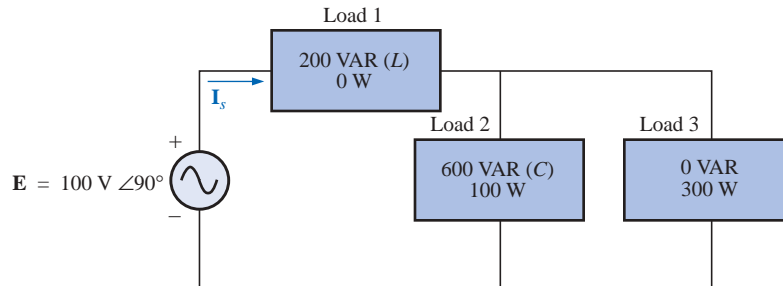

FIG. 19.42
Problem 3.

4. For the system of Fig. 19.43:
- Find P_T , Q_T , and S_T .
 - Determine the power factor F_p .
 - Draw the power triangle.
 - Find I_s .

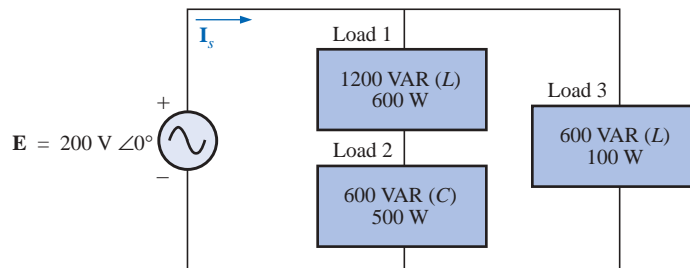

FIG. 19.43
Problem 4.

5. For the system of Fig. 19.44:
- Find P_T , Q_T , and S_T .
 - Find the power factor F_p .
 - Draw the power triangle.
 - Find I_s .

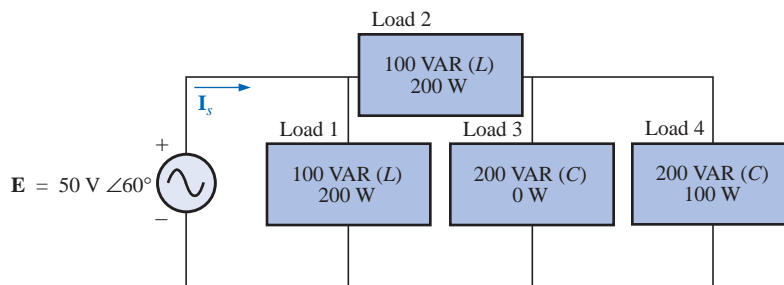

FIG. 19.44
Problem 5.

6. For the circuit of Fig. 19.45:
- Find the average, reactive, and apparent power for the 20-Ω resistor.
 - Repeat part (a) for the 10-Ω inductive reactance.
 - Find the total number of watts, volt-amperes reactive, and volt-amperes, and the power factor F_p .
 - Find the current I_s .

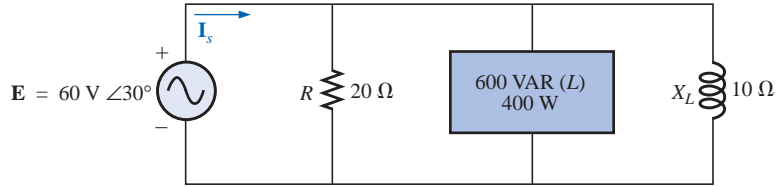

FIG. 19.45
Problem 6.

7. For the network of Fig. 19.46:
- Find the average power delivered to each element.
 - Find the reactive power for each element.
 - Find the apparent power for each element.
 - Find P_T , Q_T , S_T , and F_p for the system.
 - Sketch the power triangle.
 - Find I_s .

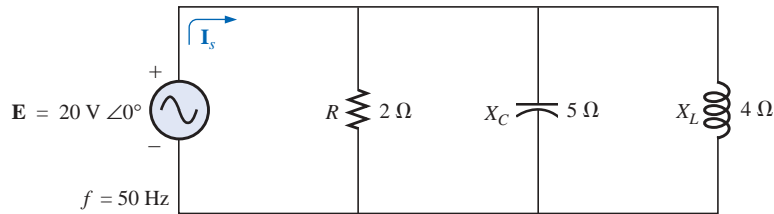

FIG. 19.46
Problem 7.

8. Repeat Problem 7 for the circuit of Fig. 19.47.

- *9. For the network of Fig. 19.48:
- Find the average power delivered to each element.
 - Find the reactive power for each element.
 - Find the apparent power for each element.
 - Find the total number of watts, volt-amperes reactive, and volt-amperes, and the power factor F_p of the circuit.
 - Sketch the power triangle.
 - Find the energy dissipated by the resistor over one full cycle of the input voltage.
 - Find the energy stored or returned by the capacitor and the inductor over one half-cycle of the power curve for each.

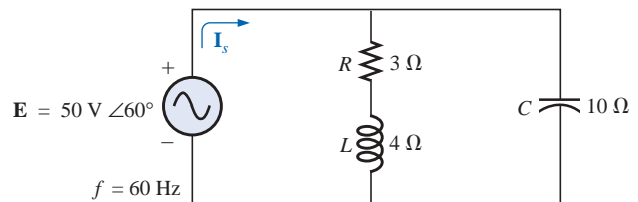

FIG. 19.47
Problem 8.

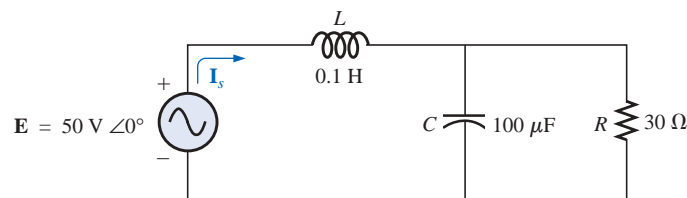

FIG. 19.48
Problem 9.

10. An electrical system is rated 10 kVA, 200 V at a 0.5 leading power factor.
- Determine the impedance of the system in rectangular coordinates.
 - Find the average power delivered to the system.
11. An electrical system is rated 5 kVA, 120 V, at a 0.8 lagging power factor.
- Determine the impedance of the system in rectangular coordinates.
 - Find the average power delivered to the system.
- *12. For the system of Fig. 19.49:
- Find the total number of watts, volt-amperes reactive, and volt-amperes, and F_p .
 - Find the current I_s .
 - Draw the power triangle.
 - Find the type of elements and their impedance in ohms within each electrical box. (Assume that all elements of a load are in series.)
 - Verify that the result of part (b) is correct by finding the current I_s using only the input voltage \mathbf{E} and the results of part (d). Compare the value of I_s with that obtained for part (b).

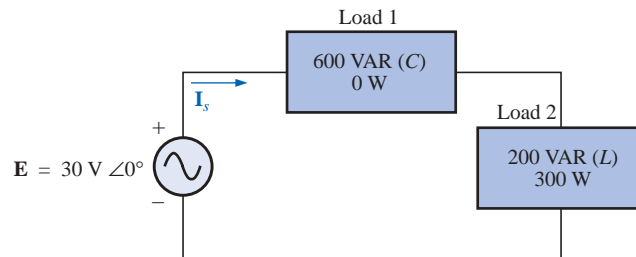

FIG. 19.49
Problem 12.

- *13. Repeat Problem 12 for the system of Fig. 19.50.

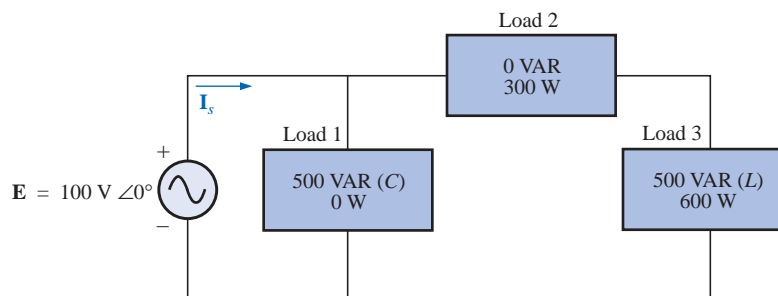

FIG. 19.50
Problem 13.

- *14. For the circuit of Fig. 19.51:
- Find the total number of watts, volt-amperes reactive, and volt-amperes, and F_p .
 - Find the current I_s .
 - Find the type of elements and their impedance in each box. (Assume that the elements within each box are in series.)

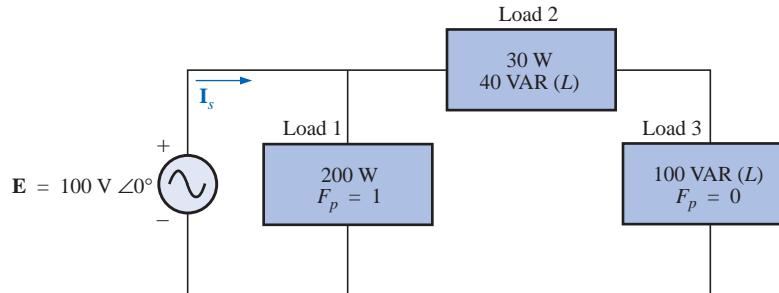

FIG. 19.51
Problem 14.

15. For the circuit of Fig. 19.52:
- Find the total number of watts, volt-amperes reactive, and volt-amperes, and F_p .
 - Find the voltage E .
 - Find the type of elements and their impedance in each box. (Assume that the elements within each box are in series.)

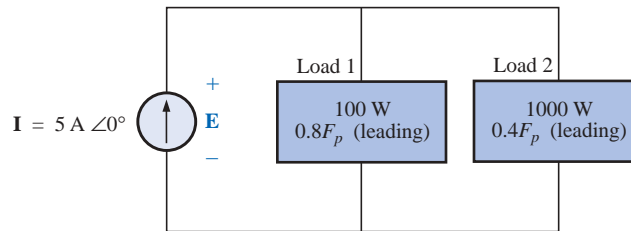

FIG. 19.52
Problem 15.

SECTION 19.8 Power-Factor Correction

- *16. The lighting and motor loads of a small factory establish a 10-kVA power demand at a 0.7 lagging power factor on a 208-V, 60-Hz supply.
- Establish the power triangle for the load.
 - Determine the power-factor capacitor that must be placed in parallel with the load to raise the power factor to unity.
 - Determine the change in supply current from the uncompensated to the compensated system.
 - Repeat parts (b) and (c) if the power factor is increased to 0.9.
17. The load on a 120-V, 60-Hz supply is 5 kW (resistive), 8 kVAR (inductive), and 2 kVAR (capacitive).
- Find the total kilovolt-amperes.
 - Determine the F_p of the combined loads.

- c. Find the current drawn from the supply.
 d. Calculate the capacitance necessary to establish a unity power factor.
 e. Find the current drawn from the supply at unity power factor, and compare it to the uncompensated level.
18. The loading of a factory on a 1000-V, 60-Hz system includes:
 20-kW heating (unity power factor)
 10-kW (P_i) induction motors (0.7 lagging power factor)
 5-kW lighting (0.85 lagging power factor)
- a. Establish the power triangle for the total loading on the supply.
 b. Determine the power-factor capacitor required to raise the power factor to unity.
 c. Determine the change in supply current from the uncompensated to the compensated system.

SECTION 19.9 Wattmeters and Power-Factor Meters

19. a. A wattmeter is connected with its current coil as shown in Fig. 19.53 and with the potential coil across points f - g . What does the wattmeter read?
 b. Repeat part (a) with the potential coil (PC) across a - b , b - c , a - c , a - d , c - d , d - e , and f - e .

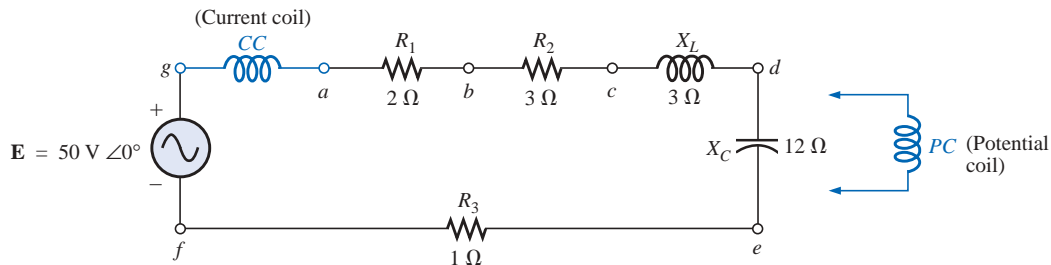

FIG. 19.53
 Problem 19.

20. The voltage source of Fig. 19.54 delivers 660 VA at 120 V, with a supply current that lags the voltage by a power factor of 0.6.
- a. Determine the voltmeter, ammeter, and wattmeter readings.
 b. Find the load impedance in rectangular form.

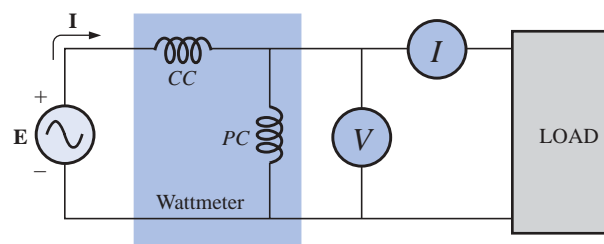

FIG. 19.54
 Problem 20.

SECTION 19.10 Effective Resistance

21. **a.** An air-core coil is connected to a 200-V, 60-Hz source. The current is found to be 4 A, and a wattmeter reading of 80 W is observed. Find the effective resistance and the inductance of the coil.
 - b.** A brass core is inserted in the coil. The ammeter reads 3 A, and the wattmeter reads 90 W. Calculate the effective resistance of the core. Explain the increase over the value of part (a).
 - c.** If a solid iron core is inserted in the coil, the current is found to be 2 A, and the wattmeter reads 60 W. Calculate the resistance and inductance of the coil. Compare these values to the values of part (a), and account for the changes.
22. **a.** The inductance of an air-core coil is 0.08 H, and the effective resistance is 4 Ω when a 60-V, 50-Hz source is connected across the coil. Find the current passing through the coil and the reading of a wattmeter across the coil.
 - b.** If a brass core is inserted in the coil, the effective resistance increases to 7 Ω , and the wattmeter reads 30 W. Find the current passing through the coil and the inductance of the coil.
 - c.** If a solid iron core is inserted in the coil, the effective resistance of the coil increases to 10 Ω , and the current decreases to 1.7 A. Find the wattmeter reading and the inductance of the coil.

SECTION 19.12 Computer Analysis**PSpice or Electronics Workbench**

23. Using PSpice or EWB, obtain a plot of reactive power for a pure capacitor of 636.62 μF at a frequency of 1 kHz for one cycle of the input voltage using an applied voltage $\mathbf{E} = 10 \text{ V} \angle 0^\circ$. On the same graph, plot both the applied voltage and the resulting current. Apply appropriate labels to the resulting curves to generate results similar to those in Fig. 19.37.
24. Repeat the analysis of Fig. 19.38 for a parallel R - L - C network of the same values and frequency.
25. Plot both the applied voltage and the source current on the same set of axes for the network of Fig. 19.27(b), and show that they are both in phase due to the resulting unity power factor.

Programming Language (C++, QBASIC, Pascal, etc.)

26. Write a program that provides a general solution for the network of Fig. 19.19. That is, given the resistance or reactance of each element and the source voltage at zero degrees, calculate the real, reactive, and apparent power of the system.
27. Write a program that will demonstrate the effect of increasing reactive power on the power factor of a system. Tabulate the real power, reactive power, and power factor of the system for a fixed real power and a reactive power that starts at 10% of the real power and continues through to five times the real power in increments of 10% of the real power.

GLOSSARY

Apparent power The power delivered to a load without consideration of the effects of a power-factor angle of the load. It is determined solely by the product of the terminal voltage and current of the load.

Average (real) power The delivered power dissipated in the form of heat by a network or system.

Eddy currents Small, circular currents in a paramagnetic core causing an increase in the power losses and the effective resistance of the material.

Effective resistance The resistance value that includes the effects of radiation losses, skin effect, eddy currents, and hysteresis losses.

Hysteresis losses Losses in a magnetic material introduced by changes in the direction of the magnetic flux within the material.

Power-factor correction The addition of reactive components (typically capacitive) to establish a system power factor closer to unity.

Radiation losses The loss of energy in the form of electromagnetic waves during the transfer of energy from one element to another.

Reactive power The power associated with reactive elements that provides a measure of the energy associated with setting up the magnetic and electric fields of inductive and capacitive elements, respectively.

Skin effect At high frequencies, a counter-induced voltage builds up at the center of a conductor, resulting in an increased flow near the surface (skin) of the conductor and a sharp reduction near the center. As a result, the effective area of conduction decreases and the resistance increases as defined by the basic equation for the geometric resistance of a conductor.

