

# Transformers

## 21.1 INTRODUCTION

Chapter 12 discussed the *self-inductance* of a coil. We shall now examine the **mutual inductance** that exists between coils of the same or different dimensions. Mutual inductance is a phenomenon basic to the operation of the *transformer*, an electrical device used today in almost every field of electrical engineering. This device plays an integral part in power distribution systems and can be found in many electronic circuits and measuring instruments. In this chapter, we will discuss three of the basic applications of a transformer: to build up or step down the voltage or current, to act as an impedance matching device, and to isolate (no physical connection) one portion of a circuit from another. In addition, we will introduce the **dot convention** and will consider the transformer equivalent circuit. The chapter will conclude with a word about writing mesh equations for a network with mutual inductance.

## 21.2 MUTUAL INDUCTANCE

A transformer is constructed of two coils placed so that the changing flux developed by one will link the other, as shown in Fig. 21.1. This

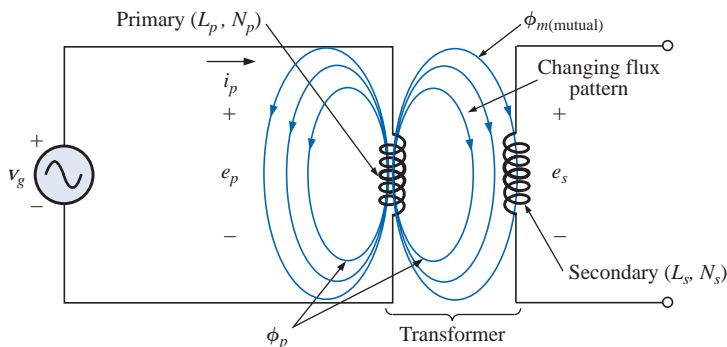


FIG. 21.1

Defining the components of a transformer.



will result in an induced voltage across each coil. To distinguish between the coils, we will apply the transformer convention that

*the coil to which the source is applied is called the primary, and the coil to which the load is applied is called the secondary.*

For the primary of the transformer of Fig. 21.1, an application of Faraday's law [Eq. (12.1)] will result in

$$e_p = N_p \frac{d\phi_p}{dt} \quad (\text{volts, V}) \quad (21.1)$$

revealing that the voltage induced across the primary is directly related to the number of turns in the primary and the rate of change of magnetic flux linking the primary coil. Or, from Eq. (12.5),

$$e_p = L_p \frac{di_p}{dt} \quad (\text{volts, V}) \quad (21.2)$$

revealing that the induced voltage across the primary is also directly related to the self-inductance of the primary and the rate of change of current through the primary winding.

The magnitude of  $e_s$ , the voltage induced across the secondary, is determined by

$$e_s = N_s \frac{d\phi_m}{dt} \quad (\text{volts, V}) \quad (21.3)$$

where  $N_s$  is the number of turns in the secondary winding and  $\phi_m$  is the portion of the primary flux  $\phi_p$  that links the secondary winding.

If all of the flux linking the primary links the secondary, then

$$\phi_m = \phi_p$$

and

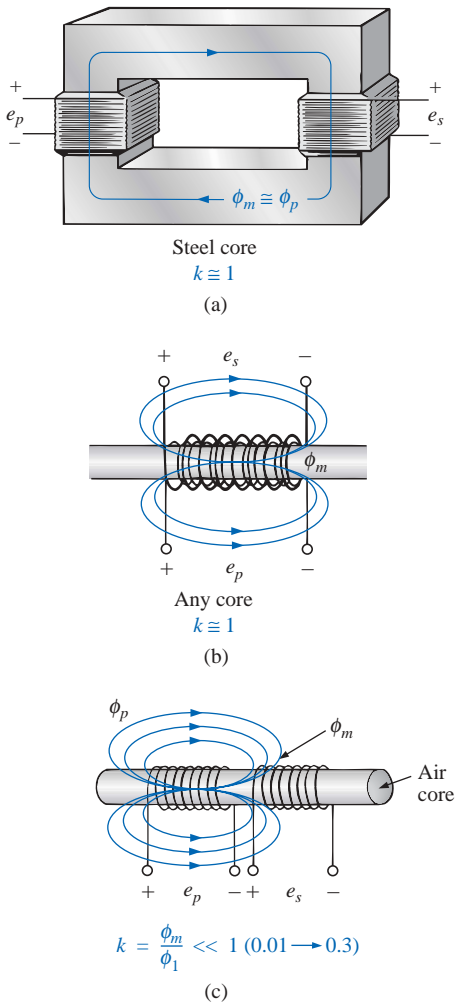
$$e_s = N_s \frac{d\phi_p}{dt} \quad (\text{volts, V}) \quad (21.4)$$

The **coefficient of coupling** ( $k$ ) between two coils is determined by

$$k \text{ (coefficient of coupling)} = \frac{\phi_m}{\phi_p} \quad (21.5)$$

*Since the maximum level of  $\phi_m$  is  $\phi_p$ , the coefficient of coupling between two coils can never be greater than 1.*

The coefficient of coupling between various coils is indicated in Fig. 21.2. In Fig. 21.2(a), the ferromagnetic steel core will ensure that most of the flux linking the primary will also link the secondary, establishing a coupling coefficient very close to 1. In Fig. 21.2(b), the fact that both coils are overlapping will result in the flux of one coil linking the other coil, with the result that the coefficient of coupling is again very close to 1. In Fig. 21.2(c), the absence of a ferromagnetic core will result in low levels of flux linkage between the coils. The closer the two coils are, the greater the flux linkage, and the higher the value of  $k$ , although



**FIG. 21.2**

*Windings having different coefficients of coupling.*



it will never approach a level of 1. Those coils with low coefficients of coupling are said to be **loosely coupled**.

For the secondary, we have

$$e_s = N_s \frac{d\phi_m}{dt} = N_s \frac{dk\phi_p}{dt}$$

and

$$e_s = kN_s \frac{d\phi_p}{dt} \quad (\text{volts, V}) \quad (21.6)$$

The mutual inductance between the two coils of Fig. 21.1 is determined by

$$M = N_s \frac{d\phi_m}{di_p} \quad (\text{henries, H}) \quad (21.7)$$

or

$$M = N_p \frac{d\phi_p}{di_s} \quad (\text{henries, H}) \quad (21.8)$$

Note in the above equations that the symbol for mutual inductance is the capital letter  $M$  and that its unit of measurement, like that of self-inductance, is the *henry*. In words, Equations (21.7) and (21.8) state that the

**mutual inductance between two coils is proportional to the instantaneous change in flux linking one coil due to an instantaneous change in current through the other coil.**

In terms of the inductance of each coil and the coefficient of coupling, the mutual inductance is determined by

$$M = k\sqrt{L_p L_s} \quad (\text{henries, H}) \quad (21.9)$$

The greater the coefficient of coupling (greater flux linkages), or the greater the inductance of either coil, the higher the mutual inductance between the coils. Relate this fact to the configurations of Fig. 21.2.

The secondary voltage  $e_s$  can also be found in terms of the mutual inductance if we rewrite Eq. (21.3) as

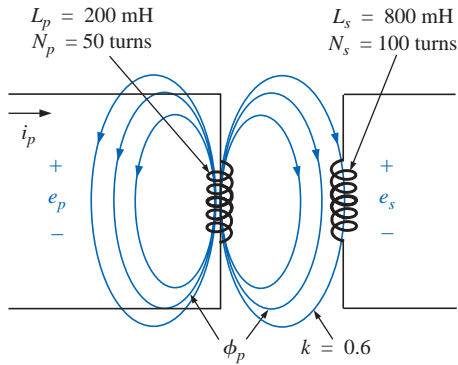
$$e_s = N_s \left( \frac{d\phi_m}{di_p} \right) \left( \frac{di_p}{dt} \right)$$

and, since  $M = N_s(d\phi_m/di_p)$ , it can also be written

$$e_s = M \frac{di_p}{dt} \quad (\text{volts, V}) \quad (21.10)$$

Similarly,

$$e_p = M \frac{di_s}{dt} \quad (\text{volts, V}) \quad (21.11)$$



**FIG. 21.3**  
Example 21.1.

**EXAMPLE 21.1** For the transformer in Fig. 21.3:

- Find the mutual inductance  $M$ .
- Find the induced voltage  $e_p$  if the flux  $\phi_p$  changes at the rate of 450 mWb/s.
- Find the induced voltage  $e_s$  for the same rate of change indicated in part (b).
- Find the induced voltages  $e_p$  and  $e_s$  if the current  $i_p$  changes at the rate of 0.2 A/ms.

**Solutions:**

$$\begin{aligned} \text{a. } M &= k\sqrt{L_p L_s} = 0.6\sqrt{(200 \text{ mH})(800 \text{ mH})} \\ &= 0.6\sqrt{16 \times 10^{-2}} = (0.6)(400 \times 10^{-3}) = \mathbf{240 \text{ mH}} \end{aligned}$$

$$\text{b. } e_p = N_p \frac{d\phi_p}{dt} = (50)(450 \text{ mWb/s}) = \mathbf{22.5 \text{ V}}$$

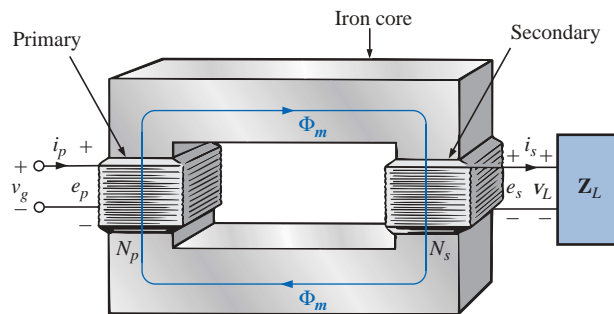
$$\text{c. } e_s = kN_s \frac{d\phi_p}{dt} = (0.6)(100)(450 \text{ mWb/s}) = \mathbf{27 \text{ V}}$$

$$\text{d. } e_p = L_p \frac{di_p}{dt} = (200 \text{ mH})(0.2 \text{ A/ms}) = (200 \text{ mH})(200 \text{ A/s}) = \mathbf{40 \text{ V}}$$

$$e_s = M \frac{di_p}{dt} = (240 \text{ mH})(200 \text{ A/s}) = \mathbf{48 \text{ V}}$$

## 21.3 THE IRON-CORE TRANSFORMER

An iron-core transformer under loaded conditions is shown in Fig. 21.4. The iron core will serve to increase the coefficient of coupling between the coils by increasing the mutual flux  $\phi_m$ . Recall from Chapter 11 that magnetic flux lines will always take the path of least reluctance, which in this case is the iron core.



**FIG. 21.4**  
Iron-core transformer.

In the analyses to follow in this chapter, we will assume that all of the flux linking coil 1 will link coil 2. In other words, the coefficient of coupling is its maximum value, 1, and  $\phi_m = \phi_p = \phi_s$ . In addition, we will first analyze the transformer from an ideal viewpoint; that is, we will neglect losses such as the geometric or dc resistance of the coils, the leakage reactance due to the flux linking either coil that forms no part of  $\phi_m$ , and the hysteresis and eddy current losses. This is not to convey the impression, however, that we will be far from the actual



operation of a transformer. Most transformers manufactured today can be considered almost ideal. The equations we will develop under ideal conditions will be, in general, a first approximation to the actual response, which will never be off by more than a few percentage points. The losses will be considered in greater detail in Section 21.6.

When the current  $i_p$  through the primary circuit of the iron-core transformer is a maximum, the flux  $\phi_m$  linking both coils is also a maximum. In fact, the magnitude of the flux is directly proportional to the current through the primary windings. Therefore, the two are in phase, and for sinusoidal inputs, the magnitude of the flux will vary as a sinusoid also. That is, if

$$i_p = \sqrt{2}I_p \sin \omega t$$

then

$$\phi_m = \Phi_m \sin \omega t$$

The induced voltage across the primary due to a sinusoidal input can be determined by Faraday's law:

$$e_p = N_p \frac{d\phi_p}{dt} = N_p \frac{d\phi_m}{dt}$$

Substituting for  $\phi_m$  gives us

$$e_p = N_p \frac{d}{dt}(\Phi_m \sin \omega t)$$

and differentiating, we obtain

$$e_p = \omega N_p \Phi_m \cos \omega t$$

or

$$e_p = \omega N_p \Phi_m \sin(\omega t + 90^\circ)$$

indicating that the induced voltage  $e_p$  leads the current through the primary coil by  $90^\circ$ .

The effective value of  $e_p$  is

$$E_p = \frac{\omega N_p \Phi_m}{\sqrt{2}} = \frac{2\pi f N_p \Phi_m}{\sqrt{2}}$$

and

$$E_p = 4.44fN_p\Phi_m \quad (21.12)$$

which is an equation for the rms value of the voltage across the primary coil in terms of the frequency of the input current or voltage, the number of turns of the primary, and the maximum value of the magnetic flux linking the primary.

For the case under discussion, where the flux linking the secondary equals that of the primary, if we repeat the procedure just described for the induced voltage across the secondary, we get

$$E_s = 4.44fN_s\Phi_m \quad (21.13)$$

Dividing Eq. (21.12) by Eq. (21.13), as follows:

$$\frac{E_p}{E_s} = \frac{4.44fN_p\Phi_m}{4.44fN_s\Phi_m}$$

we obtain



$$\boxed{\frac{E_p}{E_s} = \frac{N_p}{N_s}} \quad (21.14)$$

revealing an important relationship for transformers:

*The ratio of the magnitudes of the induced voltages is the same as the ratio of the corresponding turns.*

If we consider that

$$e_p = N_p \frac{d\phi_m}{dt} \quad \text{and} \quad e_s = N_s \frac{d\phi_m}{dt}$$

and divide one by the other, that is,

$$\frac{e_p}{e_s} = \frac{N_p(d\phi_m/dt)}{N_s(d\phi_m/dt)}$$

then 
$$\frac{e_p}{e_s} = \frac{N_p}{N_s}$$

The *instantaneous* values of  $e_1$  and  $e_2$  are therefore related by a constant determined by the turns ratio. Since their instantaneous magnitudes are related by a constant, the induced voltages are in phase, and Equation (21.14) can be changed to include phasor notation; that is,

$$\boxed{\frac{\mathbf{E}_p}{\mathbf{E}_s} = \frac{N_p}{N_s}} \quad (21.15)$$

or, since  $\mathbf{V}_g = \mathbf{E}_1$  and  $\mathbf{V}_L = \mathbf{E}_2$  for the ideal situation,

$$\boxed{\frac{\mathbf{V}_g}{\mathbf{V}_L} = \frac{N_p}{N_s}} \quad (21.16)$$

The ratio  $N_p/N_s$ , usually represented by the lowercase letter  $a$ , is referred to as the **transformation ratio**:

$$\boxed{a = \frac{N_p}{N_s}} \quad (21.17)$$

If  $a < 1$ , the transformer is called a **step-up transformer** since the voltage  $E_s > E_p$ ; that is,

$$\frac{E_p}{E_s} = \frac{N_p}{N_s} = a \quad \text{or} \quad E_s = \frac{E_p}{a}$$

and, if  $a < 1$ , 
$$E_s > E_p$$

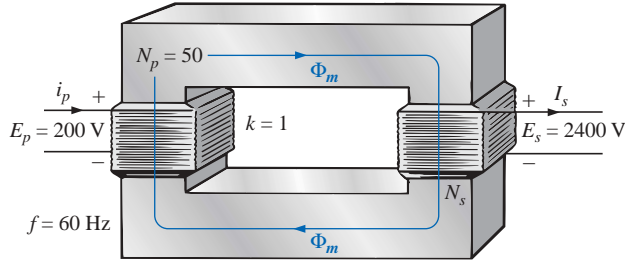
If  $a > 1$ , the transformer is called a **step-down transformer** since  $E_s < E_p$ ; that is,

$$E_p = aE_s$$

and, if  $a > 1$ , then 
$$E_p > E_s$$



**EXAMPLE 21.2** For the iron-core transformer of Fig. 21.5:



**FIG. 21.5**  
Example 21.2.

- Find the maximum flux  $\Phi_m$ .
- Find the secondary turns  $N_s$ .

**Solutions:**

a.  $E_p = 4.44N_p f \Phi_m$

$$\text{Therefore, } \Phi_m = \frac{E_p}{4.44N_p f} = \frac{200 \text{ V}}{(4.44)(50 \text{ t})(60 \text{ Hz})}$$

and  $\Phi_m = \mathbf{15.02 \text{ mWb}}$

b.  $\frac{E_p}{E_s} = \frac{N_p}{N_s}$

$$\text{Therefore, } N_s = \frac{N_p E_s}{E_p} = \frac{(50 \text{ t})(2400 \text{ V})}{200 \text{ V}} = \mathbf{600 \text{ turns}}$$

The induced voltage across the secondary of the transformer of Fig. 21.4 will establish a current  $i_s$  through the load  $Z_L$  and the secondary windings. This current and the turns  $N_s$  will develop an mmf  $N_s i_s$  that would not be present under no-load conditions since  $i_s = 0$  and  $N_s i_s = 0$ . Under loaded or unloaded conditions, however, the net ampere-turns on the core produced by both the primary and the secondary must remain unchanged for the same flux  $\phi_m$  to be established in the core. The flux  $\phi_m$  must remain the same to have the same induced voltage across the primary and to balance the voltage impressed across the primary. In order to counteract the mmf of the secondary, which is tending to change  $\phi_m$ , an additional current must flow in the primary. This current is called the *load component of the primary current* and is represented by the notation  $i'_p$ .

For the balanced or equilibrium condition,

$$N_p i'_p = N_s i_s$$

The total current in the primary under loaded conditions is

$$i_p = i'_p + i_{\phi_m}$$

where  $i_{\phi_m}$  is the current in the primary necessary to establish the flux  $\phi_m$ . For most practical applications,  $i'_p > i_{\phi_m}$ . For our analysis, we will assume  $i_p \cong i'_p$ , so

$$N_p i_p = N_s i_s$$



Since the instantaneous values of  $i_p$  and  $i_s$  are related by the turns ratio, the phasor quantities  $\mathbf{I}_p$  and  $\mathbf{I}_s$  are also related by the same ratio:

$$N_p \mathbf{I}_p = N_s \mathbf{I}_s$$

or

$$\boxed{\frac{\mathbf{I}_p}{\mathbf{I}_s} = \frac{N_s}{N_p}} \quad (21.18)$$

*The primary and secondary currents of a transformer are therefore related by the inverse ratios of the turns.*

Keep in mind that Equation (21.18) holds true only if we neglect the effects of  $i_{\phi_m}$ . Otherwise, the magnitudes of  $\mathbf{I}_p$  and  $\mathbf{I}_s$  are not related by the turns ratio, and  $\mathbf{I}_p$  and  $\mathbf{I}_s$  are not in phase.

For the step-up transformer,  $a < 1$ , and the current in the secondary,  $I_s = aI_p$ , is less in magnitude than that in the primary. For a step-down transformer, the reverse is true.

## 21.4 REFLECTED IMPEDANCE AND POWER

In the previous section we found that

$$\frac{\mathbf{V}_g}{\mathbf{V}_L} = \frac{N_p}{N_s} = a \quad \text{and} \quad \frac{\mathbf{I}_p}{\mathbf{I}_s} = \frac{N_s}{N_p} = \frac{1}{a}$$

Dividing the first by the second, we have

$$\frac{\mathbf{V}_g/\mathbf{V}_L}{\mathbf{I}_p/\mathbf{I}_s} = \frac{a}{1/a}$$

or

$$\frac{\mathbf{V}_g/\mathbf{I}_p}{\mathbf{V}_L/\mathbf{I}_s} = a^2 \quad \text{and} \quad \frac{\mathbf{V}_g}{\mathbf{I}_p} = a^2 \frac{\mathbf{V}_L}{\mathbf{I}_s}$$

However, since

$$\mathbf{Z}_p = \frac{\mathbf{V}_g}{\mathbf{I}_p} \quad \text{and} \quad \mathbf{Z}_L = \frac{\mathbf{V}_L}{\mathbf{I}_s}$$

then

$$\boxed{\mathbf{Z}_p = a^2 \mathbf{Z}_L} \quad (21.19)$$

which in words states that the impedance of the primary circuit of an ideal transformer is the transformation ratio squared times the impedance of the load. If a transformer is used, therefore, an impedance can be made to appear larger or smaller at the primary by placing it in the secondary of a step-down ( $a > 1$ ) or step-up ( $a < 1$ ) transformer, respectively. Note that if the load is capacitive or inductive, the **reflected impedance** will also be capacitive or inductive.

For the ideal iron-core transformer,

$$\frac{E_p}{E_s} = a = \frac{I_s}{I_p}$$

or

$$\boxed{E_p I_p = E_s I_s} \quad (21.20)$$

and

$$\boxed{P_{\text{in}} = P_{\text{out}}} \quad (\text{ideal conditions}) \quad (21.21)$$



**EXAMPLE 21.3** For the iron-core transformer of Fig. 21.6:

- Find the magnitude of the current in the primary and the impressed voltage across the primary.
- Find the input resistance of the transformer.

**Solutions:**

$$a. \frac{I_p}{I_s} = \frac{N_s}{N_p}$$

$$I_p = \frac{N_s}{N_p} I_s = \left( \frac{5 \text{ t}}{40 \text{ t}} \right) (0.1 \text{ A}) = \mathbf{12.5 \text{ mA}}$$

$$V_L = I_s Z_L = (0.1 \text{ A})(2 \text{ k}\Omega) = 200 \text{ V}$$

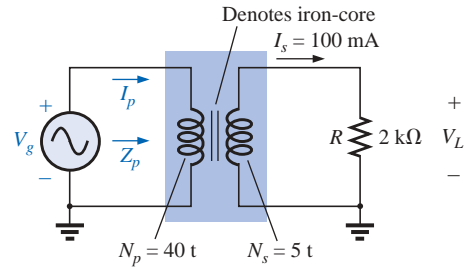
Also, 
$$\frac{V_g}{V_L} = \frac{N_p}{N_s}$$

$$V_g = \frac{N_p}{N_s} V_L = \left( \frac{40 \text{ t}}{5 \text{ t}} \right) (200 \text{ V}) = \mathbf{1600 \text{ V}}$$

b.  $Z_p = a^2 Z_L$

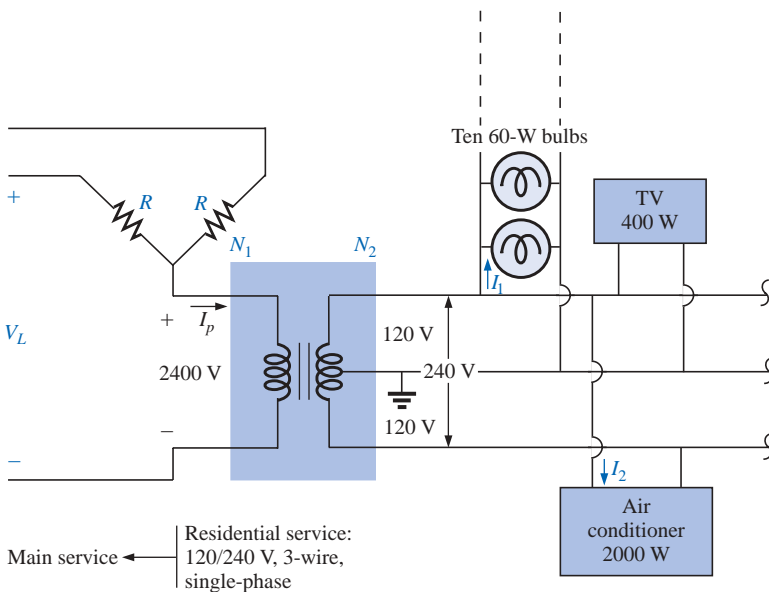
$$a = \frac{N_p}{N_s} = 8$$

$$Z_p = (8)^2 (2 \text{ k}\Omega) = R_p = \mathbf{128 \text{ k}\Omega}$$



**FIG. 21.6**  
Example 21.3.

**EXAMPLE 21.4** For the residential supply appearing in Fig. 21.7, determine (assuming a totally resistive load) the following:



**FIG. 21.7**  
Single-phase residential supply.

- the value of  $R$  to ensure a balanced load
- the magnitude of  $I_1$  and  $I_2$
- the line voltage  $V_L$
- the total power delivered
- the turns ratio  $a = N_p/N_s$

**Solutions:**

$$\begin{aligned} \text{a. } P_T &= (10)(60 \text{ W}) + 400 \text{ W} + 2000 \text{ W} \\ &= 600 \text{ W} + 400 \text{ W} + 2000 \text{ W} = 3000 \text{ W} \end{aligned}$$

$$P_{\text{in}} = P_{\text{out}}$$

$$V_p I_p = V_s I_s = 3000 \text{ W (purely resistive load)}$$

$$(2400 \text{ V})I_p = 3000 \text{ W and } I_p = 1.25 \text{ A}$$

$$R = \frac{V_\phi}{I_p} = \frac{2400 \text{ V}}{1.25 \text{ A}} = \mathbf{1920 \ \Omega}$$

$$\text{b. } P_1 = 600 \text{ W} = VI_1 = (120 \text{ V})I_1$$

$$\text{and } I_1 = \mathbf{5 \text{ A}}$$

$$P_2 = 2000 \text{ W} = VI_2 = (240 \text{ V})I_2$$

$$\text{and } I_2 = \mathbf{8.33 \text{ A}}$$

$$\text{c. } V_L = \sqrt{3}V_\phi = 1.73(2400 \text{ V}) = \mathbf{4152 \text{ V}}$$

$$\text{d. } P_T = 3P_\phi = 3(3000 \text{ W}) = \mathbf{9 \text{ kW}}$$

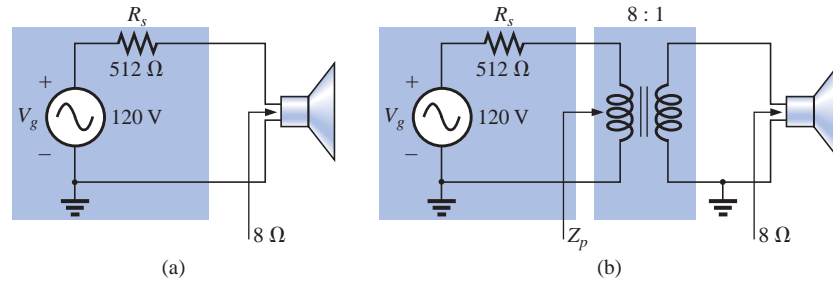
$$\text{e. } a = \frac{N_p}{N_s} = \frac{V_p}{V_s} = \frac{2400 \text{ V}}{240 \text{ V}} = \mathbf{10}$$

## 21.5 IMPEDANCE MATCHING, ISOLATION, AND DISPLACEMENT

Transformers can be particularly useful when you are trying to ensure that a load receives maximum power from a source. Recall that maximum power is transferred to a load when its impedance is a match with the internal resistance of the supply. Even if a perfect match is unattainable, the closer the load matches the internal resistance, the greater the power to the load and the more efficient the system. Unfortunately, unless it is planned as part of the design, most loads are not a close match with the internal impedance of the supply. However, transformers have a unique relationship between their primary and secondary impedances that can be put to good use in the impedance matching process. Example 21.5 will demonstrate the significant difference in the power delivered to the load with and without an impedance matching transformer.

### EXAMPLE 21.5

- The source impedance for the supply of Fig. 21.8(a) is  $512 \ \Omega$ , which is a poor match with the  $8\text{-}\Omega$  input impedance of the speaker. One can expect only that the power delivered to the speaker will be significantly less than the maximum possible level. Determine the power to the speaker under the conditions of Fig. 21.8(a).
- In Fig. 21.8(b), an audio impedance matching transformer was introduced between the speaker and the source, and it was designed to ensure maximum power to the  $8\text{-}\Omega$  speaker. Determine the input impedance of the transformer and the power delivered to the speaker.
- Compare the power delivered to the speaker under the conditions of parts (a) and (b).



**FIG. 21.8**  
Example 21.5.

**Solutions:**

a. The source current:

$$I_s = \frac{E}{R_T} = \frac{120 \text{ V}}{512 \Omega + 8 \Omega} = \frac{120 \text{ V}}{520 \Omega} = 230.8 \text{ mA}$$

The power to the speaker:

$$P = I^2 R = (230.8 \text{ mA})^2 \cdot 8 \Omega = \mathbf{426.15 \text{ mW} \cong 0.43 \text{ W}}$$

or less than half a watt.

b.  $Z_p = a^2 Z_L$

$$a = \frac{N_p}{N_s} = \frac{8}{1} = 8$$

and  $Z_p = (8)^2 8 \Omega = \mathbf{512 \Omega}$

which matches that of the source. Maximum power transfer conditions have been established, and the source current is now determined by

$$I_s = \frac{E}{R_T} = \frac{120 \text{ V}}{512 \Omega + 512 \Omega} = \frac{120 \text{ V}}{1024 \Omega} = 117.19 \text{ mA}$$

The power to the primary (which equals that to the secondary for the ideal transformer) is

$$P = I^2 R = (117.19 \text{ mA})^2 512 \Omega = \mathbf{7.032 \text{ W}}$$

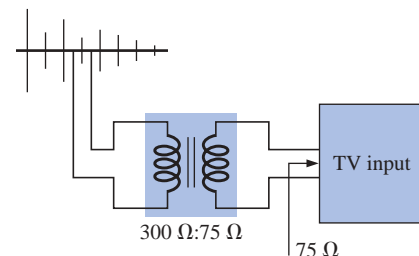
The result is not in milliwatts, as obtained above, and exceeds 7 W, which is a significant improvement.

c. Comparing levels,  $7.032 \text{ W}/426.15 \text{ mW} = 16.5$ , or more than 16 times the power delivered to the speaker using the impedance matching transformer.

Another important application of the impedance matching capabilities of a transformer is the matching of the 300-Ω twin line transmission line from a television antenna to the 75-Ω input impedance of today's televisions (ready-made for the 75-Ω coaxial cable), as shown in Fig. 21.9. A match must be made to ensure the strongest signal to the television receiver.

Using the equation  $Z_p = a^2 Z_L$  we find

$$300 \Omega = a^2 75 \Omega$$



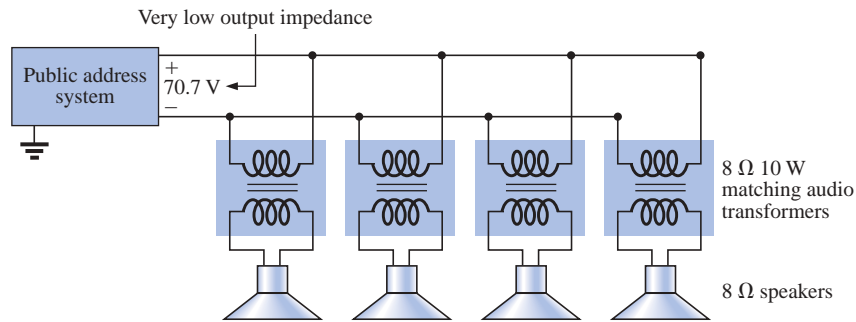
**FIG. 21.9**  
Television impedance matching transformer.



and 
$$a = \sqrt{\frac{300 \Omega}{75 \Omega}} = \sqrt{4} = 2$$

with  $N_p : N_s = 2 : 1$  (a step-down transformer)

**EXAMPLE 21.6** Impedance matching transformers are also quite evident in public address systems, such as the one appearing in the 70.7-V system of Fig. 21.10. Although the system has only one set of output terminals, up to four speakers can be connected to this system (the number is a function of the chosen system). Each 8-Ω speaker is connected to the 70.7-V line through a 10-W audio-matching transformer (defining the frequency range of linear operation).



**FIG. 21.10**  
Public address system.

- If each speaker of Fig. 21.10 can receive 10 W of power, what is the maximum power drain on the source?
- For each speaker, determine the impedance seen at the input side of the transformer if each is operating under its full 10 W of power.
- Determine the turns ratio of the transformers.
- At 10 W, what are the speaker voltage and current?
- What is the load seen by the source with one, two, three, or four speakers connected?

**Solutions:**

- Ideally, the primary power equals the power delivered to the load, resulting in a maximum of **40 W** from the supply.
- The power at the primary:

$$P_p = V_p I_p = (70.7 \text{ V}) I_p = 10 \text{ W}$$

and 
$$I_p = \frac{10 \text{ W}}{70.7 \text{ V}} = 141.4 \text{ mA}$$

so that 
$$Z_p = \frac{V_p}{I_p} = \frac{70.7 \text{ V}}{141.4 \text{ mA}} = \mathbf{500 \Omega}$$

c.  $Z_p = a^2 Z_L \Rightarrow a = \sqrt{\frac{Z_p}{Z_L}} = \sqrt{\frac{500 \Omega}{8 \Omega}} = \sqrt{62.5} = \mathbf{7.91 \cong 8 : 1}$

d.  $V_s = V_L = \frac{V_p}{a} = \frac{70.7 \text{ V}}{7.91} = \mathbf{8.94 \text{ V} \cong 9 \text{ V}}$



e. All the speakers are in parallel. Therefore,

$$\text{One speaker: } R_T = 500 \, \Omega$$

$$\text{Two speakers: } R_T = \frac{500 \, \Omega}{2} = 250 \, \Omega$$

$$\text{Three speakers: } R_T = \frac{500 \, \Omega}{3} = 167 \, \Omega$$

$$\text{Four speakers: } R_T = \frac{500 \, \Omega}{4} = 125 \, \Omega$$

Even though the load seen by the source will vary with the number of speakers connected, the source impedance is so low (compared to the lowest load of 125  $\Omega$ ) that the terminal voltage of 70.7 V is essentially constant. This is not the case where the desired result is to match the load to the input impedance; rather, it was to ensure 70.7 V at each primary, no matter how many speakers were connected, and to limit the current drawn from the supply.

The transformer is frequently used to isolate one portion of an electrical system from another. *Isolation* implies the absence of any direct physical connection. As a first example of its use as an isolation device, consider the measurement of line voltages on the order of 40,000 V (Fig. 21.11).

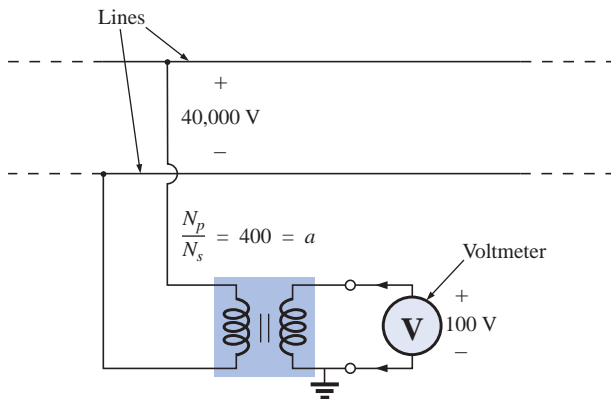


FIG. 21.11

*Isolating a high-voltage line from the point of measurement.*

To apply a voltmeter across 40,000 V would obviously be a dangerous task due to the possibility of physical contact with the lines when making the necessary connections. By including a transformer in the transmission system as original equipment, one can bring the potential down to a safe level for measurement purposes and can determine the line voltage using the turns ratio. Therefore, the transformer will serve both to isolate and to step down the voltage.

As a second example, consider the application of the voltage  $v_x$  to the vertical input of the oscilloscope (a measuring instrument) in Fig. 21.12. If the connections are made as shown, and if the generator and oscilloscope have a common ground, the impedance  $Z_2$  has been effectively shorted out of the circuit by the ground connection of the oscilloscope. The input voltage to the oscilloscope will therefore be mean-

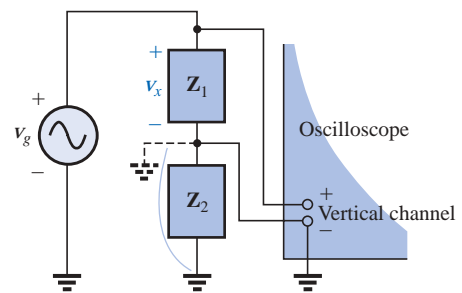
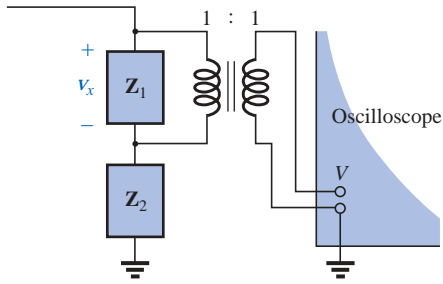


FIG. 21.12

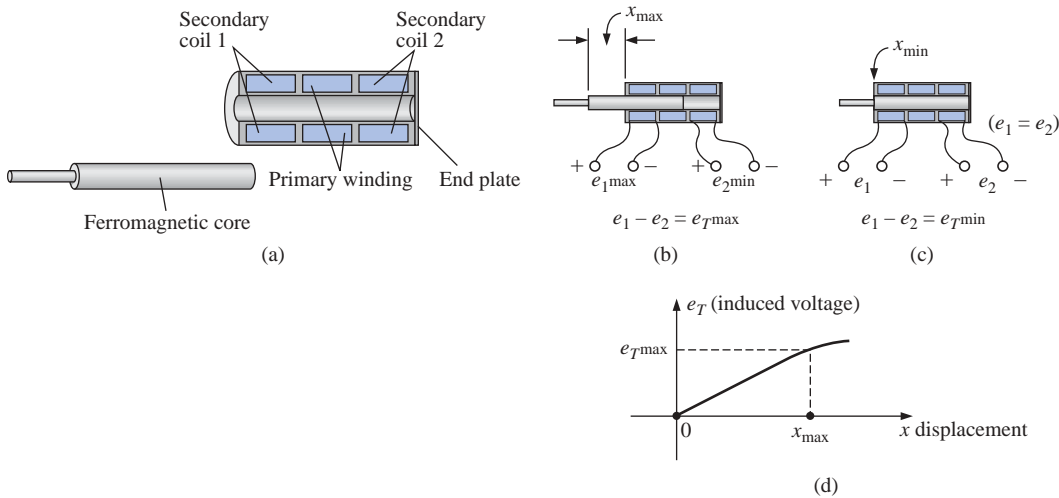
*Demonstrating the shorting effect introduced by the grounded side of the vertical channel of an oscilloscope.*



**FIG. 21.13**  
Correcting the situation of Fig. 21.12 using an isolation transformer.

ingless as far as the voltage  $v_x$  is concerned. In addition, if  $Z_2$  is the current-limiting impedance in the circuit, the current in the circuit may rise to a level that will cause severe damage to the circuit. If a transformer is used as shown in Fig. 21.13, this problem will be eliminated, and the input voltage to the oscilloscope will be  $v_x$ .

The linear variable differential transformer (LVDT) is a sensor that can reveal displacement using transformer effects. In its simplest form, the LVDT has a central winding and two secondary windings, as shown in Fig. 21.14(a). A ferromagnetic core inside the windings is free to move as dictated by some external force. A constant, low-level ac voltage is applied to the primary, and the output voltage is the difference between the voltages induced in the secondaries. If the core is in the position shown in Fig. 21.14(b), a relatively large voltage will be induced across the secondary winding labeled coil 1, and a relatively small voltage will be induced across the secondary winding labeled coil 2 (essentially an air-core transformer for this position). The result is a relatively large secondary output voltage. If the core is in the position shown in Fig. 21.14(c), the flux linking each coil is the same, and the output voltage (being the difference) will be quite small. In total, therefore, the position of the core can be related to the secondary voltage, and a position-versus-voltage graph can be developed as shown in Fig. 21.14(d). Due to the nonlinearity of the  $B$ - $H$  curve, the curve becomes somewhat nonlinear if the core is moved too far out of the unit.



**FIG. 21.14**  
LVDT transformer: (a) construction; (b) maximum displacement; (c) minimum displacement; (d) graph of induced voltage versus displacement.

### 21.6 EQUIVALENT CIRCUIT (IRON-CORE TRANSFORMER)

For the nonideal or practical iron-core transformer, the equivalent circuit appears as in Fig. 21.15. As indicated, part of this equivalent circuit includes an ideal transformer. The remaining elements of Fig. 21.15 are those elements that contribute to the nonideal characteristics of the device. The resistances  $R_p$  and  $R_s$  are simply the dc or geometric resistance of the primary and secondary windings, respectively. For the pri-

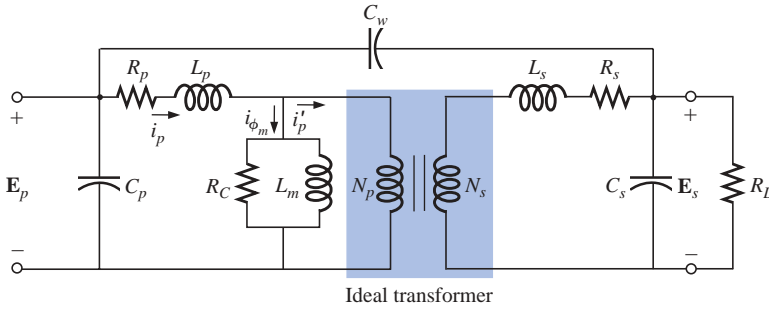


FIG. 21.15

Equivalent circuit for the practical iron-core transformer.

primary and secondary coils of a transformer, there is a small amount of flux that links each coil but does not pass through the core, as shown in Fig. 21.16 for the primary winding. This **leakage flux**, representing a definite loss in the system, is represented by an inductance  $L_p$  in the primary circuit and an inductance  $L_s$  in the secondary.

The resistance  $R_c$  represents the hysteresis and eddy current losses (core losses) within the core due to an ac flux through the core. The inductance  $L_m$  (magnetizing inductance) is the inductance associated with the magnetization of the core, that is, the establishing of the flux  $\Phi_m$  in the core. The capacitances  $C_p$  and  $C_s$  are the lumped capacitances of the primary and secondary circuits, respectively, and  $C_w$  represents the equivalent lumped capacitances between the windings of the transformer.

Since  $i'_p$  is normally considerably larger than  $i_{\phi_m}$  (the magnetizing current), we will ignore  $i_{\phi_m}$  for the moment (set it equal to zero), resulting in the absence of  $R_c$  and  $L_m$  in the reduced equivalent circuit of Fig. 21.17. The capacitances  $C_p$ ,  $C_w$ , and  $C_s$  do not appear in the equivalent circuit of Fig. 21.17 since their reactance at typical operating frequencies will not appreciably affect the transfer characteristics of the transformer.

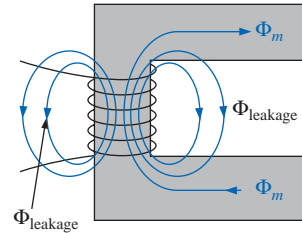


FIG. 21.16

Identifying the leakage flux of the primary.

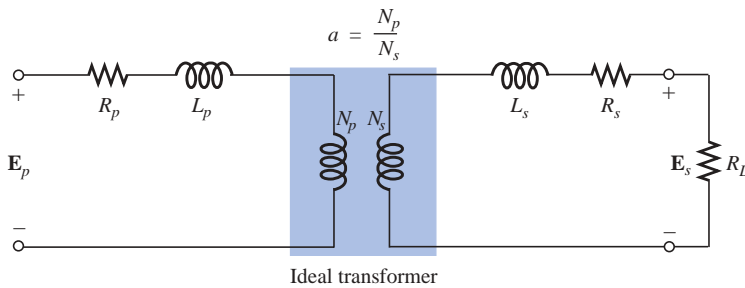
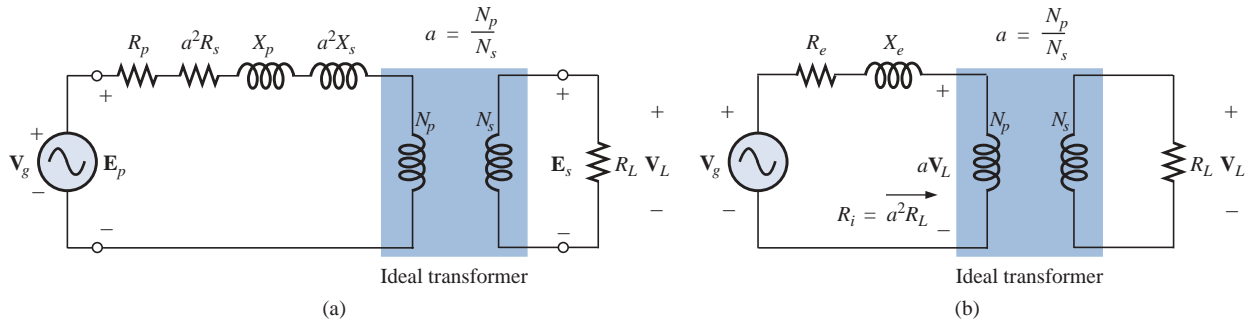


FIG. 21.17

Reduced equivalent circuit for the nonideal iron-core transformer.

If we now reflect the secondary circuit through the ideal transformer using Eq. (21.19), as shown in Fig. 21.18(a), we will have the load and generator voltage in the same continuous circuit. The total resistance and inductive reactance of the primary circuit are determined by

$$R_{\text{equivalent}} = R_e = R_p + a^2 R_s \quad (21.22)$$



**FIG. 21.18**  
Reflecting the secondary circuit into the primary side of the iron-core transformer.

and

$$X_{\text{equivalent}} = X_e = X_p + a^2 X_s \tag{21.23}$$

which result in the useful equivalent circuit of Fig. 21.18(b). The load voltage can be obtained directly from the circuit of Fig. 21.18(b) through the voltage divider rule:

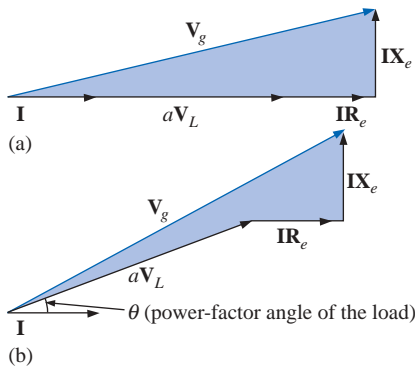
$$aV_L = \frac{(R_i)V_g}{(R_e + R_i) + jX_e}$$

and

$$V_L = \frac{a^2 R_L V_g}{(R_e + a^2 R_L) + jX_e} \tag{21.24}$$

The network of Fig. 21.18(b) will also allow us to calculate the generator voltage necessary to establish a particular load voltage. The voltages across the elements of Fig. 21.18(b) have the phasor relationship indicated in Fig. 21.19(a). Note that the current is the reference phasor for drawing the phasor diagram. That is, the voltages across the resistive elements are *in phase* with the current phasor, while the voltage across the equivalent inductance leads the current by 90°. The primary voltage, by Kirchhoff's voltage law, is then the phasor sum of these voltages, as indicated in Fig. 21.19(a). For an inductive load, the phasor diagram appears in Fig. 21.19(b). Note that  $aV_L$  leads  $I$  by the power-factor angle of the load. The remainder of the diagram is then similar to that for a resistive load. (The phasor diagram for a capacitive load will be left to the reader as an exercise.)

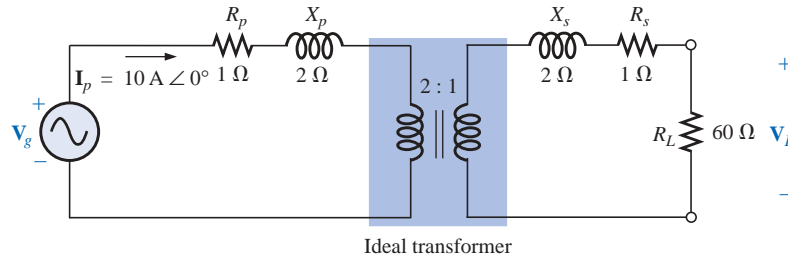
The effect of  $R_e$  and  $X_e$  on the magnitude of  $V_g$  for a particular  $V_L$  is obvious from Eq. (21.24) or Fig. 21.19. For increased values of  $R_e$  or  $X_e$ , an increase in  $V_g$  is required for the same load voltage. For  $R_e$  and  $X_e = 0$ ,  $V_L$  and  $V_g$  are simply related by the turns ratio.



**FIG. 21.19**  
Phasor diagram for the iron-core transformer with (a) unity power-factor load (resistive) and (b) lagging power-factor load (inductive).

**EXAMPLE 21.7** For a transformer having the equivalent circuit of Fig. 21.20:

- Determine  $R_e$  and  $X_e$ .
- Determine the magnitude of the voltages  $V_L$  and  $V_g$ .
- Determine the magnitude of the voltage  $V_g$  to establish the same load voltage in part (b) if  $R_e$  and  $X_e = 0 \Omega$ . Compare with the result of part (b).



**FIG. 21.20**  
Example 21.7.

**Solutions:**

- a.  $R_e = R_p + a^2R_s = 1 \Omega + (2)^2(1 \Omega) = 5 \Omega$   
 $X_e = X_p + a^2X_s = 2 \Omega + (2)^2(2 \Omega) = 10 \Omega$
- b. The transformed equivalent circuit appears in Fig. 21.21.

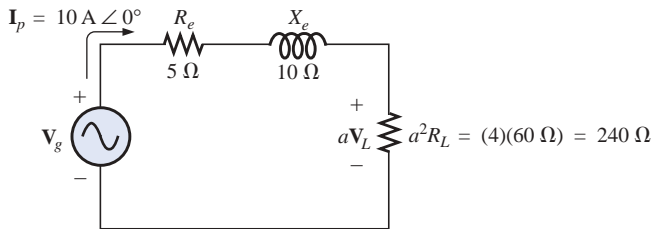
$$aV_L = (I_p)(a^2R_L) = 2400 \text{ V}$$

Thus,

$$V_L = \frac{2400 \text{ V}}{a} = \frac{2400 \text{ V}}{2} = 1200 \text{ V}$$

and

$$\begin{aligned} V_g &= I_p(R_e + a^2R_L + j X_e) \\ &= 10 \text{ A}(5 \Omega + 240 \Omega + j 10 \Omega) = 10 \text{ A}(245 \Omega + j 10 \Omega) \\ V_g &= 2450 \text{ V} + j 100 \text{ V} = 2452.04 \text{ V} \angle 2.34^\circ = \mathbf{2452.04 \text{ V} \angle 2.34^\circ} \end{aligned}$$



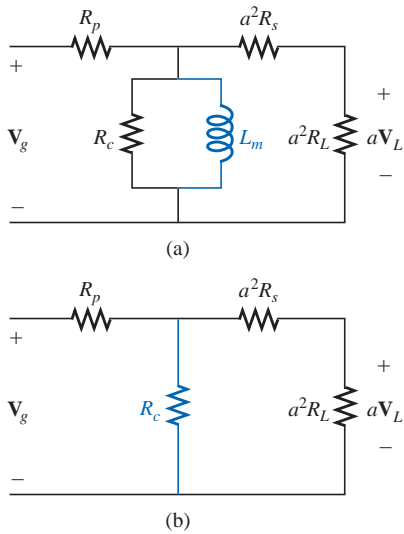
**FIG. 21.21**  
Transformed equivalent circuit of Fig. 21.20.

- c. For  $R_e$  and  $X_e = 0$ ,  $V_g = aV_L = (2)(1200 \text{ V}) = 2400 \text{ V}$ .  
 Therefore, it is necessary to increase the generator voltage by 52.04 V (due to  $R_e$  and  $X_e$ ) to obtain the same load voltage.

## 21.7 FREQUENCY CONSIDERATIONS

For certain frequency ranges, the effect of some parameters in the equivalent circuit of the iron-core transformer of Fig. 21.15 should not be ignored. Since it is convenient to consider a low-, mid-, and high-frequency region, the equivalent circuits for each will now be introduced and briefly examined.

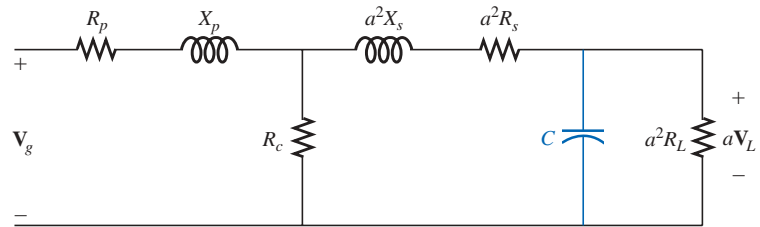
For the low-frequency region, the series reactance ( $2\pi fL$ ) of the primary and secondary leakage reactances can be ignored since they are



**FIG. 21.22**  
 (a) Low-frequency reflected equivalent circuit;  
 (b) mid-frequency reflected circuit.

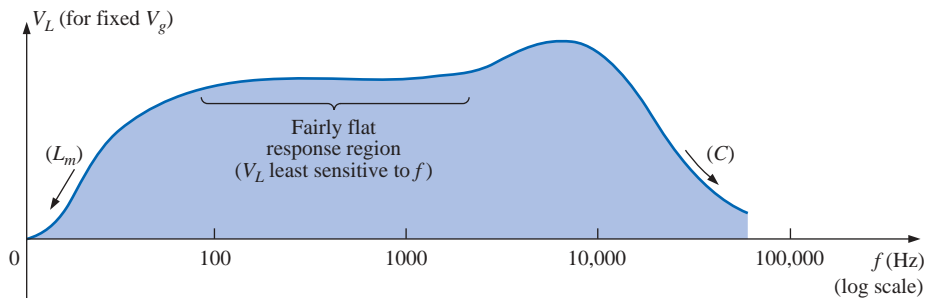
small in magnitude. The magnetizing inductance must be included, however, since it appears in parallel with the secondary reflected circuit, and small impedances in a parallel network can have a dramatic impact on the terminal characteristics. The resulting equivalent network for the low-frequency region is provided in Fig. 21.22(a). As the frequency decreases, the reactance of the magnetizing inductance will reduce in magnitude, causing a reduction in the voltage across the secondary circuit. For  $f = 0$  Hz,  $L_m$  is ideally a short circuit, and  $V_L = 0$ . As the frequency increases, the reactance of  $L_m$  will eventually be sufficiently large compared with the reflected secondary impedance to be neglected. The mid-frequency reflected equivalent circuit will then appear as shown in Fig. 21.22(b). Note the absence of reactive elements, resulting in an *in-phase* relationship between load and generator voltages.

For higher frequencies, the capacitive elements and primary and secondary leakage reactances must be considered, as shown in Fig. 21.23. For discussion purposes, the effects of  $C_w$  and  $C_s$  appear as a lumped capacitor  $C$  in the reflected network of Fig. 21.23;  $C_p$  does not appear since the effect of  $C$  will predominate. As the frequency of interest increases, the capacitive reactance ( $X_C = 1/2\pi fC$ ) will decrease to the point that it will have a shorting effect across the secondary circuit of the transformer, causing  $V_L$  to decrease in magnitude.



**FIG. 21.23**  
 High-frequency reflected equivalent circuit.

A typical iron-core transformer-frequency response curve appears in Fig. 21.24. For the low- and high-frequency regions, the primary element responsible for the drop-off is indicated. The peaking that occurs in the high-frequency region is due to the series resonant circuit established by the inductive and capacitive elements of the equivalent circuit. In the peaking region, the series resonant circuit is in, or near, its resonant or tuned state.



**FIG. 21.24**  
 Transformer-frequency response curve.



## 21.8 SERIES CONNECTION OF MUTUALLY COUPLED COILS

In Chapter 12, we found that the total inductance of series isolated coils was determined simply by the sum of the inductances. For two coils that are connected in series but also share the same flux linkages, such as those in Fig. 21.25(a), a mutual term is introduced that will alter the total inductance of the series combination. The physical picture of how the coils are connected is indicated in Fig. 21.25(b). An iron core is included, although the equations to be developed are for any two mutually coupled coils with any value of coefficient of coupling  $k$ . When referring to the voltage induced across the inductance  $L_1$  (or  $L_2$ ) due to the change in flux linkages of the inductance  $L_2$  (or  $L_1$ , respectively), the mutual inductance is represented by  $M_{12}$ . This type of subscript notation is particularly important when there are two or more mutual terms.

Due to the presence of the mutual term, the induced voltage  $e_1$  is composed of that due to the self-inductance  $L_1$  and that due to the mutual inductance  $M_{12}$ . That is,

$$e_1 = L_1 \frac{di_1}{dt} + M_{12} \frac{di_2}{dt}$$

However, since  $i_1 = i_2 = i$ ,

$$e_1 = L_1 \frac{di}{dt} + M_{12} \frac{di}{dt}$$

or  $e_1 = (L_1 + M_{12}) \frac{di}{dt}$  (volts, V) **(21.25)**

and, similarly,

$e_2 = (L_2 + M_{12}) \frac{di}{dt}$  (volts, V) **(21.26)**

For the series connection, the total induced voltage across the series coils, represented by  $e_T$ , is

$$e_T = e_1 + e_2 = (L_1 + M_{12}) \frac{di}{dt} + (L_2 + M_{12}) \frac{di}{dt}$$

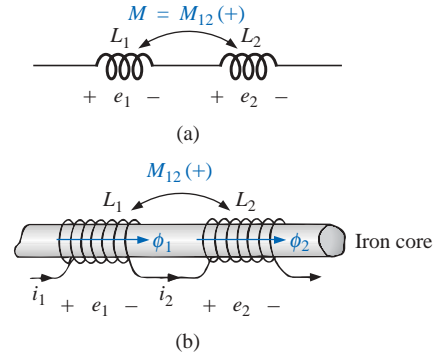
or 
$$e_T = (L_1 + L_2 + M_{12} + M_{12}) \frac{di}{dt}$$

and the total effective inductance is

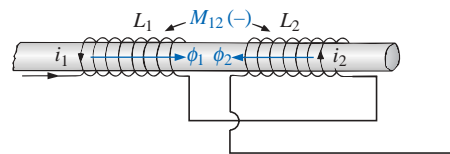
$L_{T(+)} = L_1 + L_2 + 2M_{12}$  (henries, H) **(21.27)**

The subscript (+) was included to indicate that the mutual terms have a positive sign and are added to the self-inductance values to determine the total inductance. If the coils were wound such as shown in Fig. 21.26, where  $\phi_1$  and  $\phi_2$  are in opposition, the induced voltages due to the mutual terms would oppose that due to the self-inductance, and the total inductance would be determined by

$L_{T(-)} = L_1 + L_2 - 2M_{12}$  (henries, H) **(21.28)**



**FIG. 21.25**  
Mutually coupled coils connected in series.



**FIG. 21.26**  
Mutually coupled coils connected in series with negative mutual inductance.

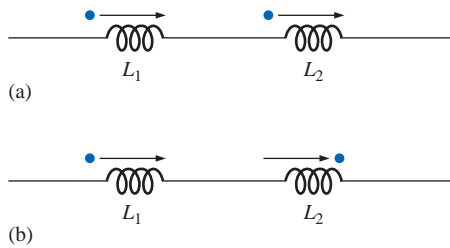


Through Eqs. (21.27) and (21.28), the mutual inductance can be determined by

$$M_{12} = \frac{1}{4}(L_{T(+)} - L_{T(-)}) \tag{21.29}$$

Equation (21.29) is very effective in determining the mutual inductance between two coils. It states that the mutual inductance is equal to one-quarter the difference between the total inductance with a positive and negative mutual effect.

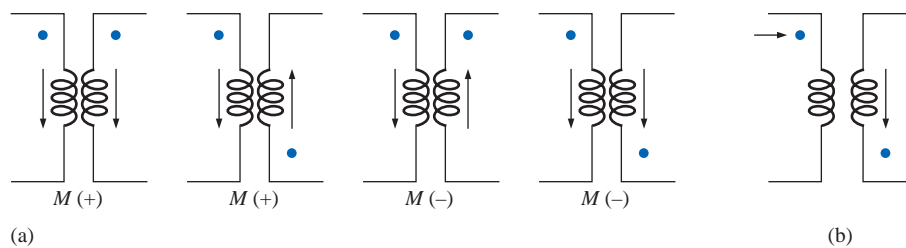
From the preceding, it should be clear that the mutual inductance will directly affect the magnitude of the voltage induced across a coil since it will determine the net inductance of the coil. Additional examination reveals that the sign of the mutual term for each coil of a coupled pair is the same. For  $L_{T(+)}$  they were both positive, and for  $L_{T(-)}$  they were both negative. On a network schematic where it is inconvenient to indicate the windings and the flux path, a system of dots is employed that will determine whether the mutual terms are to be positive or negative. The dot convention is shown in Fig. 21.27 for the series coils of Figs. 21.25 and 21.26.



**FIG. 21.27**  
Dot convention for the series coils of  
(a) Fig. 21.25 and (b) Fig. 21.26.

If the current through *each* of the mutually coupled coils is going away from (or toward) the dot as it *passes through the coil*, the mutual term will be positive, as shown for the case in Fig. 21.27(a). If the arrow indicating current direction through the coil is leaving the dot for one coil and entering the dot for the other, the mutual term is negative.

A few possibilities for mutually coupled transformer coils are indicated in Fig. 21.28(a). The sign of  $M$  is indicated for each. When determining the sign, be sure to examine the current direction within the coil itself. In Fig. 21.28(b), one direction was indicated outside for one coil and through for the other. It initially might appear that the sign should be positive since both currents enter the dot, but the current *through* coil 1 is leaving the dot; hence a negative sign is in order.



**FIG. 21.28**  
Defining the sign of  $M$  for mutually coupled transformer coils.

The dot convention also reveals the polarity of the *induced* voltage across the mutually coupled coil. If the reference direction for the current *in* a coil leaves the dot, the polarity at the dot for the induced voltage of the mutually coupled coil is positive. In the first two figures of Fig. 21.28(a), the polarity at the dots of the induced voltages is positive. In the third figure of Fig. 21.28(a), the polarity at the dot of the right-hand coil is negative, while the polarity at the dot of the left-hand coil is positive, since the current enters the dot (within the coil) of the right-hand coil. The comments for the third figure of Fig. 21.28(a) can also be applied to the last figure of Fig. 21.28(a).



**EXAMPLE 21.8** Find the total inductance of the series coils of Fig. 21.29.

**Solution:**

Current vectors leave dot.

Coil 1:  $L_1 + M_{12} - M_{13}$

One current vector enters dot, while one leaves.

Coil 2:  $L_2 + M_{12} - M_{23}$

Coil 3:  $L_3 - M_{23} - M_{13}$

and

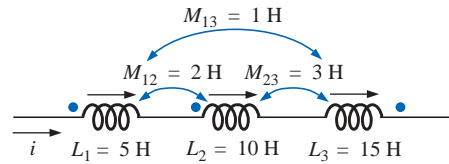
$$L_T = (L_1 + M_{12} - M_{13}) + (L_2 + M_{12} - M_{23}) + (L_3 - M_{23} - M_{13})$$

$$= L_1 + L_2 + L_3 + 2M_{12} - 2M_{23} - 2M_{13}$$

Substituting values, we find

$$L_T = 5 \text{ H} + 10 \text{ H} + 15 \text{ H} + 2(2 \text{ H}) - 2(3 \text{ H}) - 2(1 \text{ H})$$

$$= 34 \text{ H} - 8 \text{ H} = \mathbf{26 \text{ H}}$$



**FIG. 21.29**  
Example 21.8.

**EXAMPLE 21.9** Write the mesh equations for the transformer network in Fig. 21.30.

**Solution:** For each coil, the mutual term is positive, and the sign of  $M$  in  $\mathbf{X}_m = \omega M \angle 90^\circ$  is positive, as determined by the direction of  $\mathbf{I}_1$  and  $\mathbf{I}_2$ . Thus,

$$\mathbf{E}_1 - \mathbf{I}_1 R_1 - \mathbf{I}_1 X_{L_1} \angle 90^\circ - \mathbf{I}_2 X_m \angle 90^\circ = 0$$

or

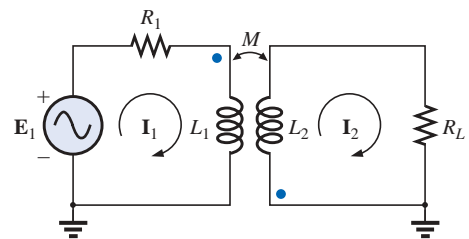
$$\mathbf{E}_1 - \mathbf{I}_1(R_1 + j X_{L_1}) - \mathbf{I}_2 X_m \angle 90^\circ = 0$$

For the other loop,

$$-\mathbf{I}_2 X_{L_2} \angle 90^\circ - \mathbf{I}_1 X_m \angle 90^\circ - \mathbf{I}_2 R_L = 0$$

or

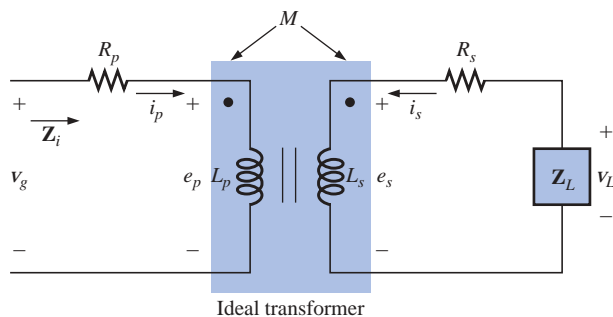
$$\mathbf{I}_2(R_L + j X_{L_2}) + \mathbf{I}_1 X_m \angle 90^\circ = 0$$



**FIG. 21.30**  
Example 21.9.

## 21.9 AIR-CORE TRANSFORMER

As the name implies, the air-core transformer does not have a ferromagnetic core to link the primary and secondary coils. Rather, the coils are placed sufficiently close to have a mutual inductance that will establish the desired transformer action. In Fig. 21.31, current direction and



**FIG. 21.31**  
Air-core transformer equivalent circuit.



polarities have been defined for the air-core transformer. Note the presence of a mutual inductance term  $M$ , which will be positive in this case, as determined by the dot convention.

From past analysis in this chapter, we now know that

$$e_p = L_p \frac{di_p}{dt} + M \frac{di_s}{dt} \quad (21.30)$$

for the primary circuit.

We found in Chapter 12 that for the pure inductor, with no mutual inductance present, the mathematical relationship

$$v_1 = L \frac{di_1}{dt}$$

resulted in the following useful form of the voltage across an inductor:

$$\mathbf{V}_1 = \mathbf{I}_1 X_L \angle 90^\circ \quad \text{where } X_L = \omega L$$

Similarly, it can be shown, for a mutual inductance, that

$$v_1 = M \frac{di_2}{dt}$$

will result in

$$\mathbf{V}_1 = \mathbf{I}_2 X_m \angle 90^\circ \quad \text{where } X_m = \omega M \quad (21.31)$$

Equation (21.30) can then be written (using phasor notation) as

$$\mathbf{E}_p = \mathbf{I}_p X_{L_p} \angle 90^\circ + \mathbf{I}_s X_m \angle 90^\circ \quad (21.32)$$

and 
$$\mathbf{V}_g = \mathbf{I}_p R_p \angle 0^\circ + \mathbf{I}_p X_{L_p} \angle 90^\circ + \mathbf{I}_s X_m \angle 90^\circ$$

or 
$$\mathbf{V}_g = \mathbf{I}_p (R_p + j X_{L_p}) + \mathbf{I}_s X_m \angle 90^\circ \quad (21.33)$$

For the secondary circuit,

$$\mathbf{E}_s = \mathbf{I}_s X_{L_s} \angle 90^\circ + \mathbf{I}_p X_m \angle 90^\circ \quad (21.34)$$

and 
$$\mathbf{V}_L = \mathbf{I}_s R_s \angle 0^\circ + \mathbf{I}_s X_{L_s} \angle 90^\circ + \mathbf{I}_p X_m \angle 90^\circ$$

or 
$$\mathbf{V}_L = \mathbf{I}_s (R_s + j X_{L_s}) + \mathbf{I}_p X_m \angle 90^\circ \quad (21.35)$$

Substituting 
$$\mathbf{V}_L = -\mathbf{I}_s \mathbf{Z}_L$$

into Eq. (21.35) results in

$$0 = \mathbf{I}_s (R_s + j X_{L_s} + \mathbf{Z}_L) + \mathbf{I}_p X_m \angle 90^\circ$$

Solving for  $\mathbf{I}_s$ , we have

$$\mathbf{I}_s = \frac{-\mathbf{I}_p X_m \angle 90^\circ}{R_s + j X_{L_s} + \mathbf{Z}_L}$$

and, substituting into Eq. (21.33), we obtain



$$\mathbf{V}_g = \mathbf{I}_p(R_p + jX_{L_p}) + \left( \frac{-\mathbf{I}_p X_m \angle 90^\circ}{R_s + jX_{L_s} + \mathbf{Z}_L} \right) X_m \angle 90^\circ$$

Thus, the input impedance is

$$\mathbf{Z}_i = \frac{\mathbf{V}_g}{\mathbf{I}_p} = R_p + jX_{L_p} - \frac{(X_m \angle 90^\circ)^2}{R_s + jX_{L_s} + \mathbf{Z}_L}$$

or, defining

$$\mathbf{Z}_p = R_p + jX_{L_p} \quad \mathbf{Z}_s = R_s + jX_{L_s} \quad \text{and} \quad X_m \angle 90^\circ = +j\omega M$$

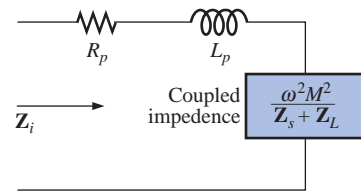
we have

$$\mathbf{Z}_i = \mathbf{Z}_p - \frac{(+j\omega M)^2}{\mathbf{Z}_s + \mathbf{Z}_L}$$

and

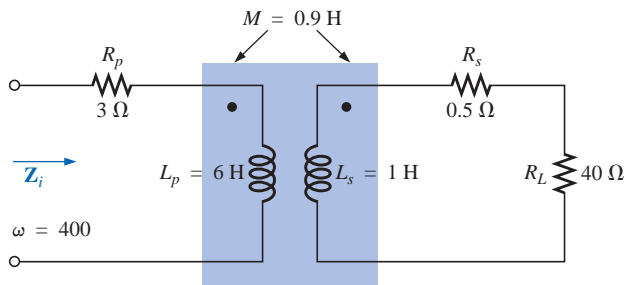
$$\mathbf{Z}_i = \mathbf{Z}_p - \frac{(\omega M)^2}{\mathbf{Z}_s + \mathbf{Z}_L} \quad (21.36)$$

The term  $(\omega M)^2/(\mathbf{Z}_s + \mathbf{Z}_L)$  is called the *coupled impedance*, and it is independent of the sign of  $M$  since it is squared in the equation. Consider also that since  $(\omega M)^2$  is a constant with  $0^\circ$  phase angle, if the load  $\mathbf{Z}_L$  is resistive, the resulting coupled impedance term will appear capacitive due to division of  $(\mathbf{Z}_s + R_L)$  into  $(\omega M)^2$ . This resulting capacitive reactance will oppose the series primary inductance  $L_p$ , causing a reduction in  $\mathbf{Z}_i$ . Including the effect of the mutual term, the input impedance to the network will appear as shown in Fig. 21.32.



**FIG. 21.32**  
Input characteristics for the air-core transformer.

**EXAMPLE 21.10** Determine the input impedance to the air-core transformer in Fig. 21.33.



**FIG. 21.33**  
Example 21.10.

**Solution:**

$$\begin{aligned} \mathbf{Z}_i &= \mathbf{Z}_p + \frac{(\omega M)^2}{\mathbf{Z}_s + \mathbf{Z}_L} \\ &= R_p + jX_{L_p} + \frac{(\omega M)^2}{R_s + jX_{L_s} + R_L} \\ &= 3 \Omega + j2.4 \text{ k}\Omega + \frac{((400 \text{ rad/s})(0.9 \text{ H}))^2}{0.5 \Omega + j400 \Omega + 40 \Omega} \\ &\cong j2.4 \text{ k}\Omega + \frac{129.6 \times 10^3 \Omega}{40.5 + j400} \end{aligned}$$



$$\begin{aligned}
 &= j 2.4 \text{ k}\Omega + \underbrace{322.4 \text{ }\Omega \angle -84.22^\circ}_{\text{capacitive}} \\
 &= j 2.4 \text{ k}\Omega + (0.0325 \text{ k}\Omega - j 0.3208 \text{ k}\Omega) \\
 &= 0.0325 \text{ k}\Omega + j (2.40 - 0.3208) \text{ k}\Omega
 \end{aligned}$$

and  $Z_i = R_i + j X_{L_i} = 32.5 \text{ }\Omega + j 2079 \text{ }\Omega = 2079.25 \text{ }\Omega \angle 89.10^\circ$

### 21.10 NAMEPLATE DATA

A typical iron-core power transformer rating, included in the **nameplate data** for the transformer, might be the following:

$$5 \text{ kVA} \quad 2000/100 \text{ V} \quad 60 \text{ Hz}$$

The 2000 V or the 100 V can be either the primary or the secondary voltage; that is, if 2000 V is the primary voltage, then 100 V is the secondary voltage, and vice versa. The 5 kVA is the apparent power ( $S = VI$ ) rating of the transformer. If the secondary voltage is 100 V, then the maximum load current is

$$I_L = \frac{S}{V_L} = \frac{5000 \text{ VA}}{100 \text{ V}} = 50 \text{ A}$$

and if the secondary voltage is 2000 V, then the maximum load current is

$$I_L = \frac{S}{V_L} = \frac{5000 \text{ VA}}{2000 \text{ V}} = 2.5 \text{ A}$$

The transformer is rated in terms of the apparent power rather than the average, or real, power for the reason demonstrated by the circuit of Fig. 21.34. Since the current through the load is greater than that determined by the apparent power rating, the transformer may be permanently damaged. Note, however, that since the load is purely capacitive, the average power to the load is zero. The wattage rating would therefore be meaningless regarding the ability of this load to damage the transformer.

The transformation ratio of the transformer under discussion can be either of two values. If the secondary voltage is 2000 V, the transformation ratio is  $a = N_p/N_s = V_g/V_L = 100 \text{ V}/2000 \text{ V} = 1/20$ , and the transformer is a step-up transformer. If the secondary voltage is 100 V, the transformation ratio is  $a = N_p/N_s = V_g/V_L = 2000 \text{ V}/100 \text{ V} = 20$ , and the transformer is a step-down transformer.

The rated primary current can be determined simply by applying Eq. (21.18):

$$I_p = \frac{I_s}{a}$$

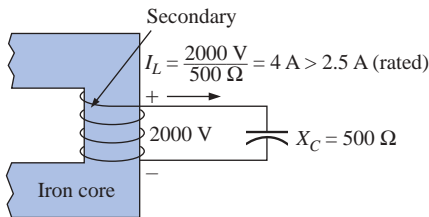
which is equal to  $[2.5 \text{ A}/(1/20)] = 50 \text{ A}$  if the secondary voltage is 2000 V, and  $(50 \text{ A}/20) = 2.5 \text{ A}$  if the secondary voltage is 100 V.

To explain the necessity for including the frequency in the nameplate data, consider Eq. (21.12):

$$E_p = 4.44 f_p N_p \Phi_m$$

and the  $B$ - $H$  curve for the iron core of the transformer (Fig. 21.35).

The point of operation on the  $B$ - $H$  curve for most transformers is at the knee of the curve. If the frequency of the applied signal should



**FIG. 21.34**

*Demonstrating why transformers are rated in kVA rather than kW.*

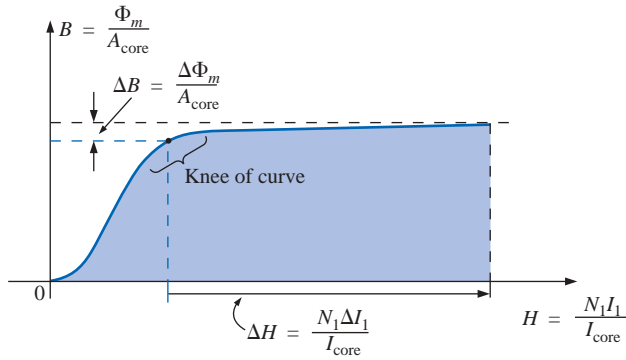


FIG. 21.35

Demonstrating why the frequency of application is important for transformers.

drop, and  $N_p$  and  $E_p$  remain the same, then  $\Phi_m$  must increase in magnitude, as determined by Eq. (21.12):

$$\Phi_m \uparrow = \frac{E_p}{4.44 f_p \downarrow N_p}$$

The result is that  $B$  will increase, as shown in Fig. 21.35, causing  $H$  to increase also. The resulting  $\Delta I$  could cause a very high current in the primary, resulting in possible damage to the transformer.

### 21.11 TYPES OF TRANSFORMERS

Transformers are available in many different shapes and sizes. Some of the more common types include the power transformer, audio transformer, IF (intermediate-frequency) transformer, and RF (radio-frequency) transformer. Each is designed to fulfill a particular requirement in a specific area of application. The symbols for some of the basic types of transformers are shown in Fig. 21.36.

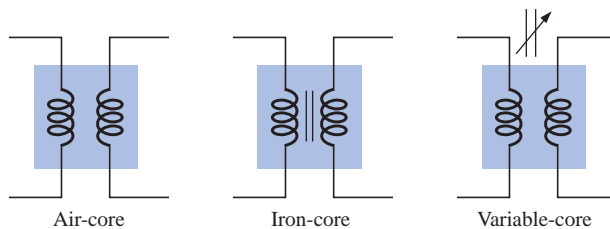
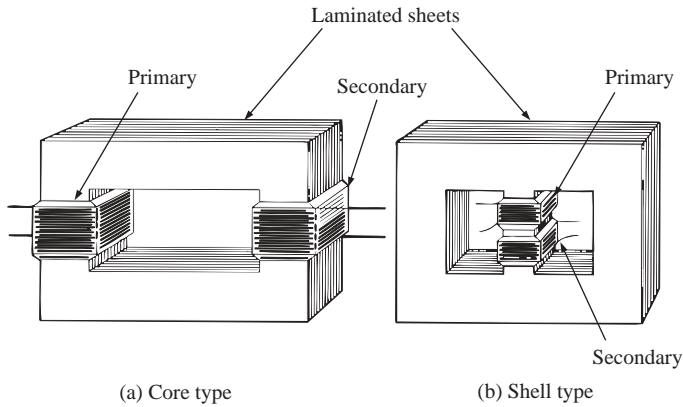


FIG. 21.36

Transformer symbols.

The method of construction varies from one transformer to another. Two of the many different ways in which the primary and secondary coils can be wound around an iron core are shown in Fig. 21.37. In either case, the core is made of laminated sheets of ferromagnetic material separated by an insulator to reduce the eddy current losses. The sheets themselves will also contain a small percentage of silicon to increase the electrical resistivity of the material and further reduce the eddy current losses.

A variation of the core-type transformer appears in Fig. 21.38. This transformer is designed for low-profile (the 2.5-VA size has a maximum

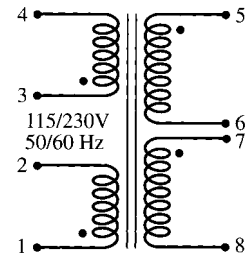


(a) Core type

(b) Shell type

**FIG. 21.37**

*Types of ferromagnetic core construction.*

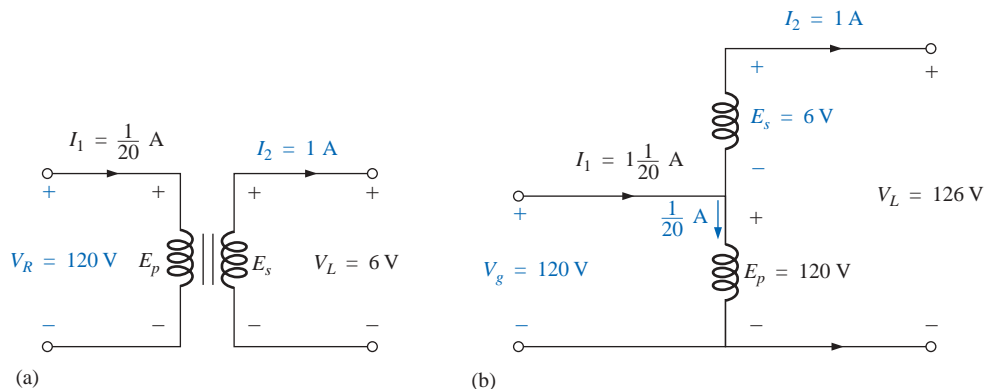


**FIG. 21.38**

*Split bobbin, low-profile power transformer. (Courtesy of Microtran Company, Inc.)*

height of only 0.65 in.) applications in power, control, and instrumentation applications. There are actually two transformers on the same core, with the primary and secondary of each wound side by side. The schematic representation appears in the same figure. Each set of terminals on the left can accept 115 V at 50 or 60 Hz, whereas each side of the output will provide 230 V at the same frequency. Note the dot convention, as described earlier in the chapter.

The **autotransformer** [Fig. 21.39(b)] is a type of power transformer that, instead of employing the two-circuit principle (complete isolation between coils), has one winding common to both the input and the output circuits. The induced voltages are related to the turns ratio in the same manner as that described for the two-circuit transformer. If the proper connection is used, a two-circuit power transformer can be



(a)

(b)

**FIG. 21.39**

*(a) Two-circuit transformer; (b) autotransformer.*

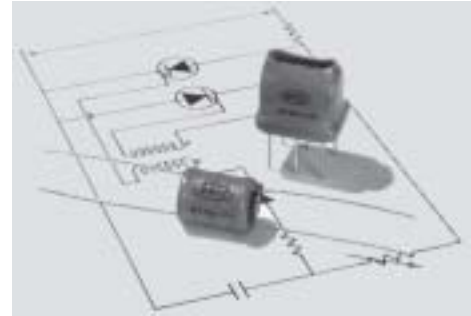


employed as an autotransformer. The advantage of using it as an autotransformer is that a larger apparent power can be transformed. This can be demonstrated by the two-circuit transformer of Fig. 21.39(a), shown in Fig. 21.39(b) as an autotransformer.

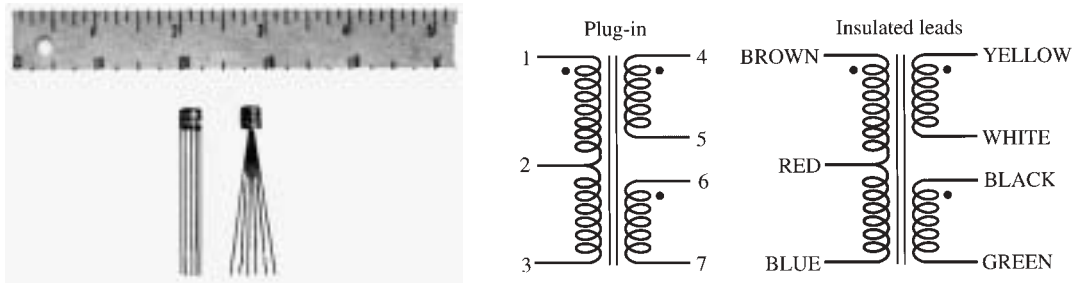
For the two-circuit transformer, note that  $S = (\frac{1}{20} \text{ A})(120 \text{ V}) = 6 \text{ VA}$ , whereas for the autotransformer,  $S = (1\frac{1}{20} \text{ A})(120 \text{ V}) = 126 \text{ VA}$ , which is many times that of the two-circuit transformer. Note also that the current and voltage of each coil are the same as those for the two-circuit configuration. The disadvantage of the autotransformer is obvious: loss of the isolation between the primary and secondary circuits.

A pulse transformer designed for printed-circuit applications where high-amplitude, long-duration pulses must be transferred without saturation appears in Fig. 21.40. Turns ratios are available from 1 : 1 to 5 : 1 at maximum line voltages of 240 V rms at 60 Hz. The upper unit is for printed-circuit applications with isolated dual primaries, whereas the lower unit is the bobbin variety with a single primary winding.

Two miniature ( $\frac{1}{4}$  in. by  $\frac{1}{4}$  in.) transformers with plug-in or insulated leads appear in Fig. 21.41, along with their schematic representations. Power ratings of 100 mW or 125 mW are available with a variety of turns ratios, such as 1 : 1, 5 : 1, 9.68 : 1, and 25 : 1.



**FIG. 21.40**  
Pulse transformers. (Courtesy of DALE Electronics, Inc.)

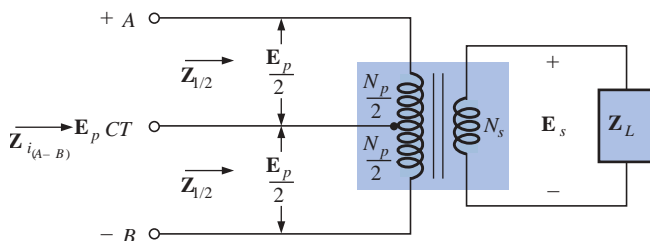


**FIG. 21.41**  
Miniature transformers. (Courtesy of PICO Electronics, Inc.)

### 21.12 TAPPED AND MULTIPLE-LOAD TRANSFORMERS

For the **center-tapped** (primary) **transformer** of Fig. 21.42, where the voltage from the center tap to either outside lead is defined as  $E_p/2$ , the relationship between  $E_p$  and  $E_s$  is

$$\frac{E_p}{E_s} = \frac{N_p}{N_s} \tag{21.37}$$



**FIG. 21.42**  
Ideal transformer with a center-tapped primary.



For each half-section of the primary,

$$Z_{1/2} = \left(\frac{N_p/2}{N_s}\right)^2 Z_L = \frac{1}{4} \left(\frac{N_p}{N_s}\right)^2 Z_L$$

with  $Z_{i(A-B)} = \left(\frac{N_p}{N_s}\right)^2 Z_L$

Therefore,

$$Z_{1/2} = \frac{1}{4} Z_i \tag{21.38}$$

For the **multiple-load transformer** of Fig. 21.43, the following equations apply:

$$\frac{E_i}{E_2} = \frac{N_1}{N_2} \quad \frac{E_1}{E_3} = \frac{N_1}{N_3} \quad \frac{E_2}{E_3} = \frac{N_2}{N_3} \tag{21.39}$$

The total input impedance can be determined by first noting that, for the ideal transformer, the power delivered to the primary is equal to the power dissipated by the load; that is,

$$P_1 = P_{L_2} + P_{L_3}$$

and, for resistive loads ( $Z_i = R_i$ ,  $Z_2 = R_2$ , and  $Z_3 = R_3$ ),

$$\frac{E_i^2}{R_i} = \frac{E_2^2}{R_2} + \frac{E_3^2}{R_3}$$

or, since

$$E_2 = \frac{N_2}{N_1} E_i \quad \text{and} \quad E_3 = \frac{N_3}{N_1} E_i$$

then

$$\frac{E_i^2}{R_i} = \frac{[(N_2/N_1)E_i]^2}{R_2} + \frac{[(N_3/N_1)E_i]^2}{R_3}$$

and

$$\frac{E_i^2}{R_i} = \frac{E_i^2}{(N_1/N_2)^2 R_2} + \frac{E_i^2}{(N_1/N_3)^2 R_3}$$

Thus,

$$\frac{1}{R_i} = \frac{1}{(N_1/N_2)^2 R_2} + \frac{1}{(N_1/N_3)^2 R_3} \tag{21.40}$$

indicating that the load resistances are reflected in parallel.

For the configuration of Fig. 21.44, with  $E_2$  and  $E_3$  defined as shown, Equations (21.39) and (21.40) are applicable.

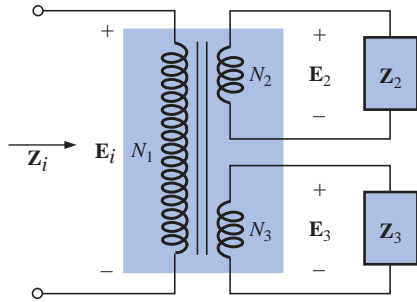


FIG. 21.43

Ideal transformer with multiple loads.

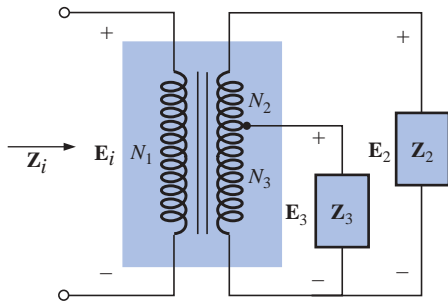


FIG. 21.44

Ideal transformer with a tapped secondary and multiple loads.

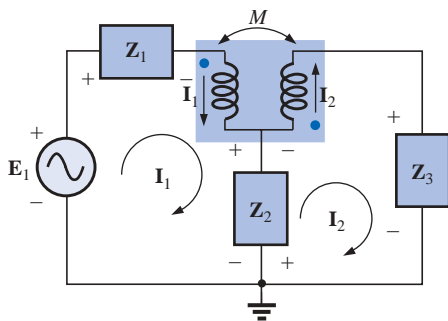


FIG. 21.45

Applying mesh analysis to magnetically coupled coils.

### 21.13 NETWORKS WITH MAGNETICALLY COUPLED COILS

For multiloop networks with magnetically coupled coils, the mesh-analysis approach is most frequently applied. A firm understanding of the dot convention discussed earlier should make the writing of the equations quite direct and free of errors. Before writing the equations for any particular loop, first determine whether the mutual term is positive or negative, keeping in mind that it will have the same sign as that for the other magnetically coupled coil. For the two-loop network of Fig. 21.45, for example, the mutual term has a positive sign since the current through each coil leaves the dot. For the primary loop,

$$E_1 - I_1 Z_1 - I_1 Z_{L_1} - I_2 Z_m - Z_2(I_1 - I_2) = 0$$



where  $M$  of  $\mathbf{Z}_m = \omega M \angle 90^\circ$  is positive, and

$$\mathbf{I}_1(\mathbf{Z}_1 + \mathbf{Z}_{L_1} + \mathbf{Z}_2) - \mathbf{I}_2(\mathbf{Z}_2 - \mathbf{Z}_m) = \mathbf{E}_1$$

Note in the above that the mutual impedance was treated as if it were an additional inductance in series with the inductance  $L_1$  having a sign determined by the dot convention and the voltage across which is determined by the current in the magnetically coupled loop.

For the secondary loop,

$$-\mathbf{Z}_2(\mathbf{I}_2 - \mathbf{I}_1) - \mathbf{I}_2\mathbf{Z}_{L_2} - \mathbf{I}_1\mathbf{Z}_m - \mathbf{I}_2\mathbf{Z}_3 = 0$$

or 
$$\mathbf{I}_2(\mathbf{Z}_2 + \mathbf{Z}_{L_2} + \mathbf{Z}_3) - \mathbf{I}_1(\mathbf{Z}_2 - \mathbf{Z}_m) = 0$$

For the network of Fig. 21.46, we find a mutual term between  $L_1$  and  $L_2$  and  $L_1$  and  $L_3$ , labeled  $M_{12}$  and  $M_{13}$ , respectively.

For the coils with the dots ( $L_1$  and  $L_3$ ), since each current through the coils leaves the dot,  $M_{13}$  is positive for the chosen direction of  $I_1$  and  $I_3$ . However, since the current  $I_1$  leaves the dot through  $L_1$ , and  $I_2$  enters the dot through coil  $L_2$ ,  $M_{12}$  is negative. Consequently, for the input circuit,

$$\mathbf{E}_1 - \mathbf{I}_1\mathbf{Z}_1 - \mathbf{I}_1\mathbf{Z}_{L_1} - \mathbf{I}_2(-\mathbf{Z}_{m_{12}}) - \mathbf{I}_3\mathbf{Z}_{m_{13}} = 0$$

or 
$$\mathbf{E}_1 - \mathbf{I}_1(\mathbf{Z}_1 + \mathbf{Z}_{L_1}) + \mathbf{I}_2\mathbf{Z}_{m_{12}} - \mathbf{I}_3\mathbf{Z}_{m_{13}} = 0$$

For loop 2,

$$\begin{aligned} -\mathbf{I}_2\mathbf{Z}_2 - \mathbf{I}_2\mathbf{Z}_{L_2} - \mathbf{I}_1(-\mathbf{Z}_{m_{12}}) &= 0 \\ -\mathbf{I}_1\mathbf{Z}_{m_{12}} + \mathbf{I}_2(\mathbf{Z}_2 + \mathbf{Z}_{L_2}) &= 0 \end{aligned}$$

and for loop 3,

$$-\mathbf{I}_3\mathbf{Z}_3 - \mathbf{I}_3\mathbf{Z}_{L_3} - \mathbf{I}_1\mathbf{Z}_{m_{13}} = 0$$

or 
$$\mathbf{I}_1\mathbf{Z}_{m_{13}} + \mathbf{I}_3(\mathbf{Z}_3 + \mathbf{Z}_{L_3}) = 0$$

In determinant form,

$$\begin{array}{rclcl} \mathbf{I}_1(\mathbf{Z}_1 + \mathbf{Z}_{L_1}) - \mathbf{I}_2\mathbf{Z}_{m_{12}} & + & \mathbf{I}_3\mathbf{Z}_{m_{13}} & = & \mathbf{E}_1 \\ -\mathbf{I}_1\mathbf{Z}_{m_{12}} & + & \mathbf{I}_2(\mathbf{Z}_2 + \mathbf{Z}_{L_2}) & + & 0 & = & 0 \\ \mathbf{I}_1\mathbf{Z}_{m_{13}} & + & 0 & + & \mathbf{I}_3(\mathbf{Z}_3 + \mathbf{Z}_{L_3}) & = & 0 \end{array}$$

## 21.14 APPLICATIONS

The transformer has appeared throughout the text in a number of described applications, from the basic dc supply to the soldering gun to the flyback transformer of a simple flash camera. Transformers were used to increase or decrease the voltage or current level, to act as an impedance matching device, or in some cases to play a dual role of transformer action and reactive element. They are so common in such a wide variety of systems that one should make an effort to be very familiar with their general characteristics. For most applications their design today is such that they can be considered 100% efficient. That is, the power applied is the power delivered to the load. In general, however, they are frequently the largest element of a design and because of the nonlinearity of the  $B$ - $H$  curve can cause some distortion of the transformed waveform. By now it should be clear that they are useful only in situations where the applied voltage is changing with time. The application of a dc voltage to the primary will result in 0 V at the secondary, but the application of a voltage that changes with time, no matter what its general appearance, will result in a voltage on the sec-

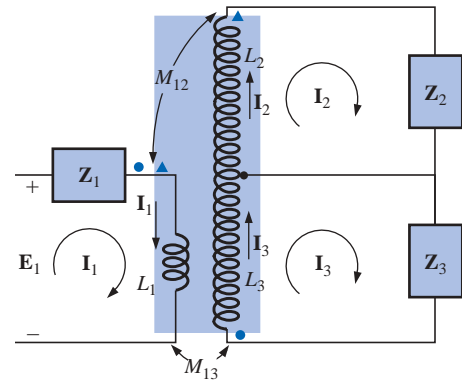


FIG. 21.46

Applying mesh analysis to a network with two magnetically coupled coils.



ondary. Always keep in mind that even though it can provide isolation between the primary and secondary circuits, a transformer can transform the load impedance to the primary circuit at a level that can significantly impact on the behavior of the network. Even the smallest impedance in the secondary can be made to appear very large in the primary when a step-down transformer is used.

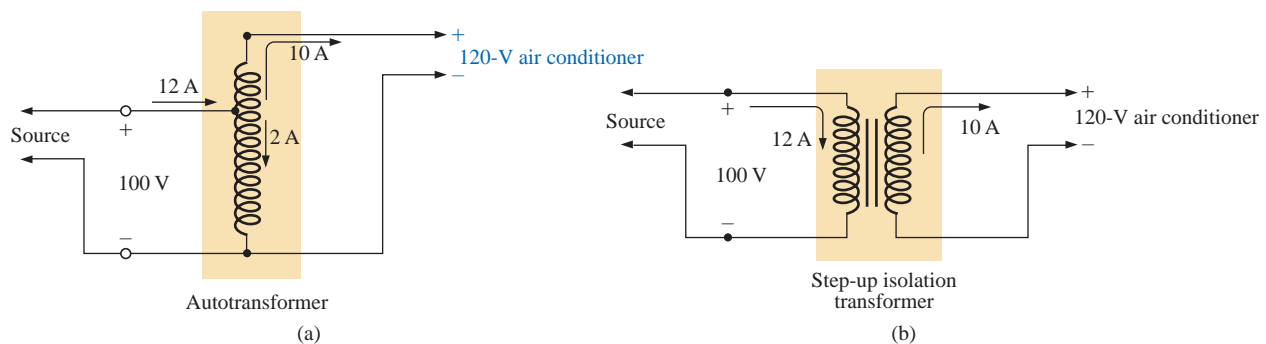
Transformers, like every other component you may use, have power ratings. The larger the power rating, the larger the resulting transformer, primarily because of the larger conductors in the windings to handle the current. The size of a transformer is also a function of the frequency involved. The lower the frequency, the larger the required transformer, as easily recognized by the size of large power transformers (also affected by the current levels as mentioned above). For the same power level the higher the frequency of transformation, the smaller the transformer can be. Because of eddy current and hysteresis losses in a transformer, the design of the core is quite important. A solid core would introduce high levels of such losses, whereas a core constructed of sheets of high-permeability steel with the proper insulation between the sheets would reduce the losses significantly.

Although very fundamental in their basic structure, transformers are recognized as one of the major building blocks of electrical and electronic systems. There isn't a publication on new components published that does not include a new design for the variety of applications developing every day.

## Low-Voltage Compensation

At times during the year, peak demands from the power company can result in a reduced voltage down the line. In midsummer, for example, the line voltage may drop from 120 V to 100 V because of the heavy load often due primarily to air conditioners. However, air conditioners do not run as well under low-voltage conditions, so the following option using an autotransformer may be the solution.

In Fig. 21.47(a), an air conditioner drawing 10 A at 120 V is connected through an autotransformer to the available supply that has dropped to 100 V. Assuming 100% efficiency, the current drawn from the line would have to be 12 A to ensure that  $P_i = P_o = 1200$  W. Using the analysis introduced in Section 21.11, we will find that the current in the primary winding is 2 A with 10 A in the secondary. The 12 A will



**FIG. 21.47**

*Maintaining a 120-V supply for an air conditioner: (a) using an autotransformer; (b) using a traditional step-up transformer.*



exist only in the line connecting the source to the primary. If the voltage level were increased using the traditional step-up transformer shown in Fig. 21.47(b), the same currents would result at the source and load. However, note that the current through the primary is now 12 A which is 6 times that in the autotransformer. The result is that the winding in the autotransformer can be much thinner due to the significantly lower current level.

Let us now examine the turns ratio required and the number of turns involved for each setup (associating one turn with each volt of the primary and secondary).

For the autotransformer:

$$\frac{N_s}{N_p} = \frac{V_s}{V_p} = \frac{10 \text{ V}}{100 \text{ V}} \Rightarrow \frac{10 \text{ t}}{100 \text{ t}}$$

For the traditional transformer:

$$\frac{N_s}{N_p} = \frac{V_s}{V_p} = \frac{120 \text{ V}}{100 \text{ V}} \Rightarrow \frac{120 \text{ t}}{100 \text{ t}}$$

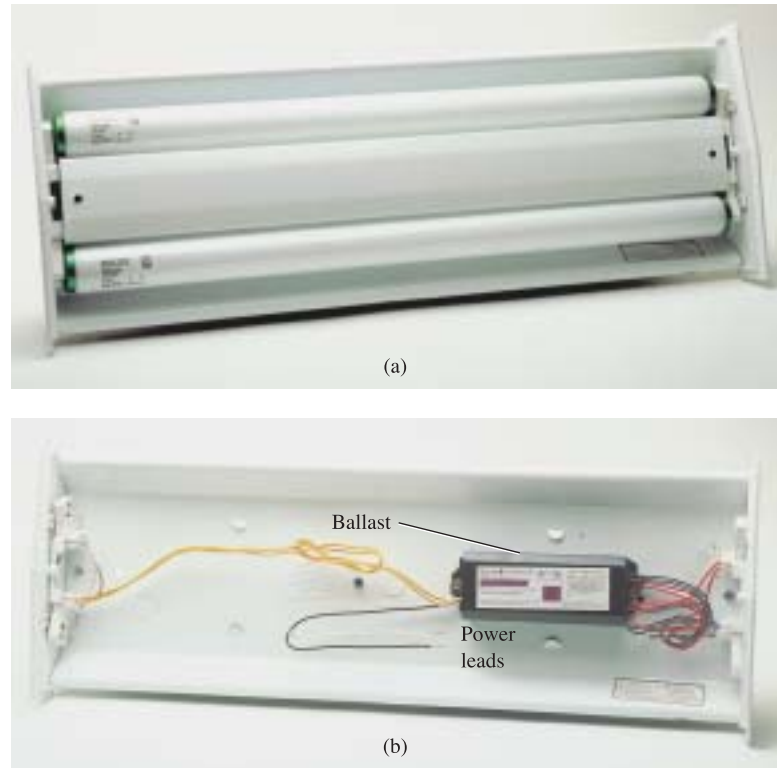
In total, therefore, the autotransformer has only 10 turns in the secondary, whereas the traditional has 120. For the autotransformer we need only 10 turns of heavy wire to handle the current of 10 A, not the full 120 required for the traditional transformer. In addition, the total number of turns for the autotransformer is 110 compared to 220 for the traditional transformer.

The net result of all the above is that even though the protection offered by the isolation feature is lost, the autotransformer can be much smaller in size and weight and, therefore, less costly.

## Ballast Transformer

Until just recently, all fluorescent lights such as appearing in Fig. 21.48(a) had a ballast transformer as shown in Fig. 21.48(b). In many cases its weight alone is almost equal to that of the fixture itself. In recent years a solid-state equivalent transformer has been developed that in time may replace most of the ballast transformers. However, for now and the near future, because of the additional cost associated with the solid-state variety, the ballast transformer will appear in most fluorescent bulbs.

The basic connections for a single-bulb fluorescent light are provided in Fig. 21.49(a). Note that the transformer is connected as an autotransformer with the full applied 120 V across the primary. When the switch is closed, the applied voltage and the voltage across the secondary will add and establish a current through the filaments of the fluorescent bulb. The starter is initially a short circuit to establish the continuous path through the two filaments. In older fluorescent bulbs the starter was a cylinder with two contacts, as shown in Fig. 21.49(b), which had to be replaced on occasion. It sat right under the fluorescent bulb near one of the bulb connections. Now, as shown by the sketch of the inside of a ballast transformer in Fig. 21.49(c), the starter is now commonly built into the ballast and can no longer be replaced. The voltage established by the autotransformer action is sufficient to heat the filaments but not light the fluorescent bulb. The fluorescent lamp is a long tube with a coating of fluorescent paint on the inside. It is filled with an inert gas and a small amount of liquid mercury. The distance between the electrodes at the ends of the lamp is too much for the applied auto-

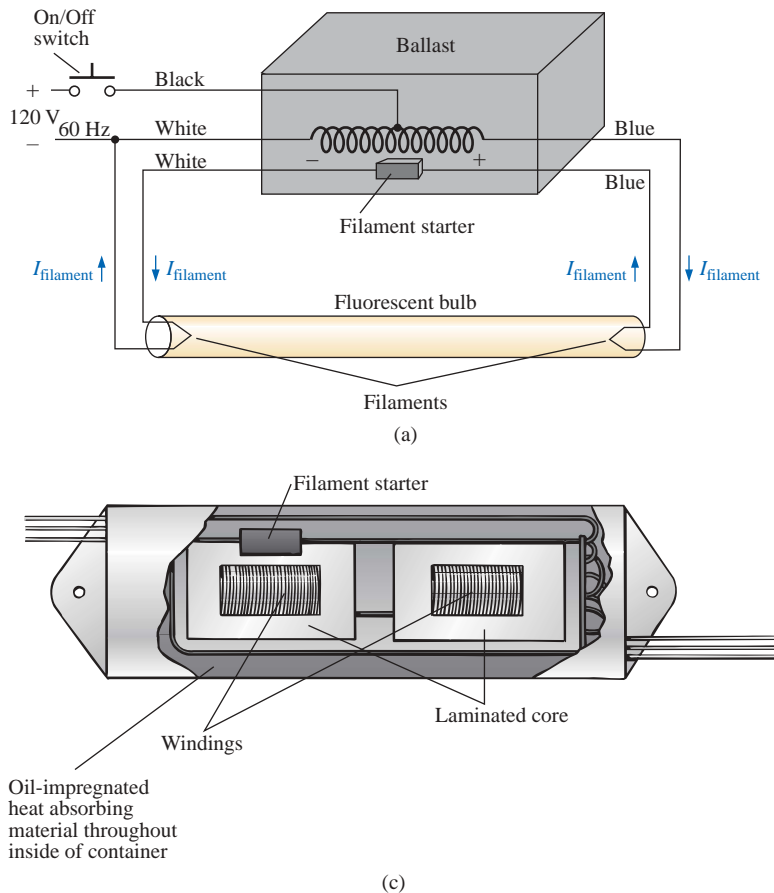


**FIG. 21.48**

*Fluorescent lamp: (a) general appearance; (b) internal view with ballast.*

transformer voltage to establish conduction. To overcome this problem, the filaments are first heated as described above to convert the mercury (a good conductor) from a liquid to a gas. Conduction can then be established by the application of a large potential across the electrodes. This potential is established when the starter (a thermal switch that opens when it reaches a particular temperature) opens and causes the inductor current to drop from its established level to zero amperes. This quick drop in current will establish a very high spike in voltage across the coils of the autotransformer as determined by  $v_L = L(di_L/dt)$ . This significant spike in voltage will also appear across the bulb and will establish current between the electrodes. Light will then be given off as the electrons hit the fluorescent surface on the inside of the tube. It is the persistence of the coating that helps hide the oscillation in conduction level due to the low-frequency (60-Hz) power that could result in a flickering light. The starter will remain open until the next time the bulb is turned on. The flow of charge between electrodes will then be maintained solely by the voltage across the autotransformer. This current is relatively low in magnitude because of the reactance of the secondary winding in the resulting series circuit. In other words, the autotransformer has shifted to one that is now providing a reactance to the secondary circuit to limit the current through the bulb. Without this limiting factor the current through the bulb would be too high, and the bulb would quickly burn out. This action of the coils of the transformer generating the required voltage and then acting as a coil to limit the current has resulted in the general terminology of *swinging choke*.

The fact that the light is not generated by an  $IR$  drop across a filament of a bulb is the reason fluorescent lights are so energy efficient. In


**FIG. 21.49**

(a) Schematic of single-bulb fluorescent lamp; (b) starter; (c) internal view of ballast transformer.

fact, in an incandescent bulb, about 75% of the applied energy is lost in heat, with only 25% going to light emission. In a fluorescent bulb more than 70% goes to light emission and 30% to heat losses. As a rule of thumb, one can assume that the lighting from a 40-W fluorescent lamp [such as the unit of Fig. 21.48(a) with its two 20-W bulbs] is equivalent to that of a 100-W incandescent bulb.

One other interesting difference between incandescent and fluorescent bulbs is the method of determining whether they are good or bad. For the incandescent light it is immediately obvious when it fails to give light at all. For the fluorescent bulb, however, assuming that the ballast is in good working order, the bulb will begin to dim as its life wears on. The electrodes will get coated and be less efficient, and the coating on the inner surface will begin to deteriorate.

*Rapid-start* fluorescent lamps are different in operation only in that the voltage generated by the transformer is sufficiently large to atomize the gas upon application and initiate conduction, thereby removing the need for a starter and eliminating the warm-up time of the filaments. In time the solid-state ballast will probably be the unit of choice because of its quick response, higher efficiency, and lighter weight, but the transition will take some time. The basic operation will remain the same, however.

Because of the fluorine gas (hence the name *fluorescent* bulb) and the mercury in fluorescent lamps, they must be discarded with care. Ask your local disposal facility where to take the bulbs. Breaking them for



insertion in a plastic bag could be a very dangerous proposition. If you happen to break a bulb and get cut in the process, be sure to go right to a medical facility since you could sustain fluorine or mercury poisoning.

## 21.15 COMPUTER ANALYSIS

### PSpice

**Transformer (Controlled Sources)** The simple transformer configuration of Fig. 21.50 will now be investigated using controlled sources to mimic the behavior of the transformer as defined by its basic voltage and current relationships.

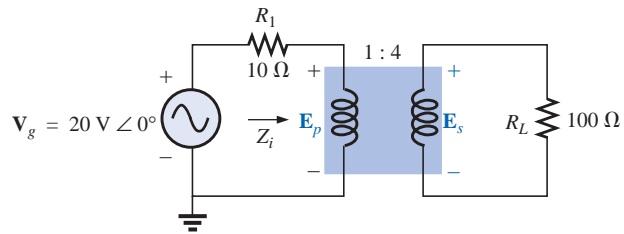


FIG. 21.50

Applying PSpice to a step-up transformer.

For comparison purposes, a theoretical solution of the network would yield the following:

$$\begin{aligned} Z_i &= a^2 Z_L \\ &= \left(\frac{1}{4}\right)^2 100 \Omega \\ &= 6.25 \Omega \end{aligned}$$

and 
$$E_p = \frac{(6.25 \Omega)(20 \text{ V})}{6.25 \Omega + 10 \Omega} = 7.692 \text{ V}$$

with 
$$E_s = \frac{1}{a} E_p = \frac{1}{(1/4)} (7.692 \text{ V}) = 4(7.692 \text{ V}) = 30.77 \text{ V}$$

and 
$$V_L = E_s = \mathbf{30.77 \text{ V}}$$

For the ideal transformer, the secondary voltage is defined by  $E_s = N_s/N_p(E_p)$  which is  $E_s = 4E_p$  for the network of Fig. 21.50. The fact that the magnitude of one voltage is controlled by another requires that we use the **Voltage-Controlled Voltage Source (VCVS)** source in the **ANALOG** library. It appears as **E** in the **Parts List** and has the format appearing in Fig. 21.51. The sensing voltage is **E1**, and the controlled voltage appears across the two terminals of the circular symbol for a voltage source. Double-clicking on the source symbol will permit setting the **GAIN** to 4 for this example. Note in Fig. 21.51 that the sensing voltage is the primary voltage of the circuit of Fig. 21.50, and the output voltage is connected directly to the load resistor **RL**. There is no real problem making the necessary connections because of the format of the **E** source.

The next step is to set up the current relationship for the transformer. Since the magnitude of one current will be controlled by the magnitude of another current in the same configuration, a **Current-Controlled**

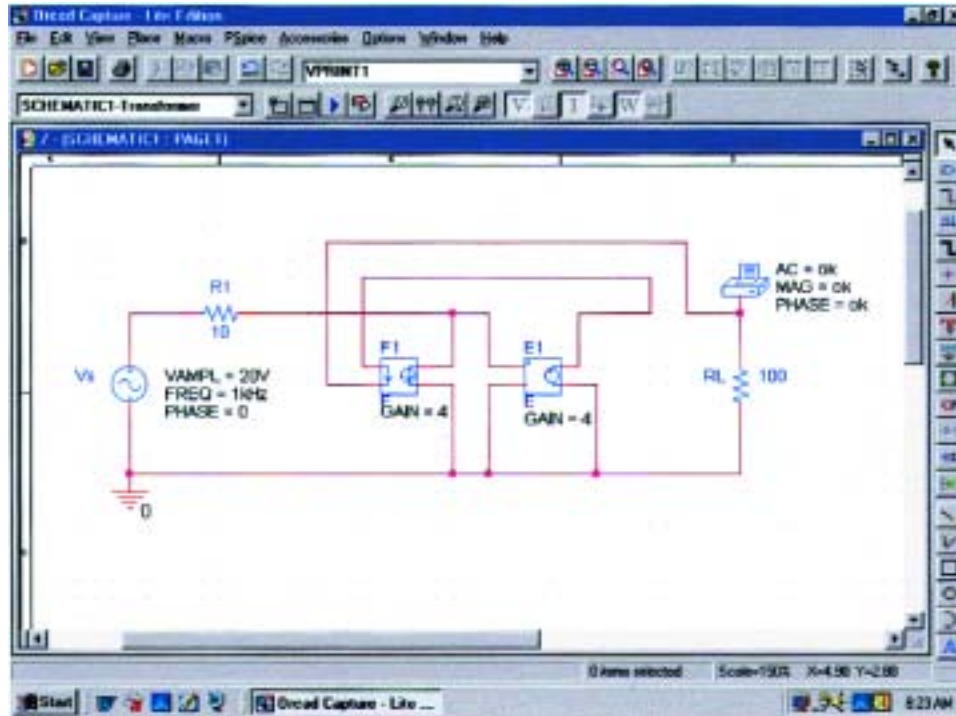


FIG. 21.51

Using PSpice to determine the magnitude and phase angle for the load voltage of the network of Fig. 21.50.

**Current Source(CCCS)** must be employed. It also appears in the **ANALOG** library under the **Part List** as **F** and has the format appearing in Fig. 21.51. Note that both currents have a direction associated with them. For the ideal transformer,  $I_p = N_s/N_p(I_s)$  which is  $I_p = 4I_s$  for the network of Fig. 21.50. The gain for the part can be set using the same procedure defined for the **E** source. Since the secondary current will be the controlling current, its level must be fed into the **F** source in the same direction as indicated in the controlled source. When making this connection, be sure to click the wire in location before crossing the wire of the primary circuit and then clicking it again after crossing the wire. If you do this properly, a connection point indicated by a small red dot will not appear. The controlled current  $I_{R_1}$  can be connected as shown because the connection **E1** is only sensing a voltage level, essentially has infinite impedance, and can be looked upon as an open circuit. In other words, the current through **R1** will be the same as through the controlled source of **F**.

A simulation was set up with **AC Sweep** and 1 kHz for the **Start** and **End Frequencies**. One data point per decade was selected, and the simulation was initiated. After the **SCHEMATIC1** screen appeared, the window was exited, and **PSpice-View Output File** was selected to result in the **AC ANALYSIS** solution of Fig. 21.52. Note that the voltage is 30.77 V, which is an exact match with the theoretical solution.

**Transformer (Library)** The same network can be analyzed by choosing one of the transformers from the **EVAL** library as shown in Fig. 21.53. The transformer labeled **K3019PL\_3C8** was chosen, and the proper attributes were placed in the **Property Editor** dialog box.



```

81:
82:  ** Profile: "SCHEMATIC1-Transformer" [ C:\PSpice\transformer-SCHEMATIC1-Trans
83:  former.sim ]
84:
85:  ****          AC ANALYSIS                      TEMPERATURE = 27.000 DEG C
86:
87:
88:  *****
89:
90:
91:
92:  FREQ          VM(N00908)  VP(N00908)
93:
94:
95:  1.000E+03    3.077E+01    0.000E+00
96:

```

FIG. 21.52

The output file for the analysis indicated in Fig. 21.51.

The only three required were **COUPLING** set at 1, **L1\_TURNS** set at 1, and **L2\_TURNS** set at 4. In the **Simulation Settings**, **AC Sweep** was chosen and **1MEGHZ** used for both the **Start and End Frequency** because it was found that it acted as an almost ideal transformer at this frequency—a little bit of run and test. When the simulation was run, the results under **PSpice-View Output File** appeared as shown in Fig. 21.54—almost an exact match with the theoretical solution of 30.77 V.

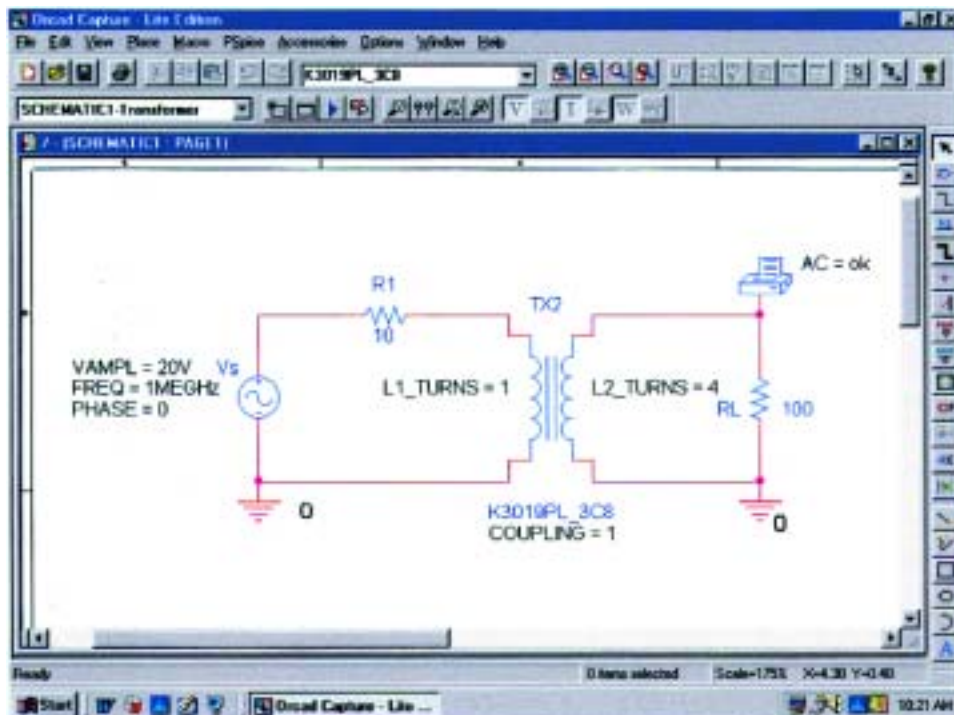


FIG. 21.53

Using a transformer provided in the **EVAL** library to analyze the network of Fig. 21.50.

```

102:
103:  ** Profile: "SCHEMATIC1-Transformer" [ C:\PSpice\transformer-SCHEMATIC1-Trans
    former.sim ]
104:
105:
106:  ****          AC ANALYSIS                      TEMPERATURE = 27.000 DEG C
107:
108:
109:  *****
110:
111:
112:
113:  FREQ          VM(N00730)
114:
115:
116:  1.000E+06    3.072E+01
117:
    
```

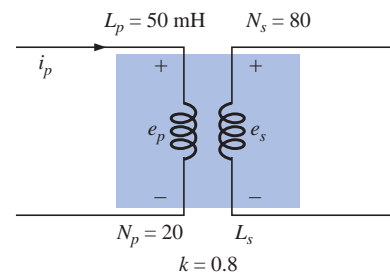
**FIG. 21.54**

The output file for the analysis indicated in Fig. 21.53.

## PROBLEMS

### SECTION 21.2 Mutual Inductance

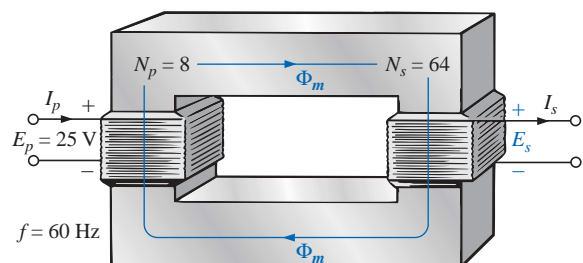
- For the air-core transformer of Fig. 21.55:
  - Find the value of  $L_s$  if the mutual inductance  $M$  is equal to 80 mH.
  - Find the induced voltages  $e_p$  and  $e_s$  if the flux linking the primary coil changes at the rate of 0.08 Wb/s.
  - Find the induced voltages  $e_p$  and  $e_s$  if the current  $i_p$  changes at the rate of 0.3 A/ms.
- Repeat Problem 1 if  $k$  is changed to 1.
  - Repeat Problem 1 if  $k$  is changed to 0.2.
  - Compare the results of parts (a) and (b).
- Repeat Problem 1 for  $k = 0.9$ ,  $N_p = 300$  turns, and  $N_s = 25$  turns.


**FIG. 21.55**

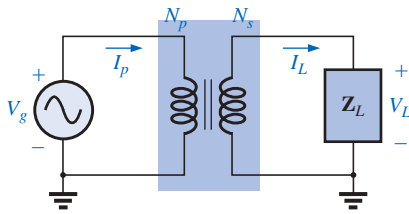
Problems 1, 2, and 3.

### SECTION 21.3 The Iron-Core Transformer

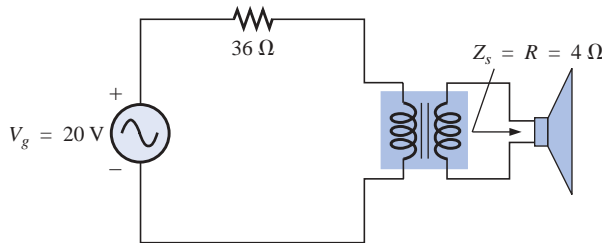
- For the iron-core transformer ( $k = 1$ ) of Fig. 21.56:
  - Find the magnitude of the induced voltage  $E_s$ .
  - Find the maximum flux  $\Phi_m$ .
- Repeat Problem 4 for  $N_p = 240$  and  $N_s = 30$ .
- Find the applied voltage of an iron-core transformer if the secondary voltage is 240 V, and  $N_p = 60$  with  $N_s = 720$ .
- If the maximum flux passing through the core of Problem 4 is 12.5 mWb, find the frequency of the input voltage.


**FIG. 21.56**

Problems 4, 5, and 7.



**FIG. 21.57**  
Problems 8 through 12.



**FIG. 21.58**  
Problem 13.

**SECTION 21.4 Reflected Impedance and Power**

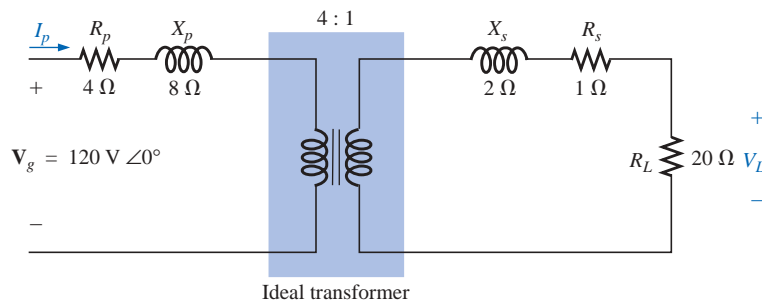
8. For the iron-core transformer of Fig. 21.57:
  - a. Find the magnitude of the current  $I_L$  and the voltage  $V_L$  if  $a = 1/5$ ,  $I_p = 2$  A, and  $Z_L = 2\text{-}\Omega$  resistor.
  - b. Find the input resistance for the data specified in part (a).
9. Find the input impedance for the iron-core transformer of Fig. 21.57 if  $a = 2$ ,  $I_p = 4$  A, and  $V_g = 1600$  V.
10. Find the voltage  $V_g$  and the current  $I_p$  if the input impedance of the iron-core transformer of Fig. 21.57 is  $4\ \Omega$ , and  $V_L = 1200$  V and  $a = 1/4$ .
11. If  $V_L = 240$  V,  $Z_L = 20\text{-}\Omega$  resistor,  $I_p = 0.05$  A, and  $N_s = 50$ , find the number of turns in the primary circuit of the iron-core transformer of Fig. 21.57.
12. a. If  $N_p = 400$ ,  $N_s = 1200$ , and  $V_g = 100$  V, find the magnitude of  $I_p$  for the iron-core transformer of Fig. 21.57 if  $Z_L = 9\ \Omega + j\ 12\ \Omega$ .  
 b. Find the magnitude of the voltage  $V_L$  and the current  $I_L$  for the conditions of part (a).

**SECTION 21.5 Impedance Matching, Isolation, and Displacement**

13. a. For the circuit of Fig. 21.58, find the transformation ratio required to deliver maximum power to the speaker.  
 b. Find the maximum power delivered to the speaker.

**SECTION 21.6 Equivalent Circuit (Iron-Core Transformer)**

14. For the transformer of Fig. 21.59, determine
  - a. the equivalent resistance  $R_e$ .
  - b. the equivalent reactance  $X_e$ .
  - c. the equivalent circuit reflected to the primary.
  - d. the primary current for  $V_g = 50\text{ V } \angle 0^\circ$ .
  - e. the load voltage  $V_L$ .
  - f. the phasor diagram of the reflected primary circuit.
  - g. the new load voltage if we assume the transformer to be ideal with a 4 : 1 turns ratio. Compare the result with that of part (e).



**FIG. 21.59**  
Problems 14 through 16, 30, and 31.



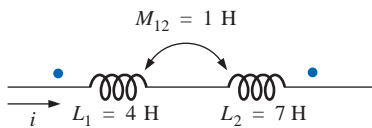
15. For the transformer of Fig. 21.59, if the resistive load is replaced by an inductive reactance of  $20 \Omega$ :
  - a. Determine the total reflected primary impedance.
  - b. Calculate the primary current.
  - c. Determine the voltage across  $R_e$  and  $X_e$ , and find the reflected load.
  - d. Draw the phasor diagram.
16. Repeat Problem 15 for a capacitive load having a reactance of  $20 \Omega$ .

**SECTION 21.7 Frequency Considerations**

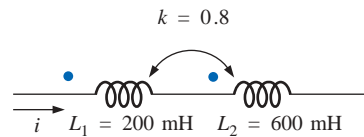
17. Discuss in your own words the frequency characteristics of the transformer. Employ the applicable equivalent circuit and frequency characteristics appearing in this chapter.

**SECTION 21.8 Series Connection of Mutually Coupled Coils**

18. Determine the total inductance of the series coils of Fig. 21.60.
19. Determine the total inductance of the series coils of Fig. 21.61.

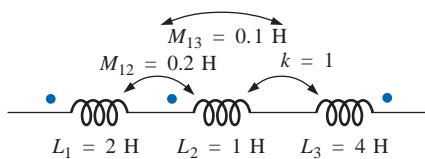


**FIG. 21.60**  
Problem 18.

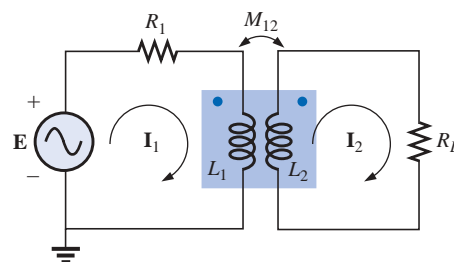


**FIG. 21.61**  
Problem 19.

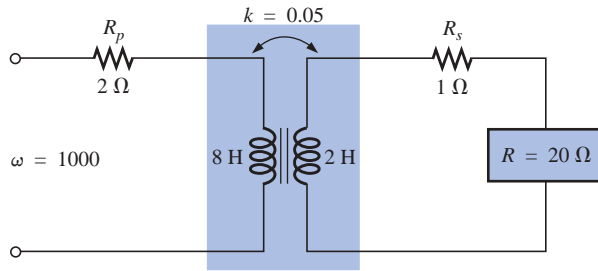
20. Determine the total inductance of the series coils of Fig. 21.62.
21. Write the mesh equations for the network of Fig. 21.63.



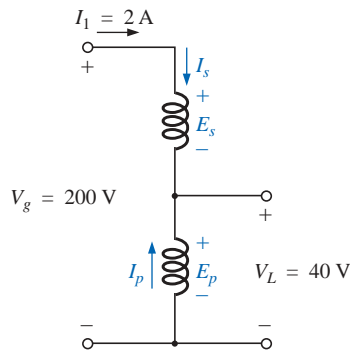
**FIG. 21.62**  
Problem 20.



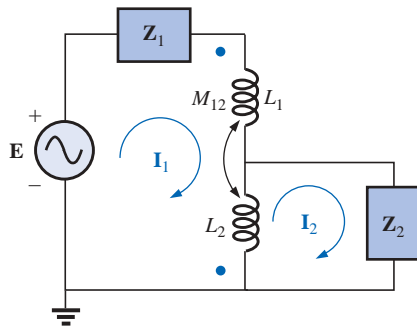
**FIG. 21.63**  
Problem 21.



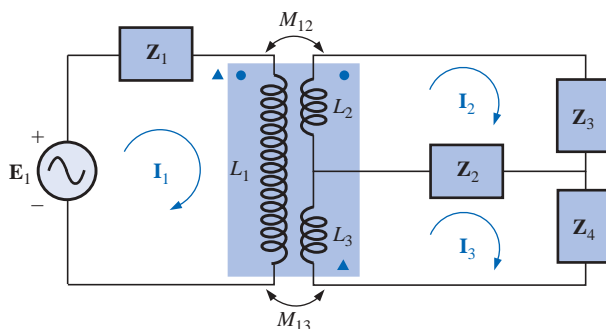
**FIG. 21.64**  
Problems 22 and 32.



**FIG. 21.65**  
Problem 24.



**FIG. 21.66**  
Problem 28.



**FIG. 21.67**  
Problem 29.

**SECTION 21.9 Air-Core Transformer**

22. Determine the input impedance to the air-core transformer of Fig. 21.64. Sketch the reflected primary network.

**SECTION 21.10 Nameplate Data**

23. An ideal transformer is rated 10 kVA, 2400/120 V, 60 Hz.
- Find the transformation ratio if the 120 V is the secondary voltage.
  - Find the current rating of the secondary if the 120 V is the secondary voltage.
  - Find the current rating of the primary if the 120 V is the secondary voltage.
  - Repeat parts (a) through (c) if the 2400 V is the secondary voltage.

**SECTION 21.11 Types of Transformers**

24. Determine the primary and secondary voltages and currents for the autotransformer of Fig. 21.65.

**SECTION 21.12 Tapped and Multiple-Load Transformers**

25. For the center-tapped transformer of Fig. 21.42 where  $N_p = 100$ ,  $N_s = 25$ ,  $Z_L = R \angle 0^\circ = 5 \Omega \angle 0^\circ$ , and  $E_p = 100 \text{ V} \angle 0^\circ$ :
- Determine the load voltage and current.
  - Find the impedance  $Z_i$ .
  - Calculate the impedance  $Z_{1/2}$ .
26. For the multiple-load transformer of Fig. 21.43 where  $N_1 = 90$ ,  $N_2 = 15$ ,  $N_3 = 45$ ,  $Z_2 = R_2 \angle 0^\circ = 8 \Omega \angle 0^\circ$ ,  $Z_3 = R_L \angle 0^\circ = 5 \Omega \angle 0^\circ$ , and  $E_i = 60 \text{ V} \angle 0^\circ$ :
- Determine the load voltages and currents.
  - Calculate  $Z_1$ .
27. For the multiple-load transformer of Fig. 21.44 where  $N_1 = 120$ ,  $N_2 = 40$ ,  $N_3 = 30$ ,  $Z_2 = R_2 \angle 0^\circ = 12 \Omega \angle 0^\circ$ ,  $Z_3 = R_3 \angle 0^\circ = 10 \Omega \angle 0^\circ$ , and  $E_1 = 120 \text{ V} \angle 60^\circ$ :
- Determine the load voltages and currents.
  - Calculate  $Z_1$ .

**SECTION 21.13 Networks with Magnetically Coupled Coils**

28. Write the mesh equations for the network of Fig. 21.66.
29. Write the mesh equations for the network of Fig. 21.67.

**SECTION 21.15 Computer Analysis**

**PSpice or Electronics Workbench**

- \*30. Generate the schematic for the network of Fig. 21.59, and find the voltage  $V_L$ .
- \*31. Develop a technique using PSpice or EWB to find the input impedance at the source for the network of Fig. 21.59.
- \*32. Using a transformer from the library, find the load voltage for the network of Fig. 21.64 for an applied voltage of  $40 \text{ V} \angle 0^\circ$ .

**Programming Language (C++, QBASIC, Pascal, etc.)**

33. Write a program to provide a general solution to the problem of impedance matching as defined by Example



21.5. That is, given the speaker impedance and the internal resistance of the source, determine the required turns ratio and the power delivered to the speaker. In addition, calculate the load and source current and the primary and secondary voltages. The source voltage will have to be provided with the other parameters of the network.

34. Given the equivalent model of an iron-core transformer appearing in Fig. 21.20, write a program to calculate the magnitude of the voltage  $V_g$ .

35. Given the parameters of Example 21.7, write a program to calculate the input impedance in polar form.

## GLOSSARY

**Autotransformer** A transformer with one winding common to both the primary and the secondary circuits. A loss in isolation is balanced by the increase in its kilovolt-ampere rating.

**Coefficient of coupling ( $k$ )** A measure of the magnetic coupling of two coils that ranges from a minimum of 0 to a maximum of 1.

**Dot convention** A technique for labeling the effect of the mutual inductance on a net inductance of a network or system.

**Leakage flux** The flux linking the coil that does not pass through the ferromagnetic path of the magnetic circuit.

**Loosely coupled** A term applied to two coils that have a low coefficient of coupling.

**Multiple-load transformers** Transformers having more than a single load connected to the secondary winding or windings.

**Mutual inductance** The inductance that exists between magnetically coupled coils of the same or different dimensions.

**Nameplate data** Information such as the kilovolt-ampere rating, voltage transformation ratio, and frequency of application that is of primary importance in choosing the proper transformer for a particular application.

**Primary** The coil or winding to which the source of electrical energy is normally applied.

**Reflected impedance** The impedance appearing at the primary of a transformer due to a load connected to the secondary. Its magnitude is controlled directly by the transformation ratio.

**Secondary** The coil or winding to which the load is normally applied.

**Step-down transformer** A transformer whose secondary voltage is less than its primary voltage. The transformation ratio  $a$  is greater than 1.

**Step-up transformer** A transformer whose secondary voltage is greater than its primary voltage. The magnitude of the transformation ratio  $a$  is less than 1.

**Tapped transformer** A transformer having an additional connection between the terminals of the primary or secondary windings.

**Transformation ratio ( $a$ )** The ratio of primary to secondary turns of a transformer.

