

# Decibels, Filters, and Bode Plots

## 23.1 LOGARITHMS

The use of logarithms in industry is so extensive that a clear understanding of their purpose and use is an absolute necessity. At first exposure, logarithms often appear vague and mysterious due to the mathematical operations required to find the logarithm and antilogarithm using the longhand table approach that is typically taught in mathematics courses. However, almost all of today's scientific calculators have the common and natural log functions, eliminating the complexity of applying logarithms and allowing us to concentrate on the positive characteristics of the function.

### Basic Relationships

Let us first examine the relationship between the variables of the logarithmic function. The mathematical expression

$$N = (b)^x$$

states that the number  $N$  is equal to the base  $b$  taken to the power  $x$ . A few examples:

$$\begin{aligned} 100 &= (10)^2 \\ 27 &= (3)^3 \\ 54.6 &= (e)^4 \quad \text{where } e = 2.7183 \end{aligned}$$

If the question were to find the power  $x$  to satisfy the equation

$$1200 = (10)^x$$

the value of  $x$  could be determined using logarithms in the following manner:

$$x = \log_{10} 1200 = \mathbf{3.079}$$

revealing that

$$10^{3.079} = 1200$$

Note that the logarithm was taken to the base 10—the number to be taken to the power of  $x$ . There is no limitation to the numerical value of the base except that tables and calculators are designed to handle either a base of 10 (common logarithm,  $\boxed{\text{LOG}}$ ) or base  $e = 2.7183$  (natural logarithm,  $\boxed{\text{LN}}$ ). In review, therefore,

$$\text{If } N = (b)^x, \text{ then } x = \log_b N. \quad (23.1)$$

The base to be employed is a function of the area of application. If a conversion from one base to the other is required, the following equation can be applied:

$$\log_e x = 2.3 \log_{10} x \quad (23.2)$$

The content of this chapter is such that we will concentrate solely on the common logarithm. However, a number of the conclusions are also applicable to natural logarithms.

## Some Areas of Application

The following is a short list of the most common applications of the logarithmic function:

1. This chapter will demonstrate that the use of logarithms permits plotting the response of a system for a range of values that may otherwise be impossible or unwieldy with a linear scale.
2. Levels of power, voltage, and the like, can be compared without dealing with very large or very small numbers that often cloud the true impact of the difference in magnitudes.
3. A number of systems respond to outside stimuli in a nonlinear logarithmic manner. The result is a mathematical model that permits a direct calculation of the response of the system to a particular input signal.
4. The response of a cascaded or compound system can be rapidly determined using logarithms if the gain of each stage is known on a logarithmic basis. This characteristic will be demonstrated in an example to follow.

## Graphs

Graph paper is available in the **semilog** and **log-log** varieties. Semilog paper has only one log scale, with the other a linear scale. Both scales of log-log paper are log scales. A section of semilog paper appears in Fig. 23.1. Note the linear (even-spaced-interval) vertical scaling and the repeating intervals of the log scale at multiples of 10.

The spacing of the log scale is determined by taking the common log (base 10) of the number. The scaling starts with 1, since  $\log_{10} 1 = 0$ . The distance between 1 and 2 is determined by  $\log_{10} 2 = 0.3010$ , or approximately 30% of the full distance of a log interval, as shown on the graph. The distance between 1 and 3 is determined by  $\log_{10} 3 = 0.4771$ , or about 48% of the full width. For future reference, keep in mind that almost 50% of the width of one log interval is represented by a 3 rather than by the 5 of a linear scale. In addition, note that the number 5 is about 70% of the full width, and 8 is about 90%. Remembering the percentage of full width of the

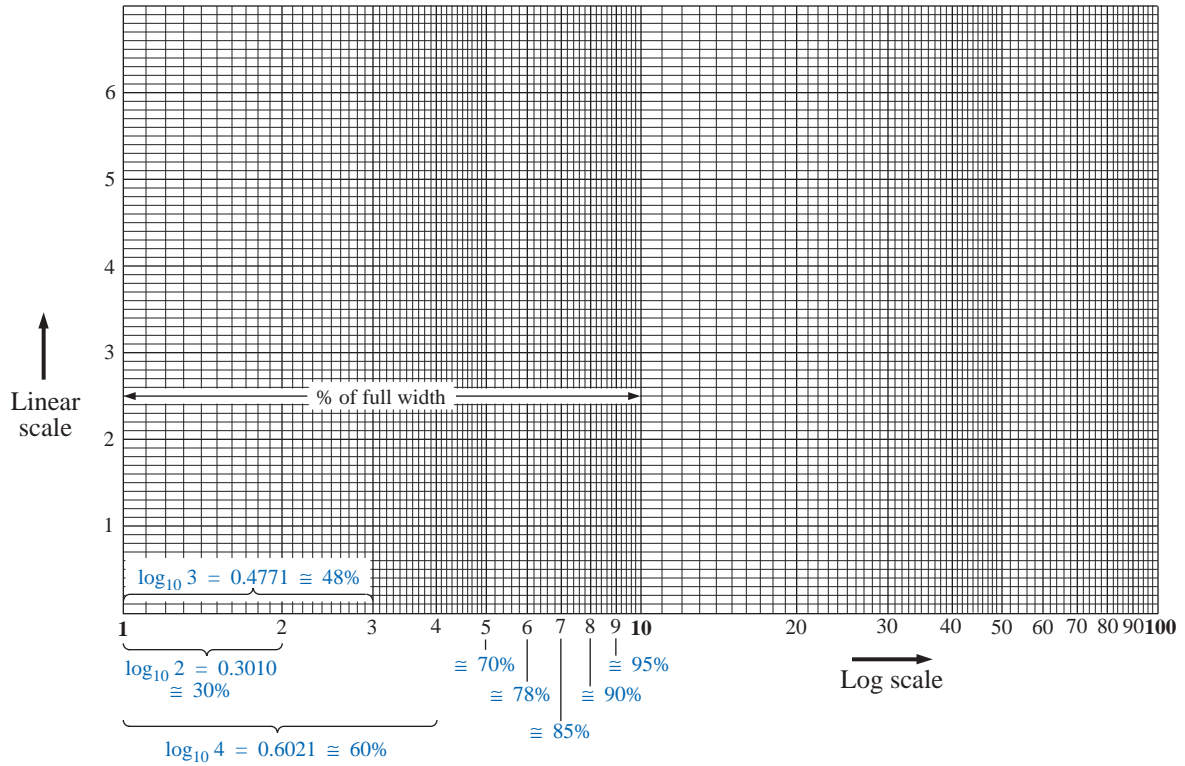

**FIG. 23.1**  
*Semilog graph paper.*

lines 2, 3, 5, and 8 will be particularly useful when the various lines of a log plot are left unnumbered.

Since

$$\begin{aligned} \log_{10} 1 &= 0 \\ \log_{10} 10 &= 1 \\ \log_{10} 100 &= 2 \\ \log_{10} 1000 &= 3 \\ &\vdots \end{aligned}$$

the spacing between 1 and 10, 10 and 100, 100 and 1000, and so on, will be the same as shown in Figs. 23.1 and 23.2.

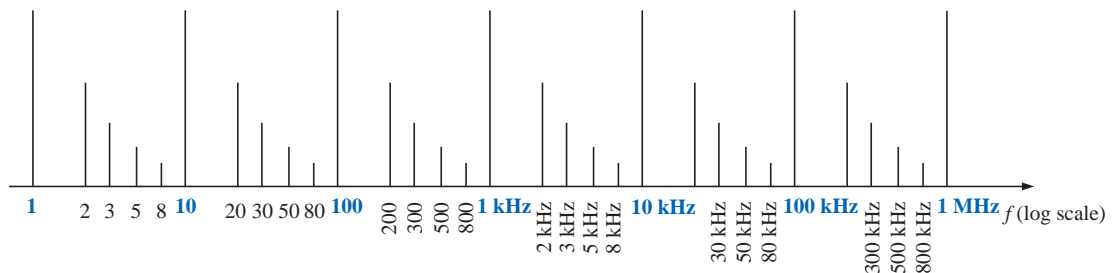

**FIG. 23.2**  
*Frequency log scale.*

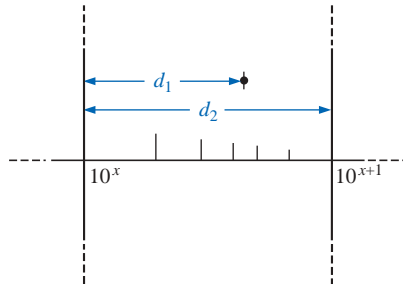

FIG. 23.3

Finding a value on a log plot.

Note in Figs. 23.1 and 23.2 that the log scale becomes compressed at the high end of each interval. With increasing frequency levels assigned to each interval, a single graph can provide a frequency plot extending from 1 Hz to 1 MHz, as shown in Fig. 23.2, with particular reference to the 30%, 50%, 70%, and 90% levels of each interval.

On many log plots, the tick marks for most of the intermediate levels are left off because of space constraints. The following equation can be used to determine the logarithmic level at a particular point between known levels using a ruler or simply estimating the distances. The parameters are defined by Fig. 23.3.

$$\text{Value} = 10^x \times 10^{d_1/d_2} \quad (23.3)$$

The derivation of Eq. (23.3) is simply an extension of the details regarding distance appearing on Fig. 23.1.

### EXAMPLE 23.1

Determine the value of the point appearing on the logarithmic plot of Fig. 23.4 using the measurements made by a ruler (linear).

**Solution:**

$$\frac{d_1}{d_2} = \frac{7/16''}{3/4''} = \frac{0.438''}{0.750''} = 0.584$$

Using a calculator:

$$10^{d_1/d_2} = 10^{0.584} = 3.837$$

Applying Eq. (23.3):

$$\begin{aligned} \text{Value} &= 10^x \times 10^{d_1/d_2} = 10^2 \times 3.837 \\ &= \mathbf{383.7} \end{aligned}$$

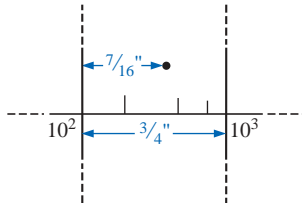

FIG. 23.4

Example 23.1.

## 23.2 PROPERTIES OF LOGARITHMS

There are a few characteristics of logarithms that should be emphasized:

1. *The common or natural logarithm of the number 1 is 0.*

$$\log_{10} 1 = 0 \quad (23.4)$$

just as  $10^x = 1$  requires that  $x = 0$ .

2. *The log of any number less than 1 is a negative number.*

$$\log_{10} \frac{1}{2} = \log_{10} 0.5 = -0.3$$

$$\log_{10} \frac{1}{10} = \log_{10} 0.1 = -1$$

3. *The log of the product of two numbers is the sum of the logs of the numbers.*

$$\log_{10} ab = \log_{10} a + \log_{10} b \quad (23.5)$$

4. *The log of the quotient of two numbers is the log of the numerator minus the log of the denominator.*

$$\log_{10} \frac{a}{b} = \log_{10} a - \log_{10} b \quad (23.6)$$

**5. The log of a number taken to a power is equal to the product of the power and the log of the number.**

$$\log_{10} a^n = n \log_{10} a \quad (23.7)$$

## Calculator Functions

On most calculators the log of a number is found by simply entering the number and pressing the **LOG** or **LN** key.

For example,

$$\log_{10} 80 = \boxed{8} \boxed{0} \boxed{\text{LOG}}$$

with a display of **1.903**.

For the reverse process, where  $N$ , or the antilogarithm, is desired, the function  $10^x$  is employed. On most calculators  $10^x$  appears as a second function above the **LOG** key. For the case of

$$0.6 = \log_{10} N$$

the following keys are employed:

$$\boxed{\cdot} \boxed{6} \boxed{2\text{NDF}} \boxed{10^x}$$

with a display of **3.981**. Checking:  $\log_{10} 3.981 = 0.6$ .

---

**EXAMPLE 23.2** Evaluate each of the following logarithmic expressions:

- $\log_{10} 0.004$
- $\log_{10} 250,000$
- $\log_{10}(0.08)(240)$
- $\log_{10} \frac{1 \times 10^4}{1 \times 10^{-4}}$
- $\log_{10}(10)^4$

**Solutions:**

- 2.398**
  - +5.398**
  - $\log_{10}(0.08)(240) = \log_{10} 0.08 + \log_{10} 240 = -1.097 + 2.380$   
**= 1.283**
  - $\log_{10} \frac{1 \times 10^4}{1 \times 10^{-4}} = \log_{10} 1 \times 10^4 - \log_{10} 1 \times 10^{-4} = 4 - (-4)$   
**= 8**
  - $\log_{10} 10^4 = 4 \log_{10} 10 = 4(1) = \mathbf{4}$
- 

## 23.3 DECIBELS

### Power Gain

Two levels of power can be compared using a unit of measure called the *bel*, which is defined by the following equation:

$$B = \log_{10} \frac{P_2}{P_1} \quad (\text{bels}) \quad (23.8)$$

However, to provide a unit of measure of *less* magnitude, a **decibel** is defined, where

$$1 \text{ bel} = 10 \text{ decibels (dB)} \quad (23.9)$$

The result is the following important equation, which compares power levels  $P_2$  and  $P_1$  in decibels:

$$\text{dB} = 10 \log_{10} \frac{P_2}{P_1} \quad (\text{decibels, dB}) \quad (23.10)$$

If the power levels are equal ( $P_2 = P_1$ ), there is no change in power level, and  $\text{dB} = 0$ . If there is an increase in power level ( $P_2 > P_1$ ), the resulting decibel level is positive. If there is a decrease in power level ( $P_2 < P_1$ ), the resulting decibel level will be negative.

For the special case of  $P_2 = 2P_1$ , the gain in decibels is

$$\text{dB} = 10 \log_{10} \frac{P_2}{P_1} = 10 \log_{10} 2 = \mathbf{3 \text{ dB}}$$

Therefore, for a speaker system, a 3-dB increase in output would require that the power level be doubled. In the audio industry, it is a generally accepted rule that an increase in sound level is accomplished with 3-dB increments in the output level. In other words, a 1-dB increase is barely detectable, and a 2-dB increase just discernible. A 3-dB increase normally results in a readily detectable increase in sound level. An additional increase in the sound level is normally accomplished by simply increasing the output level another 3 dB. If an 8-W system were in use, a 3-dB increase would require a 16-W output, whereas an additional increase of 3 dB (a total of 6 dB) would require a 32-W system, as demonstrated by the calculations below:

$$\text{dB} = 10 \log_{10} \frac{P_2}{P_1} = 10 \log_{10} \frac{16}{8} = 10 \log_{10} 2 = \mathbf{3 \text{ dB}}$$

$$\text{dB} = 10 \log_{10} \frac{P_2}{P_1} = 10 \log_{10} \frac{32}{8} = 10 \log_{10} 4 = \mathbf{6 \text{ dB}}$$

For  $P_2 = 10P_1$ ,

$$\text{dB} = 10 \log_{10} \frac{P_2}{P_1} = 10 \log_{10} 10 = 10(1) = \mathbf{10 \text{ dB}}$$

resulting in the unique situation where the power gain has the same magnitude as the decibel level.

For some applications, a reference level is established to permit a comparison of decibel levels from one situation to another. For communication systems a commonly applied reference level is

$$P_{\text{ref}} = 1 \text{ mW} \quad (\text{across a } 600\text{-}\Omega \text{ load})$$

Equation (23.10) is then typically written as

$$\boxed{\text{dB}_m = 10 \log_{10} \frac{P}{1 \text{ mW}} \Big|_{600 \Omega}} \quad (23.11)$$

Note the subscript  $m$  to denote that the decibel level is determined with a reference level of 1 mW.

In particular, for  $P = 40 \text{ mW}$ ,

$$\text{dB}_m = 10 \log_{10} \frac{40 \text{ mW}}{1 \text{ mW}} = 10 \log_{10} 40 = 10(1.6) = \mathbf{16 \text{ dB}_m}$$

whereas for  $P = 4 \text{ W}$ ,

$$\text{dB}_m = 10 \log_{10} \frac{4000 \text{ mW}}{1 \text{ mW}} = 10 \log_{10} 4000 = 10(3.6) = \mathbf{36 \text{ dB}_m}$$

Even though the power level has increased by a factor of  $4000 \text{ mW}/40 \text{ mW} = 100$ , the  $\text{dB}_m$  increase is limited to  $20 \text{ dB}_m$ . In time, the significance of  $\text{dB}_m$  levels of  $16 \text{ dB}_m$  and  $36 \text{ dB}_m$  will generate an immediate appreciation regarding the power levels involved. An increase of  $20 \text{ dB}_m$  will also be associated with a significant gain in power levels.

## Voltage Gain

Decibels are also used to provide a comparison between voltage levels. Substituting the basic power equations  $P_2 = V_2^2/R_2$  and  $P_1 = V_1^2/R_1$  into Eq. (23.10) will result in

$$\begin{aligned} \text{dB} &= 10 \log_{10} \frac{P_2}{P_1} = 10 \log_{10} \frac{V_2^2/R_2}{V_1^2/R_1} \\ &= 10 \log_{10} \frac{V_2^2/V_1^2}{R_2/R_1} = 10 \log_{10} \left( \frac{V_2}{V_1} \right)^2 - 10 \log_{10} \left( \frac{R_2}{R_1} \right) \end{aligned}$$

$$\text{and} \quad \text{dB} = 20 \log_{10} \frac{V_2}{V_1} - 10 \log_{10} \frac{R_2}{R_1}$$

For the situation where  $R_2 = R_1$ , a condition normally assumed when comparing voltage levels on a decibel basis, the second term of the preceding equation will drop out ( $\log_{10} 1 = 0$ ), and

$$\boxed{\text{dB}_v = 20 \log_{10} \frac{V_2}{V_1}} \quad (\text{dB}) \quad (23.12)$$

Note the subscript  $v$  to define the decibel level obtained.

**EXAMPLE 23.3** Find the voltage gain in dB of a system where the applied signal is 2 mV and the output voltage is 1.2 V.

**Solution:**

$$\text{dB}_v = 20 \log_{10} \frac{V_o}{V_i} = 20 \log_{10} \frac{1.2 \text{ V}}{2 \text{ mV}} = 20 \log_{10} 600 = \mathbf{55.56 \text{ dB}}$$

for a voltage gain  $A_v = V_o/V_i$  of 600.

**EXAMPLE 23.4** If a system has a voltage gain of 36 dB, find the applied voltage if the output voltage is 6.8 V.

**Solution:**

$$\text{dB}_v = 20 \log_{10} \frac{V_o}{V_i}$$

$$36 = 20 \log_{10} \frac{V_o}{V_i}$$

$$1.8 = \log_{10} \frac{V_o}{V_i}$$

From the antilogarithm:

$$\frac{V_o}{V_i} = 63.096$$

and 
$$V_i = \frac{V_o}{63.096} = \frac{6.8 \text{ V}}{63.096} = \mathbf{107.77 \text{ mV}}$$

**TABLE 23.1**

| $V_o/V_i$ | $\text{dB} = 20 \log_{10}(V_o/V_i)$ |
|-----------|-------------------------------------|
| 1         | 0 dB                                |
| 2         | 6 dB                                |
| 10        | 20 dB                               |
| 20        | 26 dB                               |
| 100       | 40 dB                               |
| 1,000     | 60 dB                               |
| 100,000   | 100 dB                              |

Table 23.1 compares the magnitude of specific gains to the resulting decibel level. In particular, note that when voltage levels are compared, a doubling of the level results in a change of 6 dB rather than 3 dB as obtained for power levels.

In addition, note that an increase in gain from 1 to 100,000 results in a change in decibels that can easily be plotted on a single graph. Also note that doubling the gain (from 1 to 2 and 10 to 20) results in a 6-dB increase in the decibel level, while a change of 10 to 1 (from 1 to 10, 10 to 100, and so on) always results in a 20-dB decrease in the decibel level.

## The Human Auditory Response

One of the most frequent applications of the decibel scale is in the communication and entertainment industries. The human ear does not respond in a linear fashion to changes in source power level; that is, a doubling of the audio power level from 1/2 W to 1 W does not result in a doubling of the loudness level for the human ear. In addition, a change from 5 W to 10 W will be received by the ear as the same change in sound intensity as experienced from 1/2 W to 1 W. In other words, the ratio between levels is the same in each case ( $1 \text{ W}/0.5 \text{ W} = 10 \text{ W}/5 \text{ W} = 2$ ), resulting in the same decibel or logarithmic change defined by Eq. (23.7). The ear, therefore, responds in a logarithmic fashion to changes in audio power levels.

To establish a basis for comparison between audio levels, a reference level of 0.0002 **microbar** ( $\mu\text{bar}$ ) was chosen, where 1  $\mu\text{bar}$  is equal to the sound pressure of 1 dyne per square centimeter, or about 1 millionth of the normal atmospheric pressure at sea level. The 0.0002- $\mu\text{bar}$  level is the threshold level of hearing. Using this reference level, the sound pressure level in decibels is defined by the following equation:

$$\text{dB}_s = 20 \log_{10} \frac{P}{0.0002 \mu\text{bar}} \quad (23.13)$$

where  $P$  is the sound pressure in microbars.

The decibel levels of Fig. 23.5 are defined by Eq. (23.13). Meters designed to measure audio levels are calibrated to the levels defined by Eq. (23.13) and shown in Fig. 23.5.

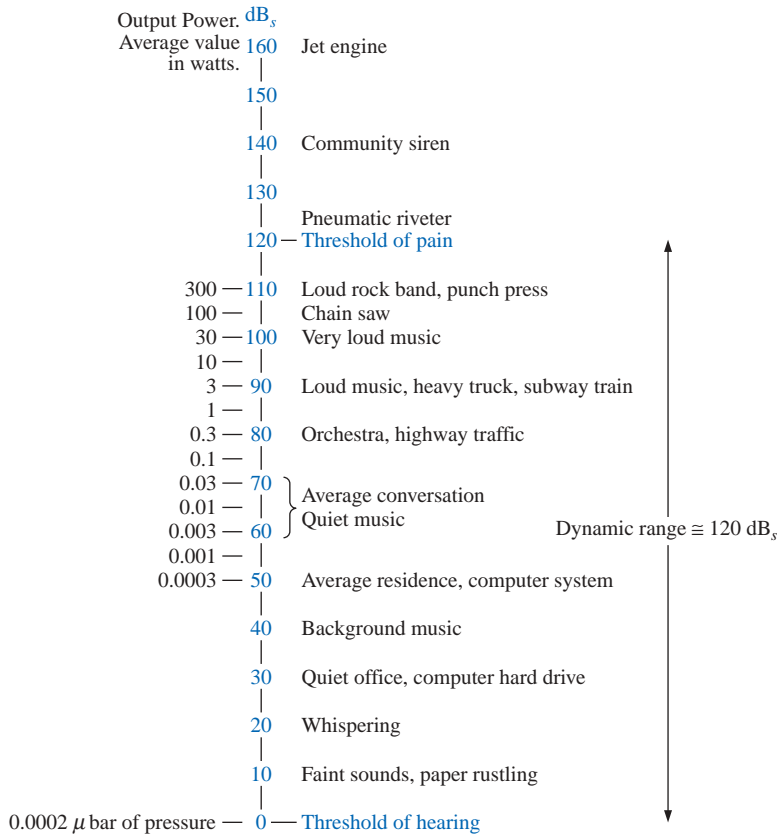

FIG. 23.5

*Typical sound levels and their decibel levels.*

A common question regarding audio levels is how much the power level of an acoustical source must be increased to double the sound level received by the human ear. The question is not as simple as it first seems due to considerations such as the frequency content of the sound, the acoustical conditions of the surrounding area, the physical characteristics of the surrounding medium, and—of course—the unique characteristics of the human ear. However, a general conclusion can be formulated that has practical value if we note the power levels of an acoustical source appearing to the left of Fig. 23.5. Each power level is associated with a particular decibel level, and a change of 10 dB in the scale corresponds with an increase or a decrease in power by a factor of 10. For instance, a change from 90 dB to 100 dB is associated with a change in wattage from 3 W to 30 W. Through experimentation it has been found that on an average basis the loudness level will double for every 10-dB change in audio level—a conclusion somewhat verified by the examples to the right of Fig. 23.5. Using the fact that a 10-dB change corresponds with a tenfold increase in power level supports the following conclusion (on an approximate basis): Through experimentation it has been found that on an average basis, the loudness level will double for every 10-dB change in audio level.

***To double the sound level received by the human ear, the power rating of the acoustical source (in watts) must be increased by a factor of 10.***

In other words, doubling the sound level available from a 1-W acoustical source would require moving up to a 10-W source.

### Instrumentation

A number of modern VOMs and DMMs have a dB scale designed to provide an indication of power ratios referenced to a standard level of 1 mW at 600  $\Omega$ . Since the reading is accurate only if the load has a characteristic impedance of 600  $\Omega$ , the 1-mW, 600 reference level is normally printed somewhere on the face of the meter, as shown in Fig. 23.6. The dB scale is usually calibrated to the lowest ac scale of the meter. In other

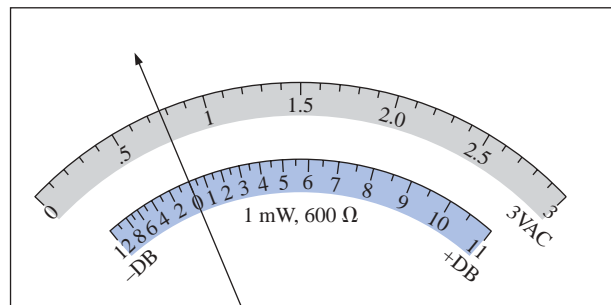

FIG. 23.6

Defining the relationship between a dB scale referenced to 1 mW, 600  $\Omega$  and a 3-V-rms voltage scale.

words, when making the dB measurement, choose the lowest ac voltage scale, but read the dB scale. If a higher voltage scale is chosen, a correction factor must be employed that is sometimes printed on the face of the meter but always available in the meter manual. If the impedance is other than 600  $\Omega$  or not purely resistive, other correction factors must be used that are normally included in the meter manual. Using the basic power equation  $P = V^2/R$  will reveal that 1 mW across a 600- $\Omega$  load is the same as applying 0.775 V rms across a 600- $\Omega$  load; that is,  $V = \sqrt{PR} = \sqrt{(1 \text{ mW})(600 \Omega)} = 0.775 \text{ V}$ . The result is that an analog display will have 0 dB [defining the reference point of 1 mW,  $\text{dB} = 10 \log_{10} P_2/P_1 = 10 \log_{10} (1 \text{ mW}/1 \text{ mW}(\text{ref})) = 0 \text{ dB}$ ] and 0.775 V rms on the same pointer projection, as shown in Fig. 23.6. A voltage of 2.5 V across a 600- $\Omega$  load would result in a dB level of  $\text{dB} = 20 \log_{10} V_2/V_1 = 20 \log_{10} 2.5 \text{ V}/0.775 = 10.17 \text{ dB}$ , resulting in 2.5 V and 10.17 dB appearing along the same pointer projection. A voltage of less than 0.775 V, such as 0.5 V, will result in a dB level of  $\text{dB} = 20 \log_{10} V_2/V_1 = 20 \log_{10} 0.5 \text{ V}/0.775 \text{ V} = -3.8 \text{ dB}$ , as is also shown on the scale of Fig. 23.6. Although a reading of 10 dB will reveal that the power level is 10 times the reference, don't assume that a reading of 5 dB means that the output level is 5 mW. The 10:1 ratio is a special one in logarithmic circles. For the 5-dB level, the power level must be found using the antilogarithm (3.126), which reveals that the power level associated with 5 dB is about 3.1 times the reference or 3.1 mW. A conversion table is usually provided in the manual for such conversions.

### 23.4 FILTERS

Any combination of passive ( $R$ ,  $L$ , and  $C$ ) and/or active (transistors or operational amplifiers) elements designed to select or reject a band of

frequencies is called a **filter**. In communication systems, filters are employed to pass those frequencies containing the desired information and to reject the remaining frequencies. In stereo systems, filters can be used to isolate particular bands of frequencies for increased or decreased emphasis by the output acoustical system (amplifier, speaker, etc.). Filters are employed to filter out any unwanted frequencies, commonly called *noise*, due to the nonlinear characteristics of some electronic devices or signals picked up from the surrounding medium. In general, there are two classifications of filters:

1. **Passive filters** are those filters composed of series or parallel combinations of  $R$ ,  $L$ , and  $C$  elements.
2. **Active filters** are filters that employ active devices such as transistors and operational amplifiers in combination with  $R$ ,  $L$ , and  $C$  elements.

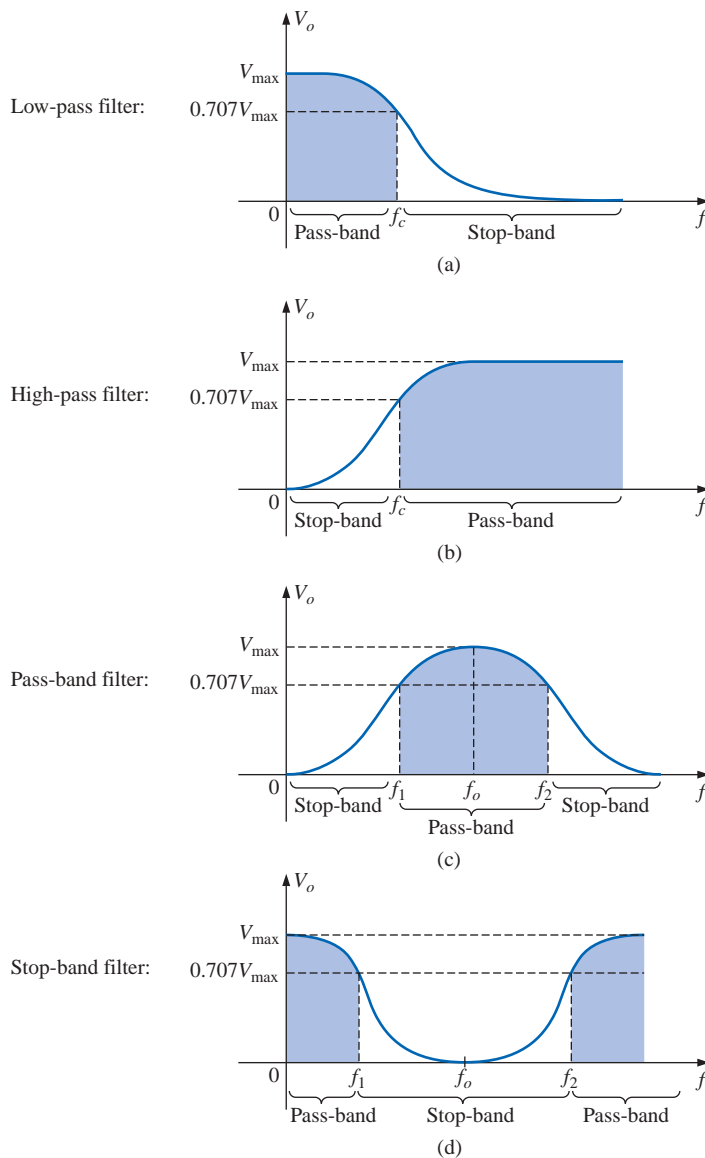

**FIG. 23.7**

Defining the four broad categories of filters.

Since this text is limited to passive devices, the analysis of this chapter will be limited to passive filters. In addition, only the most fundamental forms will be examined in the next few sections. The subject of filters is a very broad one that continues to receive extensive research support from industry and the government as new communication systems are developed to meet the demands of increased volume and speed. There are courses and texts devoted solely to the analysis and design of filter systems that can become quite complex and sophisticated. In general, however, all filters belong to the four broad categories of **low-pass**, **high-pass**, **pass-band**, and **stop-band**, as depicted in Fig. 23.7. For each form there are critical frequencies that define the regions of pass-bands and stop-bands (often called *reject* bands). Any frequency in the pass-band will pass through to the next stage with at least 70.7% of the maximum output voltage. Recall the use of the 0.707 level to define the bandwidth of a series or parallel resonant circuit (both with the general shape of the pass-band filter).

For some stop-band filters, the stop-band is defined by conditions other than the 0.707 level. In fact, for many stop-band filters, the condition that  $V_o = 1/1000V_{\max}$  (corresponding with  $-60$  dB in the discussion to follow) is used to define the stop-band region, with the pass-band continuing to be defined by the 0.707-V level. The resulting frequencies between the two regions are then called the *transition frequencies* and establish the *transition region*.

At least one example of each filter of Fig. 23.7 will be discussed in some detail in the sections to follow. Take particular note of the relative simplicity of some of the designs.

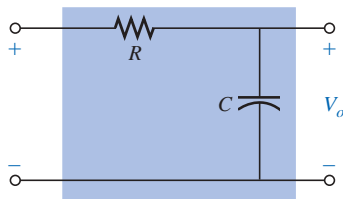

FIG. 23.8  
Low-pass filter.

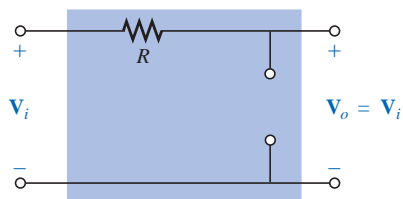

FIG. 23.9  
R-C low-pass filter at low frequencies.

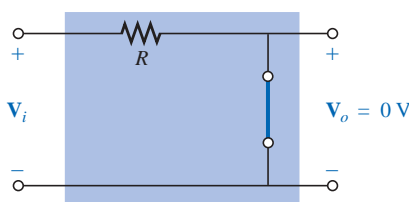

FIG. 23.10  
R-C low-pass filter at high frequencies.

## 23.5 R-C LOW-PASS FILTER

The R-C filter, incredibly simple in design, can be used as a low-pass or a high-pass filter. If the output is taken off the capacitor, as shown in Fig. 23.8, it will respond as a low-pass filter. If the positions of the resistor and capacitor are interchanged and the output is taken off the resistor, the response will be that of a high-pass filter.

A glance at Fig. 23.7(a) reveals that the circuit should behave in a manner that will result in a high-level output for low frequencies and a declining level for frequencies above the critical value. Let us first examine the network at the frequency extremes of  $f = 0$  Hz and very high frequencies to test the response of the circuit.

At  $f = 0$  Hz,

$$X_C = \frac{1}{2\pi fC} = \infty \Omega$$

and the open-circuit equivalent can be substituted for the capacitor, as shown in Fig. 23.9, resulting in  $V_o = V_i$ .

At very high frequencies, the reactance is

$$X_C = \frac{1}{2\pi fC} \cong 0 \Omega$$

and the short-circuit equivalent can be substituted for the capacitor, as shown in Fig. 23.10, resulting in  $V_o = 0$  V.

A plot of the magnitude of  $V_o$  versus frequency will result in the curve of Fig. 23.11. Our next goal is now clearly defined: Find the frequency at which the transition takes place from a pass-band to a stop-band.

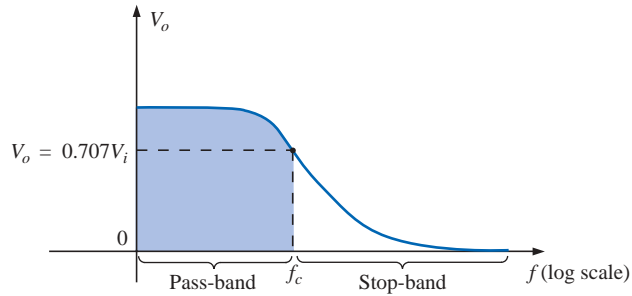

FIG. 23.11

$V_o$  versus frequency for a low-pass R-C filter.

For filters, a normalized plot is employed more often than the plot of  $V_o$  versus frequency of Fig. 23.11.

**Normalization is a process whereby a quantity such as voltage, current, or impedance is divided by a quantity of the same unit of measure to establish a dimensionless level of a specific value or range.**

A normalized plot in the filter domain can be obtained by dividing the plotted quantity such as  $V_o$  of Fig. 23.11 with the applied voltage  $V_i$  for the frequency range of interest. Since the maximum value of  $V_o$  for the low-pass filter of Fig. 23.8 is  $V_i$ , each level of  $V_o$  in Fig. 23.11 is divided by the level of  $V_i$ . The result is the plot of  $A_v = V_o/V_i$  of Fig. 23.12. Note that the maximum value is 1 and the cutoff frequency is defined at the 0.707 level.

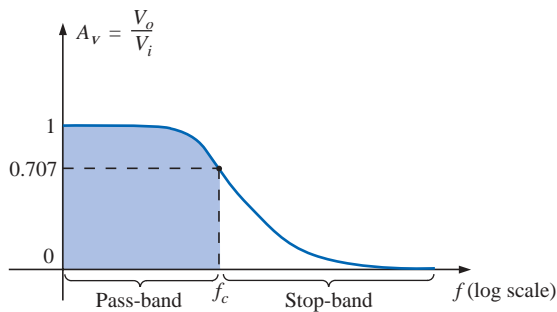

FIG. 23.12

Normalized plot of Fig. 23.11.

At any intermediate frequency, the output voltage  $V_o$  of Fig. 23.8 can be determined using the voltage divider rule:

$$\mathbf{V}_o = \frac{X_C \angle -90^\circ \mathbf{V}_i}{R - jX_C}$$

or

$$\mathbf{A}_v = \frac{\mathbf{V}_o}{\mathbf{V}_i} = \frac{X_C \angle -90^\circ}{R - jX_C} = \frac{X_C \angle -90^\circ}{\sqrt{R^2 + X_C^2} \angle -\tan^{-1}(X_C/R)}$$

and

$$\mathbf{A}_v = \frac{\mathbf{V}_o}{\mathbf{V}_i} = \frac{X_C}{\sqrt{R^2 + X_C^2}} \angle -90^\circ + \tan^{-1}\left(\frac{X_C}{R}\right)$$

The magnitude of the ratio  $V_o/V_i$  is therefore determined by

$$A_v = \frac{V_o}{V_i} = \frac{X_C}{\sqrt{R^2 + X_C^2}} = \frac{1}{\sqrt{\left(\frac{R}{X_C}\right)^2 + 1}} \quad (23.14)$$

and the phase angle is determined by

$$\theta = -90^\circ + \tan^{-1} \frac{X_C}{R} = -\tan^{-1} \frac{R}{X_C} \quad (23.15)$$

For the special frequency at which  $X_C = R$ , the magnitude becomes

$$A_v = \frac{V_o}{V_i} = \frac{1}{\sqrt{\left(\frac{R}{X_C}\right)^2 + 1}} = \frac{1}{\sqrt{1 + 1}} = \frac{1}{\sqrt{2}} = 0.707$$

which defines the critical or cutoff frequency of Fig. 23.12.

The frequency at which  $X_C = R$  is determined by

$$\frac{1}{2\pi f_c C} = R$$

and

$$f_c = \frac{1}{2\pi RC} \quad (23.16)$$

The impact of Eq. (23.16) extends beyond its relative simplicity. For any low-pass filter, the application of any frequency less than  $f_c$  will result in an output voltage  $V_o$  that is at least 70.7% of the maximum. For any frequency above  $f_c$ , the output is less than 70.7% of the applied signal.

Solving for  $\mathbf{V}_o$  and substituting  $\mathbf{V}_i = V_i \angle 0^\circ$  gives

$$\mathbf{V}_o = \left[ \frac{X_C}{\sqrt{R^2 + X_C^2}} \angle \theta \right] \mathbf{V}_i = \left[ \frac{X_C}{\sqrt{R^2 + X_C^2}} \angle \theta \right] V_i \angle 0^\circ$$

and

$$\mathbf{V}_o = \frac{X_C V_i}{\sqrt{R^2 + X_C^2}} \angle \theta$$

The angle  $\theta$  is, therefore, the angle by which  $\mathbf{V}_o$  leads  $\mathbf{V}_i$ . Since  $\theta = -\tan^{-1} R/X_C$  is always negative (except at  $f = 0$  Hz), it is clear that  $\mathbf{V}_o$  will always lag  $\mathbf{V}_i$ , leading to the label *lagging network* for the network of Fig. 23.8.

At high frequencies,  $X_C$  is very small and  $R/X_C$  is quite large, resulting in  $\theta = -\tan^{-1} R/X_C$  approaching  $-90^\circ$ .

At low frequencies,  $X_C$  is quite large and  $R/X_C$  is very small, resulting in  $\theta$  approaching  $0^\circ$ .

At  $X_C = R$ , or  $f = f_c$ ,  $-\tan^{-1} R/X_C = -\tan^{-1} 1 = -45^\circ$ .

A plot of  $\theta$  versus frequency results in the phase plot of Fig. 23.13.

The plot is of  $\mathbf{V}_o$  leading  $\mathbf{V}_i$ , but since the phase angle is always negative, the phase plot of Fig. 23.14 ( $\mathbf{V}_o$  lagging  $\mathbf{V}_i$ ) is more appropriate. Note that a change in sign requires that the vertical axis be changed to the angle by which  $\mathbf{V}_o$  lags  $\mathbf{V}_i$ . In particular, note that the phase angle between  $\mathbf{V}_o$  and  $\mathbf{V}_i$  is less than  $45^\circ$  in the pass-band and approaches  $0^\circ$

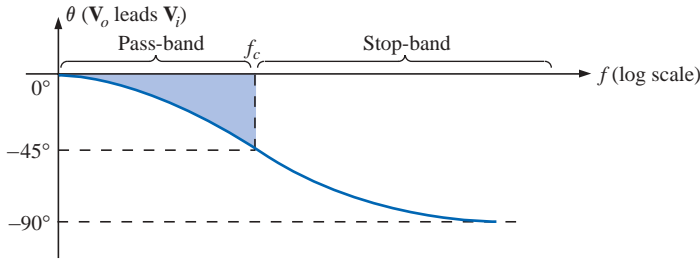

**FIG. 23.13**  
Angle by which  $V_o$  leads  $V_i$ .

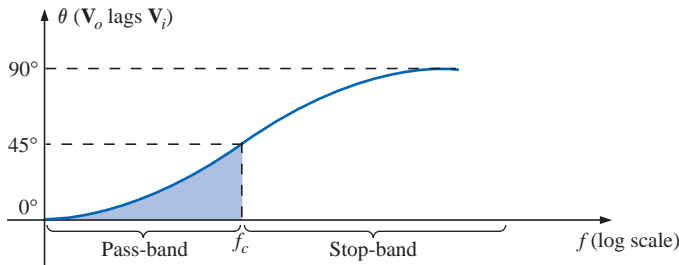

**FIG. 23.14**  
Angle by which  $V_o$  lags  $V_i$ .

at lower frequencies.

In summary, for the low-pass R-C filter of Fig. 23.8:

|                           |                                |                  |
|---------------------------|--------------------------------|------------------|
| $f_c = \frac{1}{2\pi RC}$ |                                |                  |
| For                       | $f < f_c$ ,                    | $V_o > 0.707V_i$ |
| whereas for               | $f > f_c$ ,                    | $V_o < 0.707V_i$ |
| At $f_c$ ,                | $V_o$ lags $V_i$ by $45^\circ$ |                  |

The low-pass filter response of Fig. 23.7(a) can also be obtained using the R-L combination of Fig. 23.15 with

$$f_c = \frac{R}{2\pi L} \tag{23.17}$$

In general, however, the R-C combination is more popular due to the smaller size of capacitive elements and the nonlinearities associated with inductive elements. The details of the analysis of the low-pass R-L will be left as an exercise for the reader.

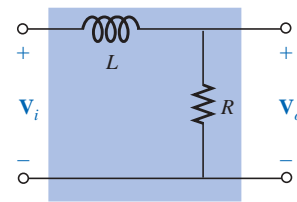

**FIG. 23.15**  
Low-pass R-L filter.

**EXAMPLE 23.5**

- Sketch the output voltage  $V_o$  versus frequency for the low-pass R-C filter of Fig. 23.16.
- Determine the voltage  $V_o$  at  $f = 100$  kHz and 1 MHz, and compare the results to the results obtained from the curve of part (a).
- Sketch the normalized gain  $A_v = V_o/V_i$ .

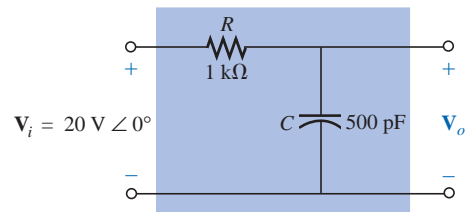
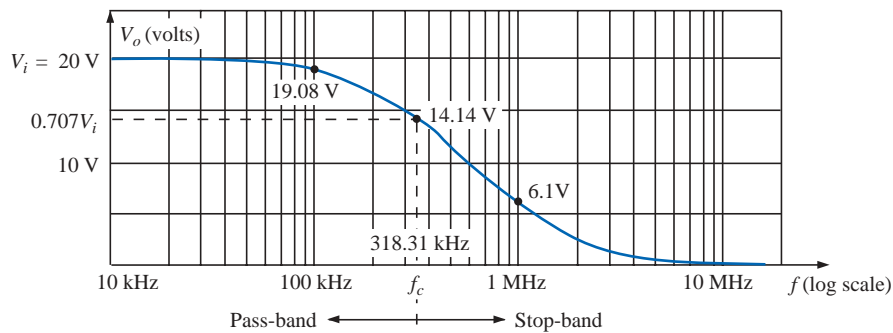

**FIG. 23.16**  
Example 23.5.

**Solutions:**

a. Eq. (23.16):

$$f_c = \frac{1}{2\pi RC} = \frac{1}{2\pi(1 \text{ k}\Omega)(500 \text{ pF})} = \mathbf{318.31 \text{ kHz}}$$

At  $f_c$ ,  $V_o = 0.707(20 \text{ V}) = 14.14 \text{ V}$ . See Fig. 23.17.**FIG. 23.17**

Frequency response for the low-pass R-C network of Fig. 23.16.

b. Eq. (23.14):

$$V_o = \frac{V_i}{\sqrt{\left(\frac{R}{X_C}\right)^2 + 1}}$$

At  $f = 100 \text{ kHz}$ :

$$X_C = \frac{1}{2\pi fC} = \frac{1}{2\pi(100 \text{ kHz})(500 \text{ pF})} = 3.18 \text{ k}\Omega$$

$$\text{and } V_o = \frac{20 \text{ V}}{\sqrt{\left(\frac{1 \text{ k}\Omega}{3.18 \text{ k}\Omega}\right)^2 + 1}} = \mathbf{19.08 \text{ V}}$$

At  $f = 1 \text{ MHz}$ :

$$X_C = \frac{1}{2\pi fC} = \frac{1}{2\pi(1 \text{ MHz})(500 \text{ pF})} = 0.32 \text{ k}\Omega$$

$$\text{and } V_o = \frac{20 \text{ V}}{\sqrt{\left(\frac{1 \text{ k}\Omega}{0.32 \text{ k}\Omega}\right)^2 + 1}} = \mathbf{6.1 \text{ V}}$$

Both levels are verified by Fig. 23.17.

c. Dividing every level of Fig. 23.17 by  $V_i = 20 \text{ V}$  will result in the normalized plot of Fig. 23.18.

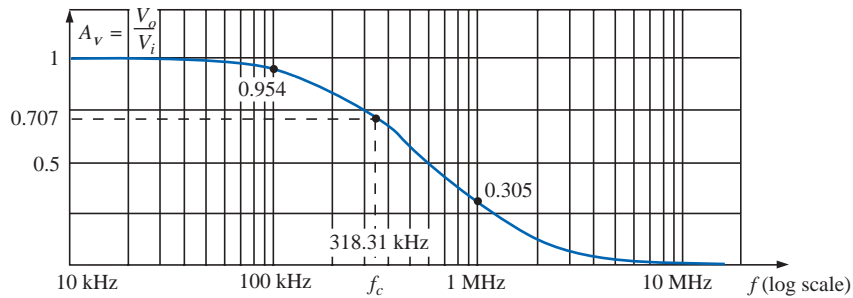
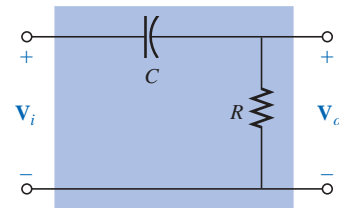

**FIG. 23.18**  
Normalized plot of Fig. 23.17.

### 23.6 R-C HIGH-PASS FILTER

As noted early in Section 23.5, a high-pass R-C filter can be constructed by simply reversing the positions of the capacitor and resistor, as shown in Fig. 23.19.

At very high frequencies the reactance of the capacitor is very small, and the short-circuit equivalent can be substituted, as shown in Fig. 23.20. The result is that  $V_o = V_i$ .



**FIG. 23.19**  
High-pass filter.

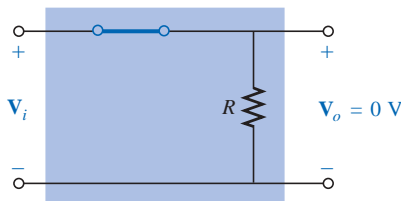

**FIG. 23.20**  
R-C high-pass filter at very high frequencies.

At  $f = 0$  Hz, the reactance of the capacitor is quite high, and the open-circuit equivalent can be substituted, as shown in Fig. 23.21. In this case,  $V_o = 0$  V.

A plot of the magnitude versus frequency is provided in Fig. 23.22, with the normalized plot in Fig. 23.23.

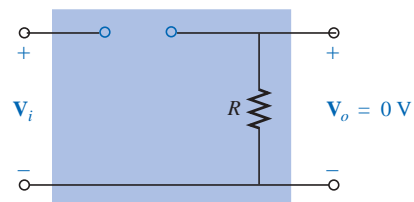

**FIG. 23.21**  
R-C high-pass filter at  $f = 0$  Hz.

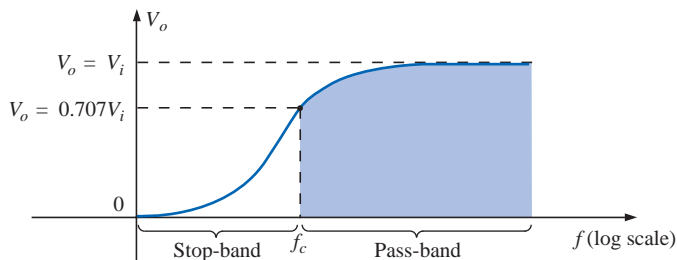

**FIG. 23.22**  
 $V_o$  versus frequency for a high-pass R-C filter.

At any intermediate frequency, the output voltage can be determined using the voltage divider rule:

$$V_o = \frac{R \angle 0^\circ V_i}{R - jX_C}$$

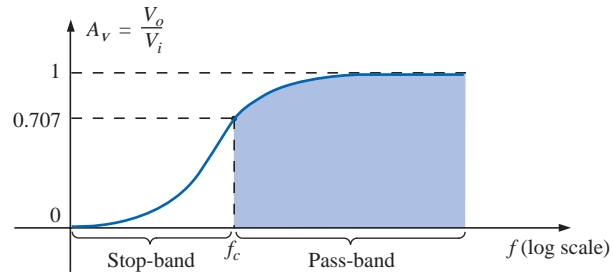

FIG. 23.23

Normalized plot of Fig. 23.22.

or

$$\frac{\mathbf{V}_o}{\mathbf{V}_i} = \frac{R \angle 0^\circ}{R - jX_C} = \frac{R \angle 0^\circ}{\sqrt{R^2 + X_C^2} \angle -\tan^{-1}(X_C/R)}$$

and

$$\frac{\mathbf{V}_o}{\mathbf{V}_i} = \frac{R}{\sqrt{R^2 + X_C^2}} \angle \tan^{-1}(X_C/R)$$

The magnitude of the ratio  $\mathbf{V}_o/\mathbf{V}_i$  is therefore determined by

$$A_v = \frac{V_o}{V_i} = \frac{R}{\sqrt{R^2 + X_C^2}} = \frac{1}{\sqrt{1 + \left(\frac{X_C}{R}\right)^2}} \quad (23.18)$$

and the phase angle  $\theta$  by

$$\theta = \tan^{-1} \frac{X_C}{R} \quad (23.19)$$

For the frequency at which  $X_C = R$ , the magnitude becomes

$$\frac{V_o}{V_i} = \frac{1}{\sqrt{1 + \left(\frac{X_C}{R}\right)^2}} = \frac{1}{\sqrt{1 + 1}} = \frac{1}{\sqrt{2}} = 0.707$$

as shown in Fig. 23.23.

The frequency at which  $X_C = R$  is determined by

$$X_C = \frac{1}{2\pi f_c C} = R$$

and

$$f_c = \frac{1}{2\pi RC} \quad (23.20)$$

For the high-pass  $R$ - $C$  filter, the application of any frequency greater than  $f_c$  will result in an output voltage  $V_o$  that is at least 70.7% of the magnitude of the input signal. For any frequency below  $f_c$ , the output is less than 70.7% of the applied signal.

For the phase angle, high frequencies result in small values of  $X_C$ , and the ratio  $X_C/R$  will approach zero with  $\tan^{-1}(X_C/R)$  approaching  $0^\circ$ , as shown in Fig. 23.24. At low frequencies, the ratio  $X_C/R$  becomes

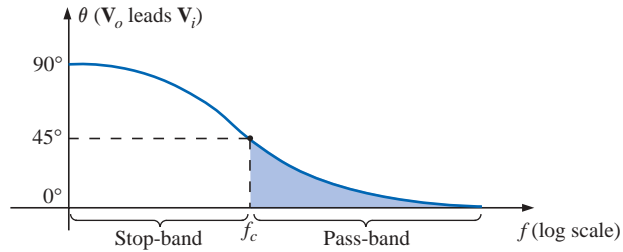

FIG. 23.24

Phase-angle response for the high-pass R-C filter.

quite large, and  $\tan^{-1}(X_C/R)$  approaches  $90^\circ$ . For the case  $X_C = R$ ,  $\tan^{-1}(X_C/R) = \tan^{-1} 1 = 45^\circ$ . Assigning a phase angle of  $0^\circ$  to  $\mathbf{V}_i$  such that  $\mathbf{V}_i = V_i \angle 0^\circ$ , the phase angle associated with  $\mathbf{V}_o$  is  $\theta$ , resulting in  $\mathbf{V}_o = V_o \angle \theta$  and revealing that  $\theta$  is the angle by which  $\mathbf{V}_o$  leads  $\mathbf{V}_i$ . Since the angle  $\theta$  is the angle by which  $\mathbf{V}_o$  leads  $\mathbf{V}_i$  throughout the frequency range of Fig. 23.24, the high-pass R-C filter is referred to as a *leading network*.

In summary, for the high-pass R-C filter:

|             |   |                  |
|-------------|---|------------------|
|             | $f_c = \frac{1}{2\pi RC}$                         |                  |
| For         | $f < f_c$   | $V_o < 0.707V_i$ |
| whereas for | $f > f_c$   | $V_o > 0.707V_i$ |
| At $f_c$ ,  | $\mathbf{V}_o$ leads $\mathbf{V}_i$ by $45^\circ$ |                  |

The high-pass filter response of Fig. 23.23 can also be obtained using the same elements of Fig. 23.15 but interchanging their positions, as shown in Fig. 23.25.

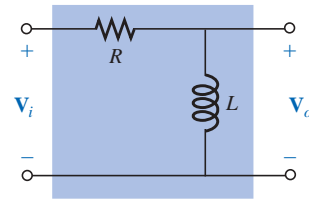

FIG. 23.25

High-pass R-L filter.

**EXAMPLE 23.6** Given  $R = 20 \text{ k}\Omega$  and  $C = 1200 \text{ pF}$ :

- Sketch the normalized plot if the filter is used as both a high-pass and a low-pass filter.
- Sketch the phase plot for both filters of part (a).
- Determine the magnitude and phase of  $\mathbf{A}_v = \mathbf{V}_o/\mathbf{V}_i$  at  $f = \frac{1}{2}f_c$  for the high-pass filter.

**Solutions:**

$$\begin{aligned} \text{a. } f_c &= \frac{1}{2\pi RC} = \frac{1}{(2\pi)(20 \text{ k}\Omega)(1200 \text{ pF})} \\ &= \mathbf{6631.46 \text{ Hz}} \end{aligned}$$

The normalized plots appear in Fig. 23.26.

- The phase plots appear in Fig. 23.27.

$$\text{c. } f = \frac{1}{2}f_c = \frac{1}{2} (6631.46 \text{ Hz}) = 3315.73 \text{ Hz}$$

$$\begin{aligned} X_C &= \frac{1}{2\pi fC} = \frac{1}{(2\pi)(3315.73 \text{ Hz})(1200 \text{ pF})} \\ &\cong 40 \text{ k}\Omega \end{aligned}$$

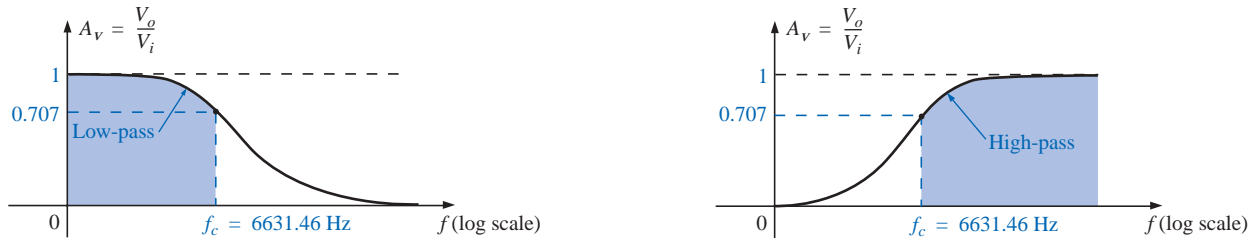

FIG. 23.26

Normalized plots for a low-pass and a high-pass filter using the same elements.

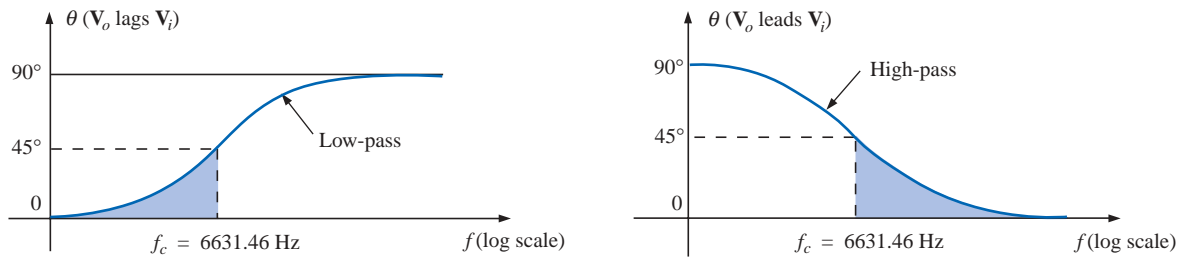

FIG. 23.27

Phase plots for a low-pass and a high-pass filter using the same elements.

$$A_v = \frac{V_o}{V_i} = \frac{1}{\sqrt{1 + \left(\frac{X_C}{R}\right)^2}} = \frac{1}{\sqrt{1 + \left(\frac{40 \text{ k}\Omega}{20 \text{ k}\Omega}\right)^2}} = \frac{1}{\sqrt{1 + (2)^2}}$$

$$= \frac{1}{\sqrt{5}} = 0.4472$$

$$\theta = \tan^{-1} \frac{X_C}{R} = \tan^{-1} \frac{40 \text{ k}\Omega}{20 \text{ k}\Omega} = \tan^{-1} 2 = 63.43^\circ$$

and  $A_v = \frac{V_o}{V_i} = 0.4472 \angle 63.43^\circ$

### 23.7 PASS-BAND FILTERS

A number of methods are used to establish the pass-band characteristic of Fig. 23.7(c). One method employs both a low-pass and a high-pass filter in cascade, as shown in Fig. 23.28.

The components are chosen to establish a cutoff frequency for the high-pass filter that is lower than the critical frequency of the low-pass filter, as shown in Fig. 23.29. A frequency  $f_1$  may pass through the low-

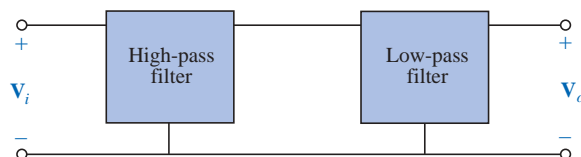
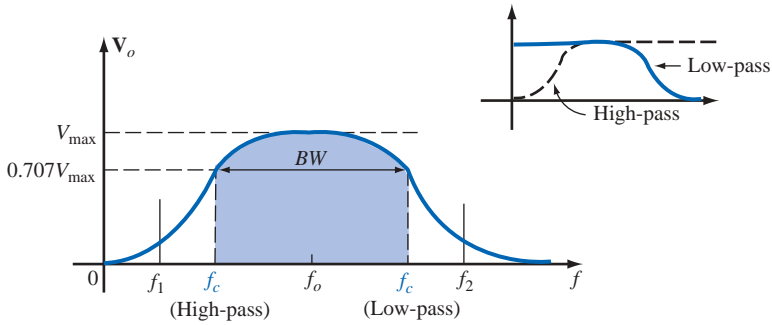

FIG. 23.28

Pass-band filter.



**FIG. 23.29**  
Pass-band characteristics.

pass filter but have little effect on  $V_o$  due to the reject characteristics of the high-pass filter. A frequency  $f_2$  may pass through the high-pass filter unmolested but be prohibited from reaching the high-pass filter by the low-pass characteristics. A frequency  $f_o$  near the center of the pass-band will pass through both filters with very little degeneration.

The network of Example 23.7 will generate the characteristics of Fig. 23.29. However, for a circuit such as the one shown in Fig. 23.30, there is a loading between stages at each frequency that will affect the level of  $V_o$ . Through proper design, the level of  $V_o$  may be very near the level of  $V_i$  in the pass-band, but it will never equal it exactly. In addition, as the critical frequencies of each filter get closer and closer together to increase the quality factor of the response curve, the peak values within the pass-band will continue to drop. For cases where  $V_{o_{\max}} \neq V_{i_{\max}}$  the bandwidth is defined at 0.707 of the resulting  $V_{o_{\max}}$ .

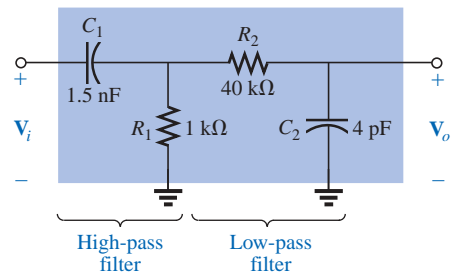

**FIG. 23.30**  
Pass-band filter.

**EXAMPLE 23.7** For the pass-band filter of Fig. 23.30:

- Determine the critical frequencies for the low- and high-pass filters.
- Using only the critical frequencies, sketch the response characteristics.
- Determine the actual value of  $V_o$  at the high-pass critical frequency calculated in part (a), and compare it to the level that will define the upper frequency for the pass-band.

**Solutions:**

- a. High-pass filter:

$$f_c = \frac{1}{2\pi R_1 C_1} = \frac{1}{2\pi(1 \text{ k}\Omega)(1.5 \text{ nF})} = \mathbf{106.1 \text{ kHz}}$$

- Low-pass filter:

$$f_c = \frac{1}{2\pi R_2 C_2} = \frac{1}{2\pi(40 \text{ k}\Omega)(4 \text{ pF})} = \mathbf{994.72 \text{ kHz}}$$

- In the mid-region of the pass-band at about 500 kHz, an analysis of the network will reveal that  $V_o \cong 0.9V_i$  as shown in Fig. 23.31. The bandwidth is therefore defined at a level of  $0.707(0.9V_i) = 0.636V_i$  as also shown in Fig. 23.31.
- At  $f = 994.72 \text{ kHz}$ ,

$$X_{C_1} = \frac{1}{2\pi f C_1} \cong 107 \Omega$$

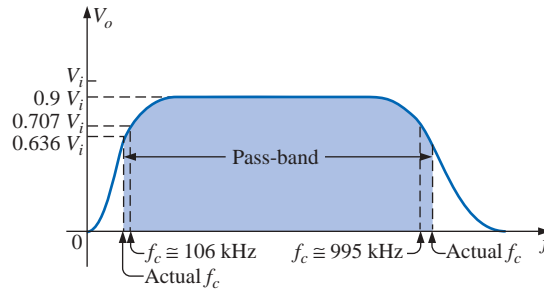
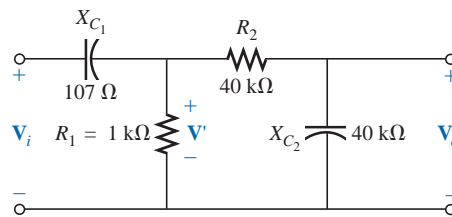

**FIG. 23.31**

Pass-band characteristics for the filter of Fig. 23.30.

and 
$$X_{C_2} = \frac{1}{2\pi f C_2} = R_2 = 40 \text{ k}\Omega$$

resulting in the network of Fig. 23.32.



**FIG. 23.32**

Network of Fig. 23.30 at  $f = 994.72 \text{ kHz}$ .

The parallel combination  $R_1 \parallel (R_2 - jX_{C_2})$  is essentially  $0.976 \text{ k}\Omega \angle 0^\circ$  because the  $R_2 - X_{C_2}$  combination is so large compared to the parallel resistor  $R_1$ .

Then

$$\mathbf{V}' = \frac{0.976 \text{ k}\Omega \angle 0^\circ (\mathbf{V}_i)}{0.976 \text{ k}\Omega - j0.107 \text{ k}\Omega} \cong 0.994 \mathbf{V}_i \angle 6.26^\circ$$

with

$$\mathbf{V}_o = \frac{(40 \text{ k}\Omega \angle -90^\circ)(0.994 \mathbf{V}_i \angle 6.26^\circ)}{40 \text{ k}\Omega - j40 \text{ k}\Omega}$$

$$\mathbf{V}_o \cong 0.703 \mathbf{V}_i \angle -39^\circ$$

so that

$$V_o \cong 0.703 V_i \quad \text{at } f = 994.72 \text{ kHz}$$

Since the bandwidth is defined at  $0.636 V_i$  the upper cutoff frequency will be higher than  $994.72 \text{ kHz}$  as shown in Fig. 23.31.

The pass-band response can also be obtained using the series and parallel resonant circuits discussed in Chapter 20. In each case, however,  $V_o$  will not be equal to  $V_i$  in the pass-band, but a frequency range in which  $V_o$  will be equal to or greater than  $0.707 V_{\text{max}}$  can be defined.

For the series resonant circuit of Fig. 23.33,  $X_L = X_C$  at resonance, and

$$\boxed{V_{o\text{max}} = \frac{R}{R + R_l} V_i} \quad f = f_s \tag{23.21}$$

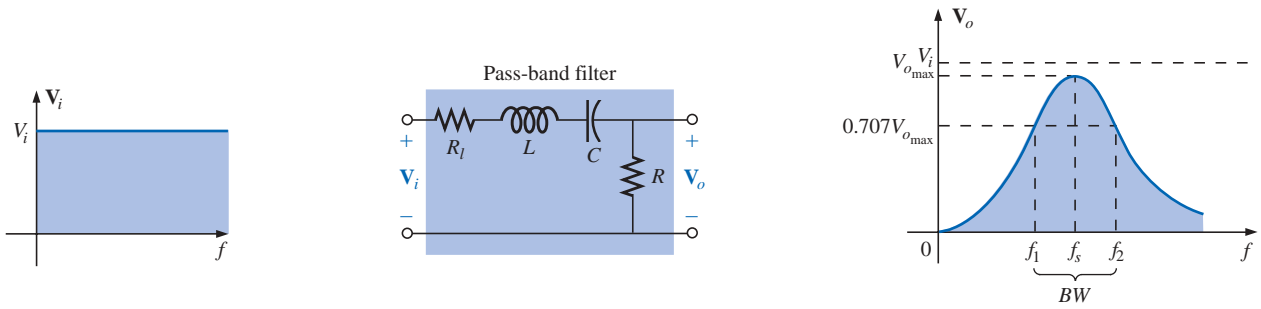

**FIG. 23.33**  
Series resonant pass-band filter.

and 
$$f_s = \frac{1}{2\pi\sqrt{LC}} \quad (23.22)$$

with 
$$Q_s = \frac{X_L}{R + R_l} \quad (23.23)$$

and 
$$BW = \frac{f_s}{Q_s} \quad (23.24)$$

For the parallel resonant circuit of Fig. 23.34,  $Z_{T_p}$  is a maximum value at resonance, and

$$V_{o,max} = \frac{Z_{T_p} V_i}{Z_{T_p} + R} \quad f = f_p \quad (23.25)$$

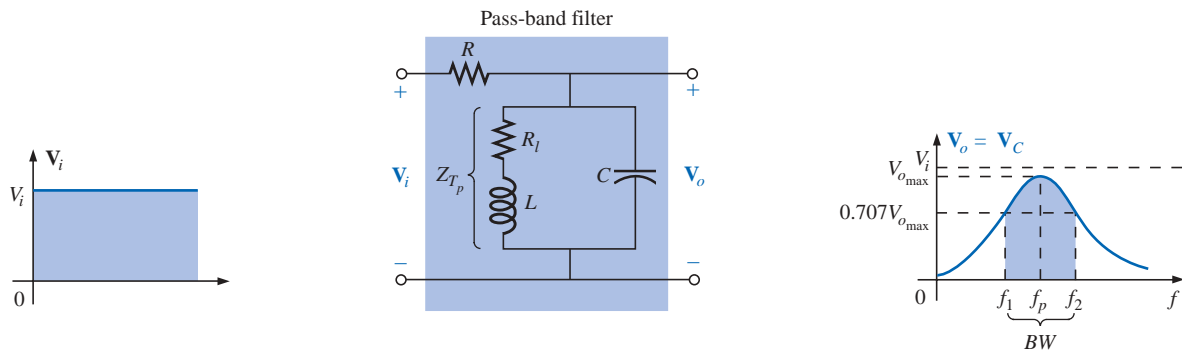

**FIG. 23.34**  
Parallel resonant pass-band filter.

with 
$$Z_{T_p} = Q_l^2 R_l \quad Q_l \geq 10 \quad (23.26)$$

and 
$$f_p = \frac{1}{2\pi\sqrt{LC}} \quad Q_l \geq 10 \quad (23.27)$$

For the parallel resonant circuit

$$Q_p = \frac{X_L}{R_l} \quad (23.28)$$

and

$$BW = \frac{f_p}{Q_p} \quad (23.29)$$

As a first approximation that is acceptable for most practical applications, it can be assumed that the resonant frequency bisects the bandwidth.

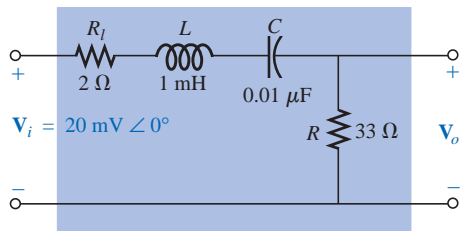

**FIG. 23.35**  
Series resonant pass-band filter for  
Example 23.8.

### EXAMPLE 23.8

- Determine the frequency response for the voltage  $V_o$  for the series circuit of Fig. 23.35.
- Plot the normalized response  $A_v = V_o/V_i$ .
- Plot a normalized response defined by  $A'_v = A_v/A_{v_{\max}}$ .

#### Solutions:

$$a. f_s = \frac{1}{2\pi\sqrt{LC}} = \frac{1}{2\pi\sqrt{(1 \text{ mH})(0.01 \text{ } \mu\text{F})}} = 50,329.21 \text{ Hz}$$

$$Q_s = \frac{X_L}{R + R_l} = \frac{2\pi(50,329.21 \text{ Hz})(1 \text{ mH})}{33 \text{ } \Omega + 2 \text{ } \Omega} = 9.04$$

$$BW = \frac{f_s}{Q_s} = \frac{50,329.21 \text{ Hz}}{9.04} = 5.57 \text{ kHz}$$

At resonance:

$$V_{o_{\max}} = \frac{RV_i}{R + R_l} = \frac{33 \text{ } \Omega(V_i)}{33 \text{ } \Omega + 2 \text{ } \Omega} = 0.943V_i = 0.943(20 \text{ mV}) \\ = 18.86 \text{ mV}$$

At the cutoff frequencies:

$$V_o = (0.707)(0.943V_i) = 0.667V_i = 0.667(20 \text{ mV}) \\ = 13.34 \text{ mV}$$

Note Fig. 23.36.

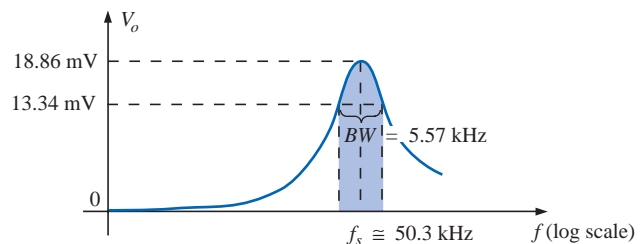

**FIG. 23.36**  
Pass-band response for the network.

- Dividing all levels of Fig. 23.36 by  $V_i = 20 \text{ mV}$  will result in the normalized plot of Fig. 23.37(a).

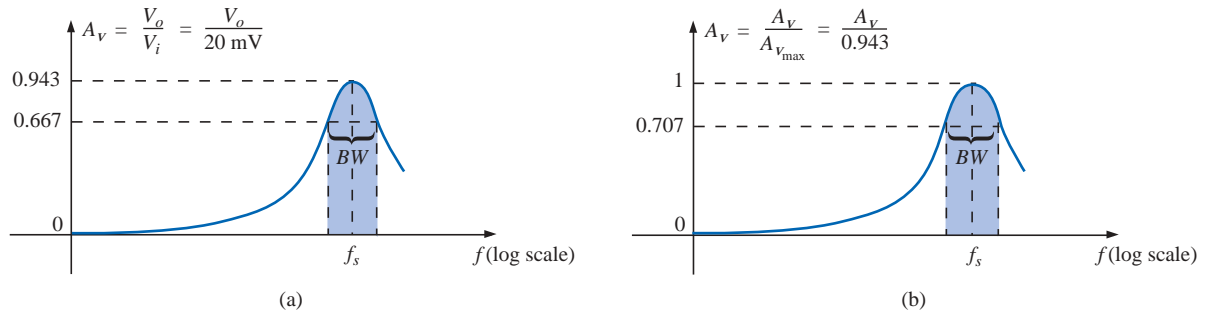

FIG. 23.37

Normalized plots for the pass-band filter of Fig. 23.35.

- c. Dividing all levels of Fig. 23.37(a) by  $A_{v_{max}} = 0.943$  will result in the normalized plot of Fig. 23.37(b).

### 23.8 STOP-BAND FILTERS

Stop-band filters can also be constructed using a low-pass and a high-pass filter. However, rather than the cascaded configuration used for the pass-band filter, a parallel arrangement is required, as shown in Fig. 23.38. A low-frequency  $f_1$  can pass through the low-pass filter, and a higher-frequency  $f_2$  can use the parallel path, as shown in Figs. 23.38 and 23.39. However, a frequency such as  $f_o$  in the reject-band is higher than the low-pass critical frequency and lower than the high-pass critical frequency, and is therefore prevented from contributing to the levels of  $V_o$  above  $0.707V_{max}$ .

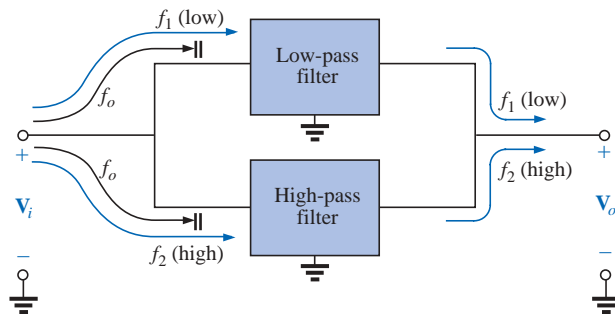

FIG. 23.38

Stop-band filter.

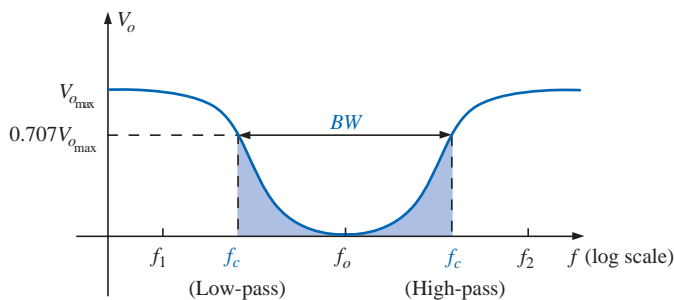
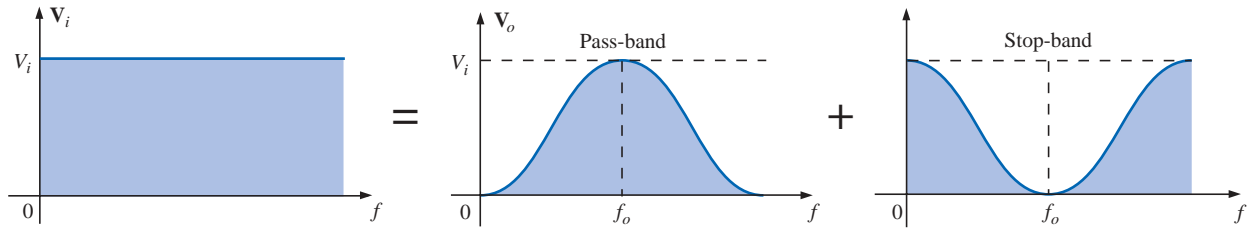

FIG. 23.39

Stop-band characteristics.

Since the characteristics of a stop-band filter are the inverse of the pattern obtained for the pass-band filters, we can employ the fact that at any frequency the sum of the magnitudes of the two waveforms to the right of the equals sign in Fig. 23.40 will equal the applied voltage  $V_i$ .

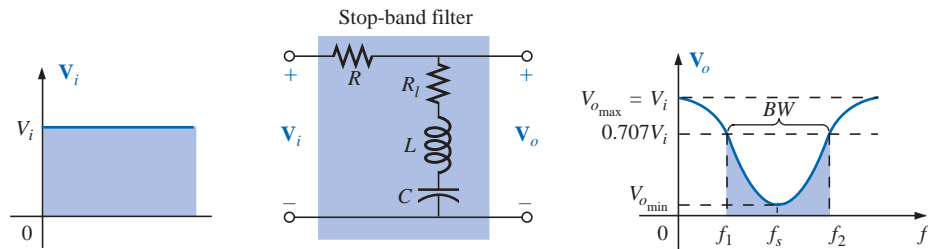

**FIG. 23.40**

*Demonstrating how an applied signal of fixed magnitude can be broken down into a pass-band and stop-band response curve.*

For the pass-band filters of Figs. 23.33 and 23.34, therefore, if we take the output off the other series elements as shown in Figs. 23.41 and 23.42, a stop-band characteristic will be obtained, as required by Kirchhoff's voltage law.

For the series resonant circuit of Fig. 23.41, Equations (23.22) through (23.24) still apply, but now, at resonance,



**FIG. 23.41**

*Stop-band filter using a series resonant circuit.*

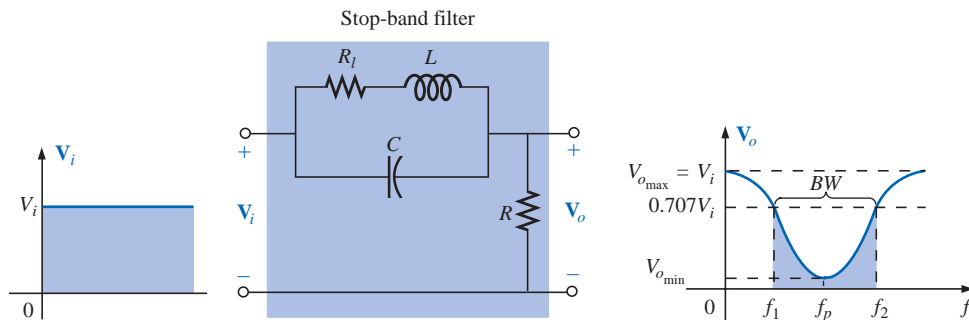

**FIG. 23.42**

*Stop-band filter using a parallel resonant network.*

$$V_{o_{\min}} = \frac{R_i V_i}{R_i + R} \quad (23.30)$$

For the parallel resonant circuit of Fig. 23.42, Equations (23.26) through (23.29) are still applicable, but now, at resonance,

$$V_{o_{\min}} = \frac{R V_i}{R + Z_{T_p}} \quad (23.31)$$

The maximum value of  $V_o$  for the series resonant circuit is  $V_i$  at the low end due to the open-circuit equivalent for the capacitor and  $V_i$  at the high end due to the high impedance of the inductive element.

For the parallel resonant circuit, at  $f = 0$  Hz, the coil can be replaced by a short-circuit equivalent, and the capacitor can be replaced by its open circuit and  $V_o = R V_i / (R + R_i)$ . At the high-frequency end, the capacitor approaches a short-circuit equivalent, and  $V_o$  increases toward  $V_i$ .

## 23.9 DOUBLE-TUNED FILTER

Some network configurations display both a pass-band and a stop-band characteristic, such as shown in Fig. 23.43. Such networks are called **double-tuned filters**. For the network of Fig. 23.43(a), the parallel resonant circuit will establish a stop-band for the range of frequencies not permitted to establish a significant  $V_L$ . The greater part of the applied voltage will appear across the parallel resonant circuit for this frequency range due to its very high impedance compared with  $R_L$ . For the pass-band, the parallel resonant circuit is designed to be capacitive (inductive if  $L_s$  is replaced by  $C_s$ ). The inductance  $L_s$  is chosen to cancel the effects of the resulting net capacitive reactance at the resonant pass-band frequency of the tank circuit, thereby acting as a series resonant circuit. The applied voltage will then appear across  $R_L$  at this frequency.

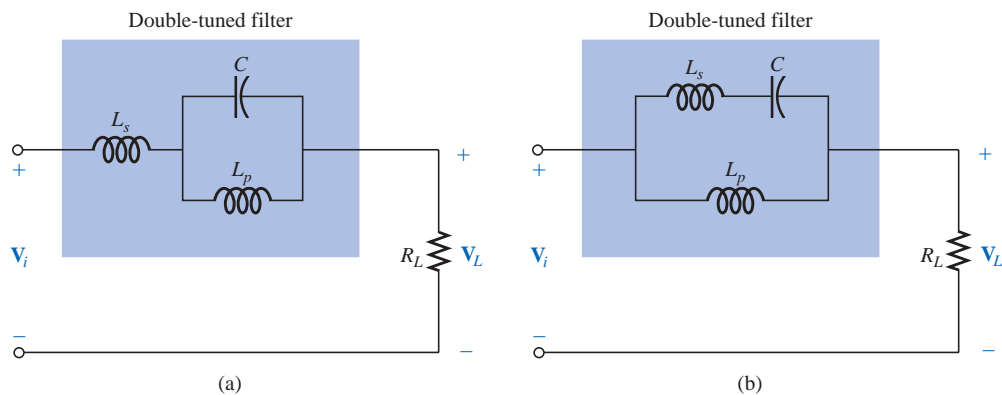

FIG. 23.43

Double-tuned networks.

For the network of Fig. 23.43(b), the series resonant circuit will still determine the pass-band, acting as a very low impedance across the parallel inductor at resonance. At the desired stop-band resonant frequency,

the series resonant circuit is capacitive. The inductance  $L_p$  is chosen to establish parallel resonance at the resonant stop-band frequency. The high impedance of the parallel resonant circuit will result in a very low load voltage  $V_L$ .

For rejected frequencies below the pass-band, the networks should appear as shown in Fig. 23.43. For the reverse situation,  $L_s$  in Fig. 23.43(a) and  $L_p$  in Fig. 23.43(b) are replaced by capacitors.

**EXAMPLE 23.9** For the network of Fig. 23.43(b), determine  $L_s$  and  $L_p$  for a capacitance  $C$  of 500 pF if a frequency of 200 kHz is to be rejected and a frequency of 600 kHz accepted.

**Solution:** For series resonance, we have

$$f_s = \frac{1}{2\pi\sqrt{LC}}$$

$$\text{and } L_s = \frac{1}{4\pi^2 f_s^2 C} = \frac{1}{4\pi^2 (600 \text{ kHz})^2 (500 \text{ pF})} = \mathbf{140.7 \mu\text{H}}$$

At 200 kHz,

$$X_{L_s} = \omega L = 2\pi f_s L_s = (2\pi)(200 \text{ kHz})(140.7 \mu\text{H}) = 176.8 \Omega$$

$$\text{and } X_C = \frac{1}{\omega C} = \frac{1}{(2\pi)(200 \text{ kHz})(500 \text{ pF})} = 1591.5 \Omega$$

For the series elements,

$$j(X_{L_s} - X_C) = j(176.8 \Omega - 1591.5 \Omega) = -j 1414.7 \Omega = -j X'_C$$

At parallel resonance ( $Q_l \geq 10$  assumed),

$$X_{L_p} = X'_C$$

$$\text{and } L_p = \frac{X_{L_p}}{\omega} = \frac{1414.7 \Omega}{(2\pi)(200 \text{ kHz})} = \mathbf{1.13 \text{ mH}}$$

The frequency response for the preceding network appears as one of the examples of PSPice in the last section of the chapter.

American (Madison, WI;  
Summit, NJ;  
Cambridge, MA)  
(1905–81)  
V.P. at Bell  
Laboratories  
Professor of Systems  
Engineering,  
Harvard University



Courtesy of AT&T Archives

In his early years at Bell Laboratories, Hendrik Bode was involved with *electric filter* and *equalizer design*. He then transferred to the Mathematics Research Group, where he specialized in research pertaining to electrical networks theory and its application to long-distance communication facilities. In 1946 he was awarded the Presidential Certificate of Merit for his work in electronic fire control devices. In addition to the publication of the book *Network Analysis and Feedback Amplifier Design* in 1945, which is considered a classic in its field, he has been granted 25 patents in electrical engineering and systems design. Upon retirement, Bode was elected Gordon McKay Professor of Systems Engineering at Harvard University. He was a fellow of the IEEE and American Academy of Arts and Sciences.

**FIG. 23.44**  
*Hendrik Wade Bode*

## 23.10 BODE PLOTS

There is a technique for sketching the frequency response of such factors as filters, amplifiers, and systems on a decibel scale that can save a great deal of time and effort and provide an excellent way to compare decibel levels at different frequencies.

*The curves obtained for the magnitude and/or phase angle versus frequency are called Bode plots (Fig. 23.44). Through the use of straight-line segments called idealized Bode plots, the frequency response of a system can be found efficiently and accurately.*

To ensure that the derivation of the method is correctly and clearly understood, the first network to be analyzed will be examined in some detail. The second network will be treated in a shorthand manner, and finally a method for quickly determining the response will be introduced.

## High-Pass R-C Filter

Let us start by reexamining the high-pass filter of Fig. 23.45. The high-pass filter was chosen as our starting point because the frequencies of primary interest are at the low end of the frequency spectrum.

The voltage gain of the system is given by

$$\begin{aligned} \mathbf{A}_v &= \frac{\mathbf{V}_o}{\mathbf{V}_i} = \frac{R}{R - jX_C} = \frac{1}{1 - j\frac{X_C}{R}} = \frac{1}{1 - j\frac{1}{2\pi fCR}} \\ &= \frac{1}{1 - j\left(\frac{1}{2\pi RC}\right)\frac{1}{f}} \end{aligned}$$

If we substitute

$$f_c = \frac{1}{2\pi RC} \quad (23.32)$$

which we recognize as the cutoff frequency of earlier sections, we obtain

$$\mathbf{A}_v = \frac{1}{1 - j(f_c/f)} \quad (23.33)$$

We will find in the analysis to follow that the ability to reformat the gain to one having the general characteristics of Eq. (23.33) is critical to the application of the Bode technique. Different configurations will result in variations of the format of Eq. (23.33), but the desired similarities will become obvious as we progress through the material.

In magnitude and phase form:

$$\mathbf{A}_v = \frac{\mathbf{V}_o}{\mathbf{V}_i} = A_v \angle \theta = \frac{1}{\sqrt{1 + (f_c/f)^2}} \angle \tan^{-1}(f_c/f) \quad (23.34)$$

providing an equation for the magnitude and phase of the high-pass filter in terms of the frequency levels.

Using Eq. (23.12),

$$A_{v_{dB}} = 20 \log_{10} A_v$$

and, substituting the magnitude component of Eq. (23.34),

$$A_{v_{dB}} = 20 \log_{10} \frac{1}{\sqrt{1 + (f_c/f)^2}} = \underbrace{20 \log_{10} 1}_0 - 20 \log_{10} \sqrt{1 + (f_c/f)^2}$$

and

$$A_{v_{dB}} = -20 \log_{10} \sqrt{1 + \left(\frac{f_c}{f}\right)^2}$$

Recognizing that  $\log_{10} \sqrt{x} = \log_{10} x^{1/2} = \frac{1}{2} \log_{10} x$ , we have

$$\begin{aligned} A_{v_{dB}} &= -\frac{1}{2} (20) \log_{10} \left[ 1 + \left(\frac{f_c}{f}\right)^2 \right] \\ &= -10 \log_{10} \left[ 1 + \left(\frac{f_c}{f}\right)^2 \right] \end{aligned}$$

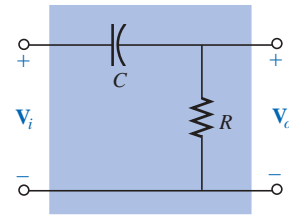

FIG. 23.45  
High-pass filter.

For frequencies where  $f \ll f_c$  or  $(f_c/f)^2 \gg 1$ ,

$$1 + \left(\frac{f_c}{f}\right)^2 \cong \left(\frac{f_c}{f}\right)^2$$

and 
$$A_{v_{dB}} = -10 \log_{10} \left(\frac{f_c}{f}\right)^2$$

but 
$$\log_{10} x^2 = 2 \log_{10} x$$

resulting in 
$$A_{v_{dB}} = -20 \log_{10} \frac{f_c}{f}$$

However, logarithms are such that

$$-\log_{10} b = +\log_{10} \frac{1}{b}$$

and substituting  $b = f_c/f$ , we have

$$\boxed{A_{v_{dB}} = +20 \log_{10} \frac{f}{f_c}} \quad f \ll f_c \quad (23.35)$$

First note the similarities between Eq. (23.35) and the basic equation for gain in decibels:  $G_{dB} = 20 \log_{10} V_o/V_i$ . The comments regarding changes in decibel levels due to changes in  $V_o/V_i$  can therefore be applied here also, except now a change in frequency by a 2:1 ratio will result in a 6-dB change in gain. A change in frequency by a 10:1 ratio will result in a 20-dB change in gain.

**Two frequencies separated by a 2:1 ratio are said to be an octave apart.**

**For Bode plots, a change in frequency by one octave will result in a 6-dB change in gain.**

**Two frequencies separated by a 10:1 ratio are said to be a decade apart.**

**For Bode plots, a change in frequency by one decade will result in a 20-dB change in gain.**

One may wonder about all the mathematical development to obtain an equation that initially appears confusing and of limited value. As specified, Equation (23.35) is accurate only for frequency levels much less than  $f_c$ .

First, realize that the mathematical development of Eq. (23.35) will not have to be repeated for each configuration encountered. Second, the equation itself is seldom applied but simply used in a manner to be described to define a straight line on a log plot that permits a sketch of the frequency response of a system with a minimum of effort and a high degree of accuracy.

To plot Eq. (23.35), consider the following levels of increasing frequency:

$$\text{For } f = f_c/10, \quad f/f_c = 0.1 \quad \text{and} \quad +20 \log_{10} 0.1 = -20 \text{ dB}$$

$$\text{For } f = f_c/4, \quad f/f_c = 0.25 \quad \text{and} \quad +20 \log_{10} 0.25 = -12 \text{ dB}$$

$$\text{For } f = f_c/2, \quad f/f_c = 0.51 \quad \text{and} \quad +20 \log_{10} 0.5 = -6 \text{ dB}$$

$$\text{For } f = f_c, \quad f/f_c = 1 \quad \text{and} \quad +20 \log_{10} 1 = 0 \text{ dB}$$

Note from the above equations that as the frequency of interest approaches  $f_c$ , the dB gain becomes less negative and approaches the final normalized value of 0 dB. The positive sign in front of Eq. (23.35) can therefore be interpreted as an indication that the dB gain will have a positive slope with an increase in frequency. A plot of these points on a log scale will result in the straight-line segment of Fig. 23.46 to the left of  $f_c$ .

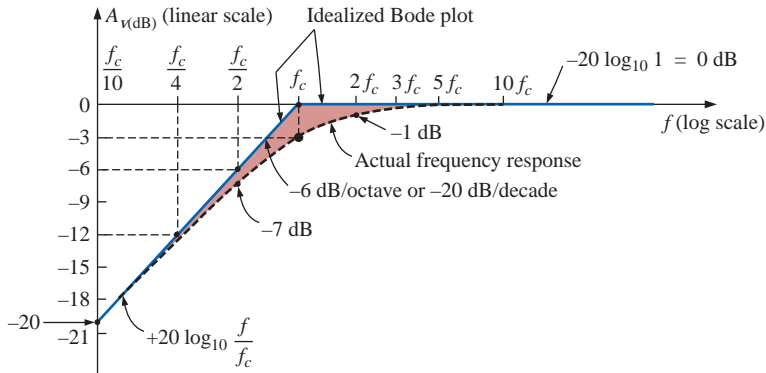

FIG. 23.46

*Idealized Bode plot for the low-frequency region.*

For the future, note that the resulting plot is a straight line intersecting the 0-dB line at  $f_c$ . It increases to the right at a rate of +6 dB per octave or +20 dB per decade. In other words, once  $f_c$  is determined, find  $f_c/2$ , and a plot point exists at -6 dB (or find  $f_c/10$ , and a plot point exists at -20 dB).

***Bode plots are straight-line segments because the dB change per decade or octave is constant.***

The actual response will approach an asymptote (straight-line segment) defined by  $A_{v\text{dB}} = 0$  dB since at high frequencies

$$f \gg f_c \quad \text{and} \quad f_c/f \cong 0$$

$$\begin{aligned} \text{with} \quad A_{v\text{dB}} &= 20 \log_{10} \frac{1}{\sqrt{1 + (f_c/f)^2}} = 20 \log_{10} \frac{1}{\sqrt{1 + 0}} \\ &= 20 \log_{10} 1 = 0 \text{ dB} \end{aligned}$$

The two asymptotes defined above will intersect at  $f_c$ , as shown in Fig. 23.46, forming an envelope for the actual frequency response.

At  $f = f_c$ , the cutoff frequency,

$$\begin{aligned} A_{v\text{dB}} &= 20 \log_{10} \frac{1}{\sqrt{1 + (f_c/f)^2}} = 20 \log_{10} \frac{1}{\sqrt{1 + 1}} = 20 \log_{10} \frac{1}{\sqrt{2}} \\ &= -3 \text{ dB} \end{aligned}$$

At  $f = 2f_c$ ,

$$\begin{aligned} A_{v\text{dB}} &= -20 \log_{10} \sqrt{1 + \left(\frac{f_c}{2f_c}\right)^2} = -20 \log_{10} \sqrt{1 + \left(\frac{1}{2}\right)^2} \\ &= -20 \log_{10} \sqrt{1.25} = -1 \text{ dB} \end{aligned}$$

as shown in Fig. 23.46.

At  $f = f_c/2$ ,

$$\begin{aligned} A_{\text{vdB}} &= -20 \log_{10} \sqrt{1 + \left(\frac{f_c}{f_c/2}\right)^2} = -20 \log_{10} \sqrt{1 + (2)^2} \\ &= -20 \log_{10} \sqrt{5} \\ &= -7 \text{ dB} \end{aligned}$$

separating the idealized Bode plot from the actual response by 7 dB – 6 dB = 1 dB, as shown in Fig. 23.46.

Reviewing the above,

*at  $f = f_c$ , the actual response curve is 3 dB down from the idealized Bode plot, whereas at  $f = 2f_c$  and  $f_c/2$ , the actual response curve is 1 dB down from the asymptotic response.*

The phase response can also be sketched using straight-line asymptotes by considering a few critical points in the frequency spectrum.

Equation (23.34) specifies the phase response (the angle by which  $\mathbf{V}_o$  leads  $\mathbf{V}_i$ ) by

$$\theta = \tan^{-1} \frac{f_c}{f} \quad (23.36)$$

For frequencies well below  $f_c$  ( $f \ll f_c$ ),  $\theta = \tan^{-1}(f_c/f)$  approaches  $90^\circ$  and for frequencies well above  $f_c$  ( $f \gg f_c$ ),  $\theta = \tan^{-1}(f_c/f)$  will approach  $0^\circ$ , as discovered in earlier sections of the chapter. At  $f = f_c$ ,  $\theta = \tan^{-1}(f_c/f) = \tan^{-1} 1 = 45^\circ$ .

Defining  $f \ll f_c$  for  $f = f_c/10$  (and less) and  $f \gg f_c$  for  $f = 10f_c$  (and more), we can define

*an asymptote at  $\theta = 90^\circ$  for  $f \ll f_c/10$ , an asymptote at  $\theta = 0^\circ$  for  $f \gg 10f_c$ , and an asymptote from  $f_c/10$  to  $10f_c$  that passes through  $\theta = 45^\circ$  at  $f = f_c$ .*

The asymptotes defined above all appear in Fig. 23.47. Again, the Bode plot for Eq.(23.36) is a straight line because the change in phase angle will be  $45^\circ$  for every tenfold change in frequency.

Substituting  $f = f_c/10$  into Eq. (23.36),

$$\theta = \tan^{-1} \left( \frac{f_c}{f_c/10} \right) = \tan^{-1} 10 = 84.29^\circ$$

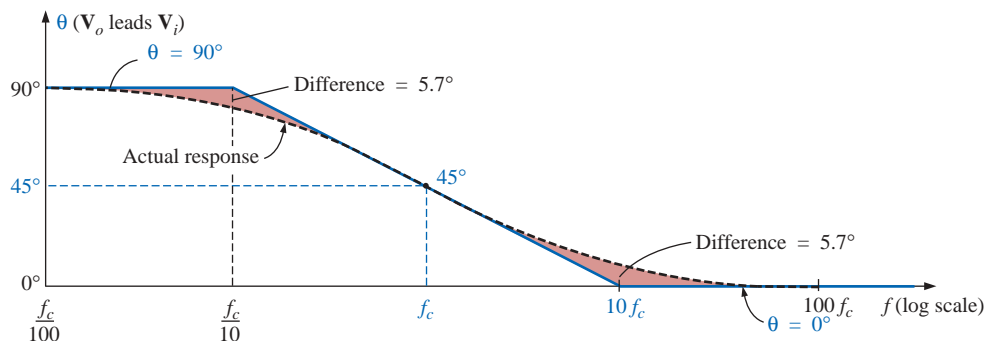

FIG. 23.47

Phase response for a high-pass R-C filter.

for a difference of  $90^\circ - 84.29^\circ \cong 5.7^\circ$  from the idealized response.

Substituting  $f = 10f_c$ ,

$$\theta = \tan^{-1}\left(\frac{f_c}{10f_c}\right) = \tan^{-1}\frac{1}{10} \cong 5.7^\circ$$

In summary, therefore,

*at  $f = f_c$ ,  $\theta = 45^\circ$ , whereas at  $f = f_c/10$  and  $10f_c$ , the difference between the actual phase response and the asymptotic plot is  $5.7^\circ$ .*

### EXAMPLE 23.10

- Sketch  $A_{v_{dB}}$  versus frequency for the high-pass  $R$ - $C$  filter of Fig. 23.48.
- Determine the decibel level at  $f = 1$  kHz.
- Sketch the phase response versus frequency on a log scale.

#### Solutions:

$$\text{a. } f_c = \frac{1}{2\pi RC} = \frac{1}{(2\pi)(1 \text{ k}\Omega)(0.1 \text{ }\mu\text{F})} = 1591.55 \text{ Hz}$$

The frequency  $f_c$  is identified on the log scale as shown in Fig. 23.49. A straight line is then drawn from  $f_c$  with a slope that will intersect  $-20$  dB at  $f_c/10 = 159.15$  Hz or  $-6$  dB at  $f_c/2 = 795.77$  Hz. A second asymptote is drawn from  $f_c$  to higher frequencies at  $0$  dB. The actual response curve can then be drawn through the  $-3$ -dB level at  $f_c$  approaching the two asymptotes of Fig. 23.49. Note the 1-dB difference between the actual response and the idealized Bode plot at  $f = 2f_c$  and  $0.5f_c$ .

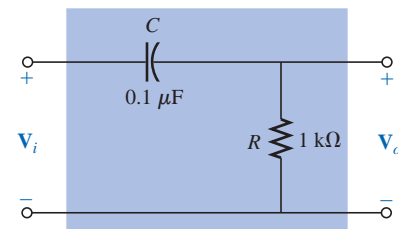

**FIG. 23.48**  
Example 23.10.

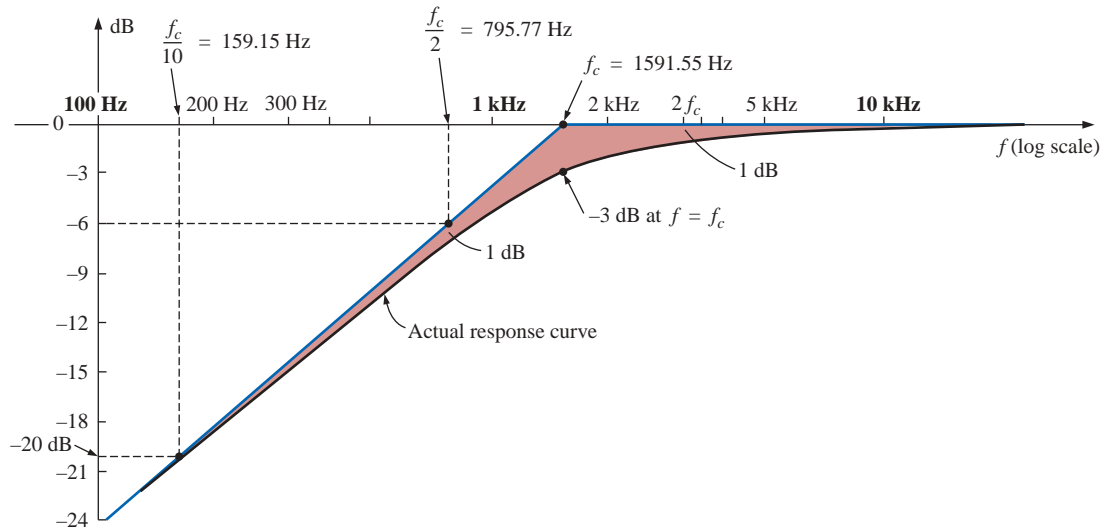

**FIG. 23.49**

Frequency response for the high-pass filter of Fig. 23.48.

Note that in the solution to part (a), there is no need to employ Eq. (23.35) or to perform any extensive mathematical manipulations.

b. Eq. (23.33):

$$|A_{vdB}| = 20 \log_{10} \frac{1}{\sqrt{1 + \left(\frac{f_c}{f}\right)^2}} = 20 \log_{10} \frac{1}{\sqrt{1 + \left(\frac{1591.55 \text{ Hz}}{1000}\right)^2}}$$

$$= 20 \log_{10} \frac{1}{\sqrt{1 + (1.592)^2}} = 20 \log_{10} 0.5318 = -5.49 \text{ dB}$$

as verified by Fig. 23.49.

c. See Fig. 23.50. Note that  $\theta = 45^\circ$  at  $f = f_c = 1591.55 \text{ Hz}$ , and the difference between the straight-line segment and the actual response is  $5.7^\circ$  at  $f = f_c/10 = 159.2 \text{ Hz}$  and  $f = 10f_c = 15,923.6 \text{ Hz}$ .

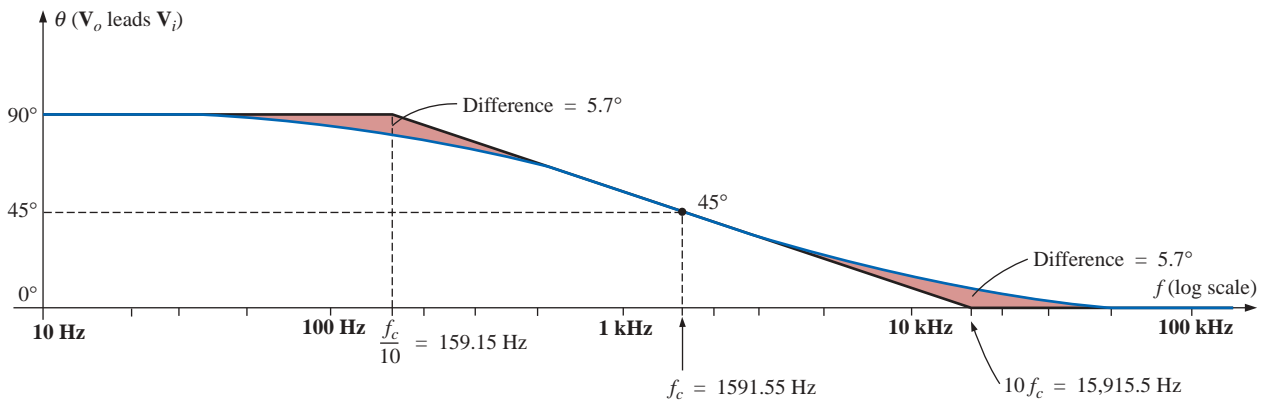

FIG. 23.50

Phase plot for the high-pass R-C filter.

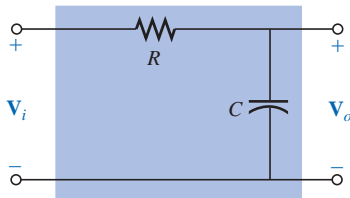

FIG. 23.51  
Low-pass filter.

### Low-Pass R-C Filter

For the low-pass filter of Fig. 23.51,

$$A_v = \frac{V_o}{V_i} = \frac{-jX_C}{R - jX_C} = \frac{1}{\frac{R}{-jX_C} + 1}$$

$$= \frac{1}{1 + j\frac{R}{X_C}} = \frac{1}{1 + j\frac{R}{\frac{1}{2\pi fC}}} = \frac{1}{1 + j\frac{f}{\frac{1}{2\pi RC}}}$$

and

$$A_v = \frac{1}{1 + j(f/f_c)} \tag{23.37}$$

with

$$f_c = \frac{1}{2\pi RC} \tag{23.38}$$

as defined earlier.

Note that now the sign of the imaginary component in the denominator is positive and  $f_c$  appears in the denominator of the frequency ratio rather than in the numerator, as in the case of  $f_c$  for the high-pass filter.

In terms of magnitude and phase,

$$A_v = \frac{V_o}{V_i} = A_v \angle \theta = \frac{1}{\sqrt{1 + (f/f_c)^2}} \angle -\tan^{-1}(f/f_c) \quad (23.39)$$

An analysis similar to that performed for the high-pass filter will result in

$$A_{v_{dB}} = -20 \log_{10} \frac{f}{f_c} \quad f \gg f_c \quad (23.40)$$

Note in particular that the equation is exact only for frequencies much greater than  $f_c$ , but a plot of Eq. (23.40) does provide an asymptote that performs the same function as the asymptote derived for the high-pass filter. In addition, note that it is exactly the same as Eq. (23.35), except for the minus sign, which suggests that the resulting Bode plot will have a negative slope [recall the positive slope for Eq. (23.35)] for increasing frequencies beyond  $f_c$ .

A plot of Eq. (23.40) appears in Fig. 23.52 for  $f_c = 1$  kHz. Note the 6-dB drop at  $f = 2f_c$  and the 20-dB drop at  $f = 10f_c$ .

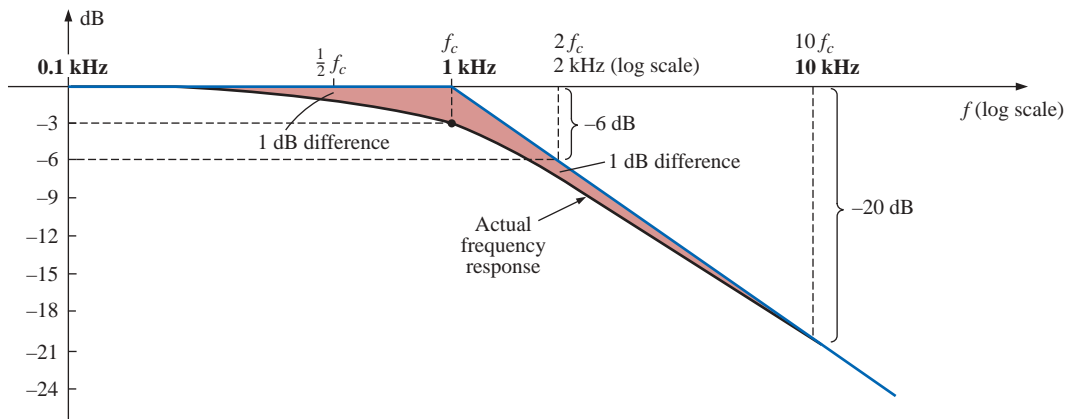

FIG. 23.52

Bode plot for the high-frequency region of a low-pass R-C filter.

At  $f \gg f_c$ , the phase angle  $\theta = -\tan^{-1}(f/f_c)$  approaches  $-90^\circ$ , whereas at  $f \ll f_c$ ,  $\theta = -\tan^{-1}(f/f_c)$  approaches  $0^\circ$ . At  $f = f_c$ ,  $\theta = -\tan^{-1} 1 = -45^\circ$ , establishing the plot of Fig. 23.53. Note again the  $45^\circ$  change in phase angle for each tenfold increase in frequency.

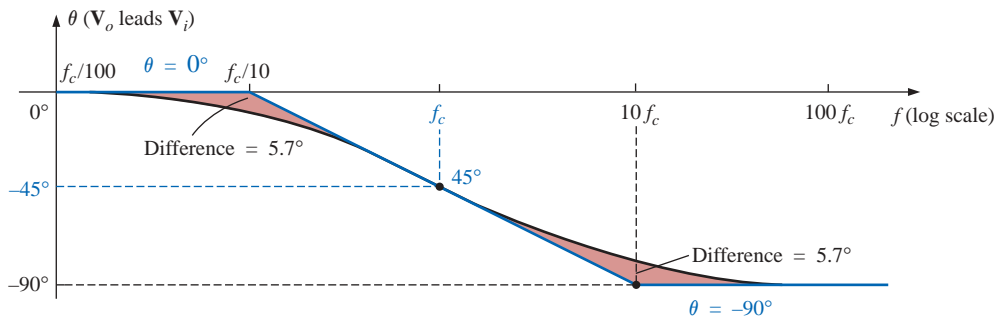

FIG. 23.53

Phase plot for a low-pass R-C filter.

Even though the preceding analysis has been limited solely to the  $R$ - $C$  combination, the results obtained will have an impact on networks that are a great deal more complicated. One good example is the high- and low-frequency response of a standard transistor configuration. Some capacitive elements in a practical transistor network will affect the low-frequency response, and others will affect the high-frequency response. In the absence of the capacitive elements, the frequency response of a transistor would ideally stay level at the midband value. However, the coupling capacitors at low frequencies and the bypass and parasitic capacitors at high frequencies will define a bandwidth for numerous transistor configurations. In the low-frequency region, specific capacitors and resistors will form an  $R$ - $C$  combination that will define a low cutoff frequency. There are then other elements and capacitors forming a second  $R$ - $C$  combination that will define a high cutoff frequency. Once the cutoff frequencies are known, the  $-3$ -dB points are set, and the bandwidth of the system can be determined.

### 23.11 SKETCHING THE BODE RESPONSE

In the previous section we found that normalized functions of the form appearing in Fig. 23.54 had the Bode envelope and the dB response

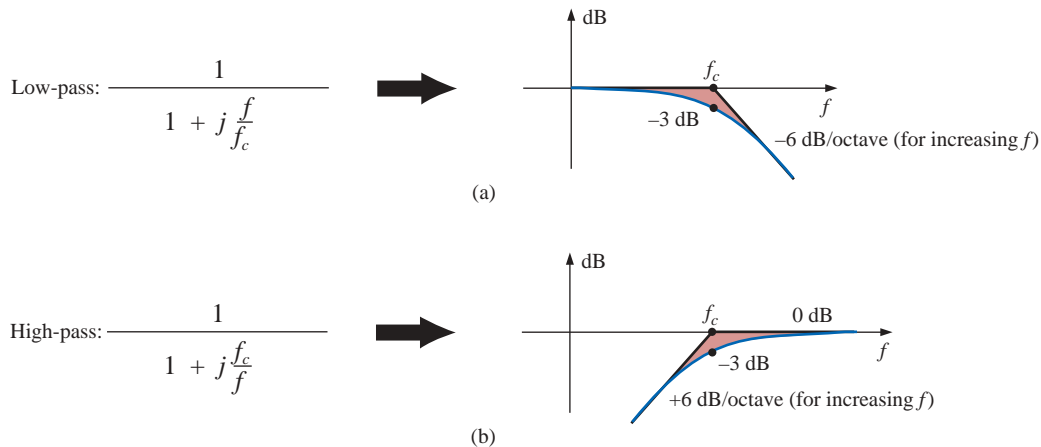

FIG. 23.54

*dB response of (a) low-pass filter and (b) high-pass filter.*

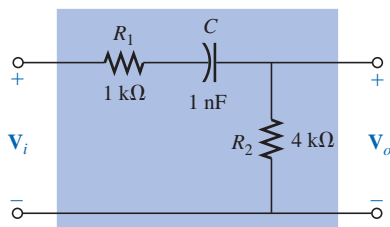

FIG. 23.55

*High-pass filter with attenuated output.*

indicated in the same figure. In this section we introduce additional functions and their responses that can be used in conjunction with those of Fig. 23.54 to determine the dB response of more sophisticated systems in a systematic, time-saving, and accurate manner.

As an avenue toward introducing an additional function that appears quite frequently, let us examine the high-pass filter of Fig. 23.55 which has a high-frequency output less than the full applied voltage.

Before developing a mathematical expression for  $\mathbf{A}_v = \mathbf{V}_o/\mathbf{V}_i$ , let us first make a rough sketch of the expected response.

At  $f = 0$  Hz, the capacitor will assume its open-circuit equivalence, and  $V_o = 0$  V. At very high frequencies, the capacitor can assume its short-circuit equivalence, and

$$V_o = \frac{R_2}{R_1 + R_2} V_i = \frac{4 \text{ k}\Omega}{1 \text{ k}\Omega + 4 \text{ k}\Omega} V_i = 0.8V_i$$

The resistance to be employed in the equation for cutoff frequency can be determined by simply determining the Thévenin resistance “seen” by the capacitor. Setting  $V_i = 0$  V and solving for  $R_{Th}$  (for the capacitor  $C$ ) will result in the network of Fig. 23.56, where it is quite clear that

$$R_{Th} = R_1 + R_2 = 1 \text{ k}\Omega + 4 \text{ k}\Omega = 5 \text{ k}\Omega$$

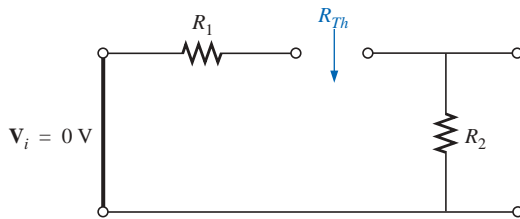

FIG. 23.56

Determining  $R_{Th}$  for the equation for cutoff frequency.

Therefore,

$$f_c = \frac{1}{2\pi R_{Th} C} = \frac{1}{2\pi(5 \text{ k}\Omega)(1 \text{ nF})} = 31.83 \text{ kHz}$$

A sketch of  $V_o$  versus frequency is provided in Fig. 23.57(a). A normalized plot using  $V_i$  as the normalizing quantity will result in the response of Fig. 23.57(b). If the maximum value of  $A_v$  is used in the normalization process, the response of Fig. 23.57(c) will be obtained.

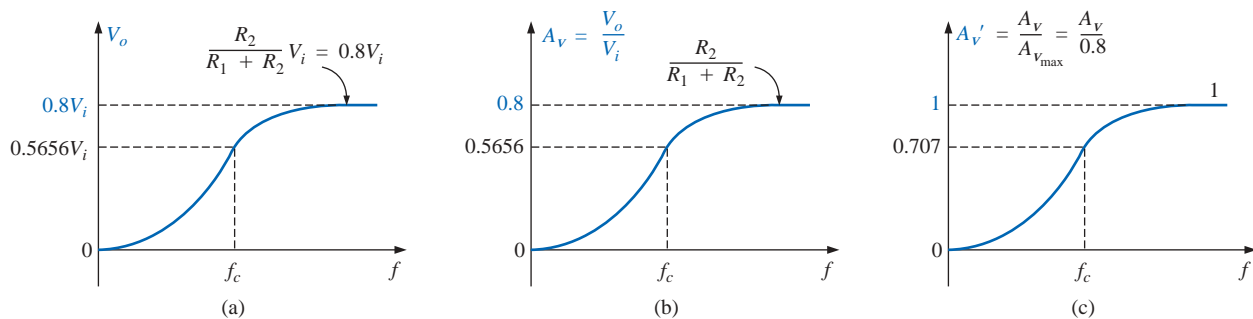

FIG. 23.57

Finding the normalized plot for the gain of the high-pass filter of Fig. 23.55 with attenuated output.

For all the plots obtained in the previous section,  $V_i$  was the maximum value, and the ratio  $V_o/V_i$  had a maximum value of 1. For many situations, this will not be the case, and we must be aware of which ratio is being plotted versus frequency. The dB response curves for the plots of Figs. 23.57(b) and 23.57(c) can both be obtained quite directly using the foundation established by the conclusions depicted in Fig. 23.54, but we must be aware of what to expect and how they will differ. In Fig. 23.57(b) we are comparing the output level to the input voltage. In

Fig. 23.57(c) we are plotting  $A_v$  versus the maximum value of  $A_v$ . On most data sheets and for the majority of the investigative techniques commonly employed, the normalized plot of Fig. 23.57(c) is used because it establishes 0 dB as an asymptote for the dB plot. To ensure that the impact of using either Fig. 23.57(b) or Fig. 23.57(c) in a frequency plot is understood, the analysis of the filter of Fig. 23.55 will include the resulting dB plot for both normalized curves.

For the network of Fig. 23.55:

$$\mathbf{V}_o = \frac{R_2 \mathbf{V}_i}{R_1 + R_2 - jX_C} = R_2 \left[ \frac{1}{R_1 + R_2 - jX_C} \right] \mathbf{V}_i$$

Dividing the top and bottom of the equation by  $R_1 + R_2$  results in

$$\mathbf{V}_o = \frac{R_2}{R_1 + R_2} \left[ \frac{1}{1 - j \frac{X_C}{R_1 + R_2}} \right]$$

$$\begin{aligned} \text{but } -j \frac{X_C}{R_1 + R_2} &= -j \frac{1}{\omega(R_1 + R_2)C} = -j \frac{1}{2\pi f(R_1 + R_2)C} \\ &= -j \frac{f_c}{f} \quad \text{with } f_c = \frac{1}{2\pi R_{Th}C} \quad \text{and } R_{Th} = R_1 + R_2 \end{aligned}$$

$$\text{so that } \mathbf{V}_o = \frac{R_2}{R_1 + R_2} \left[ \frac{1}{1 - j(f_c/f)} \right] \mathbf{V}_i$$

If we divide both sides by  $\mathbf{V}_i$ , we obtain

$$\mathbf{A}_v = \frac{\mathbf{V}_o}{\mathbf{V}_i} = \frac{R_2}{R_1 + R_2} \left[ \frac{1}{1 - j(f_c/f)} \right] \quad (23.41)$$

from which the magnitude plot of Fig. 23.57(b) can be obtained. If we divide both sides by  $\mathbf{A}_{v_{\max}} = R_2/(R_1 + R_2)$ , we have

$$\mathbf{A}'_v = \frac{\mathbf{A}_v}{\mathbf{A}_{v_{\max}}} = \frac{1}{1 - j(f_c/f)} \quad (23.42)$$

from which the magnitude plot of Fig. 23.57(c) can be obtained.

Based on the past section, a dB plot of the magnitude of  $\mathbf{A}'_v = \mathbf{A}_v/\mathbf{A}_{v_{\max}}$  is now quite direct using Fig. 23.54(b). The plot appears in Fig. 23.58.

For the gain  $A_v = V_o/V_i$ , we can apply Eq. (23.5):

$$20 \log_{10} ab = 20 \log_{10} a + 20 \log_{10} b$$

where

$$\begin{aligned} 20 \log_{10} \left\{ \frac{R_2}{R_1 + R_2} \left[ \frac{1}{1 - j(f_c/f)} \right] \right\} \\ = 20 \log_{10} \frac{R_2}{R_1 + R_2} + 20 \log_{10} \frac{1}{\sqrt{1 + (f_c/f)^2}} \end{aligned}$$

The second term will result in the same plot of Fig. 23.58, but the first term must be added to the second to obtain the total dB response.

Since  $R_2/(R_1 + R_2)$  must always be less than 1, we can rewrite the first term as

$$20 \log_{10} \frac{R_2}{R_1 + R_2} = 20 \log_{10} \frac{1}{\frac{R_1 + R_2}{R_2}} = \underbrace{20 \log_{10} 1}_0 - 20 \log_{10} \frac{R_1 + R_2}{R_2}$$

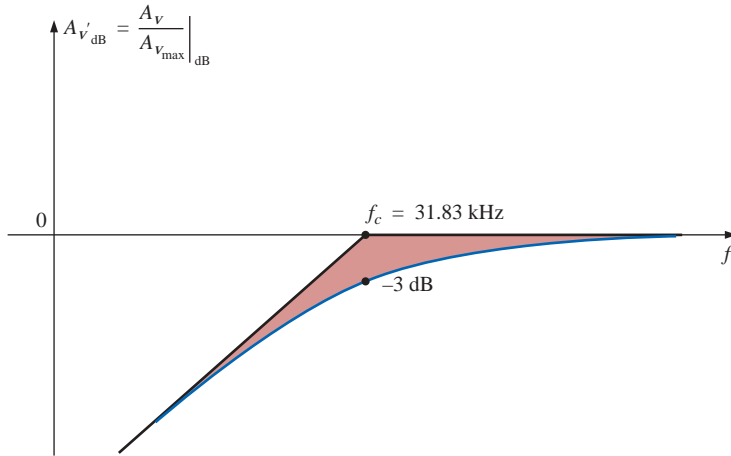

**FIG. 23.58**  
dB plot for  $A'_v$  for the high-pass filter of Fig. 23.55.

and  $20 \log_{10} \frac{R_2}{R_1 + R_2} = -20 \log_{10} \frac{R_1 + R_2}{R_2}$  **(23.43)**

providing the drop in dB from the 0-dB level for the plot. Adding one log plot to the other *at each frequency*, as permitted by Eq. (23.5), will result in the plot of Fig. 23.59.

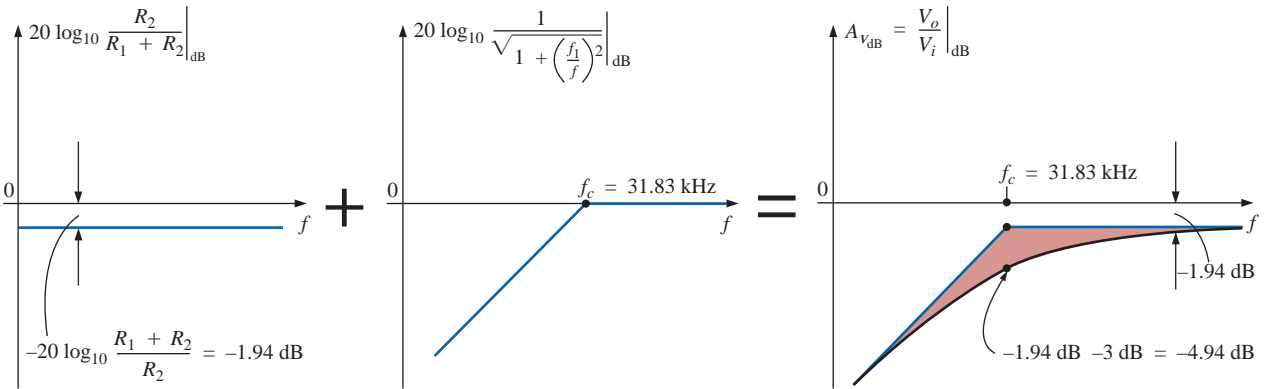

**FIG. 23.59**  
Obtaining a dB plot of  $A_{v\text{dB}} = \frac{V_o}{V_i}|_{\text{dB}}$ .

For the network of Fig. 23.55, the gain  $A_v = V_o/V_i$  can also be found in the following manner:

$$\begin{aligned}
 V_o &= \frac{R_2 V_i}{R_1 + R_2 - j X_C} \\
 A_v = \frac{V_o}{V_i} &= \frac{R_2}{R_1 + R_2 - j X_C} = \frac{j R_2}{j (R_1 + R_2) + X_C} = \frac{j R_2 / X_C}{j (R_1 + R_2) / X_C + 1} \\
 &= \frac{j \omega R_2 C}{1 + j \omega (R_1 + R_2) C} = \frac{j 2\pi f R_2 C}{1 + j 2\pi f (R_1 + R_2) C}
 \end{aligned}$$

and

$$\mathbf{A}_v = \frac{\mathbf{V}_o}{\mathbf{V}_i} = \frac{j(f/f_1)}{1 + j(f/f_c)} \quad (23.44)$$

$$\text{with } f_1 = \frac{1}{2\pi R_2 C} \quad \text{and} \quad f_c = \frac{1}{2\pi(R_1 + R_2)C}$$

The bottom of Eq. (23.44) is a match of the denominator of the low-pass function of Fig. 23.54(a). The numerator, however, is a new function that will define a unique Bode asymptote that will prove useful for a variety of network configurations.

Applying Eq. (23.5):

$$\begin{aligned} 20 \log_{10} \frac{V_o}{V_i} &= 20 \log_{10} \left[ \frac{f}{f_1} \right] \left[ \frac{1}{\sqrt{1 + (f/f_c)^2}} \right] \\ &= 20 \log_{10}(f/f_1) + 20 \log_{10} \frac{1}{\sqrt{1 + (f/f_c)^2}} \end{aligned}$$

Let us now consider specific frequencies for the first term.

At  $f = f_1$ :

$$20 \log_{10} \frac{f}{f_1} = 20 \log_{10} 1 = 0 \text{ dB}$$

At  $f = 2f_1$ :

$$20 \log_{10} \frac{f}{f_1} = 20 \log_{10} 2 = +6 \text{ dB}$$

At  $f = \frac{1}{2}f_1$ :

$$20 \log_{10} \frac{f}{f_1} = 20 \log_{10} 0.5 = -6 \text{ dB}$$

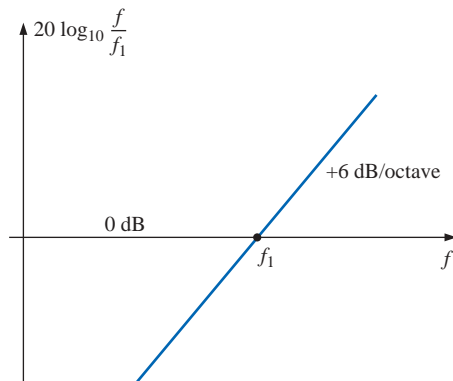

**FIG. 23.60**  
dB plot of  $f/f_1$ .

A dB plot of  $20 \log_{10}(f/f_1)$  is provided in Fig. 23.60. Note that the asymptote passes through the 0-dB line at  $f = f_1$  and has a positive slope of +6 dB/octave (or 20 dB/decade) for frequencies above and below  $f_1$  for increasing values of  $f$ .

If we examine the original function  $A_v$ , we find that the phase angle associated with  $j f/f_1 = f/f_1 \angle 90^\circ$  is fixed at  $90^\circ$ , resulting in a phase angle for  $A_v$  of  $90^\circ - \tan^{-1}(f/f_c) = +\tan^{-1}(f_c/f)$ .

Now that we have a plot of the dB response for the magnitude of the function  $f/f_1$ , we can plot the dB response of the magnitude of  $A_v$  using a procedure outlined by Fig. 23.61.

Solving for  $f_1$  and  $f_c$ :

$$f_1 = \frac{1}{2\pi R_2 C} = \frac{1}{2\pi(4 \text{ k}\Omega)(1 \text{ nF})} = 39.79 \text{ kHz}$$

$$\text{with } f_c = \frac{1}{2\pi(R_1 + R_2)C} = \frac{1}{2\pi(5 \text{ k}\Omega)(1 \text{ nF})} = 31.83 \text{ kHz}$$

For this development the straight-line asymptotes for each term resulting from the application of Eq. (23.5) will be drawn on the same frequency axis to permit an examination of the impact of one line section on the other. For clarity, the frequency spectrum of Fig. 23.61 has been divided into two regions.

In region 1 we have a 0-dB asymptote and one increasing at 6 dB/octave for increasing frequencies. The sum of the two as defined by Eq. (23.5) is simply the 6-dB/octave asymptote shown in the figure.

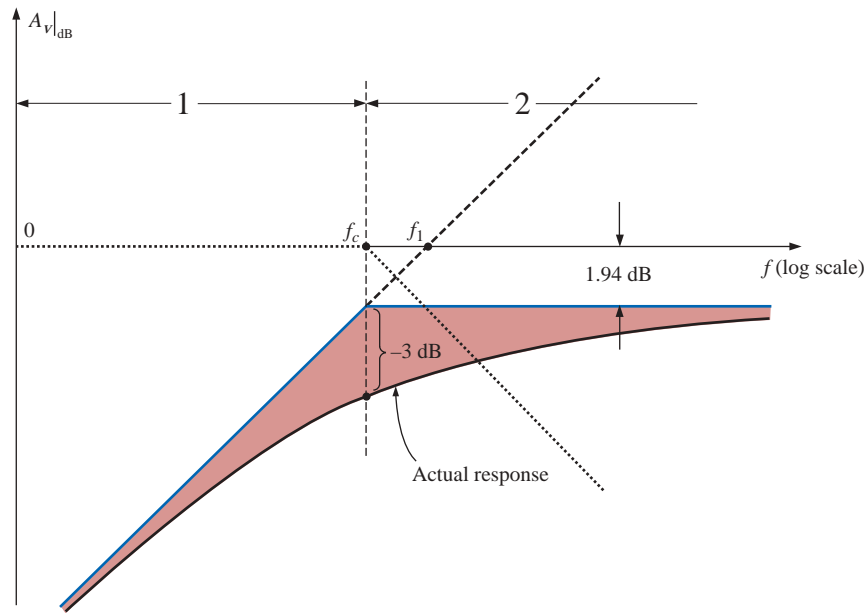

FIG. 23.61

Plot of  $A_v|_{\text{dB}}$  for the network of Fig. 23.55.

In region 2 one asymptote is increasing at 6 dB, and the other is decreasing at  $-6$  dB/octave for increasing frequencies. The net effect is that one cancels the other for the region greater than  $f = f_c$ , leaving a horizontal asymptote beginning at  $f = f_c$ . A careful sketch of the asymptotes on a log scale will reveal that the horizontal asymptote is at  $-1.94$  dB, as obtained earlier for the same function. The horizontal level can also be determined by simply plugging  $f = f_c$  into the Bode plot defined by  $f/f_1$ ; that is,

$$\begin{aligned} 20 \log \frac{f}{f_1} &= 20 \log_{10} \frac{f_c}{f_1} = 20 \log_{10} \frac{31.83 \text{ kHz}}{39.79 \text{ kHz}} \\ &= 20 \log_{10} 0.799 = -1.94 \text{ dB} \end{aligned}$$

The actual response can then be drawn using the asymptotes and the known differences at  $f = f_c$  ( $-3$  dB) and at  $f = 0.5f_c$  or  $2f_c$  ( $-1$  dB).

In summary, therefore, the same dB response for  $\mathbf{A}_v = \mathbf{V}_o/\mathbf{V}_i$  can be obtained by isolating the maximum value or defining the gain in a different form. The latter approach permitted the introduction of a new function for our catalog of idealized Bode plots that will prove useful in the future.

## 23.12 LOW-PASS FILTER WITH LIMITED ATTENUATION

Our analysis will now continue with the low-pass filter of Fig. 23.62, which has limited attenuation at the high-frequency end. That is, the output will not drop to zero as the frequency becomes relatively high. The filter is similar in construction to Fig. 23.55, but note that now  $\mathbf{V}_o$  includes the capacitive element.

At  $f = 0$  Hz, the capacitor can assume its open-circuit equivalence, and  $\mathbf{V}_o = \mathbf{V}_i$ . At high frequencies the capacitor can be approximated by a short-circuit equivalence, and

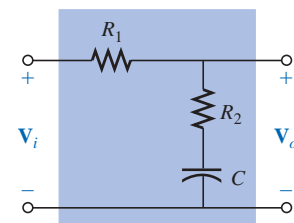
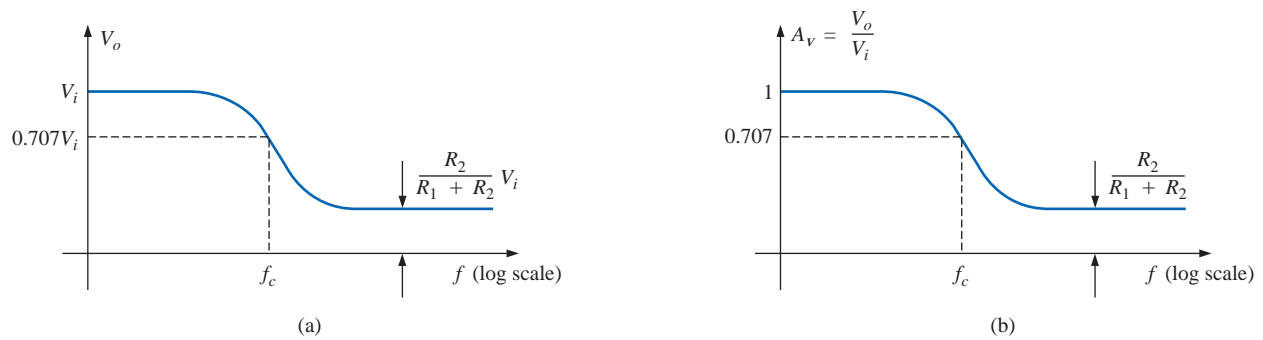

FIG. 23.62

Low-pass filter with limited attenuation.

$$\mathbf{V}_o = \frac{R_2}{R_1 + R_2} \mathbf{V}_i$$

A plot of  $V_o$  versus frequency is provided in Fig. 23.63(a). A sketch of  $A_v = V_o/V_i$  will appear as shown in Fig. 23.63(b).



**FIG. 23.63**

*Low-pass filter with limited attenuation.*

An equation for  $\mathbf{V}_o$  in terms of  $\mathbf{V}_i$  can be derived by first applying the voltage divider rule:

$$\mathbf{V}_o = \frac{(R_2 - jX_C)\mathbf{V}_i}{R_1 + R_2 - jX_C}$$

$$\begin{aligned} \text{and } \mathbf{A}_v = \frac{\mathbf{V}_o}{\mathbf{V}_i} &= \frac{R_2 - jX_C}{R_1 + R_2 - jX_C} = \frac{R_2/X_C - j}{(R_1 + R_2)/X_C - j} \\ &= \frac{(j)(R_2X_C - j)}{(j)((R_1 + R_2)/X_C - j)} \\ &= \frac{j(R_2/X_C) + 1}{j((R_1 + R_2)/X_C) + 1} = \frac{1 + j2\pi fR_2C}{1 + j2\pi f(R_1 + R_2)C} \end{aligned}$$

so that

$$\mathbf{A}_v = \frac{\mathbf{V}_o}{\mathbf{V}_i} = \frac{1 + j(f/f_1)}{1 + j(ff_c)} \quad (23.45)$$

$$\text{with } f_1 = \frac{1}{2\pi R_2 C} \quad \text{and} \quad f_c = \frac{1}{2\pi(R_1 + R_2)C}$$

The denominator of Eq. (23.45) is simply the denominator of the low-pass function of Fig. 23.54(a). The numerator, however, is new and must be investigated.

Applying Eq. (23.5):

$$A_{v_{dB}} = 20 \log_{10} \frac{V_o}{V_i} = 20 \log_{10} \sqrt{1 + (f/f_1)^2} + 20 \log_{10} \frac{1}{\sqrt{1 + (ff_c)^2}}$$

For  $f \gg f_1$ ,  $(f/f_1)^2 \gg 1$ , and the first term becomes

$$20 \log_{10} \sqrt{(f/f_1)^2} = 20 \log_{10} ((f/f_1)^2)^{1/2} = 20 \log_{10} (f/f_1) \Big|_{f \gg f_1}$$

which defines the idealized Bode asymptote for the numerator of Eq. (23.45).

At  $f = f_1$ ,  $20 \log_{10} 1 = 0$  dB, and at  $f = 2f_1$ ,  $20 \log_{10} 2 = 6$  dB. For frequencies much less than  $f_1$ ,  $(f/f_1)^2 \ll 1$ , and the first term of the Eq. (23.5) expansion becomes  $20 \log_{10} \sqrt{1} = 20 \log_{10} 1 = 0$  dB, which establishes the low-frequency asymptote.

The full idealized Bode response for the numerator of Eq. (23.45) is provided in Fig. 23.64.

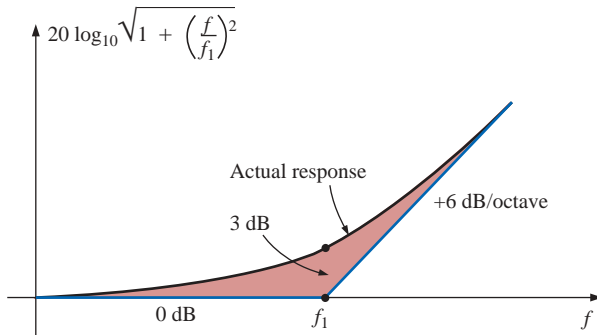

**FIG. 23.64**

*Idealized and actual Bode response for the magnitude of  $(1 + j(f/f_1))$ .*

We are now in a position to determine  $A_{v|dB}$  by plotting the asymptote for each function of Eq. (23.45) on the same frequency axis, as shown in Fig. 23.65. Note that  $f_c$  must be less than  $f_1$  since the denominator of  $f_1$  includes only  $R_2$ , whereas the denominator of  $f_c$  includes both  $R_2$  and  $R_1$ .

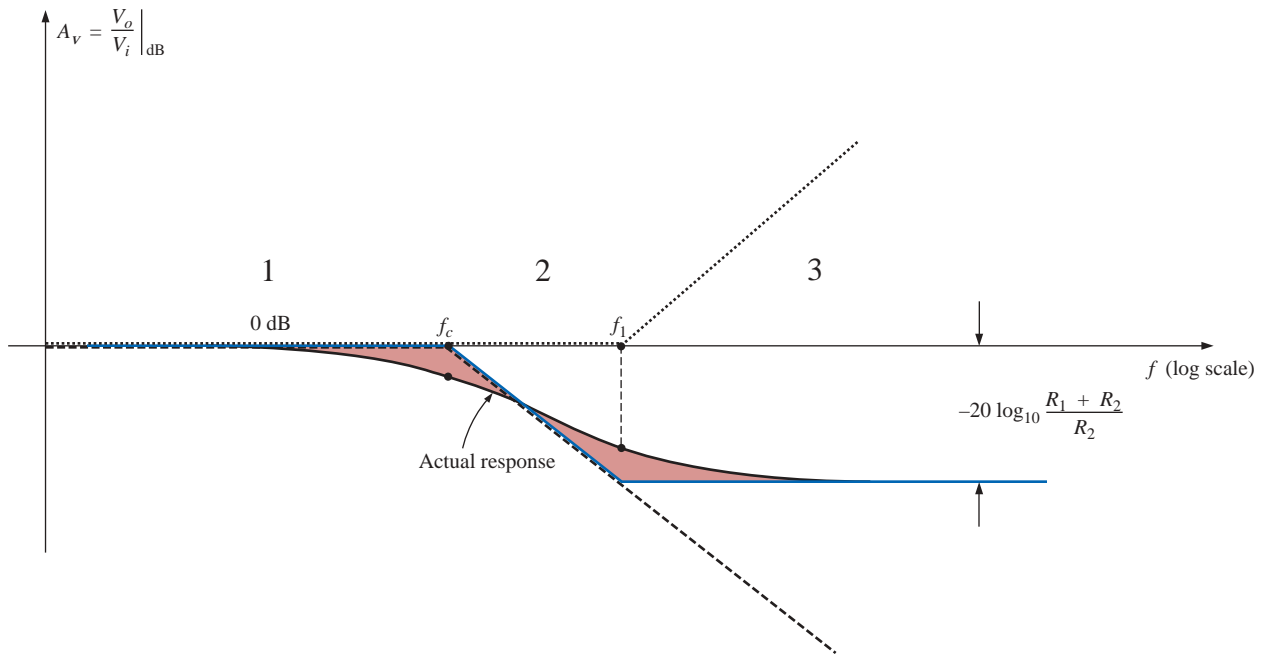

**FIG. 23.65**

*$A_{v|dB}$  versus frequency for the low-pass filter with limited attenuation of Fig. 23.62.*

Since  $R_2/(R_1 + R_2)$  will always be less than 1, we can use an earlier development to obtain an equation for the drop in dB below the 0-dB axis at high frequencies. That is,

$$\begin{aligned}
 20 \log_{10} R_2/(R_1 + R_2) &= 20 \log_{10} 1/((R_1 + R_2)/R_2) \\
 &= \underbrace{20 \log_{10} 1}_0 - 20 \log_{10}((R_1 + R_2)/R_2)
 \end{aligned}$$

and

$$20 \log_{10} \frac{R_2}{R_1 + R_2} = -20 \log_{10} \frac{R_1 + R_2}{R_2} \quad (23.46)$$

as shown in Fig. 23.65.

In region 1 of Fig. 23.65, both asymptotes are at 0 dB, resulting in a net Bode asymptote at 0 dB for the region. At  $f = f_c$ , one asymptote maintains its 0-dB level, whereas the other is dropping by 6 dB/octave. The sum of the two is the 6-dB drop per octave shown for the region. In region 3 the  $-6$ -dB/octave asymptote is balanced by the  $+6$ -dB/octave asymptote, establishing a level asymptote at the negative dB level attained by the  $f_c$  asymptote at  $f = f_1$ . The dB level of the horizontal asymptote in region 3 can be determined using Eq. (23.46) or by simply substituting  $f = f_1$  into the asymptotic expression defined by  $f_c$ .

The full idealized Bode envelope is now defined, permitting a sketch of the actual response by simply shifting 3 dB in the right direction at each corner frequency, as shown in Fig. 23.65.

The phase angle associated with  $\mathbf{A}_v$  can be determined directly from Eq. (23.45). That is,

$$\theta = \tan^{-1} f/f_1 - \tan^{-1} f/f_c \quad (23.47)$$

A full plot of  $\theta$  versus frequency can be obtained by simply substituting various key frequencies into Eq. (23.47) and plotting the result on a log scale.

The first term of Eq. (23.47) defines the phase angle established by the numerator of Eq. (23.45). The asymptotic plot established by the numerator is provided in Fig. 23.66. Note the phase angle of  $45^\circ$  at  $f = f_1$  and the straight-line asymptote between  $f_1/10$  and  $10f_1$ .

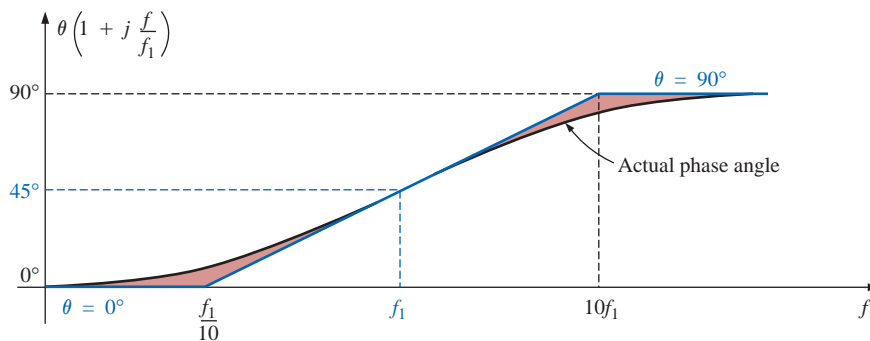
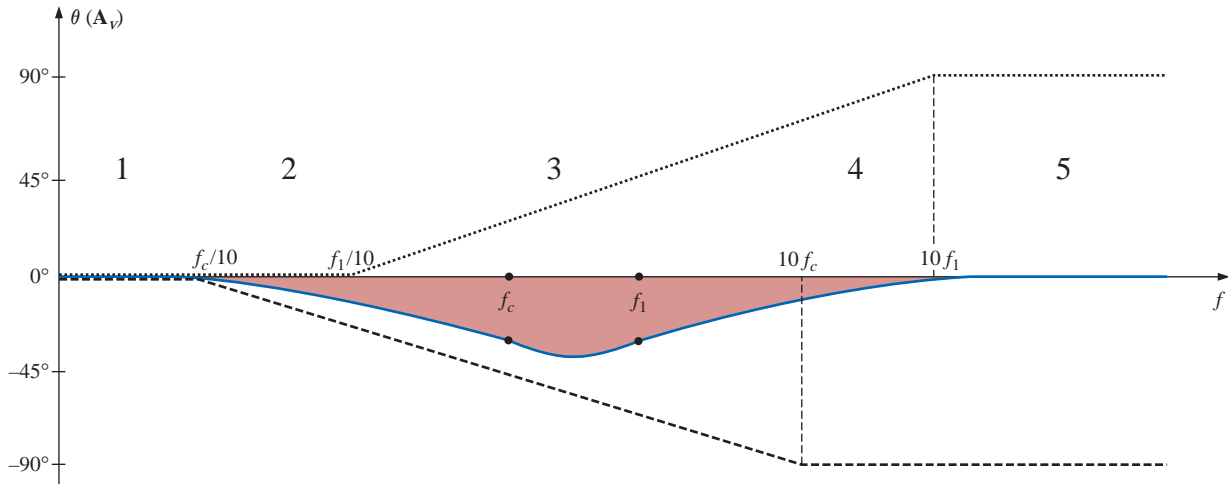

**FIG. 23.66**

Phase angle for  $(1 + j(f/f_1))$ .

Now that we have an asymptotic plot for the phase angle of the numerator, we can plot the full phase response by sketching the asymptotes for both functions of Eq. (23.45) on the same graph, as shown in Fig. 23.67.

The asymptotes of Fig. 23.67 clearly indicate that the phase angle will be  $0^\circ$  in the low-frequency range and  $0^\circ$  ( $90^\circ - 90^\circ = 0^\circ$ ) in the high-frequency range. In region 2 the phase plot drops below  $0^\circ$  due to the impact of the  $f_c$  asymptote. In region 4 the phase angle increases since the asymptote due to  $f_c$  remains fixed at  $-90^\circ$ , whereas that due to  $f_1$  is increasing. In the midrange the plot due to  $f_1$  is balancing the



**FIG. 23.67**  
Phase angle for the low-pass filter of Fig. 23.62.

continued negative drop due to the  $f_c$  asymptote, resulting in the leveling response indicated. Due to the equal and opposite slopes of the asymptotes in the midregion, the angles of  $f_1$  and  $f_c$  will be the same, but note that they are less than  $45^\circ$ . The maximum negative angle will occur between  $f_1$  and  $f_c$ . The remaining points on the curve of Fig. 23.67 can be determined by simply substituting specific frequencies into Eq. (23.45). However, it is also useful to know that the most dramatic (the quickest) changes in the phase angle occur when the dB plot of the magnitude also goes through its greatest changes (such as at  $f_1$  and  $f_c$ ).

### 23.13 HIGH-PASS FILTER WITH LIMITED ATTENUATION

The filter of Fig. 23.68 is designed to limit the low-frequency attenuation in much the same manner as described for the low-pass filter of the previous section.

At  $f = 0$  Hz the capacitor can assume its open-circuit equivalence, and  $V_o = [R_2/(R_1 + R_2)]V_i$ . At high frequencies the capacitor can be approximated by a short-circuit equivalence, and  $V_o = V_i$ .

The resistance to be employed when determining  $f_c$  can be found by finding the Thévenin resistance for the capacitor  $C$ , as shown in Fig. 23.69. A careful examination of the resulting configuration will reveal that  $R_{Th} = R_1 \parallel R_2$  and  $f_c = 1/2\pi(R_1 \parallel R_2)C$ .

A plot of  $V_o$  versus frequency is provided in Fig. 23.70(a), and a sketch of  $A_v = V_o/V_i$  appears in Fig. 23.70(b).

An equation for  $A_v = V_o/V_i$  can be derived by first applying the voltage divider rule:

$$V_o = \frac{R_2 V_i}{R_2 + R_1 \parallel -jX_C}$$

and  $A_v = \frac{V_o}{V_i} = \frac{R_2}{R_2 + R_1 \parallel -jX_C} = \frac{R_2}{R_2 + \frac{R_1(-jX_C)}{R_1 - jX_C}}$

$$= \frac{R_2(R_1 - jX_C)}{R_2(R_1 - jX_C) - jR_1X_C} = \frac{R_1R_2 - jR_2X_C}{R_1R_2 - jR_2X_C - jR_1X_C}$$

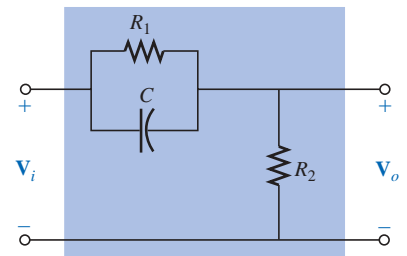

**FIG. 23.68**  
High-pass filter with limited attenuation.

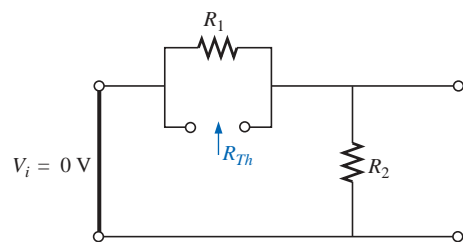

**FIG. 23.69**  
Determining  $R$  for the  $f_c$  calculation for the filter of Fig. 23.68.

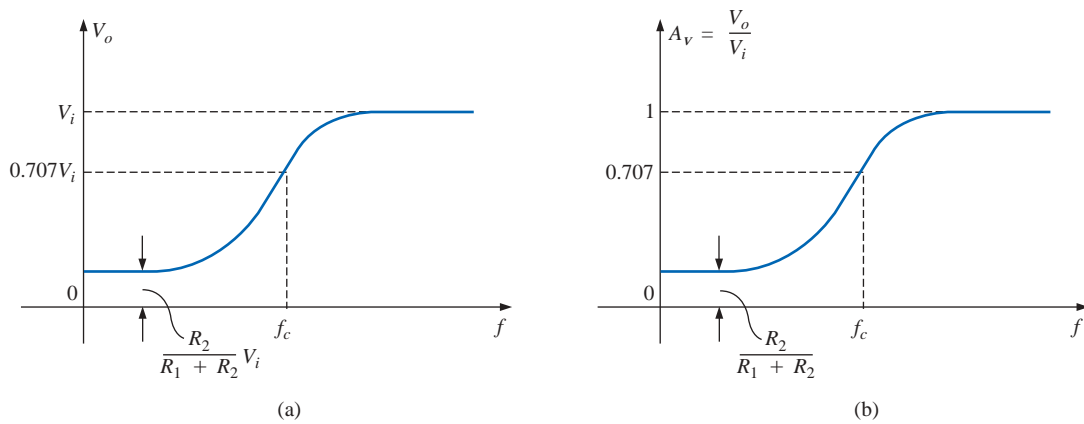

**FIG. 23.70**  
High-pass filter with limited attenuation.

$$\begin{aligned}
 &= \frac{R_1 R_2 - j R_2 X_C}{R_1 R_2 - j (R_1 + R_2) X_C} = \frac{1 - j \frac{R_2 X_C}{R_1 R_2}}{1 - j \frac{(R_1 + R_2) X_C}{R_1 R_2}} \\
 &= \frac{1 - j \frac{X_C}{R_1}}{1 - j \frac{X_C}{R_1 R_2}} = \frac{1 - j \frac{X_C}{R_1}}{1 - j \frac{X_C}{R_1 \parallel R_2}} = \frac{1 - j \frac{1}{2\pi f R_1 C}}{1 - j \frac{1}{2\pi f (R_1 \parallel R_2) C}}
 \end{aligned}$$

so that

$$\mathbf{A}_v = \frac{\mathbf{V}_o}{\mathbf{V}_i} = \frac{1 - j (f_1/f)}{1 - j (f_c/f)} \quad (23.48)$$

with  $f_1 = \frac{1}{2\pi R_1 C}$  and  $f_c = \frac{1}{2\pi (R_1 \parallel R_2) C}$

The denominator of Eq. (23.48) is simply the denominator of the high-pass function of Fig. 23.54(b). The numerator, however, is new and must be investigated.

Applying Eq. (23.5):

$$A_{v\text{dB}} = 20 \log_{10} \frac{V_o}{V_i} = 20 \log_{10} \sqrt{1 + (f_1/f)^2} + 20 \log_{10} \frac{1}{\sqrt{1 + (f_c/f)^2}}$$

For  $f \ll f_1$ ,  $(f_1/f)^2 \gg 1$ , and the first term becomes

$$20 \log_{10} \sqrt{(f_1/f)^2} = 20 \log_{10}(f_1/f) \Big|_{f \ll f_1}$$

which defines the idealized Bode asymptote for the numerator of Eq. (23.48).

$$\text{At } f = f_1, \quad 20 \log_{10} 1 = 0 \text{ dB}$$

$$\text{At } f = 0.5f_1, \quad 20 \log_{10} 2 = 6 \text{ dB}$$

$$\text{At } f = 0.1f_1, \quad 20 \log_{10} 10 = 20 \text{ dB}$$

For frequencies greater than  $f_1$ ,  $f_1/f \ll 1$  and  $20 \log_{10} 1 = 0$  dB, which establishes the high-frequency asymptote. The full idealized Bode plot for the numerator of Eq. (23.48) is provided in Fig. 23.71.

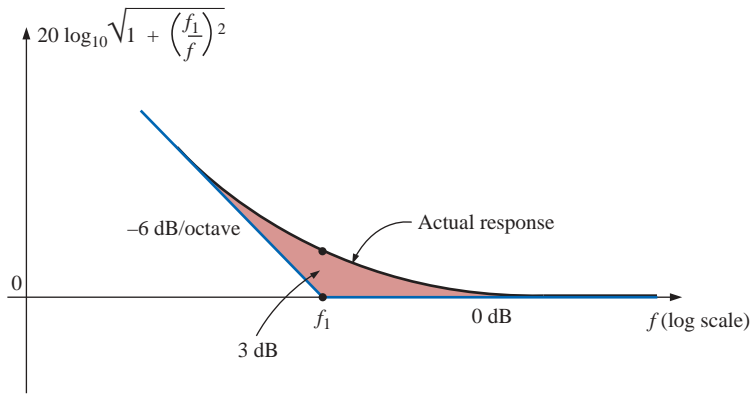
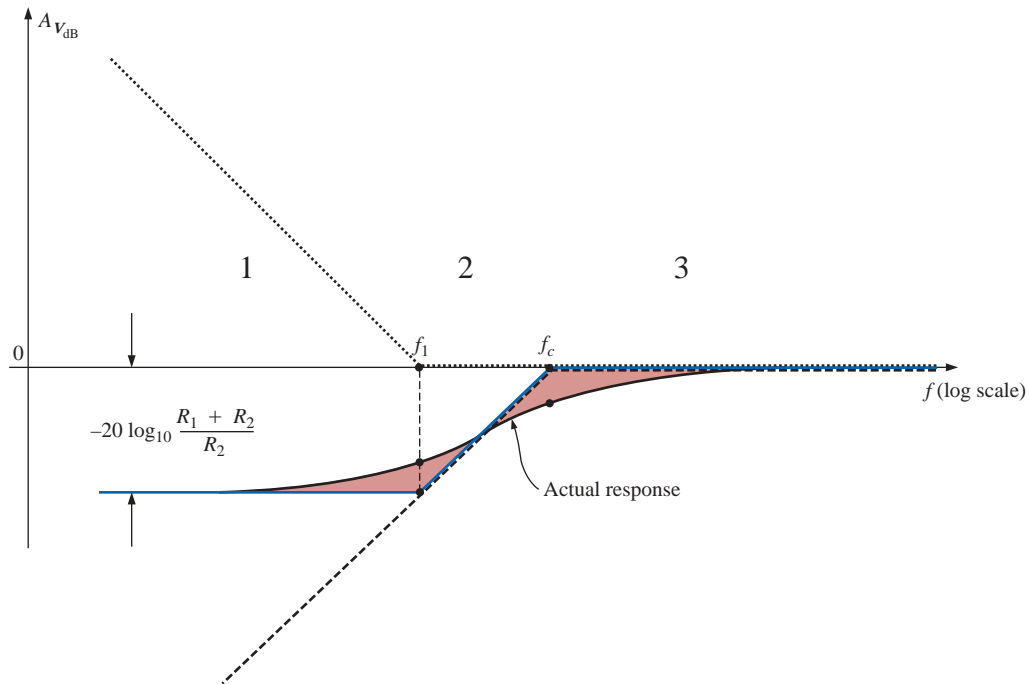

**FIG. 23.71**

*Idealized and actual Bode response for the magnitude of  $(1 - j(f_1/f))$ .*

We are now in a position to determine  $A_{v\text{dB}}$  by plotting the asymptotes for each function of Eq. (23.48) on the same frequency axis, as shown in Fig. 23.72. Note that  $f_c$  must be more than  $f_1$  since  $R_1 \parallel R_2$  must be less than  $R_1$ .

When determining the linearized Bode response, let us first examine region 2, where one function is 0 dB and the other is dropping at 6 dB/octave for decreasing frequencies. The result is a decreasing asymptote from  $f_c$  to  $f_1$ . At the intersection of the resultant of region 2 with  $f_1$ , we enter region 1, where the asymptotes have opposite slopes and cancel the effect of each other. The resulting level at  $f_1$  is determined by  $-20 \log_{10}(R_1 + R_2)/R_2$ , as found in earlier sections. The drop can also be determined by simply substituting  $f = f_1$  into the asymptotic equation defined for  $f_c$ . In region 3 both are at 0 dB, result-



**FIG. 23.72**

*$A_{v\text{dB}}$  versus frequency for the high-pass filter with limited attenuation of Fig. 23.68.*

ing in a 0-dB asymptote for the region. The resulting asymptotic and actual responses both appear in Fig. 23.72.

The phase angle associated with  $A_v$  can be determined directly from Eq. (23.48); that is,

$$\theta = -\tan^{-1} \frac{f_1}{f} + \tan^{-1} \frac{f_c}{f} \quad (23.49)$$

A full plot of  $\theta$  versus frequency can be obtained by simply substituting various key frequencies into Eq. (23.49) and plotting the result on a log scale.

The first term of Eq. (23.49) defines the phase angle established by the numerator of Eq. (23.48). The asymptotic plot resulting from the numerator is provided in Fig. 23.73. Note the leading phase angle of  $45^\circ$  at  $f = f_1$  and the straight-line asymptote from  $f_1/10$  to  $10f_1$ .

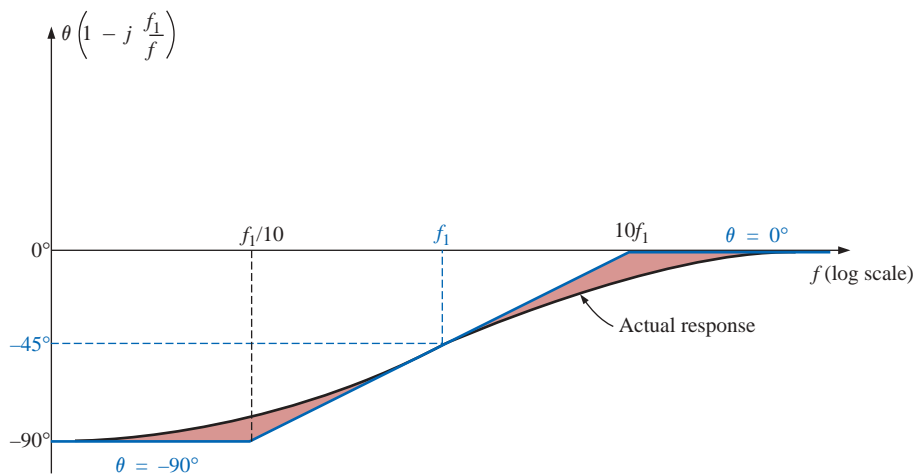

**FIG. 23.73**

Phase angle for  $(1 - j(f_1/f))$ .

Now that we have an asymptotic plot for the phase angle of the numerator, we can plot the full phase response by sketching the asymptotes for both functions of Eq. (23.48) on the same graph, as shown in Fig. 23.74.

The asymptotes of Fig. 23.74 clearly indicate that the phase angle will be  $90^\circ$  in the low-frequency range and  $0^\circ$  ( $90^\circ - 90^\circ = 0^\circ$ ) in the high-frequency range. In region 2 the phase angle is increasing above  $0^\circ$  because one angle is fixed at  $90^\circ$  and the other is becoming less negative. In region 4 one is  $0^\circ$  and the other is decreasing, resulting in a decreasing  $\theta$  for this region. In region 3 the positive angle is always greater than the negative angle, resulting in a positive angle for the entire region. Since the slopes of the asymptotes in region 3 are equal but opposite, the angles at  $f_c$  and  $f_1$  are the same. Figure 23.74 reveals that the angle at  $f_c$  and  $f_1$  will be less than  $45^\circ$ . The maximum angle will occur between  $f_c$  and  $f_1$ , as shown in the figure. Note again that the greatest change in  $\theta$  occurs at the corner frequencies, matching the regions of greatest change in the dB plot.

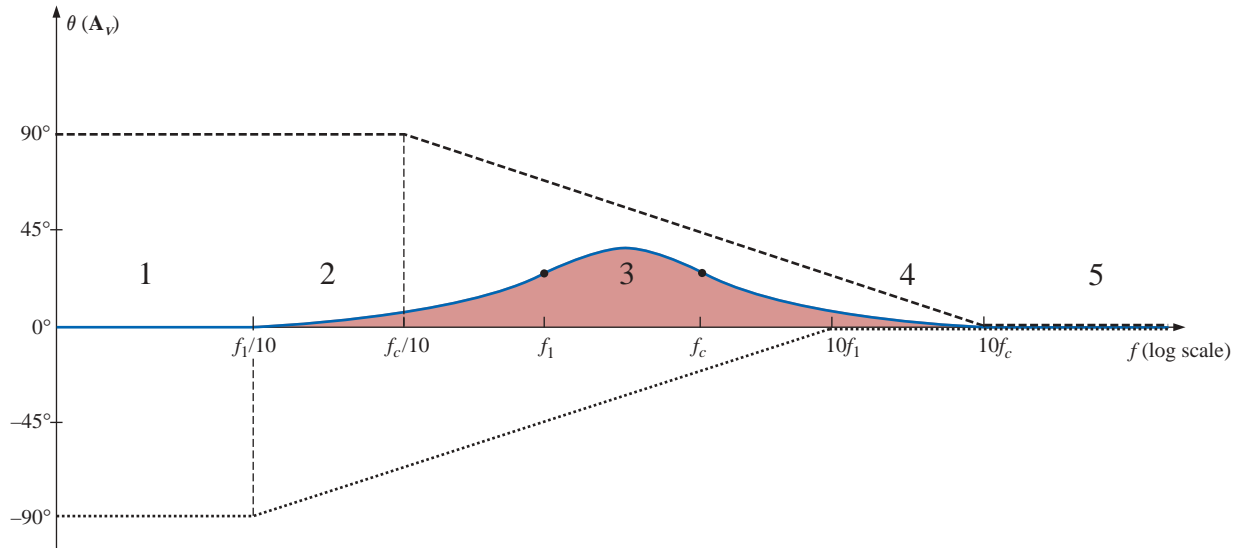

FIG. 23.74

Phase response for the high-pass filter of Fig. 23.68.

**EXAMPLE 23.11** For the filter of Fig. 23.75:

- Sketch the curve of  $A_{v\text{dB}}$  versus frequency using a log scale.
- Sketch the curve of  $\theta$  versus frequency using a log scale.

**Solutions:**

- For the break frequencies:

$$f_1 = \frac{1}{2\pi R_1 C} = \frac{1}{2\pi(9.1 \text{ k}\Omega)(0.47 \text{ }\mu\text{F})} = \mathbf{37.2 \text{ Hz}}$$

$$f_c = \frac{1}{2\pi \left( \frac{R_1 R_2}{R_1 + R_2} \right) C} = \frac{1}{2\pi(0.9 \text{ k}\Omega)(0.47 \text{ }\mu\text{F})} = \mathbf{376.25 \text{ Hz}}$$

The maximum low-level attenuation is

$$\begin{aligned} -20 \log_{10} \frac{R_1 + R_2}{R_2} &= -20 \log_{10} \frac{9.1 \text{ k}\Omega + 1 \text{ k}\Omega}{1 \text{ k}\Omega} \\ &= -20 \log_{10} 10.1 = \mathbf{-20.09 \text{ dB}} \end{aligned}$$

The resulting plot appears in Fig. 23.76.

- For the break frequencies:

At  $f = f_1 = 37.2 \text{ Hz}$ ,

$$\begin{aligned} \theta &= -\tan^{-1} \frac{f_1}{f} + \tan^{-1} \frac{f_c}{f} \\ &= -\tan^{-1} 1 + \tan^{-1} \frac{376.25 \text{ Hz}}{37.2 \text{ Hz}} \\ &= -45^\circ + 84.35^\circ \\ &= \mathbf{39.35^\circ} \end{aligned}$$

At  $f = f_c = 376.26 \text{ Hz}$ ,

$$\theta = -\tan^{-1} \frac{37.2 \text{ Hz}}{376.26 \text{ Hz}} + \tan^{-1} 1$$

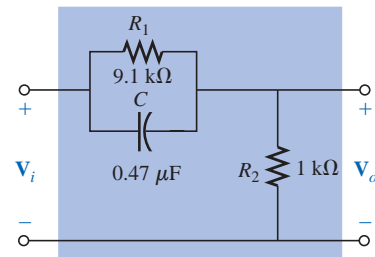

FIG. 23.75

Example 23.11.

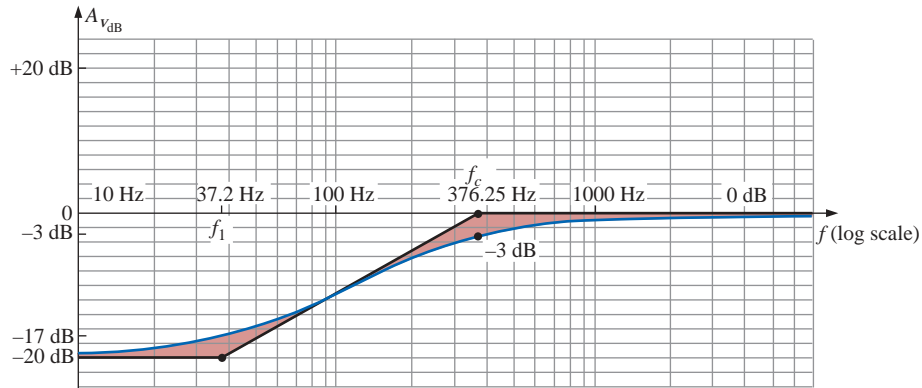

FIG. 23.76

$A_{v_{dB}}$  versus frequency for the filter of Fig. 23.75.

$$\begin{aligned} &= -5.65^\circ + 45^\circ \\ &= \mathbf{39.35^\circ} \end{aligned}$$

At a frequency midway between  $f_c$  and  $f_1$  on a log scale, for example, 120 Hz:

$$\begin{aligned} \theta &= -\tan^{-1} \frac{37.2 \text{ Hz}}{120 \text{ Hz}} + \tan^{-1} \frac{376.26 \text{ Hz}}{120 \text{ Hz}} \\ &= -17.22^\circ + 72.31^\circ \\ &= \mathbf{55.09^\circ} \end{aligned}$$

The resulting phase plot appears in Fig. 23.77.

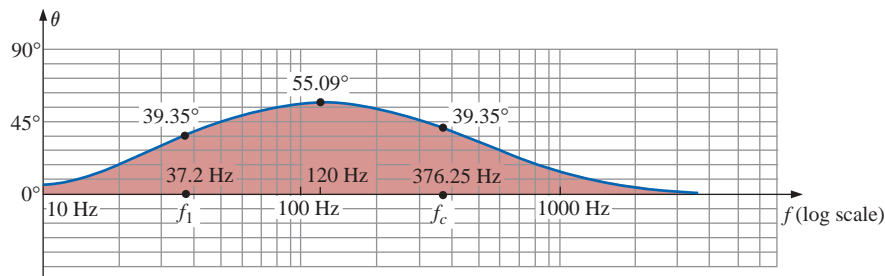

FIG. 23.77

$\theta$  (the phase angle associated with  $A_v$ ) versus frequency for the filter of Fig. 23.75.

## 23.14 OTHER PROPERTIES AND A SUMMARY TABLE

Bode plots are not limited to filters but can be applied to any system for which a dB-versus-frequency plot is desired. Although the previous sections did not cover all the functions that lend themselves to the idealized linear asymptotes, many of those most commonly encountered have been introduced.

We now examine some of the special situations that can develop that will further demonstrate the adaptability and usefulness of the linear Bode approach to frequency analysis.

In all the situations described in this chapter, there was only one term in the numerator or denominator. For situations where there is more than one term, there will be an interaction between functions that must be examined and understood. In many cases the use of Eq. (23.5) will prove useful. For example, if  $\mathbf{A}_v$  should have the format

$$\mathbf{A}_v = \frac{200(1 - jf_2/f)(jf/f_1)}{(1 - jf_1/f)(1 + jf/f_2)} = \frac{(a)(b)(c)}{(d)(e)} \quad (23.50)$$

we can expand the function in the following manner:

$$\begin{aligned} A_{v_{\text{dB}}} &= 20 \log_{10} \frac{(a)(b)(c)}{(d)(e)} \\ &= 20 \log_{10} a + 20 \log_{10} b + 20 \log_{10} c - 20 \log_{10} d - 20 \log_{10} e \end{aligned}$$

revealing that the net or resultant dB level is equal to the algebraic sum of the contributions from all the terms of the original function. We will, therefore, be able to add algebraically the linearized Bode plots of all the terms in each frequency interval to determine the idealized Bode plot for the full function.

If two terms happen to have the same format and corner frequency, as in the function

$$\mathbf{A}_v = \frac{1}{(1 - jf_1/f)(1 - jf_1/f)}$$

the function can be rewritten as

$$\mathbf{A}_v = \frac{1}{(1 - jf_1/f)^2}$$

so that

$$\begin{aligned} A_{v_{\text{dB}}} &= 20 \log_{10} \frac{1}{(\sqrt{1 + (f_1/f)^2})^2} \\ &= -20 \log_{10}(1 + (f_1/f)^2) \end{aligned}$$

for  $f \ll f_1$ ,  $(f_1/f)^2 \gg 1$ , and

$$A_{v_{\text{dB}}} = -20 \log_{10}(f_1/f)^2 = -40 \log_{10} f_1/f$$

versus the  $-20 \log_{10}(f_1/f)$  obtained for a single term in the denominator. The resulting dB asymptote will drop, therefore, at a rate of  $-12$  dB/octave ( $-40$  dB/decade) for decreasing frequencies rather than  $-6$  dB/octave. The corner frequency is the same, and the high-frequency asymptote is still at 0 dB. The idealized Bode plot for the above function is provided in Fig. 23.78.

Note the steeper slope of the asymptote and the fact that the actual curve will now pass  $-6$  dB below the corner frequency rather than  $-3$  dB, as for a single term.

Keep in mind that if the corner frequencies of the two terms in the numerator or denominator are close but not exactly equal, the total dB drop is the algebraic sum of the contributing terms of the expansion. For instance, consider the linearized Bode plot of Fig. 23.79 with corner frequencies  $f_1$  and  $f_2$ .

In region 3 both asymptotes are 0 dB, resulting in an asymptote at 0 dB for frequencies greater than  $f_2$ . For region 2, one asymptote is at 0 dB, whereas the other drops at  $-6$  dB/octave for decreasing frequencies. The net result for this region is an asymptote dropping at  $-6$  dB, as shown in the same figure. At  $f_1$ , we find two asymptotes dropping off at  $-6$  dB for decreasing frequencies. The result is an asymptote dropping off at  $-12$  dB/octave for this region.

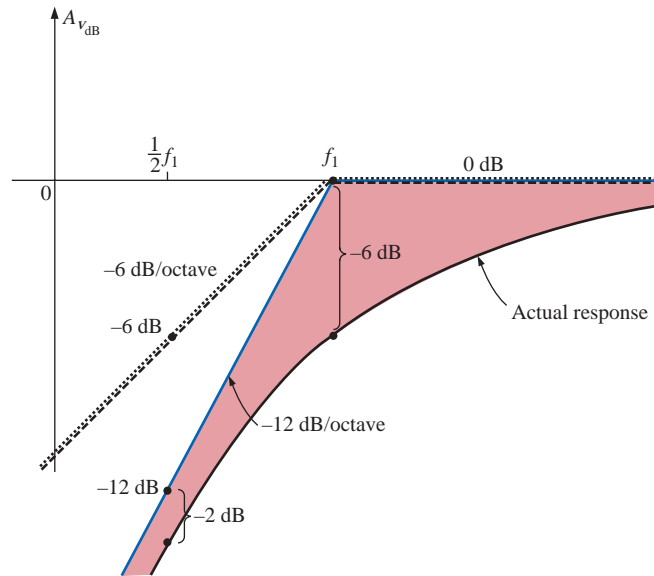

**FIG. 23.78**  
Plotting the linearized Bode plot of  $\frac{1}{(1 - j(f_1/f))^2}$ .

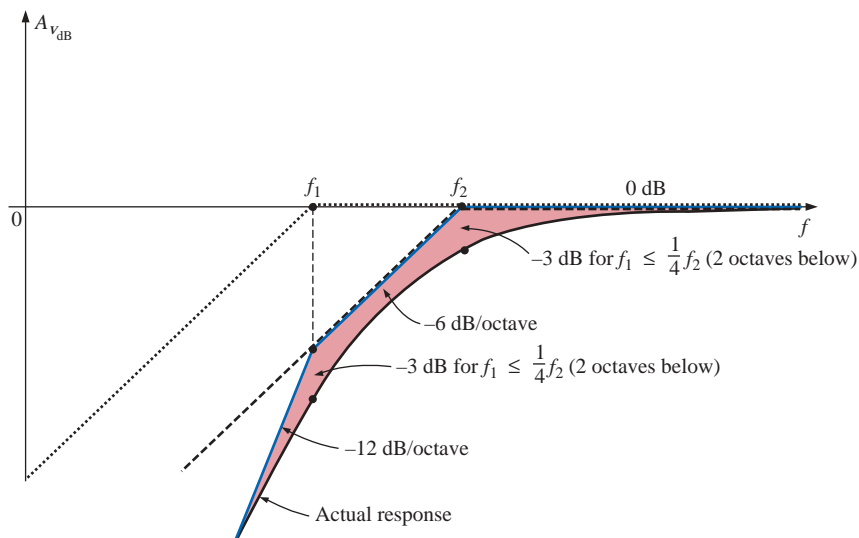

**FIG. 23.79**  
Plot of  $A_{v_{dB}}$  for  $\frac{1}{(1 - j(f_1/f))(1 - j(f_2/f))}$  with  $f_1 < f_2$ .

If  $f_1$  and  $f_2$  are at least two octaves apart, the effect of one on the plotting of the actual response for the other can just about be ignored. In other words, for this example, if  $f_1 < \frac{1}{4}f_2$ , then the actual response will be down  $-3$  dB at  $f = f_2$  and  $f_1$ .

The above discussion can be expanded for any number of terms at the same frequency or in the same region. For three equal terms in the denominator, the asymptote will drop at  $-18$  dB/octave, and so on. In time the procedure will be somewhat self-evident and relatively straightforward to apply. In many cases the hardest part of finding a solution is to put the original function in the desired form.

**EXAMPLE 23.12** A transistor amplifier has the following gain:

$$A_v = \frac{100}{\left(1 - j \frac{50 \text{ Hz}}{f}\right) \left(1 - j \frac{200 \text{ Hz}}{f}\right) \left(1 + j \frac{f}{10 \text{ kHz}}\right) \left(1 + j \frac{f}{20 \text{ kHz}}\right)}$$

- Sketch the normalized response  $A'_v = A_v/A_{v_{\max}}$ , and determine the bandwidth of the amplifier.
- Sketch the phase response, and determine a frequency where the phase angle is close to  $0^\circ$ .

**Solutions:**

$$\begin{aligned} \text{a. } A'_v &= \frac{A_v}{A_{v_{\max}}} = \frac{A_v}{100} \\ &= \frac{1}{\left(1 - j \frac{50 \text{ Hz}}{f}\right) \left(1 - j \frac{200 \text{ Hz}}{f}\right) \left(1 + j \frac{f}{10 \text{ kHz}}\right) \left(1 + j \frac{f}{20 \text{ kHz}}\right)} \\ &= \frac{1}{(a)(b)(c)(d)} = \left(\frac{1}{a}\right) \left(\frac{1}{b}\right) \left(\frac{1}{c}\right) \left(\frac{1}{d}\right) \end{aligned}$$

and

$$A'_{v_{\text{dB}}} = -20 \log_{10} a - 20 \log_{10} b - 20 \log_{10} c - 20 \log_{10} d$$

clearly substantiating the fact that the total number of decibels is equal to the algebraic sum of the contributing terms.

A careful examination of the original function will reveal that the first two terms in the denominator are high-pass filter functions, whereas the last two are low-pass functions. Figure 23.80 demonstrates how the combination of the two types of functions defines a bandwidth for the amplifier. The high-frequency filter functions have defined the low cutoff frequency, and the low-frequency filter functions have defined the high cutoff frequency.

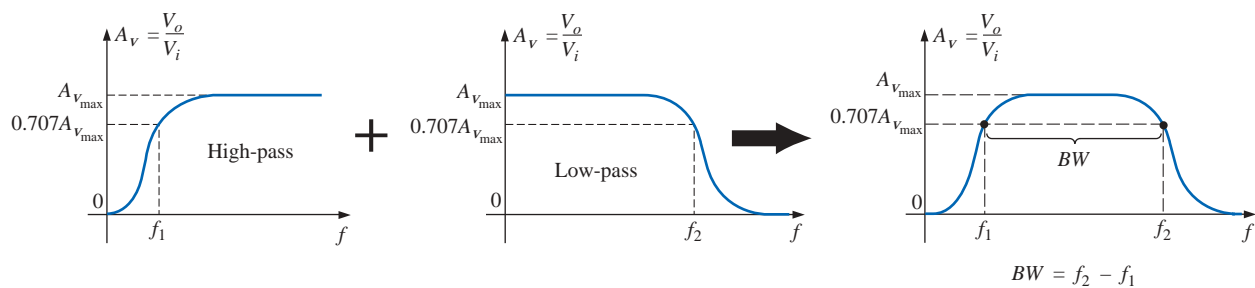

**FIG. 23.80**

*Finding the overall gain versus frequency for Example 23.12.*

Plotting all the idealized Bode plots on the same axis will result in the plot of Fig. 23.81. Note for frequencies less than 50 Hz that the resulting asymptote drops off at  $-12$  dB/octave. In addition, since 50 Hz and 200 Hz are separated by two octaves, the actual response will be down by only about  $-3$  dB at the corner frequencies of 50 Hz and 200 Hz.

For the high-frequency region, the corner frequencies are not separated by two octaves, and the difference between the idealized plot

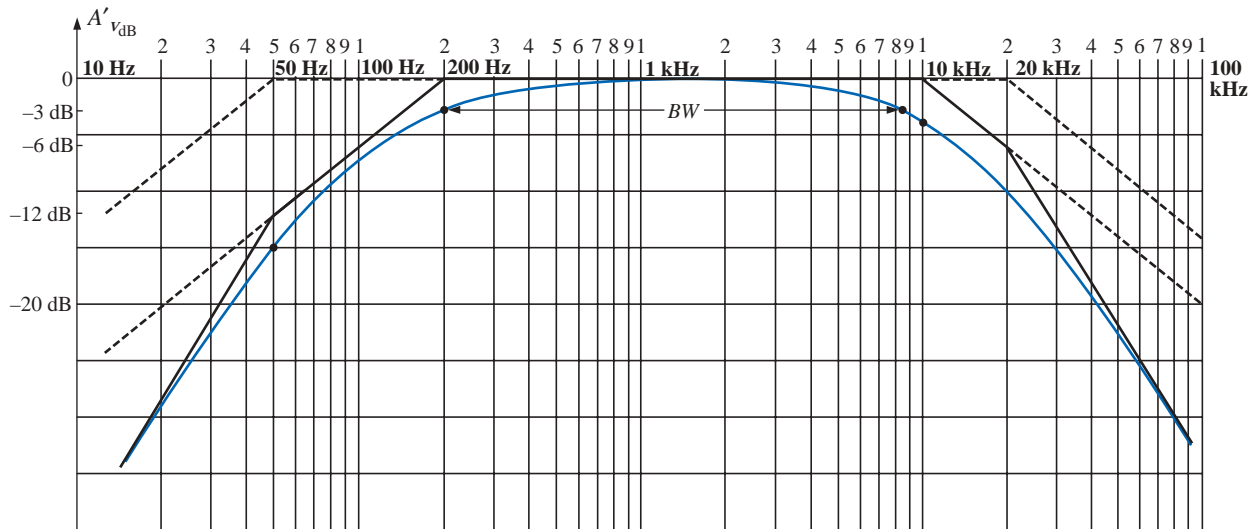

FIG. 23.81

$A'_{v_{dB}}$  versus frequency for Example 23.12.

and the actual Bode response must be examined more carefully. Since 10 kHz is one octave below 20 kHz, we can use the fact that the difference between the idealized response and the actual response for a single corner frequency is 1 dB. If we add an additional  $-1$ -dB drop due to the 20-kHz corner frequency to the  $-3$ -dB drop at  $f = 10$  kHz, we can conclude that the drop at 10 kHz will be  $-4$  dB, as shown on the plot. To check the conclusion, let us write the full expression for the dB level at 10 kHz and find the actual level for comparison purposes.

$$\begin{aligned} A'_{v_{dB}} &= -20 \log_{10} \sqrt{1 + \left(\frac{50 \text{ Hz}}{10 \text{ kHz}}\right)^2} - 20 \log_{10} \sqrt{1 + \left(\frac{200 \text{ Hz}}{10 \text{ kHz}}\right)^2} \\ &\quad - 20 \log_{10} \sqrt{1 + \left(\frac{10 \text{ kHz}}{10 \text{ kHz}}\right)^2} - 20 \log_{10} \sqrt{1 + \left(\frac{10 \text{ kHz}}{20 \text{ kHz}}\right)^2} \\ &= -0.00011 \text{ dB} - 0.0017 \text{ dB} - 3.01 \text{ dB} - 0.969 \text{ dB} \\ &= -3.98 \text{ dB} \cong \mathbf{-4 \text{ dB}} \quad \text{as before} \end{aligned}$$

An examination of the above calculations clearly reveals that the last two terms predominate in the high-frequency region and essentially eliminate the need to consider the first two terms in that region. For the low-frequency region an examination of the first two terms is sufficient.

Proceeding in a similar fashion, we find a  $-4$ -dB difference at  $f = 20$  kHz, resulting in the actual response appearing in Fig. 23.81. Since the bandwidth is defined at the  $-3$ -dB level, a judgment must be made as to where the actual response crosses the  $-3$ -dB level in the high-frequency region. A rough sketch suggests that it is near 8.5 kHz. Plugging this frequency into the high-frequency terms results in

$$\begin{aligned} A'_{v_{dB}} &= -20 \log_{10} \sqrt{1 + \left(\frac{8.5 \text{ kHz}}{10 \text{ kHz}}\right)^2} - 20 \log_{10} \sqrt{1 + \left(\frac{8.5 \text{ kHz}}{20 \text{ kHz}}\right)^2} \\ &= -2.148 \text{ dB} - 0.645 \text{ dB} \cong \mathbf{-2.8 \text{ dB}} \end{aligned}$$

which is relatively close to the  $-3$ -dB level, and

$$BW = f_{\text{high}} - f_{\text{low}} = 8.5 \text{ kHz} - 200 \text{ Hz} = \mathbf{8.3 \text{ kHz}}$$

In the midrange of the bandwidth,  $A'_{\text{vdB}}$  will approach 0 dB. At  $f = 1 \text{ kHz}$ :

$$\begin{aligned} A'_{\text{vdB}} &= -20 \log_{10} \sqrt{1 + \left(\frac{50 \text{ Hz}}{1 \text{ kHz}}\right)^2} - 20 \log_{10} \sqrt{1 + \left(\frac{200 \text{ Hz}}{1 \text{ kHz}}\right)^2} \\ &\quad - 20 \log_{10} \sqrt{1 + \left(\frac{1 \text{ kHz}}{10 \text{ kHz}}\right)^2} - 20 \log_{10} \sqrt{1 + \left(\frac{1 \text{ kHz}}{20 \text{ kHz}}\right)^2} \\ &= -0.0108 \text{ dB} - 0.1703 \text{ dB} - 0.0432 \text{ dB} - 0.0108 \text{ dB} \\ &= \mathbf{-0.2351 \text{ dB} \cong -\frac{1}{5} \text{ dB}} \end{aligned}$$

which is certainly close to the 0-dB level, as shown on the plot.

- b. The phase response can be determined by simply substituting a number of key frequencies into the following equation, derived directly from the original function  $A_v$ :

$$\theta = \tan^{-1} \frac{50 \text{ Hz}}{f} + \tan^{-1} \frac{200 \text{ Hz}}{f} - \tan^{-1} \frac{f}{10 \text{ kHz}} - \tan^{-1} \frac{f}{20 \text{ kHz}}$$

However, let us make full use of the asymptotes defined by each term of  $A_v$  and sketch the response by finding the resulting phase angle at critical points on the frequency axis. The resulting asymptotes and phase plot are provided in Fig. 23.82. Note that at  $f = 50 \text{ Hz}$ , the sum of the two angles determined by the straight-line asymptotes is  $45^\circ + 75^\circ = 120^\circ$  (actual =  $121^\circ$ ). At  $f = 1 \text{ kHz}$ , if we subtract  $5.7^\circ$  for one corner frequency, we obtain a net angle of  $14^\circ - 5.7^\circ \cong 8.3^\circ$  (actual =  $5.6^\circ$ ).

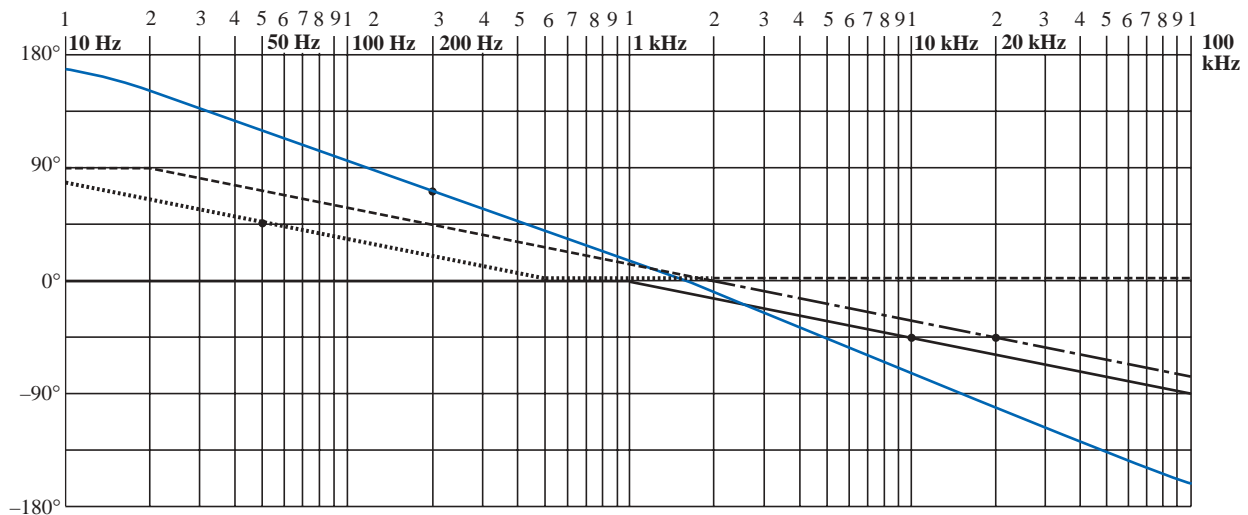

FIG. 23.82

Phase response for Example 23.12.

At 10 kHz the asymptotes leave us with  $\theta \cong -45^\circ - 32^\circ = -77^\circ$  (actual =  $-71.56^\circ$ ). The net phase plot appears to be close to  $0^\circ$  at about 1300 Hz. As a check on our assumptions and the use of the asymptotic approach, let us plug in  $f = 1300 \text{ Hz}$  into the equation for  $\theta$ :

$$\begin{aligned}
 \theta &= \tan^{-1} \frac{50 \text{ Hz}}{1300 \text{ Hz}} + \tan^{-1} \frac{200 \text{ Hz}}{1300 \text{ Hz}} - \tan^{-1} \frac{1300 \text{ Hz}}{10 \text{ kHz}} - \tan^{-1} \frac{1300 \text{ Hz}}{20 \text{ kHz}} \\
 &= 2.2^\circ + 8.75^\circ - 7.41^\circ - 3.72^\circ \\
 &= -0.18^\circ \cong 0^\circ \quad \text{as predicted}
 \end{aligned}$$

In total, the phase plot appears to shift from a positive angle of  $180^\circ$  ( $\mathbf{V}_o$  leading  $\mathbf{V}_i$ ) to a negative angle of  $180^\circ$  as the frequency spectrum extends from very low frequencies to high frequencies. In the midregion the phase plot is close to  $0^\circ$  ( $\mathbf{V}_o$  in phase with  $\mathbf{V}_i$ ), much like the response to a common-base transistor amplifier.

In an effort to consolidate some of the material introduced in this chapter and provide a reference for future investigations, Table 23.2 was developed; it includes the linearized dB and phase plots for the functions appearing in the first column. These are by no means all the functions encountered, but they do provide a foundation to which additional functions can be added.

Reviewing the development of the filters of Sections 23.12 and 23.13, it is probably evident that establishing the function  $\mathbf{A}_v$  in the proper form is the most difficult part of the analysis. However, with practice and an awareness of the desired format, methods will surface that will significantly reduce the effort involved.

### 23.15 CROSSOVER NETWORKS

The topic of *crossover networks* is included primarily to present an excellent demonstration of filter operation without a high level of complexity. Crossover networks are employed in audio systems to ensure that the proper frequencies are channeled to the appropriate speaker. Although less expensive audio systems have to rely on one speaker to cover the full audio range from about 20 Hz to 20 kHz, better systems will employ at least three speakers to cover the low range (20 Hz to about 500 Hz), the midrange (500 Hz to about 5 kHz), and the high range (5 kHz and up). The term *crossover* comes from the fact that the system is designed to have a crossover of frequency spectrums for adjacent speakers at the  $-3$ -dB level, as shown in Fig. 23.83. Depending on the design, each filter can drop off at 6 dB, 12 dB, or 18 dB, with complexity increasing with the desired dB drop-off rate. The three-way crossover network of Fig. 23.83 is quite simple in design, with a low-pass  $R$ - $L$  filter for the *woofer*, an  $R$ - $L$ - $C$  pass-band filter for the midrange, and a high-pass  $R$ - $C$  filter for the *tweeter*. The basic equations for the components are provided below. Note the similarity between the equations, with the only difference for each type of element being the cutoff frequency.

$$L_{\text{low}} = \frac{R}{2\pi f_1} \quad L_{\text{mid}} = \frac{R}{2\pi f_2} \quad (23.51)$$

$$C_{\text{mid}} = \frac{1}{2\pi f_1 R} \quad C_{\text{high}} = \frac{1}{2\pi f_2 R} \quad (23.52)$$

**TABLE 23.2**  
Idealized Bode plots for various functions.

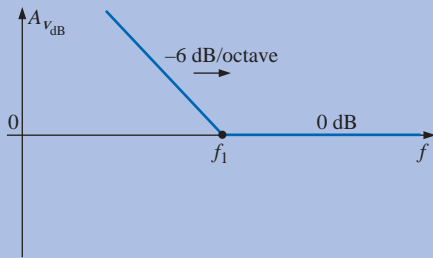
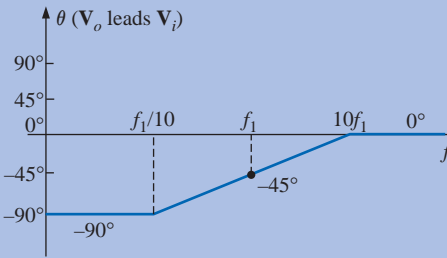
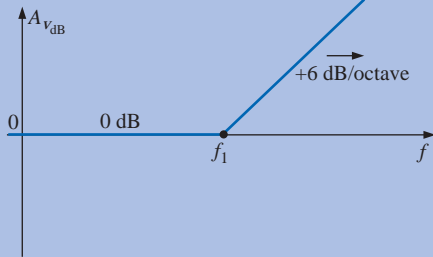
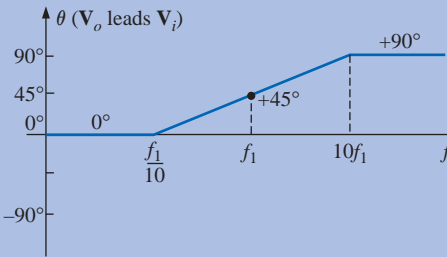
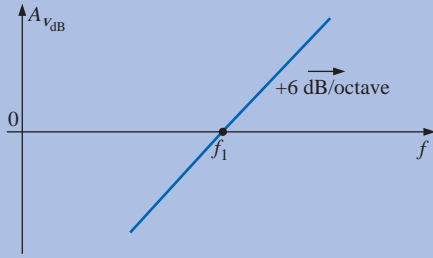
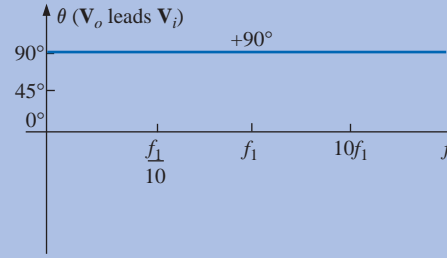
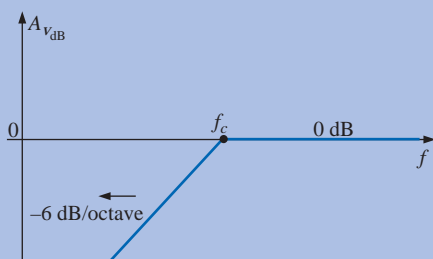
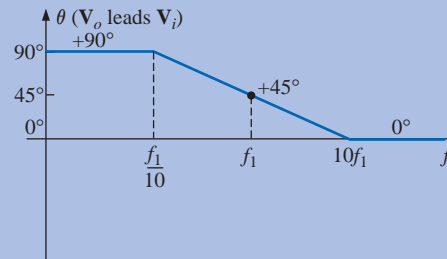
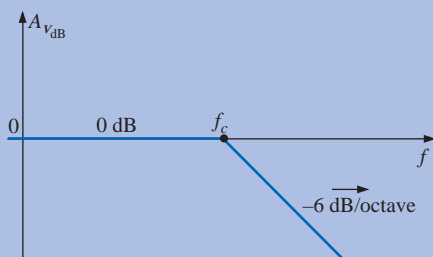
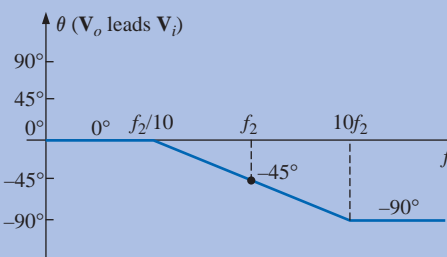
| Function                                      | dB Plot   | Phase Plot   |
|---|---|--|
| $\mathbf{A}_v = 1 - j\frac{f_1}{f}$           |    |    |
| $\mathbf{A}_v = 1 + j\frac{f}{f_1}$           |    |    |
| $\mathbf{A}_v = j\frac{f}{f_1}$               |   |   |
| $\mathbf{A}_v = \frac{1}{1 - j\frac{f}{f_c}}$ |  |  |
| $\mathbf{A}_v = \frac{1}{1 + j\frac{f}{f_c}}$ |  |  |

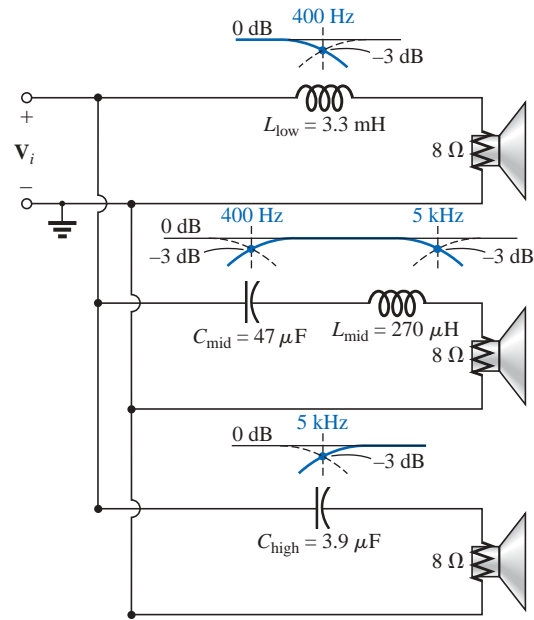

FIG. 23.83

Three-way, 6-dB-per-octave, crossover network.

For the crossover network of Fig. 23.83 with three 8- $\Omega$  speakers, the resulting values are

$$L_{\text{low}} = \frac{R}{2\pi f_1} = \frac{8 \Omega}{2\pi(400 \text{ Hz})} = 3.183 \text{ mH} \rightarrow 3.3 \text{ mH} \quad (\text{commercial value})$$

$$L_{\text{mid}} = \frac{R}{2\pi f_2} = \frac{8 \Omega}{2\pi(5 \text{ kHz})} = 254.65 \mu\text{H} \rightarrow 270 \mu\text{H} \quad (\text{commercial value})$$

$$C_{\text{mid}} = \frac{1}{2\pi f_1 R} = \frac{1}{2\pi(400 \text{ Hz})(8 \Omega)} = 49.736 \mu\text{F} \rightarrow 47 \mu\text{F} \quad (\text{commercial value})$$

$$C_{\text{high}} = \frac{1}{2\pi f_2 R} = \frac{1}{2\pi(5 \text{ kHz})(8 \Omega)} = 3.979 \mu\text{F} \rightarrow 3.9 \mu\text{F} \quad (\text{commercial value})$$

as appearing on Fig. 23.83.

For each filter, a rough sketch of the frequency response is included to show the crossover at the specific frequencies of interest. Because all three speakers are in parallel, the source voltage and impedance for each are the same. The total loading on the source is obviously a function of the frequency applied, but the total delivered is determined solely by the speakers since they are essentially resistive in nature.

To test the system, let us apply a 4-V signal at a frequency of 1 kHz (a predominant frequency of the typical human auditory response curve) and see which speaker will have the highest power level.

At  $f = 1 \text{ kHz}$ ,

$$X_{L_{\text{low}}} = 2\pi f L_{\text{low}} = 2\pi(1 \text{ kHz})(3.3 \text{ mH}) = 20.74 \Omega$$

$$\begin{aligned} \mathbf{V}_o &= \frac{(\mathbf{Z}_R \angle 0^\circ)(\mathbf{V}_i \angle 0^\circ)}{\mathbf{Z}_T} = \frac{(8 \Omega \angle 0^\circ)(4 \text{ V} \angle 0^\circ)}{8 \Omega + j 20.74 \Omega} \\ &= 1.44 \text{ V} \angle -68.90^\circ \end{aligned}$$

$$X_{L_{\text{mid}}} = 2\pi f L_{\text{mid}} = 2\pi(1 \text{ kHz})(270 \mu\text{H}) = 1.696 \Omega$$

$$X_{C_{\text{mid}}} = \frac{1}{2\pi f C_{\text{mid}}} = \frac{1}{2\pi(1 \text{ kHz})(47 \mu\text{F})} = 3.386 \Omega$$

$$\mathbf{V}_o = \frac{(\mathbf{Z}_R \angle 0^\circ)(\mathbf{V}_i \angle 0^\circ)}{\mathbf{Z}_T} = \frac{(8 \Omega \angle 0^\circ)(4 \text{ V} \angle 0^\circ)}{8 \Omega + j 1.696 \Omega - j 3.386 \Omega}$$

$$= 3.94 \text{ V} \angle 11.93^\circ$$

$$X_{C_{\text{high}}} = \frac{1}{2\pi f C_{\text{high}}} = \frac{1}{2\pi(1 \text{ kHz})(3.9 \mu\text{F})} = 40.81 \Omega$$

$$\mathbf{V}_o = \frac{(\mathbf{Z}_R \angle 0^\circ)(\mathbf{V}_i \angle 0^\circ)}{\mathbf{Z}_T} = \frac{(8 \Omega \angle 0^\circ)(4 \text{ V} \angle 0^\circ)}{8 \Omega - j 40.81 \Omega}$$

$$= 0.77 \text{ V} \angle 78.91^\circ$$

Using the basic power equation  $P = V^2/R$ , the power to the woofer is

$$P_{\text{low}} = \frac{V^2}{R} = \frac{(1.44 \text{ V})^2}{8 \Omega} = \mathbf{0.259 \text{ W}}$$

to the midrange speaker,

$$P_{\text{mid}} = \frac{V^2}{R} = \frac{(3.94 \text{ V})^2}{8 \Omega} = \mathbf{1.94 \text{ W}}$$

and to the tweeter,

$$P_{\text{high}} = \frac{V^2}{R} = \frac{(0.77 \text{ V})^2}{8 \Omega} = \mathbf{0.074 \text{ W}}$$

resulting in a power ratio of 7.5:1 between the midrange and the woofer and 26:1 between the midrange and the tweeter. Obviously, the response of the midrange speaker will totally overshadow the other two.

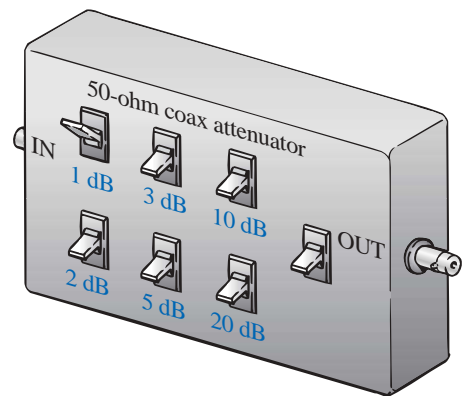

FIG. 23.84  
Passive coax attenuator.

## 23.16 APPLICATIONS

### Attenuators

Attenuators are, by definition, any device or system that can reduce the power or voltage level of a signal while introducing little or no distortion. There are two general types: passive and active. The passive type uses only resistors, while the active type uses electronic devices such as transistors and integrated circuits. Since electronics is a subject for the courses to follow, our attention here will be only on the resistive type. Attenuators are commonly used in audio equipment (such as the graphic and parametric equalizers introduced in the previous chapter), antenna systems, AM or FM systems where attenuation may be required before the signals are mixed, and any other application where a reduction in signal strength is required.

The unit of Fig. 23.84 has coaxial input and output terminals and switches to set the level of dB reduction. It has a flat response from dc to about 6 GHz, which essentially means that its introduction into the network will not affect the frequency response for this band of frequencies. The design is rather simple with resistors connected in either a tee (T) or a wye (Y) configuration as shown in Figs. 23.85 and 23.86, respectively, for a 50-Ω coaxial system. In each case the resistors are

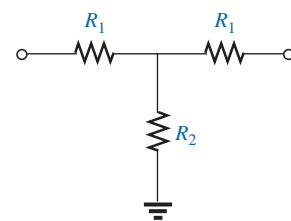

| Attenuation | $R_1$  | $R_2$   |
|-------------|--------|---------|
| 1 dB        | 2.9 Ω  | 433.3 Ω |
| 2 dB        | 5.7 Ω  | 215.2 Ω |
| 3 dB        | 8.5 Ω  | 141.9 Ω |
| 5 dB        | 14.0 Ω | 82.2 Ω  |
| 10 dB       | 26.0 Ω | 35.0 Ω  |
| 20 dB       | 41.0 Ω | 10.0 Ω  |

FIG. 23.85  
Tee (T) configuration.

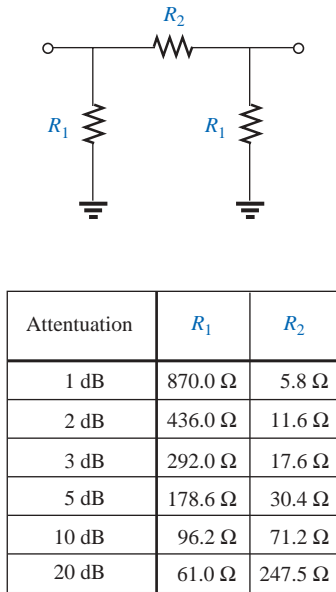

**FIG. 23.86**  
Wye (Y) configuration.

chosen to ensure that the input impedance and output impedance match the line. That is, the input and output impedances of each configuration will be 50  $\Omega$ . For a number of dB attenuations, the resistor values for the T and Y are provided in Figs. 23.85 and 23.86. Note in each design that two of the resistors are the same, while the third is a much smaller or larger value.

For the 1-dB attenuation, the resistor values were inserted for the T configuration in Fig. 23.87(a). Terminating the configuration with a 50- $\Omega$  load, we find through the following calculations that the input impedance is, in fact, 50  $\Omega$ :

$$\begin{aligned}
 R_i &= R_1 + R_2 \parallel (R_1 + R_L) = 2.9 \Omega + 433.3 \Omega \parallel (2.9 \Omega + 50 \Omega) \\
 &= 2.9 \Omega + 47.14 \Omega \\
 &= \mathbf{50.04 \Omega}
 \end{aligned}$$

Looking back from the load as shown in Fig. 23.87(b) with the source set to zero volts, we find through the following calculations that the output impedance is also 50  $\Omega$ :

$$\begin{aligned}
 R_o &= R_1 + R_2 \parallel (R_1 + R_s) = 2.9 \Omega + 433.3 \Omega \parallel (2.9 \Omega + 50 \Omega) \\
 &= 2.9 \Omega + 47.14 \Omega \\
 &= \mathbf{50.04 \Omega}
 \end{aligned}$$

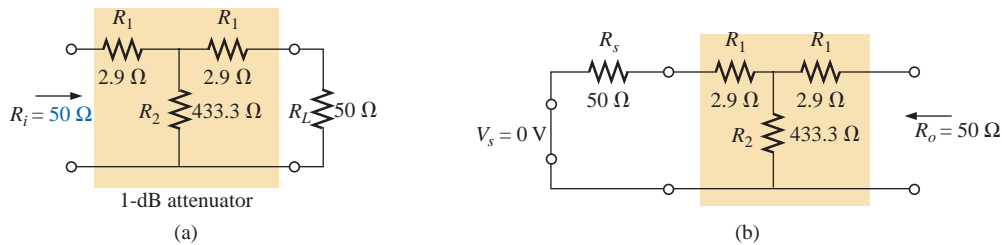

**FIG. 23.87**  
1-dB attenuator: (a) loaded; (b) finding  $R_o$ .

In Fig. 23.88, a 50- $\Omega$  load has been applied, and the output voltage is determined as follows:

$$\begin{aligned}
 R' &= R_2 \parallel (R_1 + R_L) = 47.14 \Omega \quad \text{from above} \\
 \text{and} \quad V_{R_2} &= \frac{R' V_s}{R' + R_1} = \frac{47.14 \Omega V_s}{47.14 \Omega + 2.9 \Omega} = 0.942 V_s \\
 \text{with} \quad V_L &= \frac{R_L V_{R_2}}{R_L + R_1} = \frac{50 \Omega (0.942 V_s)}{50 \Omega + 2.9 \Omega} = 0.890 V_s
 \end{aligned}$$

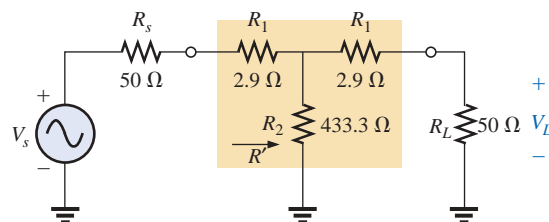

**FIG. 23.88**  
Determining the voltage levels for the 1-dB attenuator of Fig. 23.87(a).

Calculating the drop in dB will result in the following:

$$\begin{aligned}
 A_{v\text{dB}} &= 20 \log_{10} \frac{V_L}{V_s} = 20 \log_{10} \frac{0.890V_s}{V_s} \\
 &= 20 \log_{10} 0.890 = -1.01 \text{ dB}
 \end{aligned}$$

substantiating the fact that there is a 1-dB attenuation.

As mentioned earlier, there are other methods for attenuation that are more sophisticated in design and beyond the scope of the coverage of this text. However, the above designs are quite effective and relatively inexpensive, and they perform the task at hand quite well.

### Noise Filters

Noise is a problem that can occur in any electronic system. In general, it is the presence of any unwanted signal that can affect the overall operation of a system. It can come from a power source (60-Hz hum), from feedback networks, from mechanical systems connected to electrical systems, from stray capacitive and inductive effects, or possibly from a local signal source that is not properly shielded—the list is endless. The manner in which the noise is eliminated or handled is normally analyzed by someone with a broad practical background and with a sense for the origin for the unwanted noise and how to remove it in the simplest and most direct way. In most cases the problem will not be part of the original design but a second effort in the testing phase to remove unexpected problems. Although sophisticated methods can be applied when the problem can be serious in nature, most situations are handled simply by the proper placement of an element or two of a value sensitive to the problem.

In Fig. 23.89 two capacitors have been strategically placed in the tape recording and playback sections of a tape recorder to remove the

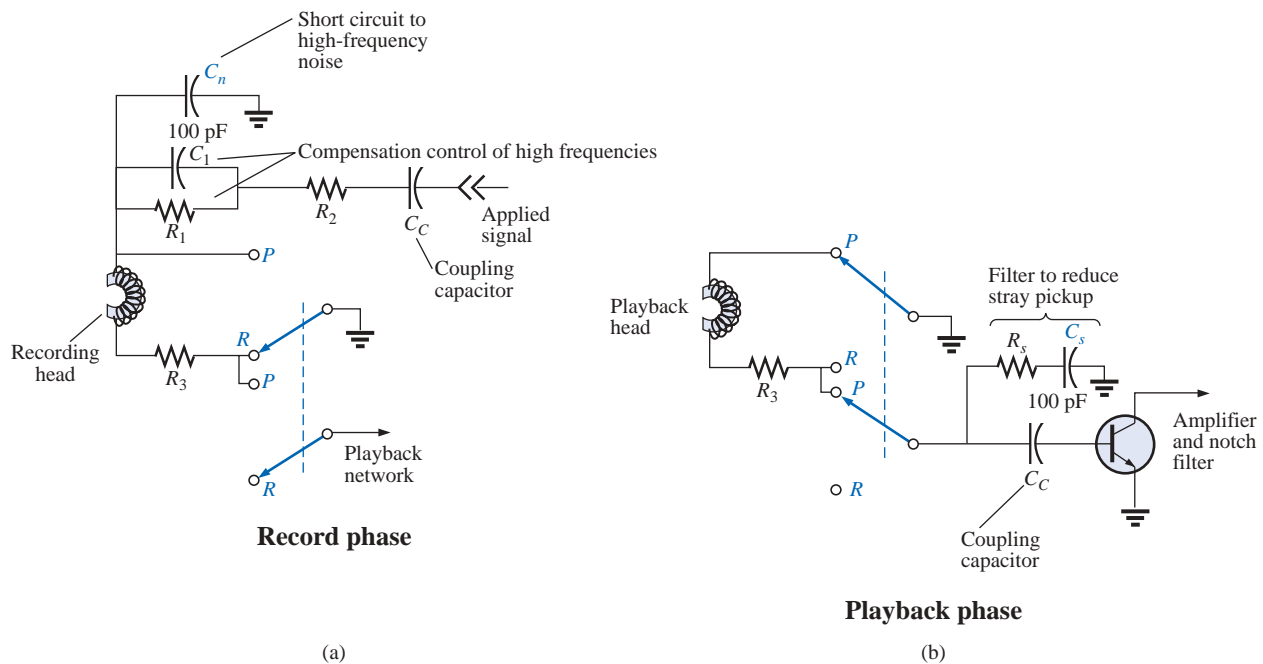
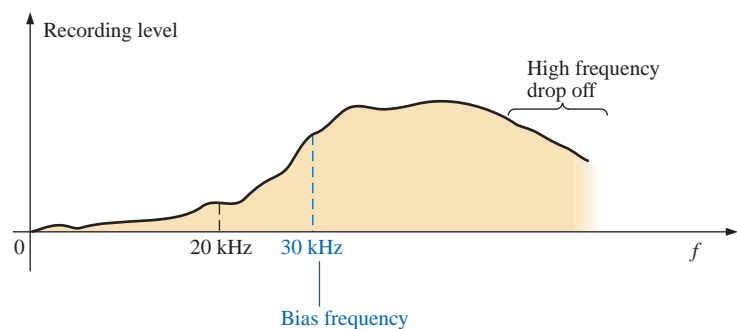

FIG. 23.89

Noise reduction in a tape recorder.

undesirable high-frequency noise (rushing sound) that can result from unexpected, randomly placed particles on a magnetic tape, noise coming down the line, or noise introduced from the local environment. During the record mode, with the switches in the positions shown (*R*), the 100-pF capacitor at the top of the schematic will act as a short circuit to the high-frequency noise. The capacitor  $C_1$  is included to compensate for the fact that recording on a tape is not a linear process versus frequency. In other words, certain frequencies are recorded at higher amplitudes than others.

In Fig. 23.90 a sketch of recording level versus frequency has been provided, clearly indicating that the human audio range of about 40 Hz to 20 kHz is very poor for the tape recording process, starting to rise only after 20 kHz. Thus, tape recorders must include a fixed biasing frequency which when added to the actual audio signal will bring the frequency range to be amplified to the region of high-amplitude recording. On some tapes the *actual bias frequency* is provided, while on others the phrase *normal bias* is used. Even after you pass the bias frequency, there is a frequency range that follows that drops off considerably. Compensation for this drop-off is provided by the parallel combination of the resistor  $R_1$  and the capacitor  $C_1$  mentioned above. At frequencies near the bias frequency, the capacitor is designed to act essentially like an open circuit (high reactance), and the head current and voltage are limited by the resistors  $R_1$  and  $R_2$ . At frequencies in the region where the tape gain drops off with frequency, the capacitor begins to take on a lower reactance level and reduce the net impedance across the parallel branch of  $R_1$  and  $C_1$ . The result is an increase in head current and voltage due to the lower net impedance in the line, resulting in a leveling in the tape gain following the bias frequency. Eventually, the capacitor will begin to take on the characteristics of a short circuit, effectively shorting out the resistance  $R_1$ , and the head current and voltage will be a maximum. During playback this bias frequency is eliminated by a notch filter so that the original sound is not distorted by the high-frequency signal.

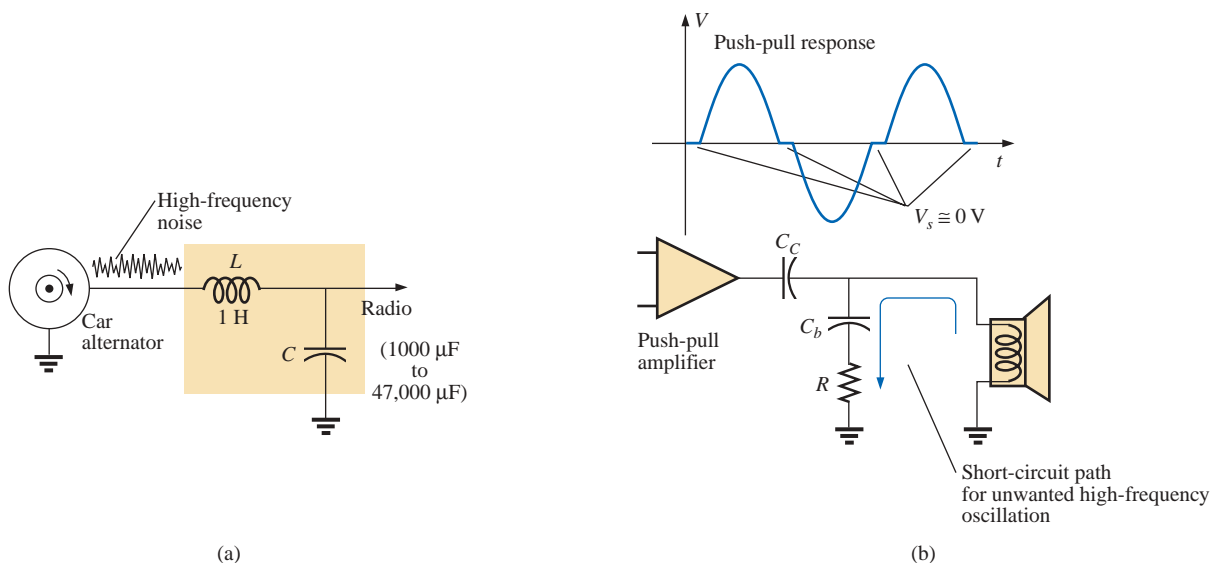

**FIG. 23.90**

*Noise reduction in a tape recorder.*

During playback (*P*), the upper circuit of Fig. 23.89 is set to ground by the upper switch, and the lower network comes into play. Again note the second 100-pF capacitor connected to the base of the transistor to short to ground any undesirable high-frequency noise. The resistor is there to absorb any power associated with the noise signal when the capacitor takes on its short-circuit equivalence. Keep in mind that the capacitor was chosen to act as a short-circuit equivalent for a particular frequency range and not for the audio range where it is essentially an open circuit.

Alternators in a car are notorious for developing high-frequency noise down the line to the radio, as shown in Fig. 23.91(a). This problem is usually alleviated by placing a high-frequency filter in the line as shown. The inductor of 1 H will offer a high impedance for the range of noise frequencies, while the capacitor (1000  $\mu\text{F}$  to 47,000  $\mu\text{F}$ ) will act as a short-circuit equivalent to any noise that happens to get through. For the speaker system in Fig. 23.91(b), the push-pull power arrangement of transistors in the output section can often develop a short period of time between pulses where the strong signal voltage is zero volts. During this short period the coil of the speaker rears its inductive effects, sees an unexpected path to ground like a switch opening, and quickly cuts off the speaker current. Through the familiar relationship  $v_L = L(di_L/dt)$ , an unexpected voltage will develop across the coil and set a high-frequency oscillation on the line that will find its way back to the amplifier and cause further distortion. This effect can be subdued by placing an  $R$ - $C$  path to ground that will offer a low-resistance path from the speaker to ground for a range of frequencies typically generated by this signal distortion. Since the capacitor will assume a short-circuit equivalence for the range of noise disturbance, the resistor was added to limit the current and absorb the energy associated with the signal noise.



**FIG. 23.91**

*Noise generation: (a) due to a car alternator; (b) from a push-pull amplifier.*

In regulators, such as the 5-V regulator of Fig. 23.92(a), when a spike in current comes down the line for any number of reasons, there will be a voltage drop along the line, and the input voltage to the regulator will drop. The regulator, performing its primary function, will sense this drop in input voltage and will increase its amplification level through a feedback loop to maintain a constant output. However, the spike is of such short duration that the output voltage will have a spike of its own because the input voltage has quickly returned to its normal level, and with the increased amplification the output will jump to a higher level. Then the regulator senses its error and quickly cuts its gain. The sensitivity to changes in the input level has caused the output level to go through a number of quick oscillations that can be a real

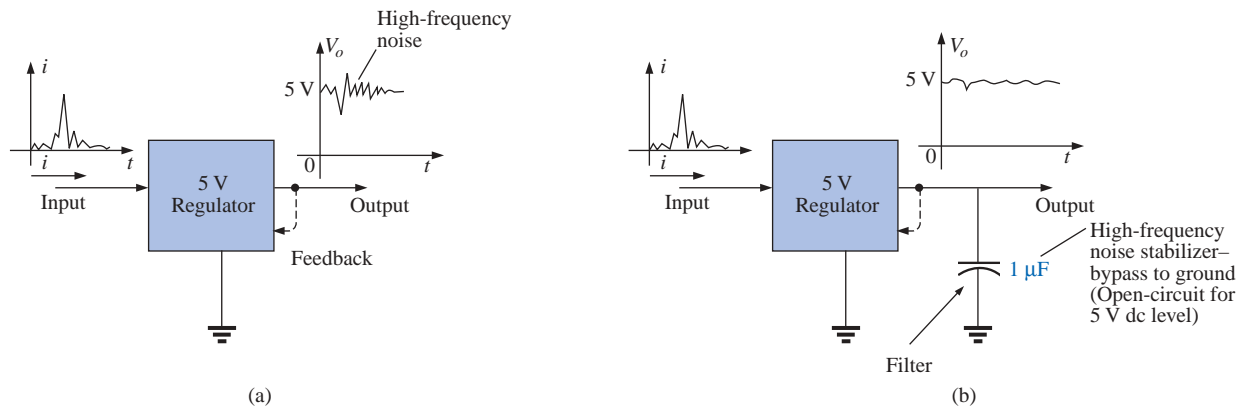

FIG. 23.92

Regulator: (a) effect of spike in current on the input side; (b) noise reduction.

problem for the equipment to which the dc voltage is applied: A high-frequency noise signal has been developed. One way to subdue this reaction and, in fact, slow the system response down so that very short interval spikes have less impact is to add a capacitor across the output as shown in Fig. 23.92(b). Since the regulator is providing a fixed dc level, a large capacitor of  $1\ \mu\text{F}$  can be used to short-circuit a wide range of high-frequency disturbances. However, you don't want to make the capacitor too large or you'll get too much *damping*, and large overshoots and undershoots can develop. To maximize the input of the added capacitor, you must place it physically closer to the regulator and to avoid developing any delay time between output signal and capacitive reaction.

In general, as you examine the schematic of working systems and see elements that don't appear to be part of any standard design procedure, you can assume that they are either protective devices or due to noise on the line that is affecting the operation of the system. Noting their type, value, and location will often reveal their purpose and modus operandi.

## 23.17 COMPUTER ANALYSIS

### PSpice

**High-Pass Filter** The computer analysis will begin with an investigation of the high-pass filter of Fig. 23.93. The cutoff frequency is determined by  $f_c = 1/2\pi RC = 1.592\ \text{kHz}$ , with the voltage across the resistor approaching  $1\ \text{V}$  at high frequencies at a phase angle of  $0^\circ$ .

For this analysis, the ac voltage source **VAC** was used. Within the **Property Editor**, the quantities defined appear next to the source in Fig. 23.93. Otherwise, building the circuit is quite straightforward.

Our interest lies in the effect of frequency on the magnitude of the output voltage across the resistor and the resulting phase angle. Following the selection of **AC Sweep** under the **Analysis type** heading, the **Start Frequency** should be set at  $10\ \text{Hz}$  so that we have some data points at the very low end and an **End Frequency** of  $100\ \text{kHz}$  so that we extend well into the high frequencies. Here is the obvious advantage

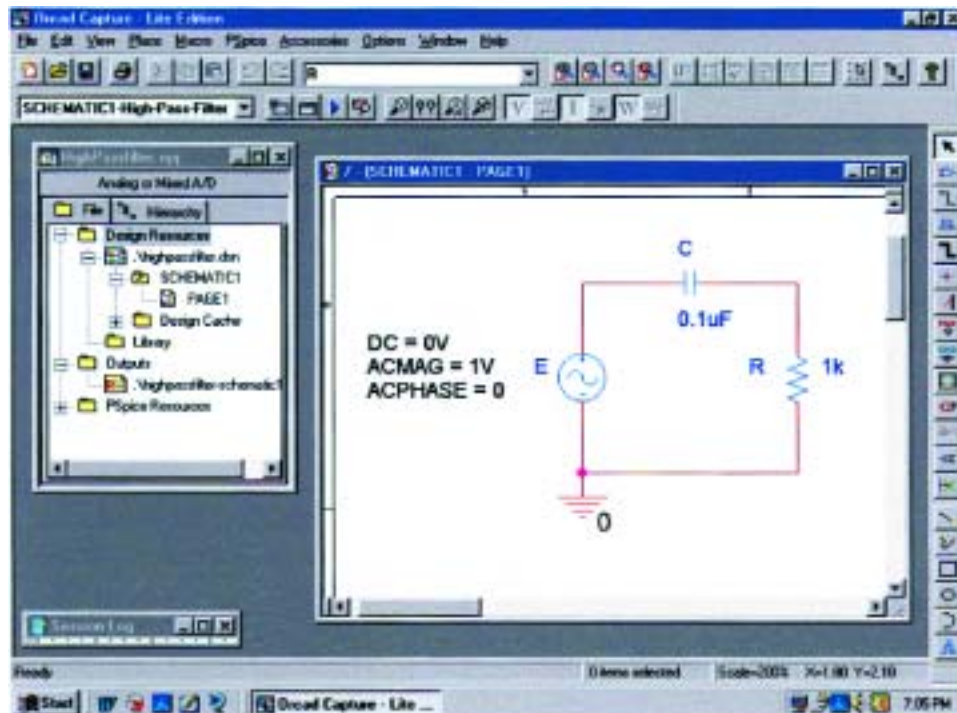

FIG. 23.93

*High-pass R-C filter to be investigated using PSpice.*

of the logarithmic axis: a wide range of values on a plot of limited size. To ensure sufficient data points, the **Points/Decade** was set at 10k. When **V(R:1)** is selected, the resulting **SCHEMATIC1** appears as shown in Fig. 23.94. Note the nice transition from one region to the other. At low frequencies when the reactance of the capacitor far outweighs that of the resistor, most of the applied voltage appears across the capacitor, and very little across the resistor. At much higher frequencies the reactance of the capacitor drops off very quickly, and the voltage across the resistor picks up toward a maximum of 1 V.

Select **Plot-Add Plot to Window-Trace-Add Trace-P(V(R:1))-OK**, and the phase plot of Fig.23.94 results showing a shift from  $90^\circ$ , when the network is highly capacitive in nature, to  $0^\circ$ , when it becomes resistive. If we select the phase plot **SEL>>** and click on the **Toggle cursor** pad, a left click will place a cursor on the screen that can define the frequency at which the phase angle is  $45^\circ$ . At  $45.12^\circ$ , which is the closest we can come with the available data points, we find that the corresponding frequency is 1.585 kHz which is a very close match with the 1.592 kHz calculated above. The right-click cursor can be placed at 100 kHz to show that the phase angle has dropped to  $0.91^\circ$ , which certainly defines the network as resistive at this frequency.

**Double-Tuned Filter** Our analysis will now turn to a fairly complex-looking filter for which an enormous amount of time would be required to generate a detailed plot of gain versus frequency using a handheld calculator. It is the same filter examined in Example 23.9, so we have a chance to test our theoretical solution. The schematic appears in Fig. 23.95 with **VAC** again chosen since the frequency range of interest will be set by the **Simulation Profile**. Again, the attributes for the source

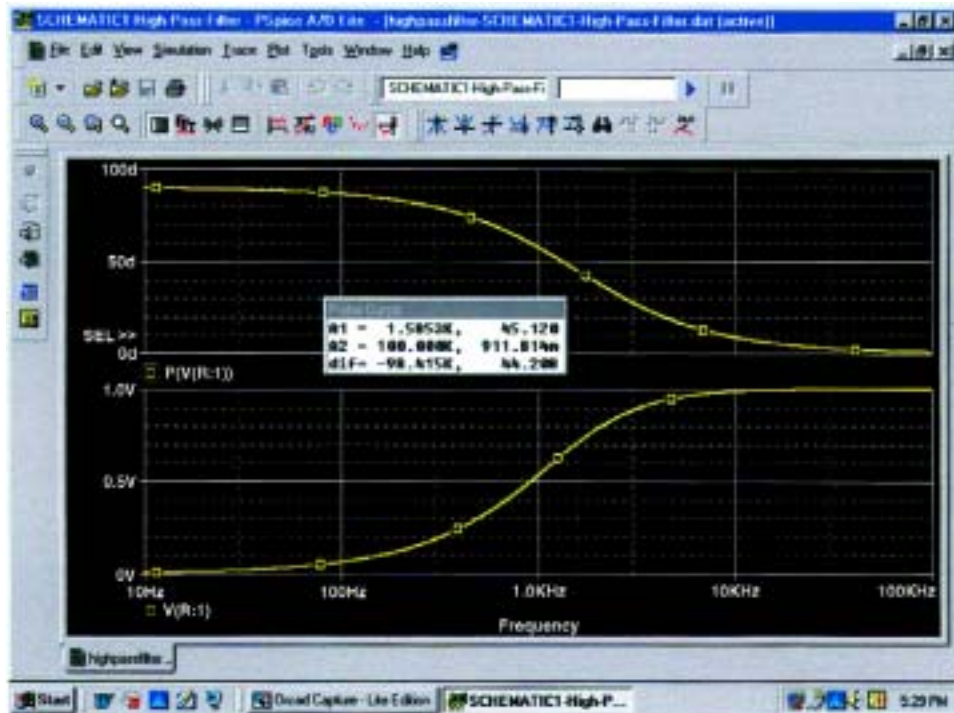

FIG. 23.94

Magnitude and phase plot for the high-pass R-C filter of Fig. 23.93.

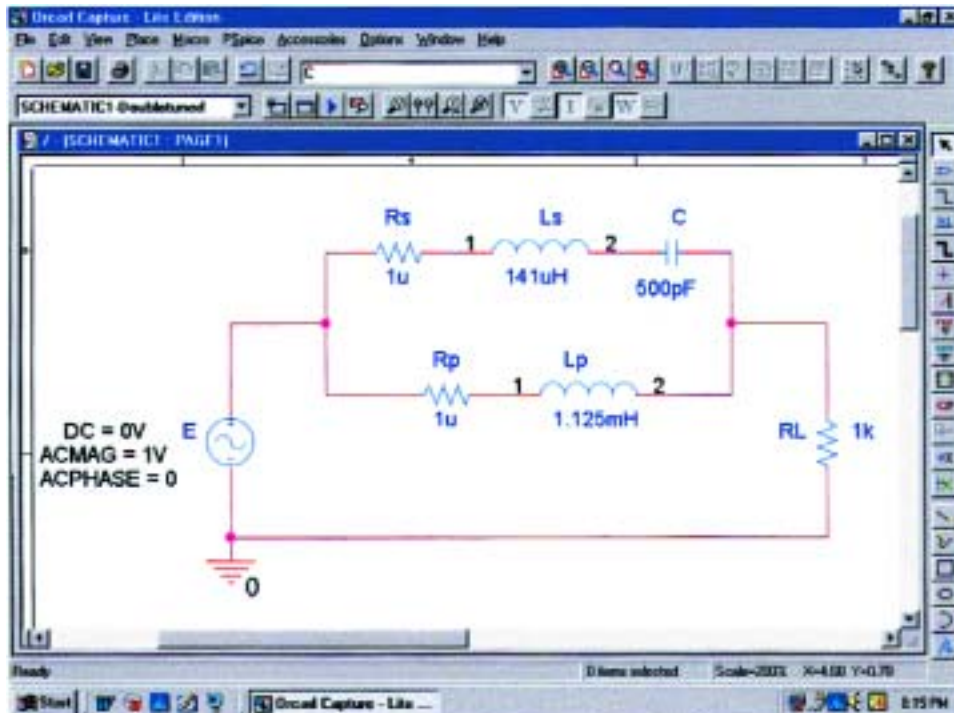

FIG. 23.95

Using PSpice to analyze a double-tuned filter.

were set in the **Property Editor** box rather than by selecting the components from the screen. Note the need for the two resistors in series with the inductors since inductors cannot be considered ideal elements. The small value of the resistive elements, however, will have no effect on the results obtained.

In the **Simulation Settings** dialog box, **AC Sweep** was again selected with a **Start Frequency** of 100 Hz and an **End Frequency** of 10 MHz (be sure to enter this value as **10MEGHZ**) to ensure that the full-range effect is provided. We can then use the axis controls to close in on the desired plot. The **Points/Decade** remains at 10k, although with this range of frequencies it may take a few seconds to simulate. Once the **SCHEMATIC1** appears, **Trace-Add Trace-V(RL:1)-OK** will result in the plot of Fig. 23.96. Quite obviously there is a reject-band around 200 kHz and a pass-band around 600 kHz. Isn't it interesting that up to 10 kHz we have another pass-band as the inductor  $L_p$  provides an almost direct path of low impedance from input to output. At frequencies approaching 10 MHz, there is a continuous stop-band due to the open-circuit equivalence of the  $L_p$  inductor. Using the cursor option, we can place the left-click cursor on the minimum point of the graph by using the **Cursor Trough** key pad (the second pad to the right of the **Toggle cursor** pad). The right click can be used to identify the frequency of the maximum point on the curve near 600 kHz. The results appearing in the **Probe Cursor** box clearly support our theoretical calculations of 200 kHz for the band-stop minimum (**A1** = 200.02 kHz with a magnitude of essentially 0 V) and 600 kHz for the pass-band maximum (**A2** = 603.115 kHz with a magnitude of 1 V).

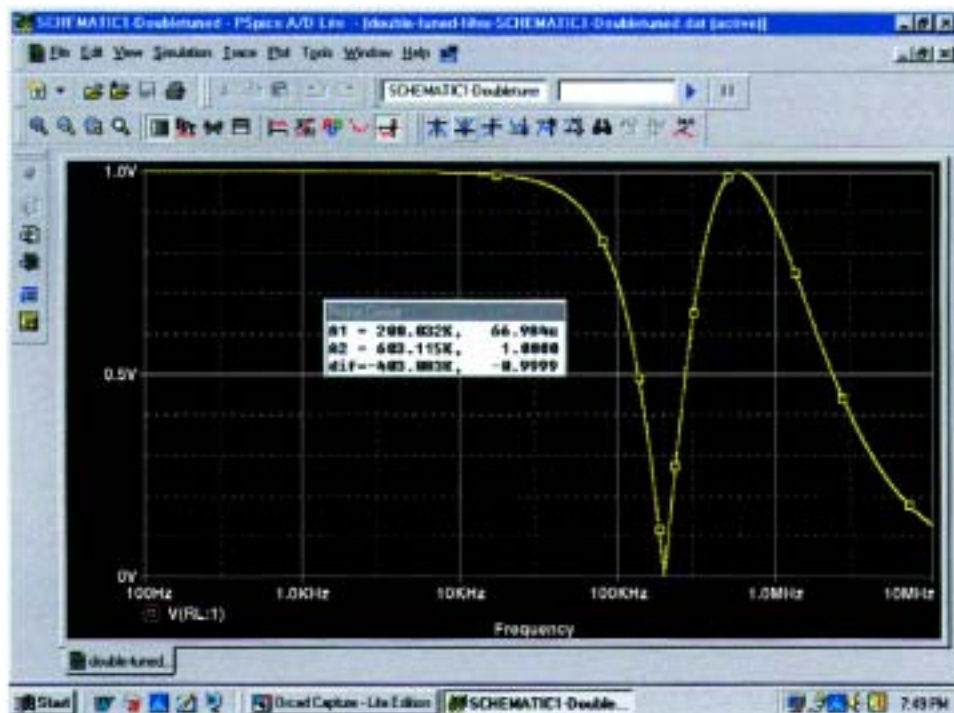

FIG. 23.96

Magnitude plot versus frequency for the voltage across  $R_L$  of the network of Fig. 23.95.

Let us now concentrate on the range from 10 kHz to 1 MHz where most of the filtering action is taking place. That was the advantage of choosing such a wide range of frequencies when the **Simulation Settings** were set up. The data have been established for the broad range of frequencies, and you can simply select a band of interest once the region of most activity is defined. If the frequency range were too narrow in the original simulation, another simulation would have to be defined. Select **Plot-Axis Settings-X Axis-User Defined-10kHz to 1MEGhz-OK** to obtain the plot at the bottom of Fig. 23.97. A dB plot of the results can also be displayed in the same figure by selecting **Plot-Add Plot to Window-Trace-Add Trace-DB(V(RL:1))-OK**, resulting in the plot at the top of the figure. Using our left-click cursor option and the **Cursor Trough** key, we find that the minimum is at  $-83.48$  dB at a frequency of 200 kHz, which is an excellent characteristic for a band-stop filter. Using the right-click cursor and setting it on 600 kHz, we find that the drop is  $-30.11$   $\mu$ dB or essentially 0 dB, which is excellent for the pass-band region.

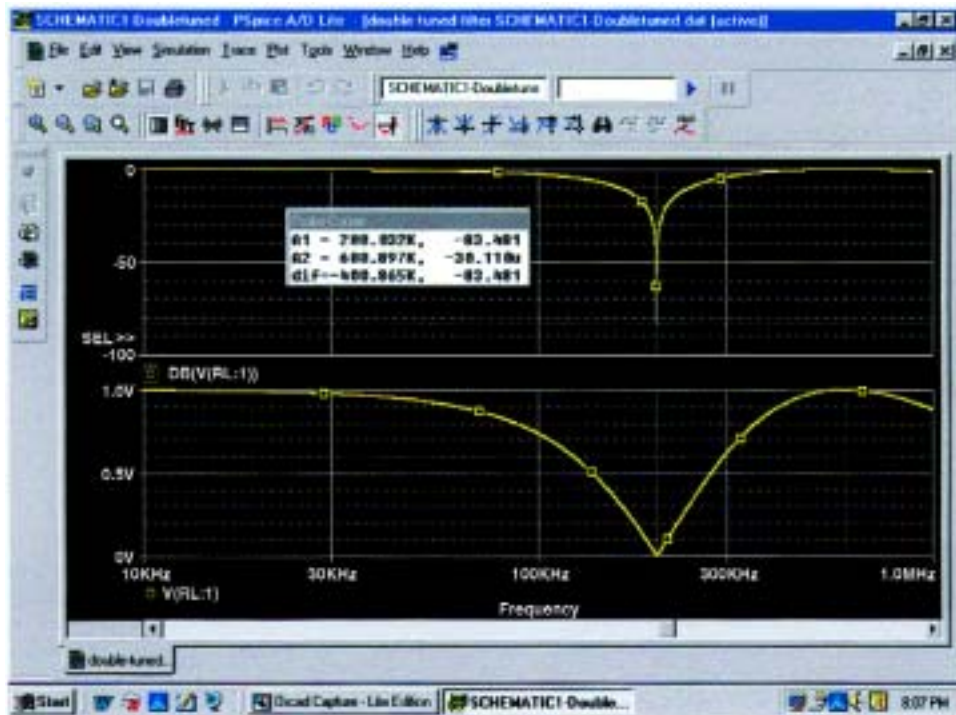

FIG. 23.97

*dB and magnitude plot for the voltage across  $R_L$  of the network of Fig. 23.95.*

## PROBLEMS

### SECTION 23.1 Logarithms

1. a. Determine the frequencies (in kHz) at the points indicated on the plot of Fig. 23.98(a).
- b. Determine the voltages (in mV) at the points indicated on the plot of Fig. 23.98(b).

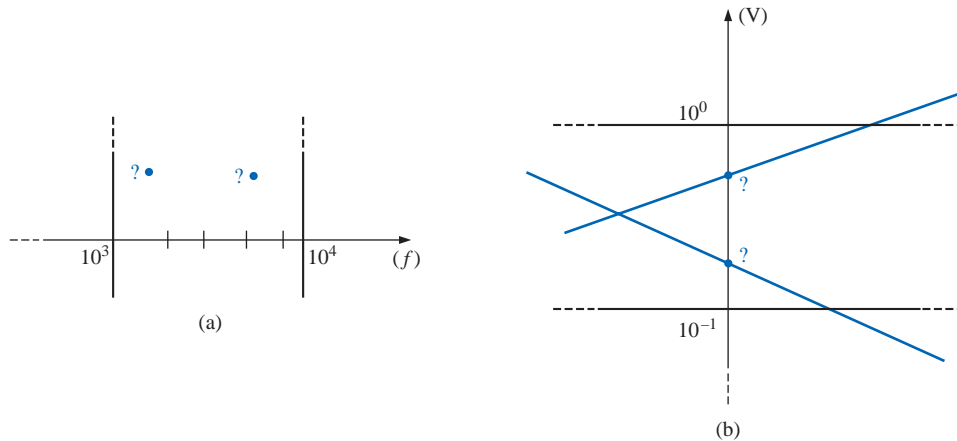

FIG. 23.98  
Problem 1.

### SECTION 23.2 Properties of Logarithms

2. Determine  $\log_{10} x$  for each value of  $x$ .
 

|            |              |
|------------|--------------|
| a. 100,000 | b. 0.0001    |
| c. $10^8$  | d. $10^{-6}$ |
| e. 20      | f. 8643.4    |
| g. 56,000  | h. 0.318     |
3. Given  $N = \log_{10} x$ , determine  $x$  for each value of  $N$ .
 

|          |         |
|----------|---------|
| a. 3     | b. 12   |
| c. 0.2   | d. 0.04 |
| e. 10    | f. 3.18 |
| g. 1.001 | h. 6.1  |
4. Determine  $\log_e x$  for each value of  $x$ .
 

|            |           |
|------------|-----------|
| a. 100,000 | b. 0.0001 |
| c. 20      | d. 8643.4 |

 Compare with the solutions to Problem 2.
5. Determine  $\log_{10} 48 = \log_{10}(8)(6)$ , and compare to  $\log_{10} 8 + \log_{10} 6$ .
6. Determine  $\log_{10} 0.2 = \log_{10} 18/90$ , and compare to  $\log_{10} 18 - \log_{10} 90$ .
7. Verify that  $\log_{10} 0.5$  is equal to  $-\log_{10} 1/0.5 = -\log_{10} 2$ .
8. Find  $\log_{10}(3)^3$ , and compare with  $3 \log_{10} 3$ .

### SECTION 23.3 Decibels

9. a. Determine the number of bels that relate power levels of  $P_2 = 280$  mW and  $P_1 = 4$  mW.  
 b. Determine the number of decibels for the power levels of part (a), and compare results.
10. A power level of 100 W is 6 dB above what power level?

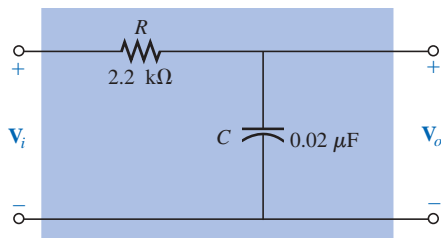

FIG. 23.99  
Problem 19.

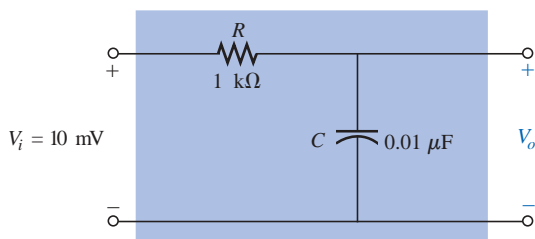

FIG. 23.100  
Problem 20.

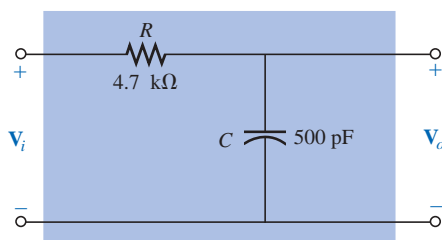

FIG. 23.101  
Problem 22.

11. If a 2-W speaker is replaced by one with a 40-W output, what is the increase in decibel level?
12. Determine the  $\text{dB}_m$  level for an output power of 120 mW.
13. Find the  $\text{dB}_v$  gain of an amplifier that raises the voltage level from 0.1 mV to 8.4 mV.
14. Find the output voltage of an amplifier if the applied voltage is 20 mV and a  $\text{dB}_v$  gain of 22 dB is attained.
15. If the sound pressure level is increased from  $0.001 \mu\text{bar}$  to  $0.016 \mu\text{bar}$ , what is the increase in  $\text{dB}_s$  level?
16. What is the required increase in acoustical power to raise a sound level from that of quiet music to very loud music? Use Fig. 23.5.
17.
  - a. Using semilog paper, plot  $X_L$  versus frequency for a 10-mH coil and a frequency range of 100 Hz to 1 MHz. Choose the best vertical scaling for the range of  $X_L$ .
  - b. Repeat part (a) using log-log graph paper. Compare to the results of part (a). Which plot is more informative?
  - c. Using semilog paper, plot  $X_C$  versus frequency for a 1- $\mu\text{F}$  capacitor and a frequency range of 10 Hz to 100 kHz. Again choose the best vertical scaling for the range of  $X_C$ .
  - d. Repeat part (a) using log-log graph paper. Compare to the results of part (c). Which plot is more informative?
18.
  - a. For the meter of Fig. 23.6, find the power delivered to a load for an 8-dB reading.
  - b. Repeat part (a) for a -5-dB reading.

### SECTION 23.5 R-C Low-Pass Filter

19. For the R-C low-pass filter of Fig. 23.99:
  - a. Sketch  $A_v = V_o/V_i$  versus frequency using a log scale for the frequency axis. Determine  $A_v = V_o/V_i$  at  $0.1f_c$ ,  $0.5f_c$ ,  $f_c$ ,  $2f_c$ , and  $10f_c$ .
  - b. Sketch the phase plot of  $\theta$  versus frequency, where  $\theta$  is the angle by which  $V_o$  leads  $V_i$ . Determine  $\theta$  at  $f = 0.1f_c$ ,  $0.5f_c$ ,  $f_c$ ,  $2f_c$ , and  $10f_c$ .
- \*20. For the network of Fig. 23.100:
  - a. Determine  $V_o$  at a frequency one octave above the critical frequency.
  - b. Determine  $V_o$  at a frequency one decade below the critical frequency.
  - c. Do the levels of parts (a) and (b) verify the expected frequency plot of  $V_o$  versus frequency for the filter?
21. Design an R-C low-pass filter to have a cutoff frequency of 500 Hz using a resistor of 1.2 k $\Omega$ . Then sketch the resulting magnitude and phase plot for a frequency range of  $0.1f_c$  to  $10f_c$ .
22. For the low-pass filter of Fig. 23.101:
  - a. Determine  $f_c$ .
  - b. Find  $A_v = V_o/V_i$  at  $f = 0.1f_c$ , and compare to the maximum value of 1 for the low-frequency range.
  - c. Find  $A_v = V_o/V_i$  at  $f = 10f_c$ , and compare to the minimum value of 0 for the high-frequency range.
  - d. Determine the frequency at which  $A_v = 0.01$  or  $V_o = \frac{1}{100}V_i$ .

## SECTION 23.6 R-C High-Pass Filter

23. For the R-C high-pass filter of Fig. 23.102:
- Sketch  $A_v = V_o/V_i$  versus frequency using a log scale for the frequency axis. Determine  $A_v = V_o/V_i$  at  $f_c$ , one octave above and below  $f_c$ , and one decade above and below  $f_c$ .
  - Sketch the phase plot of  $\theta$  versus frequency, where  $\theta$  is the angle by which  $V_o$  leads  $V_i$ . Determine  $\theta$  at the same frequencies noted in part (a).
24. For the network of Fig. 23.103:
- Determine  $A_v = V_o/V_i$  at  $f = f_c$  for the high-pass filter.
  - Determine  $A_v = V_o/V_i$  at two octaves above  $f_c$ . Is the rise in  $V_o$  significant from the  $f = f_c$  level?
  - Determine  $A_v = V_o/V_i$  at two decades above  $f_c$ . Is the rise in  $V_o$  significant from the  $f = f_c$  level?
  - If  $V_i = 10$  mV, what is the power delivered to  $R$  at the critical frequency?
25. Design a high-pass R-C filter to have a cutoff or corner frequency of 2 kHz, given a capacitor of 0.1  $\mu$ F. Choose the closest commercial value for  $R$ , and then recalculate the resulting corner frequency. Sketch the normalized gain  $A_v = V_o/V_i$  for a frequency range of  $0.1f_c$  to  $10f_c$ .
26. For the high-pass filter of Fig. 23.104:
- Determine  $f_c$ .
  - Find  $A_v = V_o/V_i$  at  $f = 0.01f_c$ , and compare to the minimum level of 0 for the low-frequency region.
  - Find  $A_v = V_o/V_i$  at  $f = 100f_c$ , and compare to the maximum level of 1 for the high-frequency region.
  - Determine the frequency at which  $V_o = \frac{1}{2}V_i$ .

## SECTION 23.7 Pass-Band Filters

27. For the pass-band filter of Fig. 23.105:
- Sketch the frequency response of  $A_v = V_o/V_i$  against a log scale extending from 10 Hz to 10 kHz.
  - What are the bandwidth and the center frequency?
- \*28. Design a pass-band filter such as the one appearing in Fig. 23.105 to have a low cutoff frequency of 4 kHz and a high cutoff frequency of 80 kHz.
29. For the pass-band filter of Fig. 23.106:
- Determine  $f_s$ .
  - Calculate  $Q_s$  and the BW for  $V_o$ .
  - Sketch  $A_v = V_o/V_i$  for a frequency range of 1 kHz to 1 MHz.
  - Find the magnitude of  $V_o$  at  $f = f_s$  and the cutoff frequencies.

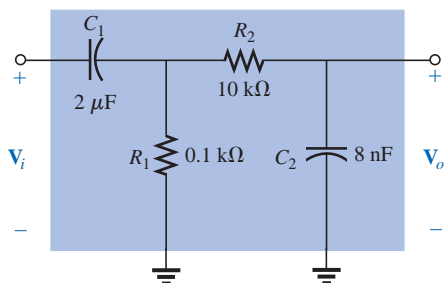

FIG. 23.105  
Problems 27 and 28.

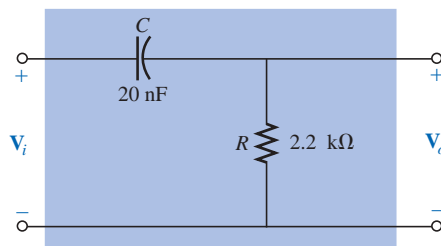

FIG. 23.102  
Problem 23.

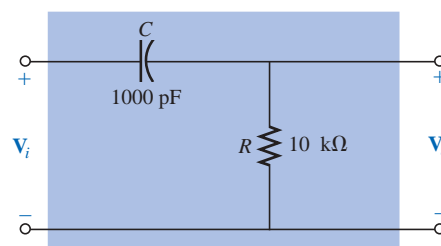

FIG. 23.103  
Problem 24.

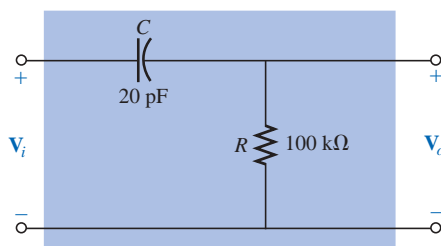

FIG. 23.104  
Problems 26 and 54.

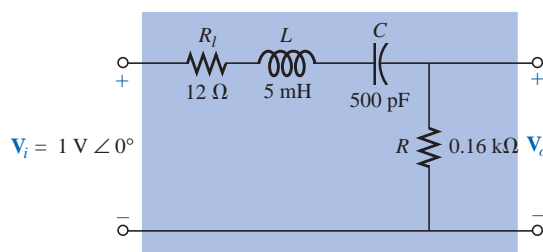
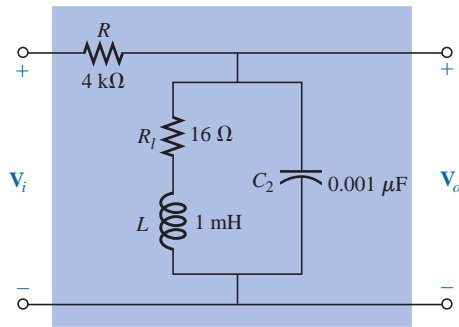
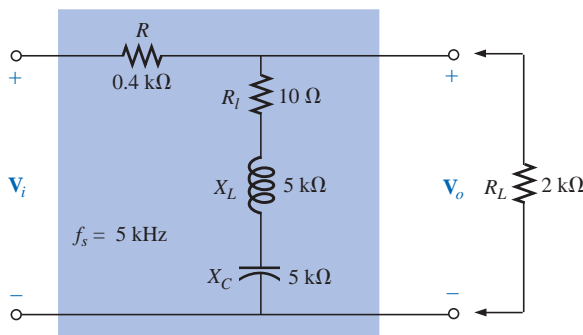

FIG. 23.106  
Problem 29.



**FIG. 23.107**  
Problems 30 and 55.



**FIG. 23.108**  
Problem 31.

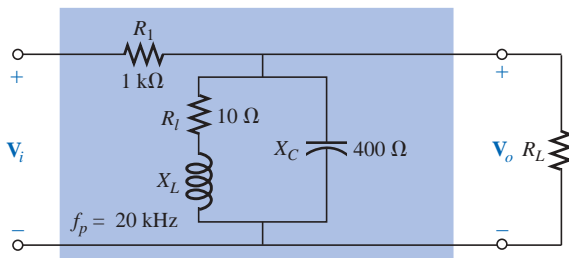

**FIG. 23.109**  
Problem 32.

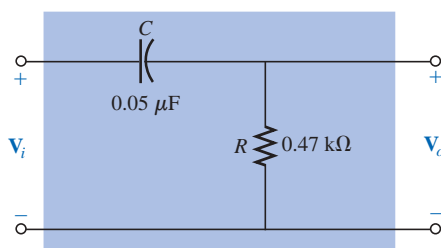

**FIG. 23.110**  
Problem 35.

30. For the pass-band filter of Fig. 23.107:
- Determine the frequency response of  $A_v = V_o/V_i$  for a frequency range of 100 Hz to 1 MHz.
  - Find the quality factor  $Q_p$  and the  $BW$  of the response.

### SECTION 23.8 Stop-Band Filters

- \*31. For the stop-band filter of Fig. 23.108:
- Determine  $Q_s$ .
  - Find the bandwidth and the half-power frequencies.
  - Sketch the frequency characteristics of  $A_v = V_o/V_i$ .
  - What is the effect on the curve of part (c) if a load of 2 kΩ is applied?
- \*32. For the pass-band filter of Fig. 23.109:
- Determine  $Q_p$  ( $R_L = \infty \Omega$ , an open circuit).
  - Sketch the frequency characteristics of  $A_v = V_o/V_i$ .
  - Find  $Q_p$  (loaded) for  $R_L = 100 \text{ k}\Omega$ , and indicate the effect of  $R_L$  on the characteristics of part (b).
  - Repeat part (c) for  $R_L = 20 \text{ k}\Omega$ .

### SECTION 23.9 Double-Tuned Filter

33. a. For the network of Fig. 23.43(a), if  $L_p = 400 \mu\text{H}$  ( $Q > 10$ ),  $L_s = 60 \mu\text{H}$ , and  $C = 120 \text{ pF}$ , determine the rejected and accepted frequencies.
- b. Sketch the response curve for part (a).
34. a. For the network of Fig. 23.43(b), if the rejected frequency is 30 kHz and the accepted is 100 kHz, determine the values of  $L_s$  and  $L_p$  ( $Q > 10$ ) for a capacitance of 200 pF.
- b. Sketch the response curve for part (a).

### SECTION 23.10 Bode Plots

35. a. Sketch the idealized Bode plot for  $A_v = V_o/V_i$  for the high-pass filter of Fig. 23.110.
- b. Using the results of part (a), sketch the actual frequency response for the same frequency range.
- c. Determine the decibel level at  $f_c$ ,  $\frac{1}{2}f_c$ ,  $2f_c$ ,  $\frac{1}{10}f_c$ , and  $10f_c$ .
- d. Determine the gain  $A_v = V_o/V_i$  as  $f = f_c$ ,  $\frac{1}{2}f_c$ , and  $2f_c$ .
- e. Sketch the phase response for the same frequency range.
- \*36. a. Sketch the response of the magnitude of  $V_o$  (in terms of  $V_i$ ) versus frequency for the high-pass filter of Fig. 23.111.
- b. Using the results of part (a), sketch the response  $A_v = V_o/V_i$  for the same frequency range.
- c. Sketch the idealized Bode plot.

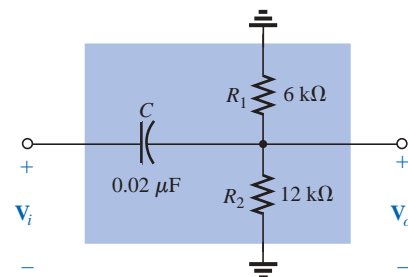

**FIG. 23.111**  
Problem 36.

- d. Sketch the actual response, indicating the dB difference between the idealized and the actual response at  $f = f_c$ ,  $0.5f_c$ , and  $2f_c$ .
- e. Determine  $A_{v_{dB}}$  at  $f = 1.5f_c$  from the plot of part (d), and then determine the corresponding magnitude of  $A_v = V_o/V_i$ .
- f. Sketch the phase response for the same frequency range (the angle by which  $V_o$  leads  $V_i$ ).
37. a. Sketch the idealized Bode plot for  $A_v = V_o/V_i$  for the low-pass filter of Fig. 23.112.
- b. Using the results of part (a), sketch the actual frequency response for the same frequency range.
- c. Determine the decibel level at  $f_c$ ,  $\frac{1}{2}f_c$ ,  $2f_c$ ,  $\frac{1}{10}f_c$ , and  $10f_c$ .
- d. Determine the gain  $A_v = V_o/V_i$  at  $f = f_c$ ,  $\frac{1}{2}f_c$ , and  $2f_c$ .
- e. Sketch the phase response for the same frequency range.
- \*38. a. Sketch the response of the magnitude of  $V_o$  (in terms of  $V_i$ ) versus frequency for the low-pass filter of Fig. 23.113.
- b. Using the results of part (a), sketch the response  $A_v = V_o/V_i$  for the same frequency range.
- c. Sketch the idealized Bode plot.
- d. Sketch the actual response indicating the dB difference between the idealized and the actual response at  $f = f_c$ ,  $0.5f_c$ , and  $2f_c$ .
- e. Determine  $A_{v_{dB}}$  at  $f = 0.25f_c$  from the plot of part (d), and then determine the corresponding magnitude of  $A_v = V_o/V_i$ .
- f. Sketch the phase response for the same frequency range (the angle by which  $V_o$  leads  $V_i$ ).

### SECTION 23.11 Sketching the Bode Response

39. For the filter of Fig. 23.114:
- a. Sketch the curve of  $A_{v_{dB}}$  versus frequency using a log scale.
- b. Sketch the curve of  $\theta$  versus frequency for the same frequency range as in part (a).
- \*40. For the filter of Fig. 23.115:
- a. Sketch the curve of  $A_{v_{dB}}$  versus frequency using a log scale.
- b. Sketch the curve of  $\theta$  versus frequency for the same frequency range as in part (a).

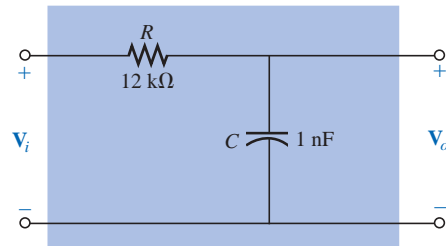

FIG. 23.112

Problem 37.

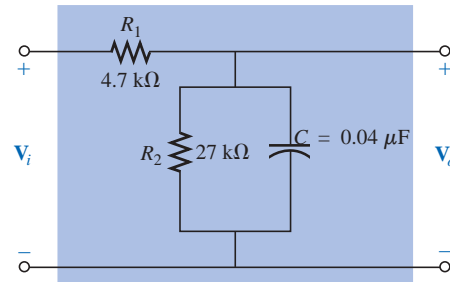

FIG. 23.113

Problem 38.

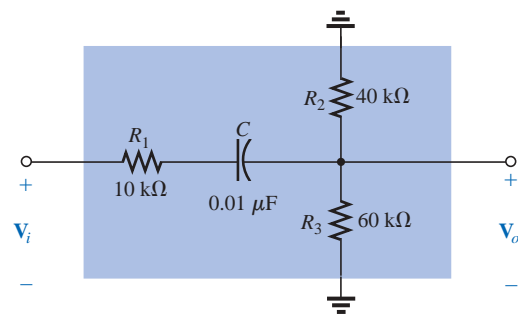

FIG. 23.114

Problem 39.

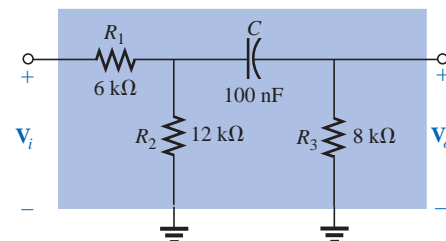

FIG. 23.115

Problem 40.

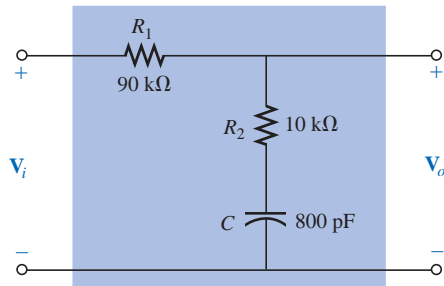

FIG. 23.116  
Problem 41.

### SECTION 23.12 Low-Pass Filter with Limited Attenuation

41. For the filter of Fig. 23.116:
- Sketch the curve of  $A_{v_{dB}}$  versus frequency using the idealized Bode plots as a guide.
  - Sketch the curve of  $\theta$  versus frequency.
- \*42. For the filter of Fig. 23.117:
- Sketch the curve of  $A_{v_{dB}}$  versus frequency using the idealized Bode plots as a guide.
  - Sketch the curve of  $\theta$  versus frequency.

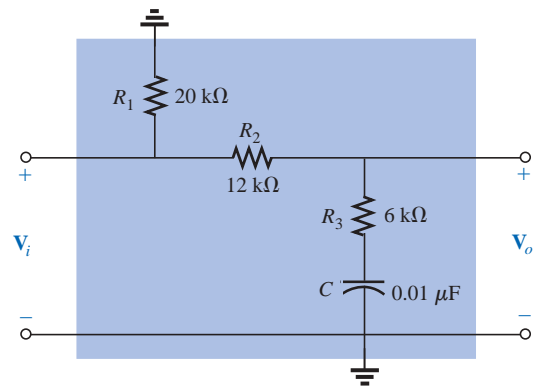

FIG. 23.117  
Problem 42.

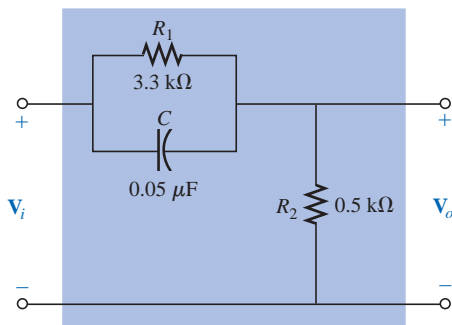

FIG. 23.118  
Problem 43.

### SECTION 23.13 High-Pass Filter with Limited Attenuation

43. For the filter of Fig. 23.118:
- Sketch the curve of  $A_{v_{dB}}$  versus frequency using the idealized Bode plots as an envelope for the actual response.
  - Sketch the curve of  $\theta$  (the angle by which  $V_o$  leads  $V_i$ ) versus frequency.
- \*44. For the filter of Fig. 23.119:
- Sketch the curve of  $A_{v_{dB}}$  versus frequency using the idealized Bode plots as an envelope for the actual response.
  - Sketch the curve of  $\theta$  (the angle by which  $V_o$  leads  $V_i$ ) versus frequency.

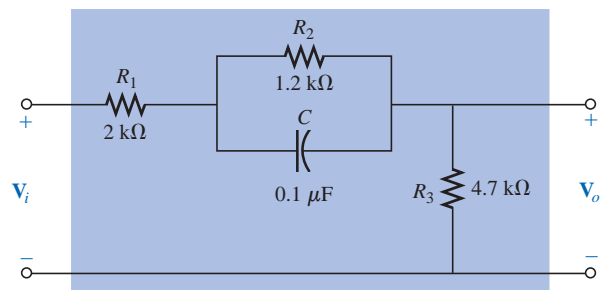

FIG. 23.119  
Problem 44.

### SECTION 23.14 Other Properties and a Summary Table

45. A bipolar transistor amplifier has the following gain:

$$A_v = \frac{160}{\left(1 - j \frac{100 \text{ Hz}}{f}\right) \left(1 - j \frac{130 \text{ Hz}}{f}\right) \left(1 + j \frac{f}{20 \text{ kHz}}\right) \left(1 + j \frac{f}{50 \text{ kHz}}\right)}$$

- Sketch the normalized Bode response  $A'_{v_{dB}} = (A_v/A_{v_{max}})_{dB}$ , and determine the bandwidth of the amplifier. Be sure to note the corner frequencies.
- Sketch the phase response, and determine a frequency where the phase angle is relatively close to  $45^\circ$ .

46. A JFET transistor amplifier has the following gain:

$$A_v = \frac{-5.6}{\left(1 - j \frac{10 \text{ Hz}}{f}\right) \left(1 - j \frac{45 \text{ Hz}}{f}\right) \left(1 - j \frac{68 \text{ Hz}}{f}\right) \left(1 + j \frac{f}{23 \text{ kHz}}\right) \left(1 + j \frac{f}{50 \text{ kHz}}\right)}$$

- Sketch the normalized Bode response  $A'_{v_{dB}} = (A_v/A_{v_{max}})_{dB}$ , and determine the bandwidth of the amplifier. When you normalize, be sure that the maximum value of  $A'_v$  is +1. Clearly indicate the cutoff frequencies on the plot.
- Sketch the phase response, and note the regions of greatest change in phase angle. How do the regions correspond to the frequencies appearing in the function  $A_v$ ?

47. A transistor amplifier has a midband gain of  $-120$ , a high cutoff frequency of  $36 \text{ kHz}$ , and a bandwidth of  $35.8 \text{ kHz}$ . In addition, the actual response is also about  $-15 \text{ dB}$  at  $f = 50 \text{ Hz}$ . Write the transfer function  $A_v$  for the amplifier.

48. Sketch the Bode plot of the following function:

$$A_v = \frac{0.05}{0.05 - j 100/f}$$

49. Sketch the Bode plot of the following function:

$$A_v = \frac{200}{200 + j 0.1f}$$

50. Sketch the Bode plot of the following function:

$$A_v = \frac{jf/1000}{(1 + jf/1000)(1 + jf/10,000)}$$

\*51. Sketch the Bode plot of the following function:

$$A_v = \frac{(1 + jf/1000)(1 + jf/2000)}{(1 + jf/3000)^2}$$

\*52. Sketch the Bode plot of the following function (note the presence of  $\omega$  rather than  $f$ ):

$$A_v = \frac{40(1 + j 0.001\omega)}{(j 0.001\omega)(1 + j 0.0002\omega)}$$

### SECTION 23.15 Crossover Networks

\*53. The three-way crossover network of Fig. 23.120 has a 12-dB rolloff at the cutoff frequencies.

- Determine the ratio  $V_o/V_i$  for the woofer and tweeter at the cutoff frequencies of  $400 \text{ Hz}$  and  $5 \text{ kHz}$ , respectively, and compare to the desired level of  $0.707$ .

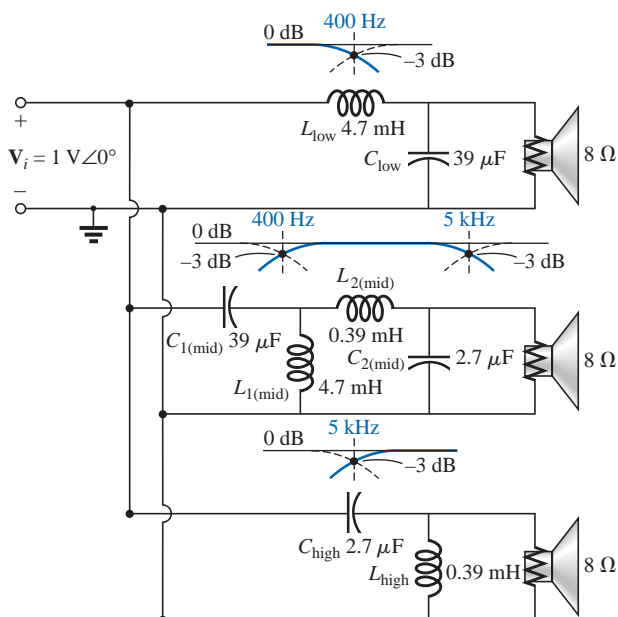

FIG. 23.120  
Problems 53 and 57.

- b. Calculate the ratio  $V_o/V_i$  for the woofer and tweeter at a frequency of 3 kHz, where the midrange speaker is designed to predominate.
- c. Determine the ratio  $V_o/V_i$  for the midrange speaker at a frequency of 3 kHz, and compare to the desired level of 1.

### SECTION 23.17 Computer Analysis

#### PSpice or Electronics Workbench

54. Using schematics, obtain the magnitude and phase response versus frequency for the network of Fig. 23.104.
55. Using schematics, obtain the magnitude and phase response versus frequency for the network of Fig. 23.107.
- \*56. Obtain the dB and phase plots for the network of Fig. 23.75, and compare with the plots of Figs. 23.76 and 23.77.
- \*57. Using schematics, obtain the magnitude and dB plot versus frequency for each filter of Fig. 23.120, and verify that the curves drop off at 12 dB per octave.

#### Programming Language (C++, QBASIC, Pascal, etc.)

58. Write a program that will tabulate the gain of Eq. (23.14) versus frequency for a frequency range extending from  $0.1f_1$  to  $2f_1$  in increments of  $0.1f_1$ . Note whether  $f = f_1$  when  $V_o/V_i = 0.707$ . Use  $R = 1 \text{ k}\Omega$  and  $C = 500 \text{ pF}$ .
59. Write a program to tabulate  $A_{v_{dB}}$  as determined from Eq. (23.34) and  $A_{v_{dB}}$  as calculated by Eq. (23.35). For a frequency range extending from  $0.01f_1$  to  $f_1$  in increments of  $0.01f_1$ , compare the magnitudes, and note whether the values are closer when  $f \ll f_1$  and whether  $A_{v_{dB}} = -3 \text{ dB}$  at  $f = f_1$  for Eq. (23.34) and zero for Eq. (23.35).

## GLOSSARY

**Active filter** A filter that employs active devices such as transistors or operational amplifiers in combination with  $R$ ,  $L$ , and  $C$  elements.

**Bode plot** A plot of the frequency response of a system using straight-line segments called asymptotes.

**Decibel** A unit of measurement used to compare power levels.

**Double-tuned filter** A network having both a pass-band and a stop-band region.

**Filter** Networks designed to either pass or reject the transfer of signals at certain frequencies to a load.

**High-pass filter** A filter designed to pass high frequencies and reject low frequencies.

**Log-log paper** Graph paper with vertical and horizontal log scales.

**Low-pass filter** A filter designed to pass low frequencies and reject high frequencies.

**Microbar ( $\mu\text{bar}$ )** A unit of measurement for sound pressure levels that permits comparing audio levels on a dB scale.

**Pass-band (band-pass) filter** A network designed to pass signals within a particular frequency range.

**Passive filter** A filter constructed of series, parallel, or series-parallel  $R$ ,  $L$ , and  $C$  elements.

**Semilog paper** Graph paper with one log scale and one linear scale.

**Stop-band filter** A network designed to reject (block) signals within a particular frequency range.