

# Pulse Waveforms and the $R$ - $C$ Response

## 24.1 INTRODUCTION

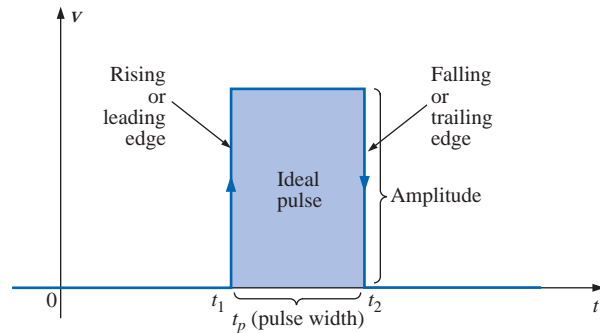
Our analysis thus far has been limited to alternating waveforms that vary in a sinusoidal manner. This chapter will introduce the basic terminology associated with the pulse waveform and will examine the response of an  $R$ - $C$  circuit to a square-wave input. The importance of the pulse waveform to the electrical/electronics industry cannot be overstated. A vast array of instrumentation, communication systems, computers, radar systems, and so on, all employ pulse signals to control operation, transmit data, and display information in a variety of formats.

The response of the networks described thus far to a pulse signal is quite different from that obtained for sinusoidal signals. In fact, we will be returning to the dc chapter on capacitors (Chapter 10) to retrieve a few fundamental concepts and equations that will help us in the analysis to follow. The content of this chapter is quite introductory in nature, designed simply to provide the fundamentals that will be helpful when the pulse waveform is encountered in specific areas of application.

## 24.2 IDEAL VERSUS ACTUAL

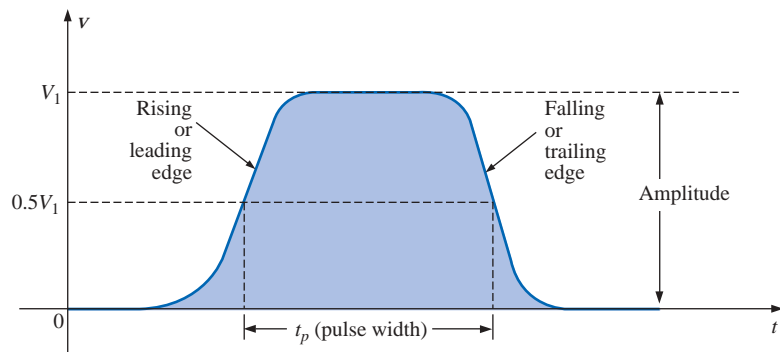
The **ideal pulse** of Fig. 24.1 has vertical sides, sharp corners, and a flat peak characteristic; it starts instantaneously at  $t_1$  and ends just as abruptly at  $t_2$ .

The waveform of Fig. 24.1 will be applied in the analysis to follow in this chapter and will probably appear in the initial investigation of areas of application beyond the scope of this text. Once the fundamental operation of a device, package, or system is clearly understood using ideal characteristics, the effect of an **actual** (or **true** or **practical**) pulse must be considered. If an attempt were made to introduce all the differences between an ideal and actual pulse in a single figure, the result would probably be complex and confusing. A number of waveforms will therefore be used to define the critical parameters.



**FIG. 24.1**  
*Ideal pulse waveform.*

The reactive elements of a network, in their effort to prevent instantaneous changes in voltage (capacitor) and current (inductor), establish a slope to both edges of the pulse waveform, as shown in Fig. 24.2. The *rising edge* of the waveform of Fig. 24.2 is defined as the edge that increases from a lower to a higher level.



**FIG. 24.2**  
*Actual pulse waveform.*

*The falling edge is defined by the region or edge where the waveform decreases from a higher to a lower level. Since the rising edge is the first to be encountered (closest to  $t = 0$  s), it is also called the leading edge. The falling edge always follows the leading edge and is therefore often called the trailing edge.*

Both regions are defined in Figs. 24.1 and 24.2.

## Amplitude

For most applications, the **amplitude of a pulse waveform** is defined as the peak-to-peak value. Of course, if the waveforms all start and return to the zero-volt level, then the peak and peak-to-peak values are synonymous.

*For the purposes of this text, the amplitude of a pulse waveform is the peak-to-peak value, as illustrated in Figs. 24.1 and 24.2.*



## Pulse Width

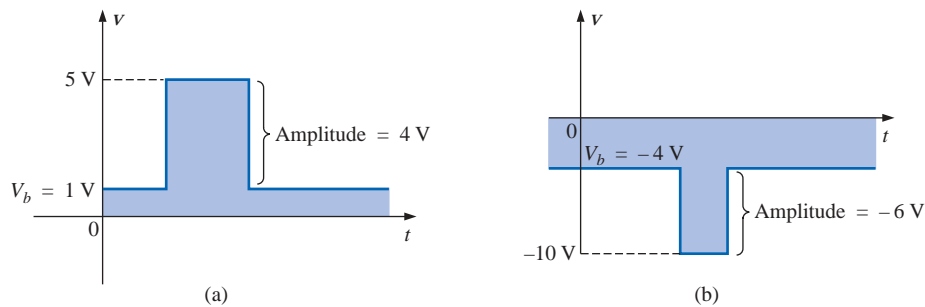
*The pulse width ( $t_p$ ), or pulse duration, is defined by a pulse level equal to 50% of the peak value.*

For the ideal pulse of Fig. 24.1, the pulse width is the same at any level, whereas  $t_p$  for the waveform of Fig. 24.2 is a very specific value.

## Base-Line Voltage

*The base-line voltage ( $V_b$ ) is the voltage level from which the pulse is initiated.*

The waveforms of Figs. 24.1 and 24.2 both have a 0-V base-line voltage. In Fig. 24.3(a) the base-line voltage is 1 V, whereas in Fig. 24.3(b) the base-line voltage is  $-4$  V.



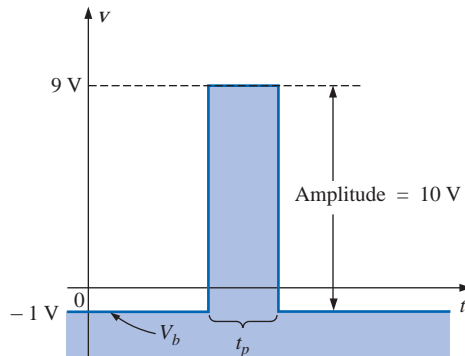
**FIG. 24.3**  
Defining the base-line voltage.

## Positive-Going and Negative-Going Pulses

*A positive-going pulse increases positively from the base-line voltage, whereas a negative-going pulse increases in the negative direction from the base-line voltage.*

The waveform of Fig. 24.3(a) is a positive-going pulse, whereas the waveform of Fig. 24.3(b) is a negative-going pulse.

Even though the base-line voltage of Fig. 24.4 is negative, the waveform is positive-going (with an amplitude of 10 V) since the voltage increased in the positive direction from the base-line voltage.



**FIG. 24.4**  
Positive-going pulse.



## Rise Time ( $t_r$ ) and Fall Time ( $t_f$ )

Of particular importance is the time required for the pulse to shift from one level to another. The *rounding* (defined in Fig. 24.5) that occurs at the beginning and end of each transition makes it difficult to define the exact point at which the rise time should be initiated and terminated. For this reason,

*the rise time and the fall time are defined by the 10% and 90% levels, as indicated in Fig. 24.5.*

Note that there is no requirement that  $t_r$  equal  $t_f$ .

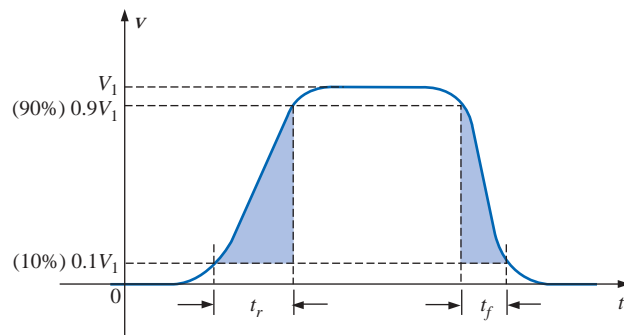


FIG. 24.5  
Defining  $t_r$  and  $t_f$ .

## Tilt

An undesirable but common distortion normally occurring due to a poor low-frequency response characteristic of the system through which a pulse has passed appears in Fig. 24.6. The drop in peak value is called **tilt**, **droop**, or **sag**. The percentage tilt is defined by

$$\% \text{ tilt} = \frac{V_1 - V_2}{V} \times 100\% \quad (24.1)$$

where  $V$  is the average value of the peak amplitude as determined by

$$V = \frac{V_1 + V_2}{2} \quad (24.2)$$

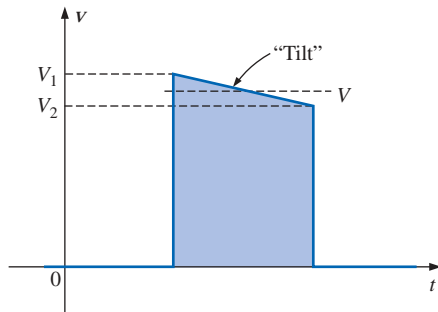


FIG. 24.6  
Defining tilt.

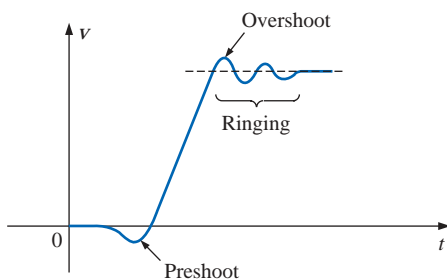


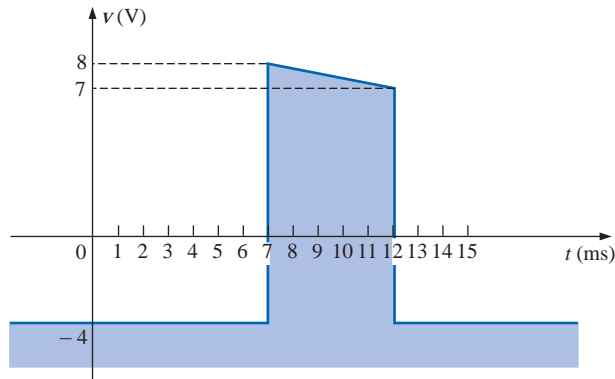
FIG. 24.7  
Defining preshoot, overshoot, and ringing.

Naturally, the less the percentage tilt or sag, the more ideal the pulse. Due to rounding, it may be difficult to define the values of  $V_1$  and  $V_2$ . It is then necessary only to approximate the sloping region by a straight-line approximation and use the resulting values of  $V_1$  and  $V_2$ .

Other distortions include the *preshoot* and *overshoot* appearing in Fig. 24.7, normally due to pronounced high-frequency effects of a system, and *ringing*, due to the interaction between the capacitive and inductive elements of a network at their natural or resonant frequency.

**EXAMPLE 24.1** Determine the following for the pulse waveform of Fig. 24.8:

- positive- or negative-going?
- base-line voltage



**FIG. 24.8**  
Example 24.1.

- c. pulse width
- d. maximum amplitude
- e. tilt

**Solutions:**

- a. **positive-going**
- b.  $V_b = -4 \text{ V}$
- c.  $t_p = (12 - 7) \text{ ms} = 5 \text{ ms}$
- d.  $V_{\max} = 8 \text{ V} + 4 \text{ V} = 12 \text{ V}$
- e.  $V = \frac{V_1 + V_2}{2} = \frac{12 \text{ V} + 11 \text{ V}}{2} = \frac{23 \text{ V}}{2} = 11.5 \text{ V}$

$$\% \text{ tilt} = \frac{V_1 - V_2}{V} \times 100\% = \frac{12 \text{ V} - 11 \text{ V}}{11.5 \text{ V}} \times 100\% = 8.696\%$$

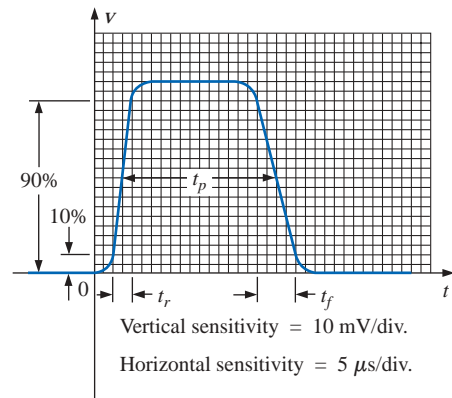
(Remember,  $V$  is defined by the average value of the peak amplitude.)

**EXAMPLE 24.2** Determine the following for the pulse waveform of Fig. 24.9:

- a. positive- or negative-going?
- b. base-line voltage
- c. tilt
- d. amplitude
- e.  $t_p$
- f.  $t_r$  and  $t_f$

**Solutions:**

- a. **positive-going**
- b.  $V_b = 0 \text{ V}$
- c. **% tilt = 0%**
- d. amplitude = (4 div.)(10 mV/div.) = **40 mV**
- e.  $t_p = (3.2 \text{ div.})(5 \mu\text{s}/\text{div.}) = 16 \mu\text{s}$
- f.  $t_r = (0.4 \text{ div.})(5 \mu\text{s}/\text{div.}) = 2 \mu\text{s}$   
 $t_f = (0.8 \text{ div.})(5 \mu\text{s}/\text{div.}) = 4 \mu\text{s}$



**FIG. 24.9**  
Example 24.2.

### 24.3 PULSE REPETITION RATE AND DUTY CYCLE

A series of pulses such as those appearing in Fig. 24.10 is called a **pulse train**. The varying widths and heights may contain information that can be decoded at the receiving end.

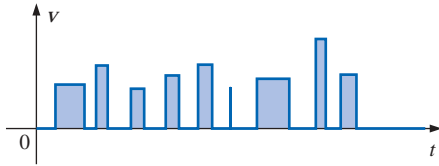


FIG. 24.10  
Pulse train.

If the pattern repeats itself in a periodic manner as shown in Fig. 24.11(a) and (b), the result is called a **periodic pulse train**.

The *period* ( $T$ ) of the pulse train is defined as the time differential between any two similar points on the pulse train, as shown in Figs. 24.11(a) and (b).

The **pulse repetition frequency** (prf), or **pulse repetition rate** (pr), is defined by

$$\text{prf (or pr)} = \frac{1}{T} \quad (\text{Hz or pulses/s}) \quad (24.3)$$

Applying Eq. (24.3) to each waveform of Fig. 24.11 will result in the same pulse repetition frequency since the periods are the same. The result clearly reveals that

*the shape of the periodic pulse does not affect the determination of the pulse repetition frequency.*

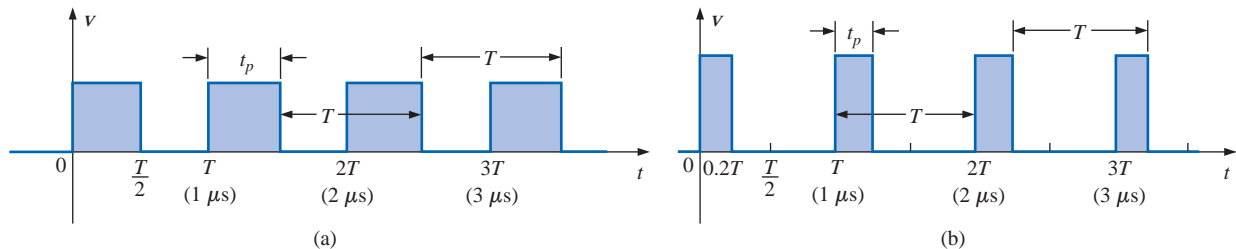


FIG. 24.11

Periodic pulse trains.

The pulse repetition frequency is determined solely by the period of the repeating pulse. The factor that will reveal how much of the period is encompassed by the pulse is called the **duty cycle**, defined as follows:

$$\text{Duty cycle} = \frac{\text{pulse width}}{\text{period}} \times 100\%$$

or

$$\text{Duty cycle} = \frac{t_p}{T} \times 100\% \quad (24.4)$$

For Fig. 24.11(a) (a square-wave pattern),

$$\text{Duty cycle} = \frac{0.5T}{T} \times 100\% = \mathbf{50\%}$$

and for Fig. 24.11(b),

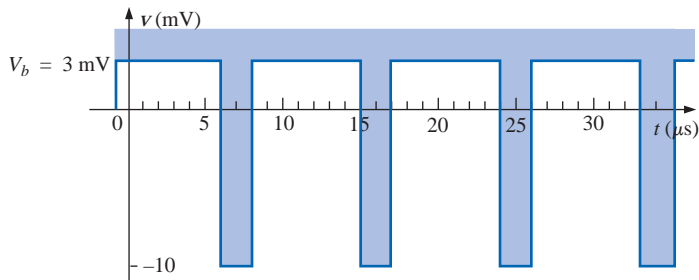
$$\text{Duty cycle} = \frac{0.2T}{T} \times 100\% = \mathbf{20\%}$$

The above results clearly reveal that

*the duty cycle provides a percentage indication of the portion of the total period encompassed by the pulse waveform.*



**EXAMPLE 24.3** Determine the pulse repetition frequency and the duty cycle for the periodic pulse waveform of Fig. 24.12.



**FIG. 24.12**  
Example 24.3.

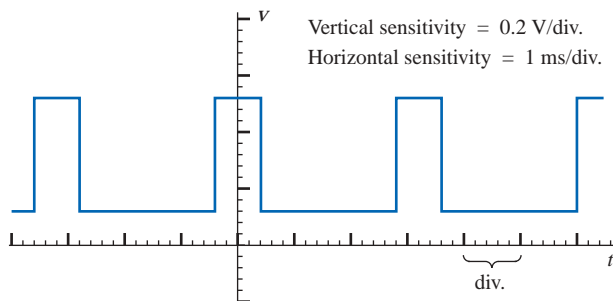
**Solution:**

$$T = (15 - 6) \mu\text{s} = 9 \mu\text{s}$$

$$\text{prf} = \frac{1}{T} = \frac{1}{9 \mu\text{s}} \cong \mathbf{111.11 \text{ kHz}}$$

$$\begin{aligned} \text{Duty cycle} &= \frac{t_p}{T} \times 100\% = \frac{(8 - 6) \mu\text{s}}{9 \mu\text{s}} \times 100\% \\ &= \frac{2}{9} \times 100\% \cong \mathbf{22.22\%} \end{aligned}$$

**EXAMPLE 24.4** Determine the pulse repetition frequency and the duty cycle for the oscilloscope pattern of Fig. 24.13 having the indicated sensitivities.



**FIG. 24.13**  
Example 24.4.

**Solution:**

$$T = (3.2 \text{ div.})(1 \text{ ms/div.}) = 3.2 \text{ ms}$$

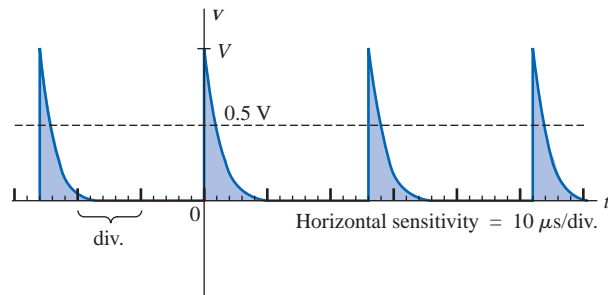
$$t_p = (0.8 \text{ div.})(1 \text{ ms/div.}) = 0.8 \text{ ms}$$

$$\text{prf} = \frac{1}{T} = \frac{1}{3.2 \text{ ms}} = \mathbf{312.5 \text{ Hz}}$$

$$\text{Duty cycle} = \frac{t_p}{T} \times 100\% = \frac{0.8 \text{ ms}}{3.2 \text{ ms}} \times 100\% = \mathbf{25\%}$$



**EXAMPLE 24.5** Determine the pulse repetition rate and duty cycle for the trigger waveform of Fig. 24.14.



**FIG. 24.14**

Example 24.5.

**Solution:**

$$T = (2.6 \text{ div.})(10 \mu\text{s/div.}) = 26 \mu\text{s}$$

$$\text{prf} = \frac{1}{T} = \frac{1}{26 \mu\text{s}} = \mathbf{38,462 \text{ kHz}}$$

$$t_p \cong (0.2 \text{ div.})(10 \mu\text{s/div.}) = 2 \mu\text{s}$$

$$\text{Duty cycle} = \frac{t_p}{T} \times 100\% = \frac{2 \mu\text{s}}{26 \mu\text{s}} \times 100\% = \mathbf{7.69\%}$$

## 24.4 AVERAGE VALUE

The average value of a pulse waveform can be determined using one of two methods. The first is the procedure outlined in Section 13.6, which can be applied to any alternating waveform. The second can be applied only to pulse waveforms since it utilizes terms specifically related to pulse waveforms; that is,

$$V_{\text{av}} = (\text{duty cycle})(\text{peak value}) + (1 - \text{duty cycle})(V_b) \quad (24.5)$$

In Eq. (24.5), the peak value is the maximum deviation from the reference or zero-volt level, and the duty cycle is in decimal form. Equation (24.5) does not include the effect of any tilt pulse waveforms with sloping sides.

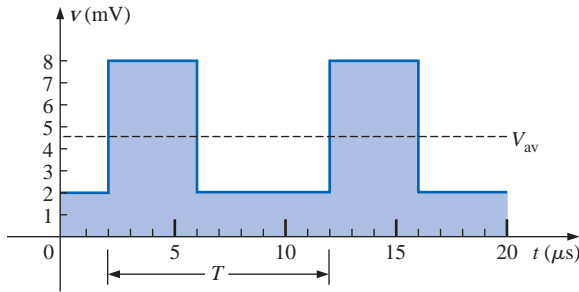
**EXAMPLE 24.6** Determine the average value for the periodic pulse waveform of Fig. 24.15.

**Solution:** By the method of Section 13.6,

$$G = \frac{\text{area under curve}}{T}$$

$$T = (12 - 2) \mu\text{s} = 10 \mu\text{s}$$

$$\begin{aligned} G &= \frac{(8 \text{ mV})(4 \mu\text{s}) + (2 \text{ mV})(6 \mu\text{s})}{10 \mu\text{s}} = \frac{32 \times 10^{-9} + 12 \times 10^{-9}}{10 \times 10^{-6}} \\ &= \frac{44 \times 10^{-9}}{10 \times 10^{-6}} = \mathbf{4.4 \text{ mV}} \end{aligned}$$



**FIG. 24.15**  
Example 24.6.

By Eq. (24.5),

$$V_b = +2 \text{ mV}$$

$$\text{Duty cycle} = \frac{t_p}{T} = \frac{(6 - 2) \mu\text{s}}{10 \mu\text{s}} = \frac{4}{10} = 0.4 \text{ (decimal form)}$$

$$\text{Peak value (from 0-V reference)} = 8 \text{ mV}$$

$$\begin{aligned} V_{av} &= (\text{duty cycle})(\text{peak value}) + (1 - \text{duty cycle})(V_b) \\ &= (0.4)(8 \text{ mV}) + (1 - 0.4)(2 \text{ mV}) \\ &= 3.2 \text{ mV} + 1.2 \text{ mV} = \mathbf{4.4 \text{ mV}} \end{aligned}$$

as obtained above.

**EXAMPLE 24.7** Given a periodic pulse waveform with a duty cycle of 28%, a peak value of 7 V, and a base-line voltage of  $-3 \text{ V}$ :

- Determine the average value.
- Sketch the waveform.
- Verify the result of part (a) using the method of Section 13.6.

**Solutions:**

- By Eq. (24.5),

$$\begin{aligned} V_{av} &= (\text{duty cycle})(\text{peak value}) + (1 - \text{duty cycle})(V_b) \\ &= (0.28)(7 \text{ V}) + (1 - 0.28)(-3 \text{ V}) = 1.96 \text{ V} + (-2.16 \text{ V}) \\ &= \mathbf{-0.2 \text{ V}} \end{aligned}$$

- See Fig. 24.16.

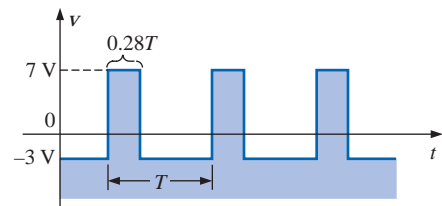
$$c. G = \frac{(7 \text{ V})(0.28T) - (3 \text{ V})(0.72T)}{T} = 1.96 \text{ V} - 2.16 \text{ V}$$

$$= \mathbf{-0.2 \text{ V}}$$

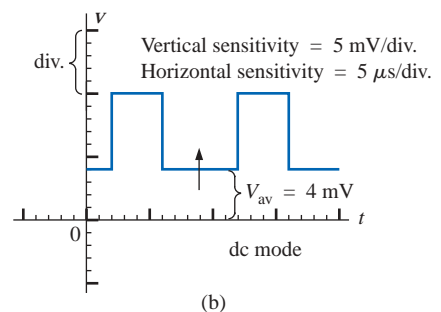
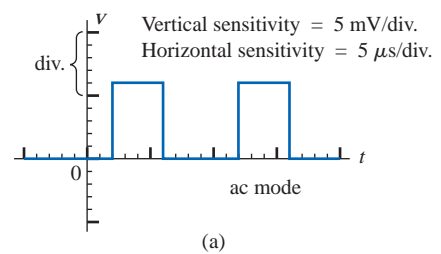
as obtained above.

**Instrumentation**

The average value (dc value) of any waveform can be easily determined using the oscilloscope. If the mode switch of the scope is set in the ac position, the average or dc component of the applied waveform will be blocked by an internal capacitor from reaching the screen. The pattern can be adjusted to establish the display of Fig. 24.17(a). If the mode switch is then placed in the dc position, the vertical shift (positive or



**FIG. 24.16**  
Solution to part (b) of Example 24.7.



**FIG. 24.17**  
Determining the average value of a pulse waveform using an oscilloscope.



negative) will reveal the average or dc level of the input signal, as shown in Fig. 24.17(b).

## 24.5 TRANSIENT R-C NETWORKS

In Chapter 10 the general solution for the transient behavior of an R-C network with or without initial values was developed. The resulting equation for the voltage across a capacitor is repeated below for convenience.

$$v_C = V_f + (V_i - V_f)e^{-t/RC} \quad (24.6)$$

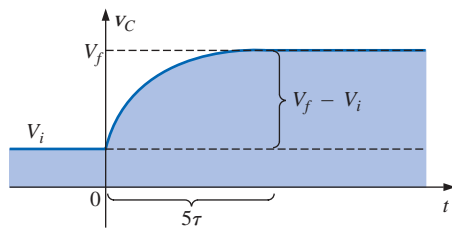


FIG. 24.18

Defining the parameters of Eq. (24.6).

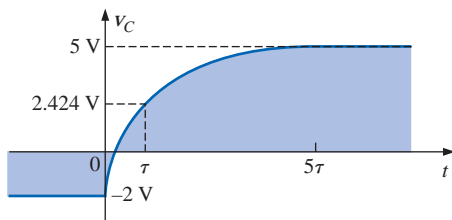


FIG. 24.19

Example of the use of Eq. (24.6).

Recall that  $V_i$  is the initial voltage across the capacitor when the transient phase is initiated as shown in Fig. 24.18. The voltage  $V_f$  is the steady-state (resting) value of the voltage across the capacitor when the transient phase has ended. The transient period is approximated as  $5\tau$ , where  $\tau$  is the time constant of the network and is equal to the product  $RC$ .

For the situation where the initial voltage is zero volts, the equation reduces to the following familiar form, where  $V_f$  is often the applied voltage:

$$v_C = V_f(1 - e^{-t/RC}) \quad V_i = 0 \text{ V} \quad (24.7)$$

For the case of Fig. 24.19,  $V_i = -2 \text{ V}$ ,  $V_f = +5 \text{ V}$ , and

$$\begin{aligned} v_C &= V_i + (V_f - V_i)(1 - e^{-t/RC}) \\ &= -2 \text{ V} + [5 \text{ V} - (-2 \text{ V})](1 - e^{-t/RC}) \\ v_C &= -2 \text{ V} + 7 \text{ V}(1 - e^{-t/RC}) \end{aligned}$$

For the case where  $t = \tau = RC$ ,

$$\begin{aligned} v_C &= -2 \text{ V} + 7 \text{ V}(1 - e^{-1}) = -2 \text{ V} + 7 \text{ V}(1 - e^{-1}) \\ &= -2 \text{ V} + 7 \text{ V}(1 - 0.368) = -2 \text{ V} + 7 \text{ V}(0.632) \\ v_C &= 2.424 \text{ V} \end{aligned}$$

as verified by Fig. 24.19.

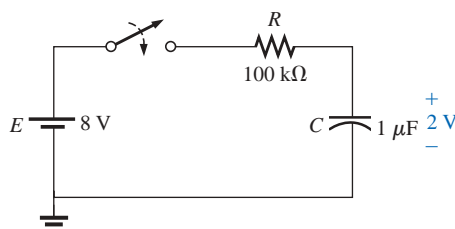


FIG. 24.20

Example 24.8.

**EXAMPLE 24.8** The capacitor of Fig. 24.20 is initially charged to 2 V before the switch is closed. The switch is then closed.

- Determine the mathematical expression for  $v_C$ .
- Determine the mathematical expression for  $i_C$ .
- Sketch the waveforms of  $v_C$  and  $i_C$ .

**Solutions:**

- $V_i = 2 \text{ V}$   
 $V_f$  (after  $5\tau$ ) =  $E = 8 \text{ V}$   
 $\tau = RC = (100 \text{ k}\Omega)(1 \mu\text{F}) = 100 \text{ ms}$

By Eq. (24.6),

$$\begin{aligned} v_C &= V_f + (V_i - V_f)e^{-t/RC} \\ &= 8 \text{ V} + (2 \text{ V} - 8 \text{ V})e^{-t/\tau} \end{aligned}$$

and

$$v_C = 8 \text{ V} - 6 \text{ V} e^{-t/\tau}$$



b. When the switch is first closed, the voltage across the capacitor cannot change instantaneously, and  $V_R = E - V_i = 8 \text{ V} - 2 \text{ V} = 6 \text{ V}$ . The current therefore jumps to a level determined by Ohm's law:

$$I_{R_{\max}} = \frac{V_R}{R} = \frac{6 \text{ V}}{100 \text{ k}\Omega} = 0.06 \text{ mA}$$

The current will then decay to zero amperes with the same time constant calculated in part (a), and

$$i_C = 0.06 \text{ mA} e^{-t/\tau}$$

c. See Fig. 24.21.

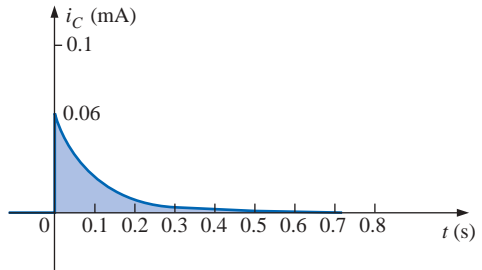
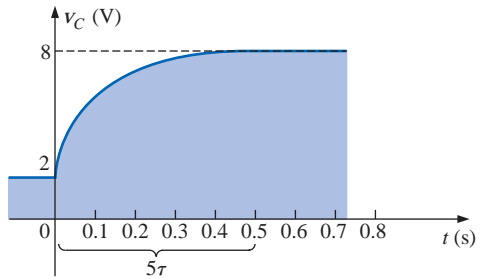


FIG. 24.21

$v_C$  and  $i_C$  for the network of Fig. 24.20.

**EXAMPLE 24.9** Sketch  $v_C$  for the step input shown in Fig. 24.22. Assume that the  $-4 \text{ mV}$  has been present for a period of time in excess of five time constants of the network. Then determine when  $v_C = 0 \text{ V}$  if the step changes levels at  $t = 0 \text{ s}$ .

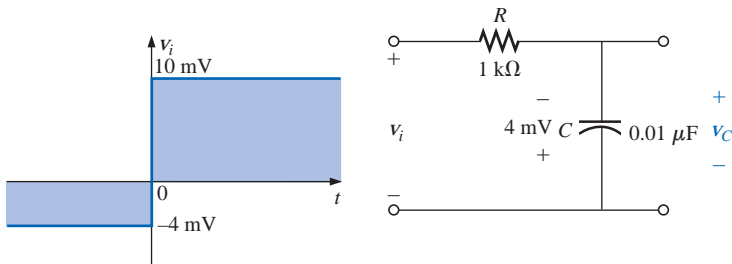


FIG. 24.22

Example 24.9.

**Solution:**

$$V_i = -4 \text{ mV} \quad V_f = 10 \text{ mV}$$

$$\tau = RC = (1 \text{ k}\Omega)(0.01 \text{ }\mu\text{F}) = 10 \text{ }\mu\text{s}$$

By Eq. (24.6),

$$v_C = V_f + (V_i - V_f)e^{-t/RC}$$

$$= 10 \text{ mV} + (-4 \text{ mV} - 10 \text{ mV})e^{-t/10\mu\text{s}}$$

and

$$v_C = 10 \text{ mV} - 14 \text{ mV} e^{-t/10\mu\text{s}}$$

The waveform appears in Fig. 24.23.

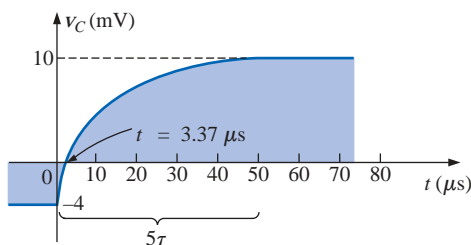


FIG. 24.23

$v_C$  for the network of Fig. 24.22.



Substituting  $v_C = 0 \text{ V}$  into the above equation yields

$$v_C = 0 \text{ V} = 10 \text{ mV} - 14 \text{ mV} e^{-t/10\mu\text{s}}$$

and 
$$\frac{10 \text{ mV}}{14 \text{ mV}} = e^{-t/10\mu\text{s}}$$

or 
$$0.714 = e^{-t/10\mu\text{s}}$$

but 
$$\log_e 0.714 = \log_e(e^{-t/10\mu\text{s}}) = \frac{-t}{10 \mu\text{s}}$$

and 
$$t = -(10 \mu\text{s})\log_e 0.714 = -(10 \mu\text{s})(-0.377) = 3.37 \mu\text{s}$$

as indicated in Fig. 24.23.

## 24.6 R-C RESPONSE TO SQUARE-WAVE INPUTS

The **square wave** of Fig. 24.24 is a particular form of pulse waveform. It has a duty cycle of 50% and an average value of zero volts, as calculated below:

$$\text{Duty cycle} = \frac{t_p}{T} \times 100\% = \frac{T/2}{T} \times 100\% = 50\%$$

$$V_{\text{av}} = \frac{(V_1)(T/2) + (-V_1)(T/2)}{T} = \frac{0}{T} = 0 \text{ V}$$

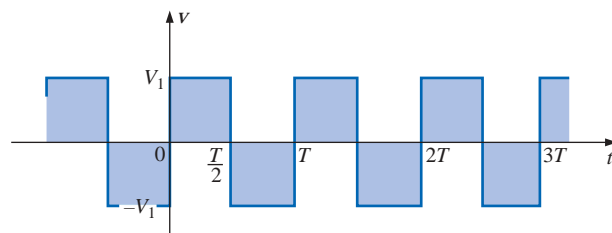


FIG. 24.24

Periodic square wave.

The application of a dc voltage  $V_1$  in series with the square wave of Fig. 24.24 can raise the base-line voltage from  $-V_1$  to zero volts and the average value to  $V_1$  volts.

If a square wave such as developed in Fig. 24.25 is applied to an

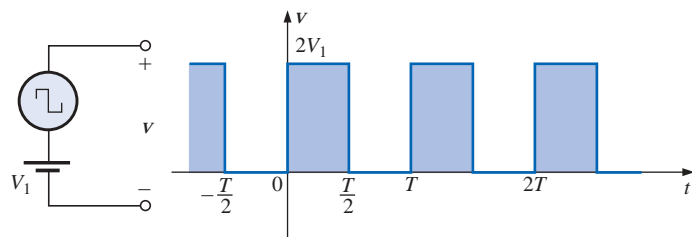


FIG. 24.25

Raising the base-line voltage of a square wave to zero volts.



R-C circuit as shown in Fig. 24.26, the period of the square wave can have a pronounced effect on the resulting waveform for  $v_C$ .

For the analysis to follow, we will assume that steady-state conditions will be established after a period of five time constants has passed. The types of waveforms developed across the capacitor can then be separated into three fundamental types:  $T/2 > 5\tau$ ,  $T/2 = 5\tau$ , and  $T/2 < 5\tau$ .

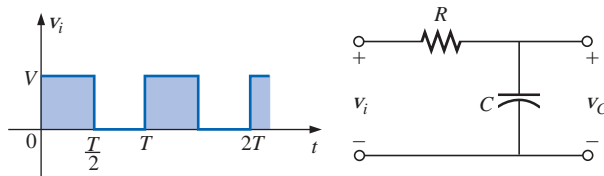


FIG. 24.26

Applying a periodic square-wave pulse train to an R-C network.

### $T/2 > 5\tau$

The condition  $T/2 > 5\tau$ , or  $T > 10\tau$ , establishes a situation where the capacitor can charge to its steady-state value in advance of  $t = T/2$ . The resulting waveforms for  $v_C$  and  $i_C$  will appear as shown in Fig. 24.27. Note how closely the voltage  $v_C$  shadows the applied waveform and how  $i_C$  is nothing more than a series of very sharp spikes. Note also that the change of  $V_i$  from  $V$  to zero volts during the trailing edge simply results in a rapid discharge of  $v_C$  to zero volts. In essence, when  $V_i = 0$ , the capacitor and resistor are in parallel and the capacitor simply discharges through  $R$  with a time constant equal to that encountered during the charging phase but with a direction of charge flow (current) opposite to that established during the charging phase.

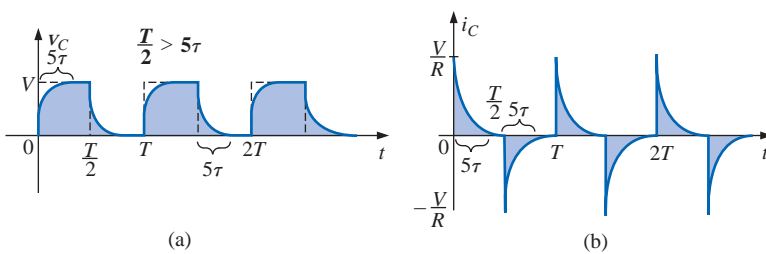
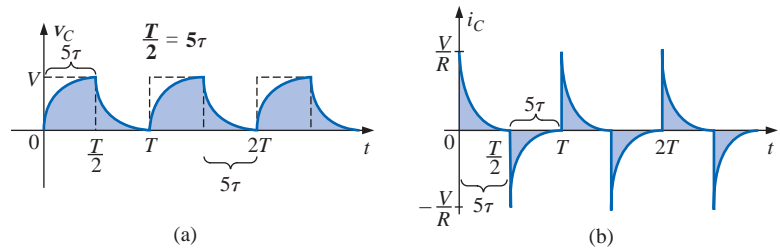


FIG. 24.27

$v_C$  and  $i_C$  for  $T/2 > 5\tau$ .

### $T/2 = 5\tau$

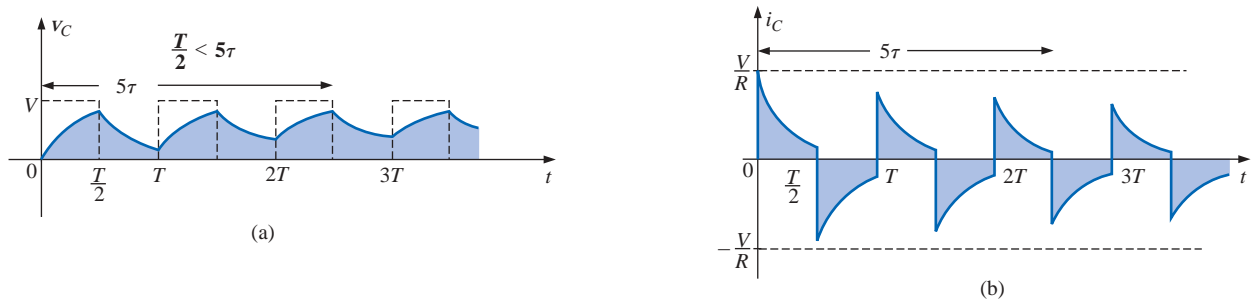
If the frequency of the square wave is chosen such that  $T/2 = 5\tau$  or  $T = 10\tau$ , the voltage  $v_C$  will reach its final value just before beginning its discharge phase, as shown in Fig. 24.28. The voltage  $v_C$  no longer resembles the square-wave input and, in fact, has some of the characteristics of a triangular waveform. The increased time constant has resulted in a more rounded  $v_C$ , and  $i_C$  has increased substantially in width to reveal the longer charging period.



**FIG. 24.28**  
 $v_C$  and  $i_C$  for  $T/2 = 5\tau$ .

**$T/2 < 5\tau$**

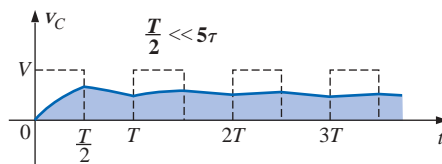
If  $T/2 < 5\tau$  or  $T < 10\tau$ , the voltage  $v_C$  will not reach its final value during the first pulse (Fig. 24.29), and the discharge cycle will not return to zero volts. In fact, the initial value for each succeeding pulse will change until steady-state conditions are reached. In most instances, it is a good approximation to assume that steady-state conditions have been established in five cycles of the applied waveform.



**FIG. 24.29**  
 $v_C$  and  $i_C$  for  $T/2 < 5\tau$ .

As the frequency increases and the period decreases, there will be a flattening of the response for  $v_C$  until a pattern like that in Fig. 24.30 results. Figure 24.30 begins to reveal an important conclusion regarding the response curve for  $v_C$ :

***Under steady-state conditions, the average value of  $v_C$  will equal the average value of the applied square wave.***



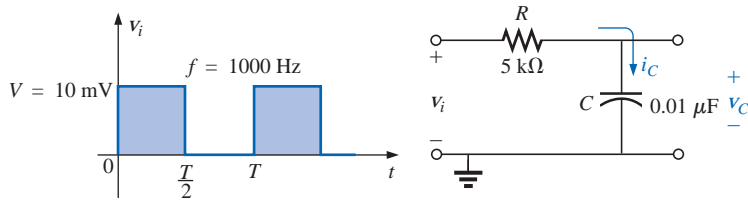
**FIG. 24.30**  
 $v_C$  for  $T/2 \ll 5\tau$  or  $T \ll 10\tau$ .



Note in Figs. 24.29 and 24.30 that the waveform for  $v_C$  approaches an average value of  $V/2$ .

**EXAMPLE 24.10** The 1000-Hz square wave of Fig. 24.31 is applied to the R-C circuit of the same figure.

- Compare the pulse width of the square wave to the time constant of the circuit.
- Sketch  $v_C$ .
- Sketch  $i_C$ .



**FIG. 24.31**  
Example 24.10.

**Solutions:**

a.  $T = \frac{1}{f} = \frac{1}{1000} = 1 \text{ ms}$

$t_p = \frac{T}{2} = 0.5 \text{ ms}$

$\tau = RC = (5 \times 10^3 \Omega)(0.01 \times 10^{-6} \text{ F}) = 0.05 \text{ ms}$

$\frac{t_p}{\tau} = \frac{0.5 \text{ ms}}{0.05 \text{ ms}} = 10$  and

$t_p = 10\tau = \frac{T}{2}$

The result reveals that  $v_C$  will charge to its final value in half the pulse width.

- b. For the charging phase,  $V_i = 0 \text{ V}$  and  $V_f = 10 \text{ mV}$ , and

$$v_C = V_f + (V_i - V_f)e^{-t/RC}$$

$$= 10 \text{ mV} + (0 - 10 \text{ mV})e^{-t/\tau}$$

and  $v_C = 10 \text{ mV}(1 - e^{-t/\tau})$

For the discharge phase,  $V_i = 10 \text{ mV}$  and  $V_f = 0 \text{ V}$ , and

$$v_C = V_f + (V_i - V_f)e^{-t/\tau}$$

$$= 0 \text{ V} + (10 \text{ mV} - 0 \text{ V})e^{-t/\tau}$$

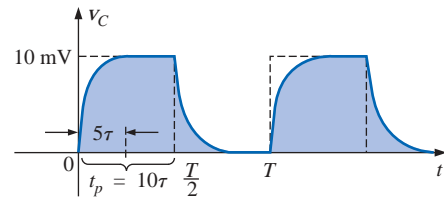
and  $v_C = 10 \text{ mV}e^{-t/\tau}$

The waveform for  $v_C$  appears in Fig. 24.32.

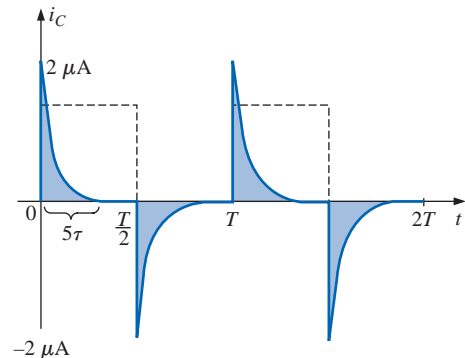
- c. For the charging phase at  $t = 0 \text{ s}$ ,  $V_R = V$  and  $I_{R_{\text{max}}} = V/R = 10 \text{ mV}/5 \text{ k}\Omega = 2 \mu\text{A}$ , and

$$i_C = I_{\text{max}}e^{-t/\tau} = 2 \mu\text{A}e^{-t/\tau}$$

For the discharge phase, the current will have the same mathematical formulation but the opposite direction, as shown in Fig. 24.33.



**FIG. 24.32**  
 $v_C$  for the R-C network of Fig. 24.31.



**FIG. 24.33**  
 $i_C$  for the R-C network of Fig. 24.31.



**EXAMPLE 24.11** Repeat Example 24.10 for  $f = 10$  kHz.

**Solution:**

$$T = \frac{1}{f} = \frac{1}{10 \text{ kHz}} = 0.1 \text{ ms}$$

and 
$$\frac{T}{2} = 0.05 \text{ ms}$$

with 
$$\tau = t_p = \frac{T}{2} = 0.05 \text{ ms}$$

In other words, the pulse width is exactly equal to the time constant of the network. The voltage  $v_C$  will not reach the final value before the first pulse of the square-wave input returns to zero volts.

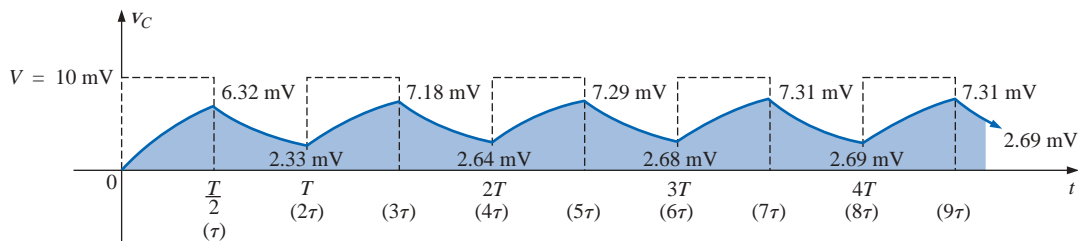
For  $t$  in the range  $t = 0$  to  $T/2$ ,  $V_i = 0$  V and  $V_f = 10$  mV, and

$$v_C = 10 \text{ mV}(1 - e^{-t/\tau})$$

We recall from Chapter 10 that at  $t = \tau$ ,  $v_C = 63.2\%$  of the final value. Substituting  $t = \tau$  into the equation above yields

$$\begin{aligned} v_C &= (10 \text{ mV})(1 - e^{-1}) = (10 \text{ mV})(1 - 0.368) \\ &= (10 \text{ mV})(0.632) = 6.32 \text{ mV} \end{aligned}$$

as shown in Fig. 24.34.



**FIG. 24.34**

$v_C$  response for  $t_p = \tau = T/2$ .

For the discharge phase between  $t = T/2$  and  $T$ ,  $V_i = 6.32$  mV and  $V_f = 0$  V, and

$$\begin{aligned} v_C &= V_f + (V_i - V_f)e^{-t/\tau} \\ &= 0 \text{ V} + (6.32 \text{ mV} - 0 \text{ V})e^{-t/\tau} \\ v_C &= 6.32 \text{ mV}e^{-t/\tau} \end{aligned}$$

with  $t$  now being measured from  $t = T/2$  in Fig. 24.34. In other words, for each interval of Fig. 24.34, the beginning of the transient waveform is defined as  $t = 0$  s. The value of  $v_C$  at  $t = T$  is therefore determined by substituting  $t = \tau$  into the above equation, and not  $2\tau$  as defined by Fig. 24.34.

Substituting  $t = \tau$ ,

$$\begin{aligned} v_C &= (6.32 \text{ mV})(e^{-1}) = (6.32 \text{ mV})(0.368) \\ &= 2.33 \text{ mV} \end{aligned}$$

as shown in Fig. 24.34.



For the next interval,  $V_i = 2.33 \text{ mV}$  and  $V_f = 10 \text{ mV}$ , and

$$\begin{aligned} v_C &= V_f + (V_i - V_f)e^{-t/\tau} \\ &= 10 \text{ mV} + (2.33 \text{ mV} - 10 \text{ mV})e^{-t/\tau} \\ v_C &= 10 \text{ mV} - 7.67 \text{ mV} e^{-t/\tau} \end{aligned}$$

At  $t = \tau$  (since  $t = T = 2\tau$  is now  $t = 0 \text{ s}$  for this interval),

$$\begin{aligned} v_C &= 10 \text{ mV} - 7.67 \text{ mV}e^{-1} \\ &= 10 \text{ mV} - 2.82 \text{ mV} \\ v_C &= 7.18 \text{ mV} \end{aligned}$$

as shown in Fig. 24.34.

For the discharge interval,  $V_i = 7.18 \text{ mV}$  and  $V_f = 0 \text{ V}$ , and

$$\begin{aligned} v_C &= V_f + (V_i - V_f)e^{-t/\tau} \\ &= 0 \text{ V} + (7.18 \text{ mV} - 0)e^{-t/\tau} \\ v_C &= 7.18 \text{ mV}e^{-t/\tau} \end{aligned}$$

At  $t = \tau$  (measured from  $3\tau$  of Fig. 24.34),

$$\begin{aligned} v_C &= (7.18 \text{ mV})(e^{-1}) = (7.18 \text{ mV})(0.368) \\ &= 2.64 \text{ mV} \end{aligned}$$

as shown in Fig. 24.34.

Continuing in the same manner, the remaining waveform for  $v_C$  will be generated as depicted in Fig. 24.34. Note that repetition occurs after  $t = 8\tau$ , and the waveform has essentially reached steady-state conditions in a period of time less than  $10\tau$ , or five cycles of the applied square wave.

A closer look will reveal that both the peak and the lower levels continued to increase until steady-state conditions were established. Since the exponential waveforms between  $t = 4T$  and  $t = 5T$  have the same time constant, the average value of  $v_C$  can be determined from the steady-state 7.31-mV and 2.69-mV levels as follows:

$$V_{\text{av}} = \frac{7.31 \text{ mV} + 2.69 \text{ mV}}{2} = \frac{10 \text{ mV}}{2} = 5 \text{ mV}$$

which equals the average value of the applied signal as stated earlier in this section.

We can use the results of Fig. 24.34 to plot  $i_C$ . At any instant of time,

$$v_i = v_R + v_C \quad \text{or} \quad v_R = v_i - v_C$$

and 
$$i_R = i_C = \frac{v_i - v_C}{R}$$

At  $t = 0^+$ ,  $v_C = 0 \text{ V}$ , and

$$i_R = \frac{v_i - v_C}{R} = \frac{10 \text{ mV} - 0}{5 \text{ k}\Omega} = 2 \mu\text{A}$$

as shown in Fig. 24.35.

As the charging process proceeds, the current  $i_C$  will decay at a rate determined by

$$i_C = 2 \mu\text{A}e^{-t/\tau}$$

At  $t = \tau$ ,

$$\begin{aligned} i_C &= (2 \mu\text{A})(e^{-\tau/\tau}) = (2 \mu\text{A})(e^{-1}) = (2 \mu\text{A})(0.368) \\ &= 0.736 \mu\text{A} \end{aligned}$$

as shown in Fig. 24.35.

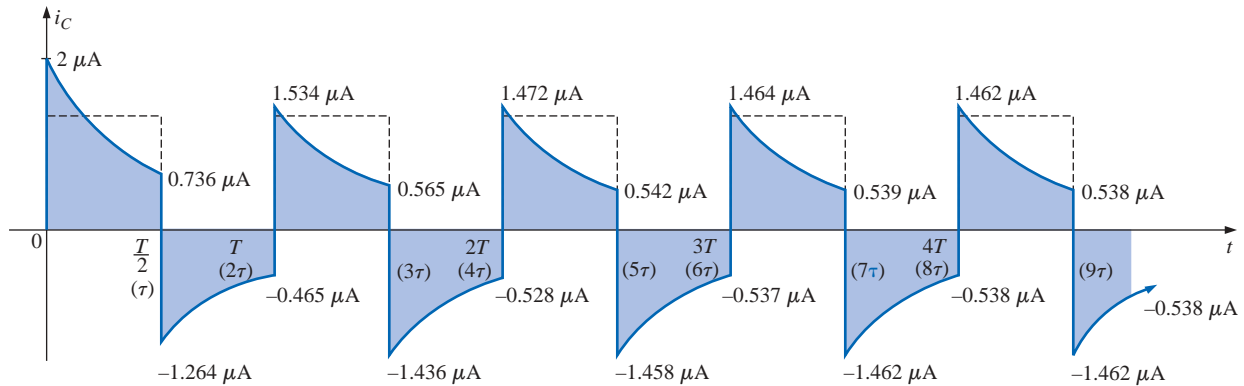


FIG. 24.35

$i_C$  response for  $t_p = \tau = T/2$ .

For the trailing edge of the first pulse, the voltage across the capacitor cannot change instantaneously, resulting in the following when  $v_i$  drops to zero volts:

$$i_C = i_R = \frac{v_i - v_C}{R} = \frac{0 - 6.32 \text{ mV}}{5 \text{ k}\Omega} = -1.264 \mu\text{A}$$

as illustrated in Fig. 24.35. The current will then decay as determined by

$$i_C = -1.264 \mu\text{A} e^{-t/\tau}$$

and at  $t = \tau$  (actually  $t = 2\tau$  in Fig. 24.35),

$$\begin{aligned} i_C &= (-1.264 \mu\text{A})(e^{-\tau/\tau}) = (-1.264 \mu\text{A})(e^{-1}) \\ &= (-1.264 \mu\text{A})(0.368) = -0.465 \mu\text{A} \end{aligned}$$

as shown in Fig. 24.35.

At  $t = T$  ( $t = 2\tau$ ),  $v_C = 2.33 \text{ mV}$ , and  $v_i$  returns to  $10 \text{ mV}$ , resulting in

$$i_C = i_R = \frac{v_i - v_C}{R} = \frac{10 \text{ mV} - 2.33 \text{ mV}}{5 \text{ k}\Omega} = 1.534 \mu\text{A}$$

The equation for the decaying current is now

$$i_C = 1.534 \mu\text{A} e^{-t/\tau}$$

and at  $t = \tau$  (actually  $t = 3\tau$  in Fig. 24.35),

$$i_C = (1.534 \mu\text{A})(0.368) = 0.565 \mu\text{A}$$

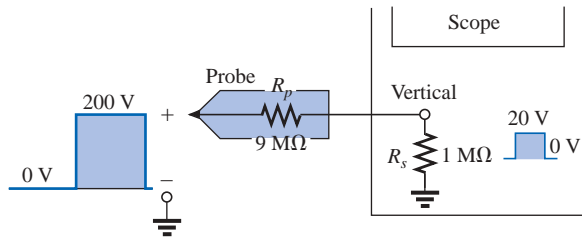
The process will continue until steady-state conditions are reached at the same time they were attained for  $v_C$ . Note in Fig. 24.35 that the positive peak current decreased toward steady-state conditions while the negative peak became more negative. It is also interesting and important to realize that the current waveform becomes symmetrical about the axis when steady-state conditions are established. The result is that the net average current over one cycle is zero, as it should be in a series  $R$ - $C$  circuit. Recall from Chapter 10 that the capacitor under dc steady-state conditions can be replaced by an open-circuit equivalent, resulting in  $I_C = 0 \text{ A}$ .



Although both examples provided above started with an uncharged capacitor, there is no reason that the same approach cannot be used effectively for initial conditions. Simply substitute the initial voltage on the capacitor as  $V_i$  in Eq. (24.6) and proceed as above.

### 24.7 OSCILLOSCOPE ATTENUATOR AND COMPENSATING PROBE

The  $\times 10$  **attenuator probe** employed with oscilloscopes is designed to reduce the magnitude of the input voltage by a factor of 10. If the input impedance to a scope is  $1\text{ M}\Omega$ , the  $\times 10$  attenuator probe will have an internal resistance of  $9\text{ M}\Omega$ , as shown in Fig. 24.36.

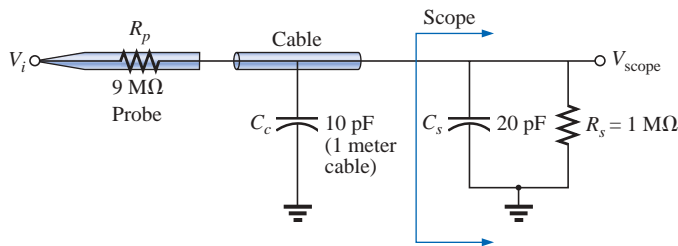


**FIG. 24.36**  
 $\times 10$  attenuator probe.

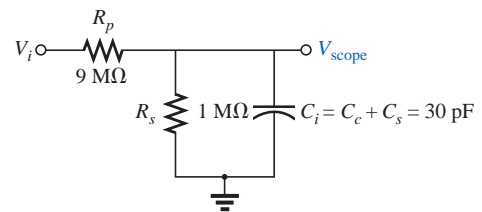
Applying the voltage divider rule,

$$V_{\text{scope}} = \frac{(1\text{ M}\Omega)(V_i)}{1\text{ M}\Omega + 9\text{ M}\Omega} = \frac{1}{10}V_i$$

In addition to the input resistance, oscilloscopes have some internal input capacitance, and the probe will add an additional capacitance in parallel with the oscilloscope capacitance, as shown in Fig. 24.37. The probe capacitance is typically about  $10\text{ pF}$  for a 1-m (3.3-ft) cable, reaching about  $15\text{ pF}$  for a 3-m (9.9-ft) cable. The total input capacitance is therefore the sum of the two capacitive elements, resulting in the equivalent network of Fig. 24.38.



**FIG. 24.37**  
Capacitive elements present in an attenuator probe arrangement.



**FIG. 24.38**  
Equivalent network of Fig. 24.37.

For the analysis to follow, let us determine the Thévenin equivalent circuit for the capacitor  $C_i$ :

$$E_{Th} = \frac{(1\text{ M}\Omega)(V_i)}{1\text{ M}\Omega + 9\text{ M}\Omega} = \frac{1}{10}V_i$$

and

$$R_{Th} = 9\text{ M}\Omega \parallel 1\text{ M}\Omega = 0.9\text{ M}\Omega$$

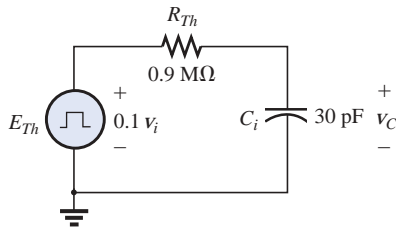


FIG. 24.39

Thévenin equivalent for  $C_i$  of Fig. 24.38.

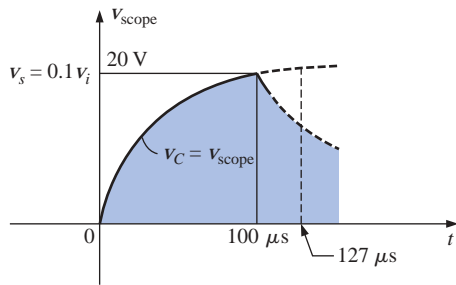


FIG. 24.40

The scope pattern for the conditions of Fig. 24.38 with  $v_i = 200$  V peak.



FIG. 24.41

Commercial compensated 10:1 attenuator probe. (Courtesy of Tektronix, Inc.)

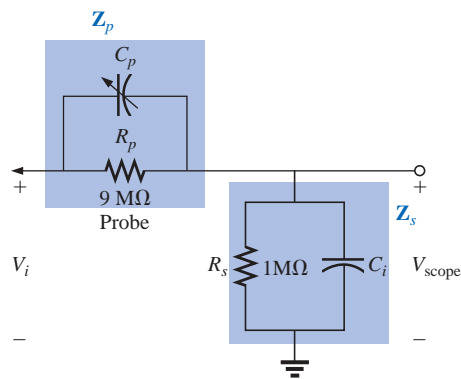


FIG. 24.42

Compensated attenuator and input impedance to a scope, including the cable capacitance.

The Thévenin network is shown in Fig. 24.39.

For  $v_i = 200$  V (peak),

$$E_{Th} = 0.1 v_i = 20 \text{ V (peak)}$$

and for  $v_C$ ,  $V_f = 20$  V and  $V_i = 0$  V, with

$$\tau = RC = (0.9 \times 10^6 \Omega)(30 \times 10^{-12} \text{ F}) = 27 \mu\text{s}$$

For an applied frequency of 5 kHz,

$$T = \frac{1}{f} = 0.2 \text{ ms} \quad \text{and} \quad \frac{T}{2} = 0.1 \text{ ms} = 100 \mu\text{s}$$

with  $5\tau = 135 \mu\text{s} > 100 \mu\text{s}$ , as shown in Fig. 24.40, clearly producing a severe rounding distortion of the square wave and a poor representation of the applied signal.

To improve matters, a variable capacitor is often added in parallel with the resistance of the attenuator, resulting in a **compensated attenuator probe** such as the one shown in Fig. 24.41. In Chapter 21, it was demonstrated that a square wave can be generated by a summation of sinusoidal signals of particular frequency and amplitude. If we therefore design a network such as the one shown in Fig. 24.42 that will ensure that  $V_{\text{scope}}$  is  $0.1 v_i$  for any frequency, then the rounding distortion will be removed, and  $V_{\text{scope}}$  will have the same appearance as  $v_i$ .

Applying the voltage divider rule to the network of Fig. 24.42,

$$V_{\text{scope}} = \frac{Z_s V_i}{Z_s + Z_p} \tag{24.8}$$

If the parameters are chosen or adjusted such that

$$R_p C_p = R_s C_s \tag{24.9}$$

the phase angle of  $Z_s$  and  $Z_p$  will be the same, and Equation (24.8) will reduce to

$$V_{\text{scope}} = \frac{R_s V_i}{R_s + R_p} \tag{24.10}$$

which is insensitive to frequency since the capacitive elements have dropped out of the relationship.

In the laboratory, simply adjust the probe capacitance using a standard or known square-wave signal until the desired sharp corners of the square wave are obtained. If you avoid the calibration step, you may make a rounded signal look square since you assumed a square wave at the point of measurement.

Too much capacitance will result in an overshoot effect, whereas too little will continue to show the rounding effect.

## 24.8 APPLICATION

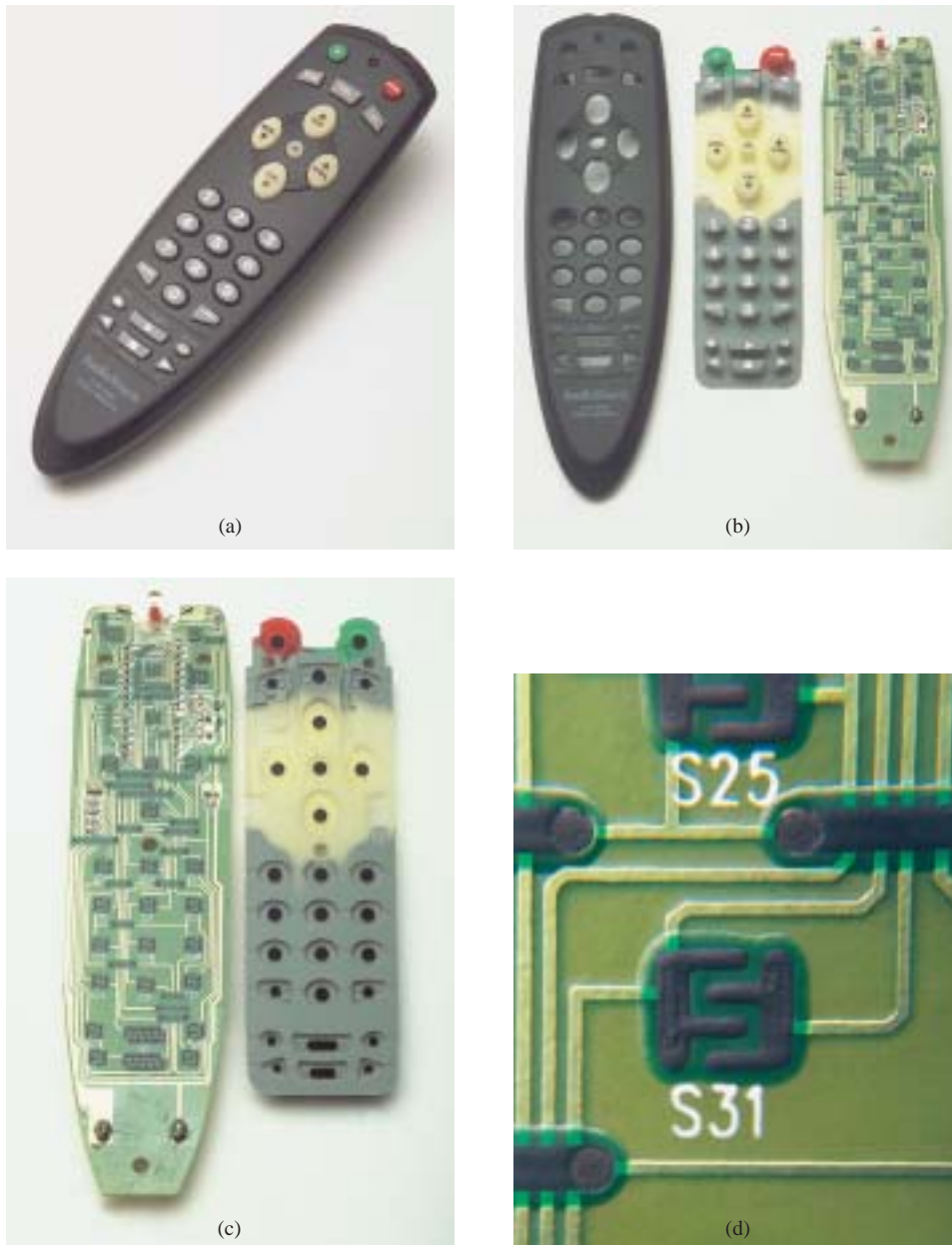
### TV Remote

The TV remote, or “clicker,” is so much a part of our modern-day living that we must all have wondered at one time or another how it looks inside or how it works. In many ways it is similar to the garage door



opener or the car alarm transmitter in that there is no visible connection between the transmitter and the receiver, and each transmitter is linked to its receiver with a special code. The only major difference between the TV remote and the other controls is that the TV remote uses an infrared frequency while the other two use a much lower radio frequency.

The TV remote of Fig. 24.43(a) has been opened to reveal the internal construction of its key pad and face in Fig. 24.43(b). The three components of Fig. 24.43(b) were placed at a level that would permit matching the holes in the cover with the actual keys in the switch membrane and with the location that each button on the key pad would hit on face of the printed circuit board. Note on the printed circuit board that there



**FIG. 24.43**

*TV remote: (a) external appearance; (b) internal construction; (c) carbon key pads; (d) enlarged view of S31 key pad.*

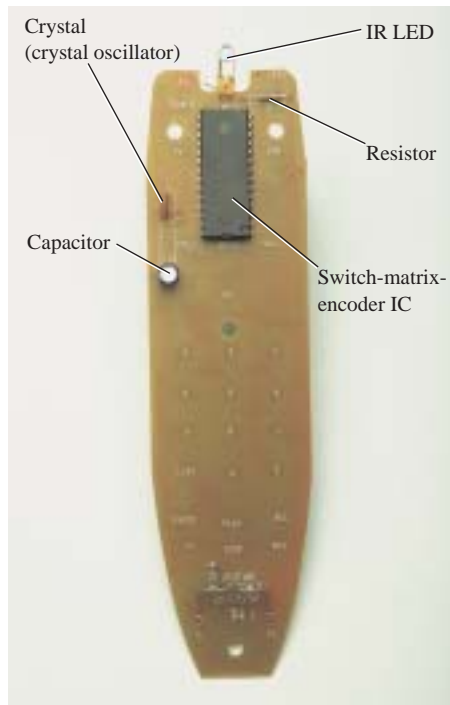


FIG. 24.44

Back side of TV remote of Fig. 24.43.

is a black pad to match each key on the membrane. The back side of the switch membrane is shown in Fig. 24.43(c) to show the soft carbon contacts that will make contact with the carbon contacts on the printed board when the buttons are depressed. An enlarged view of one of the contacts (S31) of Fig. 24.43(c) is shown in Fig. 24.43(d) to illustrate the separation between circuits and the pattern used to ensure continuity when the solid round carbon pad at the bottom of the key is put in place.

All the connections established when a key is pressed are passed on to a relatively large switch-matrix-encoder IC chip appearing on the back side of the printed circuit board as shown in Fig. 24.44. For the pad (S31) of Fig. 24.43(d), three wires of the matrix appearing in Fig. 24.43(b) will be connected when the corresponding key (number 5) is pressed. The encoder will then react to this combination and send out the appropriate signal as an infrared (IR) signal from the IR LED appearing at the end of the remote control, as shown in Fig. 24.43(b) and Fig. 24.44. The second smaller LED (red on actual unit) appearing at the top of Fig. 24.43(b) blinks during transmission. Once the batteries are inserted, the CMOS electronic circuitry that controls the operation of the remote is *always on*. This is possible only because of the very low power drain of CMOS circuitry. The power (PWR) button is used only to turn the TV on and activate the receiver.

The signal sent out by the majority of remotes is one of the two types appearing in Fig. 24.45. In each case there is a *key pulse* to initiate the signal sequence and to inform the receiver that the coded signal is about to arrive. In Fig. 24.45(a), a 4-bit binary-coded signal is transmitted using pulses in specific locations to represent the “ones” and using the absence of a pulse to represent the “zeros.” That coded signal can then be interpreted by the receiver unit and the proper operation performed. In Fig. 24.45(b), the signal is frequency controlled. Each key will have a different frequency associated with it. The result is that each key will have a specific transmission frequency. Since each TV receiver will respond to a different pulse train, a remote must be coded for the TV under control. There are *fixed program* remotes that can be used with

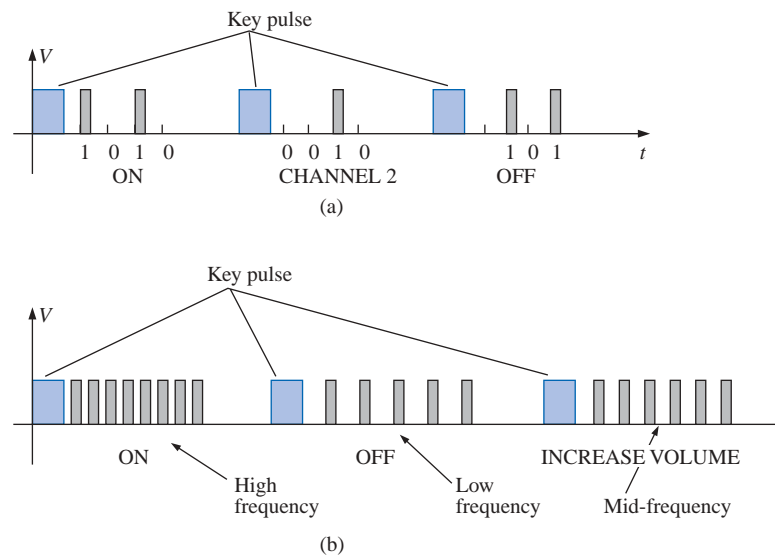
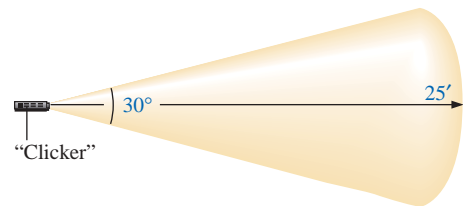


FIG. 24.45

Signal transmission: (a) pulse train; (b) variation.

only one TV. Then there are *smart* remotes that are preprogrammed internally with a number of remote control codes. Remotes of this type simply need to be told which TV is involved using a three-digit coding system, and they will adapt accordingly. *Learning* remotes are those that can use the old remote to learn the code and then store it for future use. In this case, one remote is set directly in front of the other, and the information is transferred from one to the other when both are energized. Remotes are also available that are a combination of the last two.

The remote of Fig. 24.43 uses four AAA batteries in series for a total of 6 V. It has its own local crystal oscillator separate from the IC as shown by the discrete elements to the top right and midleft of the printed circuit board of Fig. 24.43(c). The crystal itself, which is relatively large compared to the other elements, appears on the other side of the board just above the electrolytic capacitor in Fig. 24.44. It is the responsibility of the oscillator to generate the pulse signal required for proper IC operation. Note how flush most of the discrete elements are in Fig. 24.43(b), and note the rather large electrolytic capacitor on the back of the printed circuit board in Fig. 24.44. The specifications on the unit give it a range control of 25 ft with a 30° coverage arc as shown in Fig. 24.46. The arc coverage of your unit can easily be tested by simply pointing it directly at the TV and then moving it in any direction until it no longer controls the TV.



**FIG. 24.46**  
Range and coverage arc for TV remote of Fig. 24.43.

## 24.9 COMPUTER ANALYSIS

### PSpice

**R-C Response** Our analysis will begin with a verification of the results of Example 24.10 which examined the response of the series *R-C* circuit appearing on the schematic of Fig. 24.47. The source is one used in Chapters 10 and 12 to replicate the action of a switch in series with a dc source. The defining attributes for the pulse waveform are repeated for convenience in Fig. 24.48. Recall that the **PW** was made long enough so that the full transient period could be examined. In this analysis the pulse width will be adjusted to permit viewing the transient behavior of an *R-C* network between changing levels of the applied pulse. Initially the **PW** will be set at 10 times the time constant of the network so that the full transient response can occur between changes in voltage level. The time constant of the network is  $\tau = RC = (5 \text{ k}\Omega)(0.01 \text{ }\mu\text{F}) = 0.05 \text{ ms}$ , resulting in a **PW** of 0.5 ms in Fig. 24.47. To establish a square-wave appearance, the period was chosen as twice the pulse width or 1 ms as shown in the **VPulse** listing.

In the **Simulation Settings** dialog box, **Time Domain(Transient)** is selected because we want a response versus time. The **Run to time** is selected as 2 ms so that two full cycles will result. The **Start saving data after** was left on the default value of 0 s, and the **Maximum step size** was set at  $2 \text{ ms}/1000 = 2 \text{ }\mu\text{s}$ . After simulation, **Trace-Add Trace-I(C)-OK**, the bottom plot of Fig. 24.49 was the result. Note that the maximum current is  $2 \text{ }\mu\text{A}$  as determined by  $I_{C_{\max}} = 10 \text{ mV}/5 \text{ k}\Omega$ , and the full transient response appears within each pulse. Note also that the current dropped below the axis to reveal a change in direction when the applied voltage dropped from the 10-mV level to 0 V. Through **Plot-Add Plot to Window-Trace-Add Trace-V(Vpulse: +)-OK-Trace-Add Trace-V(C:1)-OK**, the plots of the applied voltage and the voltage across the capacitor can be displayed in the upper graph of Fig. 24.49.

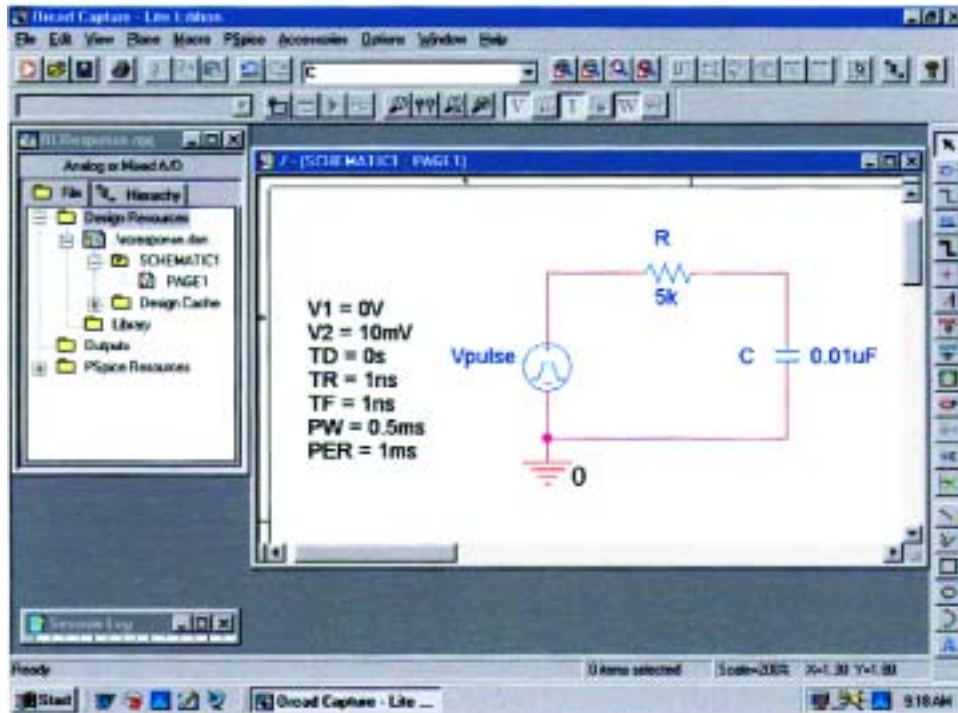


FIG. 24.47

Using PSpice to verify the results of Example 24.10.

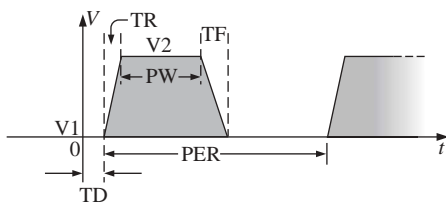


FIG. 24.48

Defining the PSpice *Vpulse* parameters.

First we select the upper graph of Fig. 24.49 to which to move the **SEL>>**, and then we select the **Toggle cursor** key. Now we can left-click on **V(C:1)** at the bottom right of the graph and set a cursor on the graph with a left click of the mouse. Setting the cursor at five time constants reveals that the transient voltage has reached 9.935 mV. Setting the right-click cursor at ten time constants reveals that  $V_C$  has essentially reached the 10-mV level.

**Setting  $t_p = \tau = T/2$**  The parameters of the source will now be modified by changing the frequency of the pulse waveform to 10 kHz with a period of 0.1 ms and a pulse width of 0.05 ms. For **Vpulse** the changes are **PW = 0.05 ms** and **PER = 0.1 ms**. The time constant of the network remains the same at 0.05 ms, so we have a situation where the pulse width equals the time constant of the circuit. The result is that it will take a number of pulses before the voltage across the capacitor will reach its final value of 10 mV. Under the **Simulation Settings**, the **Run to time** will be changed to 0.5 ms = 500  $\mu$ s or five cycles of the applied voltage. The **Maximum step size** will be changed to 500  $\mu$ s/1000 = 500 ns = 0.5  $\mu$ s. Under the **SCHEMATIC1** window, **Trace-Add Trace-V(C:1)-OK** is selected to obtain the transient voltage across the capacitor, while **Trace-Add Trace-V(Vpulse: +)-OK** will place the applied voltage on the same screen. Note in the resulting plots of Fig. 24.50 that the voltage builds up from 0 V until it appears to reach a fairly steady state after 400  $\mu$ s. At 400  $\mu$ s, a left cursor (**A1**) was used to find the minimum point with 2.71 mV resulting—a close match with the longhand calculation of Example 24.11 at 2.69 mV. At 450  $\mu$ s, the right-click cursor (**A2**) provided a level of 7.29 mV which is again a close match with the calculated level of 7.31 mV.

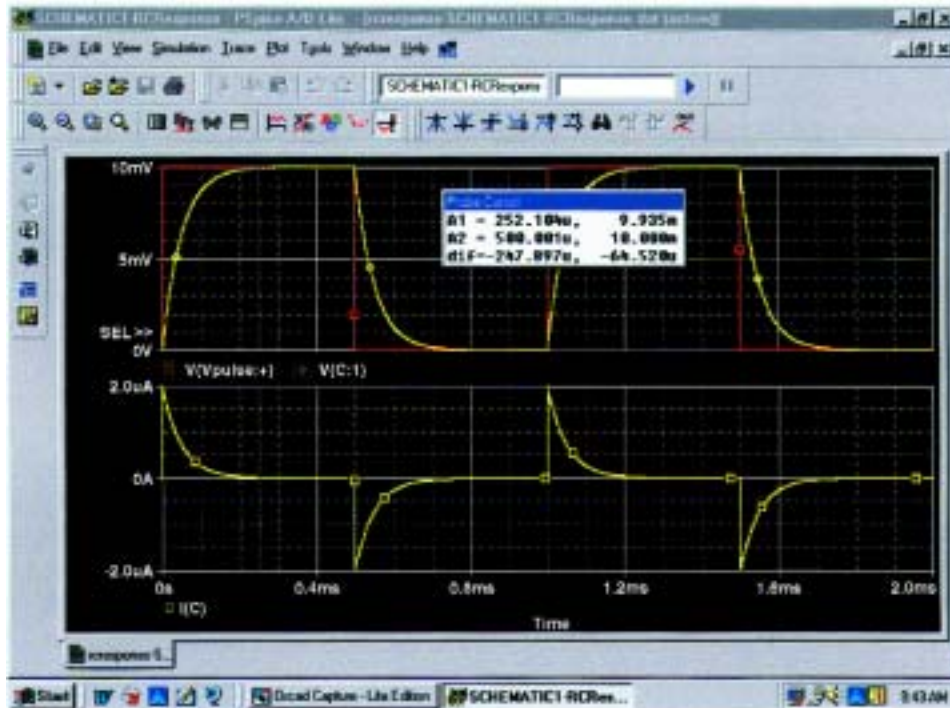


FIG. 24.49

Plot of  $v_{pulse}$ ,  $v_C$ , and  $i_C$  for the circuit of Fig. 24.47.

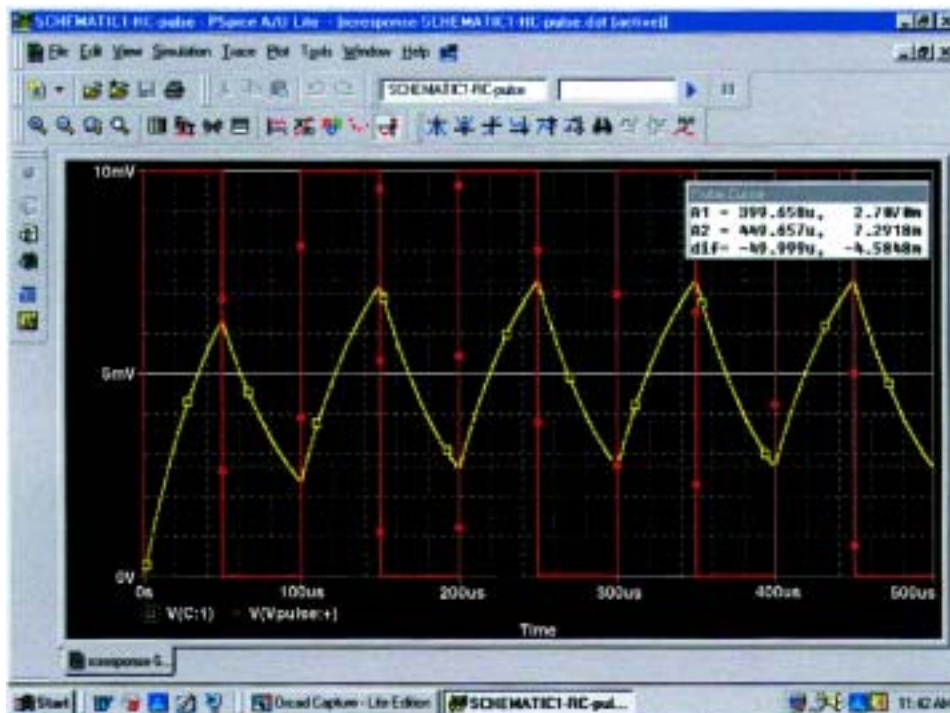


FIG. 24.50

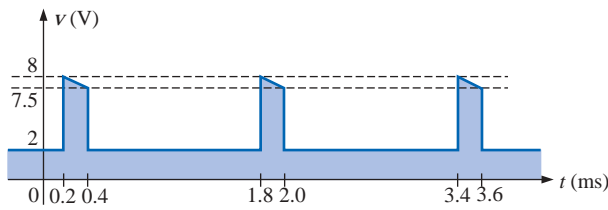
Plot of  $v_C$  for the circuit of Fig. 24.47 with  $t_p = \tau = T/2$ .



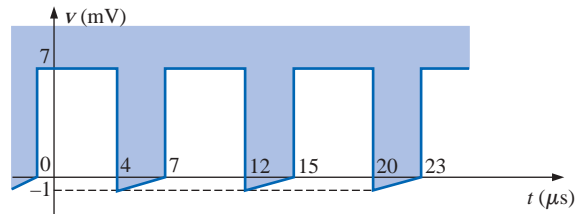
## PROBLEMS

### SECTION 24.2 Ideal versus Actual

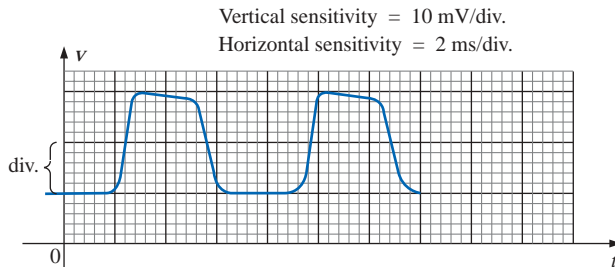
- Determine the following for the pulse waveform of Fig. 24.51:
  - positive- or negative-going?
  - base-line voltage
  - pulse width
  - amplitude
  - % tilt
- Repeat Problem 1 for the pulse waveform of Fig. 24.52.



**FIG. 24.51**  
Problems 1, 8, and 12.

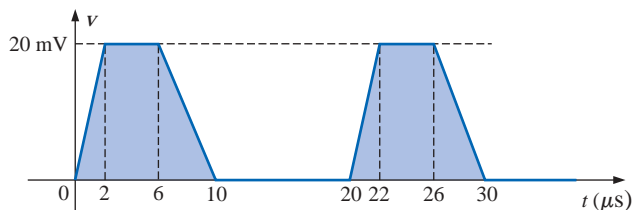


**FIG. 24.52**  
Problems 2 and 9.

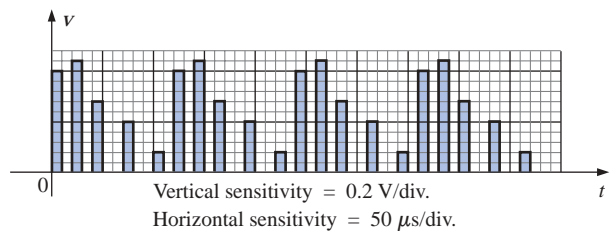


**FIG. 24.53**  
Problems 3, 4, 10, and 13.

- Repeat Problem 1 for the pulse waveform of Fig. 24.53.
- Determine the rise and fall times for the waveform of Fig. 24.53.
- Sketch a pulse waveform that has a base-line voltage of  $-5$  mV, a pulse width of  $2 \mu\text{s}$ , an amplitude of  $15$  mV, a 10% tilt, a period of  $10 \mu\text{s}$ , and vertical sides, and that is positive-going.
- For the waveform of Fig. 24.54, established by straight-line approximations of the original waveform:
  - Determine the rise time.
  - Find the fall time.
  - Find the pulse width.
  - Calculate the frequency.
- For the waveform of Fig. 24.55:
  - Determine the period.
  - Find the frequency.
  - Find the maximum and minimum amplitudes.



**FIG. 24.54**  
Problems 6 and 14.



**FIG. 24.55**  
Problems 7 and 15.

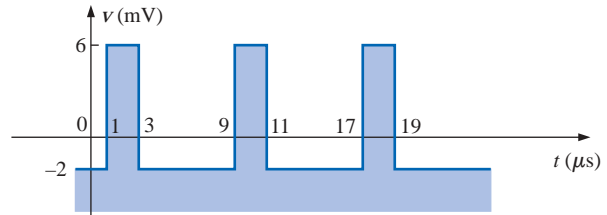


### SECTION 24.3 Pulse Repetition Rate and Duty Cycle

8. Determine the pulse repetition frequency and duty cycle for the waveform of Fig. 24.51.
9. Determine the pulse repetition frequency and duty cycle for the waveform of Fig. 24.52.
10. Determine the pulse repetition frequency and duty cycle for the waveform of Fig. 24.53.

### SECTION 24.4 Average Value

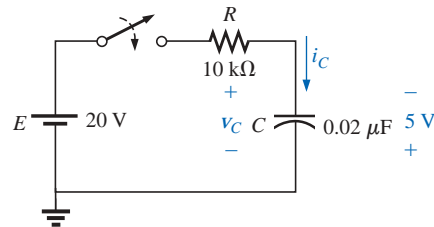
11. For the waveform of Fig. 24.56, determine the
  - a. period.
  - b. pulse width.
  - c. pulse repetition frequency.
  - d. average value.
  - e. effective value.
12. Determine the average value of the periodic pulse waveform of Fig. 24.51.
13. To the best accuracy possible, determine the average value of the waveform of Fig. 24.53.
14. Determine the average value of the waveform of Fig. 24.54.
15. Determine the average value of the periodic pulse train of Fig. 24.55.



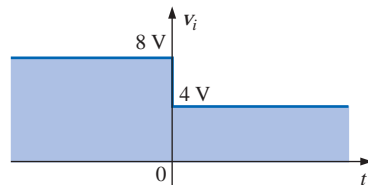
**FIG. 24.56**  
Problem 11.

### SECTION 24.5 Transient R-C Networks

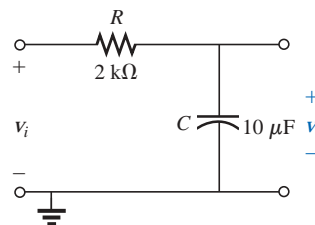
16. The capacitor of Fig. 24.57 is initially charged to 5 V, with the polarity indicated in the figure. The switch is then closed at  $t = 0$  s.
  - a. What is the mathematical expression for the voltage  $v_C$ ?
  - b. Sketch  $v_C$  versus  $t$ .
  - c. What is the mathematical expression for the current  $i_C$ ?
  - d. Sketch  $i_C$  versus  $t$ .
17. For the input voltage  $v_i$  appearing in Fig. 24.58, sketch the waveform for  $v_o$ . Assume that steady-state conditions were established with  $v_i = 8$  V.



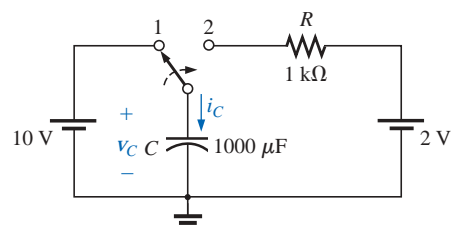
**FIG. 24.57**  
Problem 16.



**FIG. 24.58**  
Problem 17.



18. The switch of Fig. 24.59 is in position 1 until steady-state conditions are established. Then the switch is moved (at  $t = 0$  s) to position 2. Sketch the waveform for the voltage  $v_C$ .
19. Sketch the waveform for  $i_C$  for Problem 18.



**FIG. 24.59**  
Problems 18 and 19.



### SECTION 24.6 R-C Response to Square-Wave Inputs

20. Sketch the voltage  $v_C$  for the network of Fig. 24.60 due to the square-wave input of the same figure with a frequency of
- 500 Hz.
  - 100 Hz.
  - 5000 Hz.

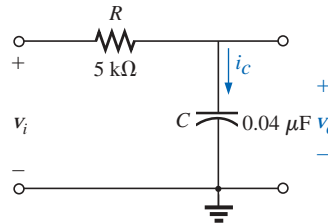
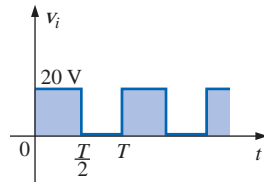


FIG. 24.60

Problems 20, 21, 23, 24, 27, and 28.

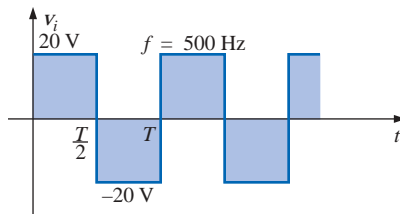


FIG. 24.61  
Problem 22.

- Sketch the current  $i_C$  for each frequency of Problem 20.
- Sketch the response  $v_C$  of the network of Fig. 24.60 to the square-wave input of Fig. 24.61.
- If the capacitor of Fig. 24.60 is initially charged to 20 V, sketch the response  $v_C$  to the same input signal (of Fig. 24.60) at a frequency of 500 Hz.
- Repeat Problem 23 if the capacitor is initially charged to  $-10$  V.

### SECTION 24.7 Oscilloscope Attenuator and Compensating Probe

- Given the network of Fig. 24.42 with  $R_p = 9$  MΩ and  $R_s = 1$  MΩ, find  $\mathbf{V}_{\text{scope}}$  in polar form if  $C_p = 3$  pF,  $C_s = 18$  pF,  $C_c = 9$  pF, and  $v_i = \sqrt{2}(100) \sin 2\pi 10,000t$ . That is, determine  $\mathbf{Z}_s$  and  $\mathbf{Z}_p$ , substitute into Eq. (24.8), and compare the results obtained with Eq. (24.10). Is it verified that the phase angle of  $\mathbf{Z}_s$  and  $\mathbf{Z}_p$  is the same under the condition  $R_p C_p = R_s C_s$ ?
- Repeat Problem 25 at  $\omega = 10^5$  rad/s.

### SECTION 24.9 Computer Analysis

#### Spice or Electronics Workbench

- Using schematics, obtain the waveforms for  $v_C$  and  $i_C$  for the network of Fig. 24.60 for a frequency of 1 kHz.
- Using schematics, place the waveforms of  $v_i$ ,  $v_C$ , and  $i_C$  on the same printout for the network of Fig. 24.60 at a frequency of 2 kHz.
- Using schematics, obtain the waveform appearing on the scope of Fig. 24.37 with a 20-V pulse input at a frequency of 5 kHz.
- Place a capacitor in parallel with  $R_p$  in Fig. 24.37 that will establish an in-phase relationship between  $v_{\text{scope}}$  and  $v_i$ . Using schematics, obtain the waveform appearing on the scope of Fig. 24.37 with a 20-V pulse input at a frequency of 5 kHz.

**Programming Language** (C++, QBASIC, Pascal, etc.)

31. Given a periodic pulse train such as that in Fig. 24.11, write a program to determine the average value, given the base-line voltage, peak value, and duty cycle.
32. Given the initial and final values and the network parameters  $R$  and  $C$ , write a program to tabulate the values of

$v_C$  at each time constant (of the first five) of the transient phase.

33. For the case of  $T/2 < 5\tau$ , as defined by Fig. 24.29, write a program to determine the values of  $v_C$  at each half-period of the applied square wave. Test the solution by entering the conditions of Example 24.10.

**GLOSSARY**

**Actual (true, practical) pulse** A pulse waveform having a leading edge and a trailing edge that are not vertical, along with other distortion effects such as tilt, ringing, or overshoot.

**Amplitude of a pulse waveform** The peak-to-peak value of a pulse waveform.

**Attenuator probe** A scope probe that will reduce the strength of the signal applied to the vertical channel of a scope.

**Base-line voltage** The voltage level from which a pulse is initiated.

**Compensated attenuator probe** A scope probe that can reduce the applied signal and balance the effects of the input capacitance of a scope on the signal to be displayed.

**Duty cycle** Factor that reveals how much of a period is encompassed by the pulse waveform.

**Fall time ( $t_f$ )** The time required for the trailing edge of a pulse waveform to drop from the 90% to the 10% level.

**Ideal pulse** A pulse waveform characterized as having vertical sides, sharp corners, and a flat peak response.

**Negative-going pulse** A pulse that increases in the negative direction from the base-line voltage.

**Periodic pulse train** A sequence of pulses that repeats itself after a specific period of time.

**Positive-going pulse** A pulse that increases in the positive direction from the base-line voltage.

**Pulse repetition frequency (pulse repetition rate)** The frequency of a periodic pulse train.

**Pulse train** A series of pulses that may have varying heights and widths.

**Pulse width ( $t_p$ )** The pulse width defined by the 50% voltage level.

**Rise time ( $t_r$ )** The time required for the leading edge of a pulse waveform to travel from the 10% to the 90% level.

**Square wave** A periodic pulse waveform with a 50% duty cycle.

**Tilt (droop, sag)** The drop in peak value across the pulse width of a pulse waveform.

