

1

Introduction

- 1.1 Electronics
- 1.2 Atomic Structure
- 1.3 Structure of Elements
- 1.4 The Electron
- 1.5 Energy of an Electron
- 1.6 Valence Electrons
- 1.7 Free Electrons
- 1.8 Voltage Source
- 1.9 Constant Voltage Source
- 1.10 Constant Current Source
- 1.11 Conversion of Voltage Source into Current Source
- 1.12 Maximum Power Transfer Theorem
- 1.13 Thevenin's Theorem
- 1.14 Procedure for Finding Thevenin Equivalent Circuit
- 1.15 Norton's Theorem
- 1.16 Procedure for Finding Norton Equivalent Circuit
- 1.17 Chassis and Ground



GENERAL

In this fast developing society, *electronics* has come to stay as the most important branch of engineering. Electronic devices are being used in almost all the industries for quality control and automation and they are fast replacing the present vast army of workers engaged in processing and assembling in the factories. Great strides taken in the industrial applications of electronics during the recent years have demonstrated that this versatile tool can be of great importance in increasing production, efficiency and control.

The rapid growth of electronic technology offers a formidable challenge to the beginner, who may be almost paralysed by the mass of details. However, the mastery of fundamentals can simplify the learning process to a great extent. The purpose of this chapter is to present the elementary knowledge in order to enable the readers to follow the subsequent chapters.

2 ■ Principles of Electronics

1.1 Electronics

The branch of engineering which deals with current conduction through a vacuum or gas or semiconductor is known as ***electronics**.

Electronics essentially deals with electronic devices and their utilisation. An *electronic device* is that

in which current flows through a vacuum or gas or semiconductor. Such devices have valuable properties which enable them to function and behave as the friend of man today.

Importance. Electronics has gained much importance due to its numerous applications in industry. The electronic devices are capable of performing the following functions :

(i) **Rectification.** The conversion of a.c. into d.c. is called *rectification*. Electronic devices can convert a.c. power into d.c. power (See Fig. 1.1) with very high efficiency. This d.c. supply can be used for charging storage batteries, field supply of d.c. generators, electroplating etc.

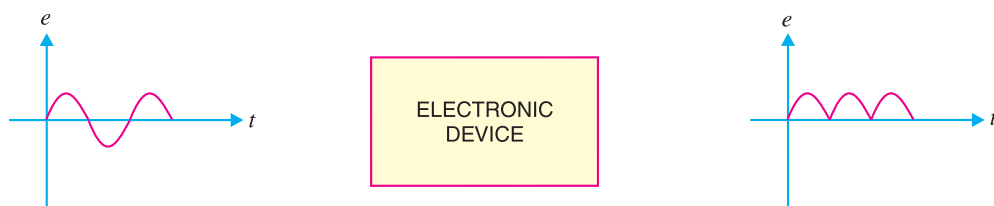

Fig. 1.1

(ii) **Amplification.** The process of raising the strength of a weak signal is known as *amplification*. Electronic devices can accomplish the job of amplification and thus act as amplifiers (See Fig. 1.2). The amplifiers are used in a wide variety of ways. For example, an amplifier is used in a radio-set where the weak signal is amplified so that it can be heard loudly. Similarly, amplifiers are used in public address system, television etc.

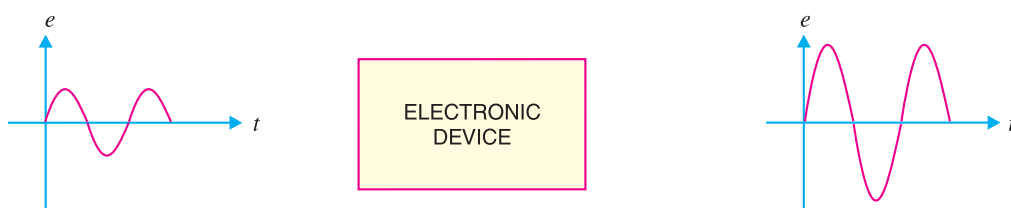

Fig. 1.2

(iii) **Control.** Electronic devices find wide applications in automatic control. For example, speed of a motor, voltage across a refrigerator etc. can be automatically controlled with the help of such devices.

(iv) **Generation.** Electronic devices can convert d.c. power into a.c. power of any frequency (See Fig. 1.3). When performing this function, they are known as *oscillators*. The oscillators are used in a wide variety of ways. For example, electronic high frequency heating is used for annealing and hardening.

* The word *electronics* derives its name from electron present in all materials.

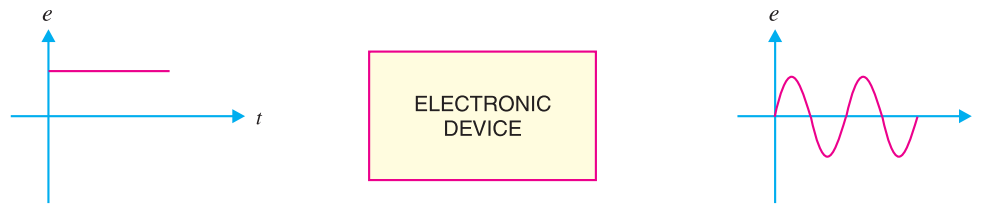

Fig. 1.3

(v) **Conversion of light into electricity.** Electronic devices can convert light into electricity. This conversion of light into electricity is known as *photo-electricity*. Photo-electric devices are used in Burglar alarms, sound recording on motion pictures *etc.*

(vi) **Conversion of electricity into light.** Electronic devices can convert electricity into light. This valuable property is utilised in television and radar.

1.2 Atomic Structure

According to the modern theory, matter is electrical in nature. All the materials are composed of very small particles called *atoms*. The atoms are the building bricks of all matter. An atom consists of a central *nucleus* of positive charge around which small negatively charged particles, called *electrons* revolve in different paths or orbits.

(1) **Nucleus.** It is the central part of an atom and *contains *protons* and *neutrons*. A proton is a positively charged particle, while the neutron has the same mass as the proton, but has no charge. Therefore, the nucleus of an atom is positively charged. The sum of protons and neutrons constitutes the entire weight of an atom and is called atomic weight. It is because the particles in the extra nucleus (*i.e.* electrons) have negligible weight as compared to protons or neutrons.

$$\therefore \text{atomic weight} = \text{no. of protons} + \text{no. of neutrons}$$

(2) **Extra nucleus.** It is the outer part of an atom and contains *electrons* only. An electron is a negatively charged particle having negligible mass. The charge on an electron is equal but opposite to that on a proton. Also, the number of electrons is equal to the number of protons in an atom under ordinary conditions. Therefore, an atom is neutral as a whole. The number of electrons or protons in an atom is called *atomic number i.e.*

$$\text{atomic number} = \text{no. of protons or electrons in an atom}$$

The electrons in an atom revolve around the nucleus in different orbits or paths. The number and arrangement of electrons in any orbit is determined by the following rules :

(i) The number of electrons in any orbit is given by $2n^2$ where n is the number of the orbit. For example,

$$\text{First orbit contains } 2 \times 1^2 = 2 \text{ electrons}$$

$$\text{Second orbit contains } 2 \times 2^2 = 8 \text{ electrons}$$

$$\text{Third orbit contains } 2 \times 3^2 = 18 \text{ electrons}$$

* Although the nucleus of an atom is of complex structure, yet for the purpose of understanding electronics, this simplified picture of the nucleus is adequate.

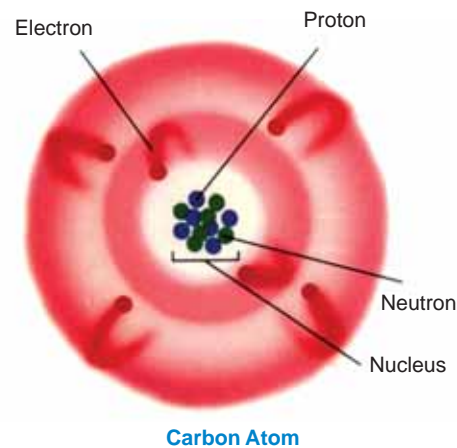

4 ■ Principles of Electronics

and so on.

- (ii) The last orbit cannot have more than 8 electrons.
- (iii) The last but one orbit cannot have more than 18 electrons.

1.3 Structure of Elements

We have seen that all atoms are made up of protons, neutrons and electrons. The difference between various types of elements is due to the different number and arrangement of these particles within their atoms. For example, the structure* of copper atom is different from that of carbon atom and hence the two elements have different properties.

The atomic structure can be easily built up if we know the atomic weight and atomic number of the element. Thus taking the case of copper atom,

$$\begin{aligned} \text{Atomic weight} &= 64 \\ \text{Atomic number} &= 29 \\ \therefore \text{No. of protons} &= \text{No. of electrons} = 29 \\ \text{and No. of neutrons} &= 64 - 29 = 35 \end{aligned}$$

Fig. 1.4 shows the structure of copper atom. It has 29 electrons which are arranged in different orbits as follows. The first orbit will have 2 electrons, the second 8 electrons, the third 18 electrons and the fourth orbit will have 1 electron. The atomic structure of all known elements can be shown in this way and the reader is advised to try for a few commonly used elements.

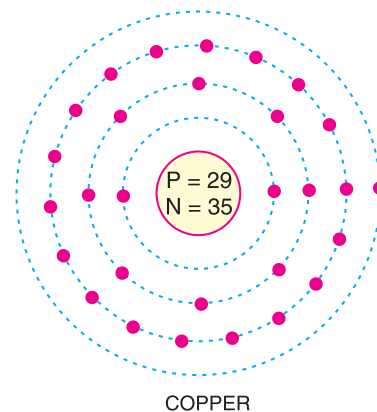

COPPER

Fig. 1.4

1.4 The Electron

Since electronics deals with tiny particles called electrons, these small particles require detailed study. As discussed before, an electron is a negatively charged particle having negligible mass. Some of the important properties of an electron are :

- (i) Charge on an electron, $e = 1.602 \times 10^{-19}$ coulomb
- (ii) Mass of an electron, $m = 9.0 \times 10^{-31}$ kg
- (iii) Radius of an electron, $r = 1.9 \times 10^{-15}$ metre

The ratio e/m of an electron is 1.77×10^{11} coulombs/kg. This means that mass of an electron is very small as compared to its charge. It is due to this property of an electron that it is very mobile and is greatly influenced by electric or magnetic fields.

1.5 Energy of an Electron

An electron moving around the nucleus possesses two types of energies viz. kinetic energy due to its motion and potential energy due to the charge on the nucleus. The total energy of the electron is the sum of these two energies. The energy of an electron increases as its distance from the nucleus increases. Thus, an electron in the second orbit possesses more energy than the electron in the first orbit; electron in the third

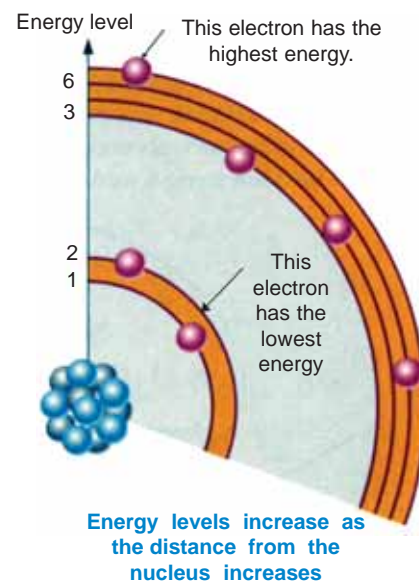

* The number and arrangement of protons, neutrons and electrons.

orbit has higher energy than in the second orbit. It is clear that electrons in the last orbit possess very high energy as compared to the electrons in the inner orbits. These last orbit electrons play an important role in determining the physical, chemical and electrical properties of a material.

1.6 Valence Electrons

The electrons in the outermost orbit of an atom are known as **valence electrons**.

The outermost orbit can have a maximum of 8 electrons *i.e.* the maximum number of valence electrons can be 8. The valence electrons determine the physical and chemical properties of a material. These electrons determine whether or not the material is chemically active; metal or non-metal or, a gas or solid. These electrons also determine the electrical properties of a material.

On the basis of electrical conductivity, materials are generally classified into *conductors*, *insulators* and *semi-conductors*. As a rough rule, one can determine the electrical behaviour of a material from the number of valence electrons as under :

(i) When the number of valence electrons of an atom is less than 4 (*i.e.* half of the maximum eight electrons), the material is usually *a metal and a conductor*. Examples are sodium, magnesium and aluminium which have 1, 2 and 3 valence electrons respectively (See Fig. 1.5).

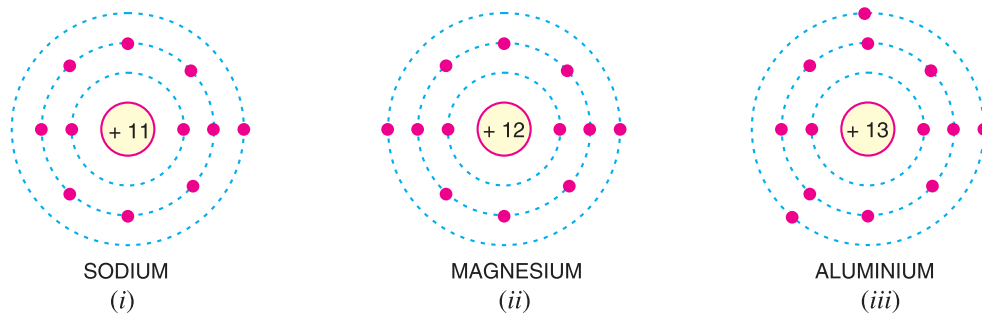

Fig. 1.5

(ii) When the number of valence electrons of an atom is more than 4, the material is usually *a non-metal and an insulator*. Examples are nitrogen, sulphur and neon which have 5, 6 and 8 valence electrons respectively (See Fig. 1.6).

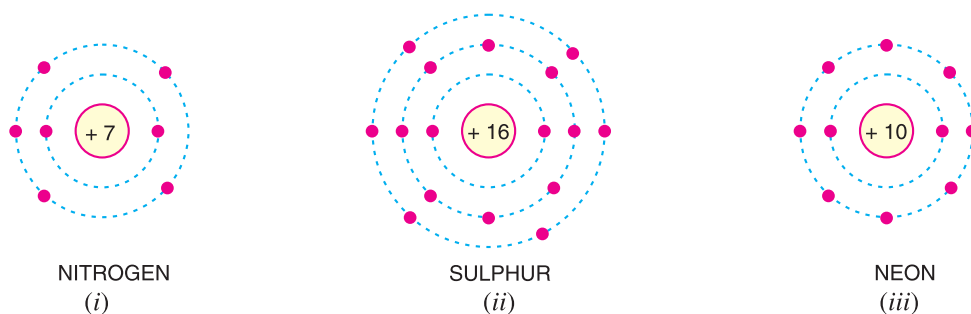

Fig. 1.6

(iii) When the number of valence electrons of an atom is 4 (*i.e.* exactly one-half of the maximum 8 electrons), the material has both metal and non-metal properties and is usually a *semi-conductor*. Examples are carbon, silicon and germanium (See Fig. 1.7).

6 ■ Principles of Electronics

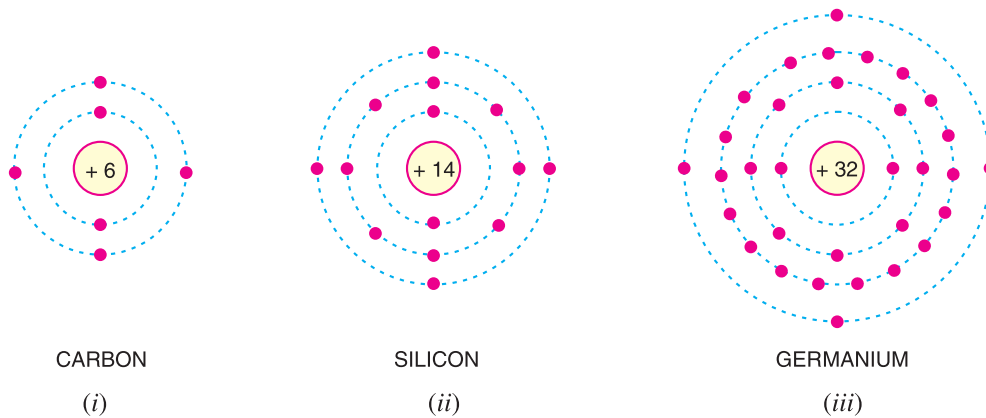

Fig. 1.7

1.7 Free Electrons

The valence electrons of different materials possess different energies. The greater the energy of a valence electron, the lesser it is bound to the nucleus. In certain substances, particularly metals, the valence electrons possess so much energy that they are very loosely attached to the nucleus. These loosely attached valence electrons move at random within the material and are called *free electrons*.

*The valence electrons which are very loosely attached to the nucleus are known as **free electrons**.*

The free electrons can be easily removed or detached by applying a small amount of external energy. As a matter of fact, these are the free electrons which determine the electrical conductivity of a material. On this basis, conductors, insulators and semiconductors can be defined as under :

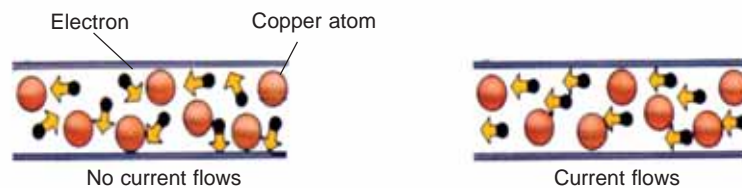

Current moves through materials that conduct electricity.

(i) A **conductor** is a substance which has a large number of free electrons. When potential difference is applied across a conductor, the free electrons move towards the positive terminal of supply, constituting electric current.

(ii) An **insulator** is a substance which has practically no free electrons at ordinary temperature. Therefore, an insulator does not conduct current under the influence of potential difference.

(iii) A **semiconductor** is a substance which has very few free electrons at room temperature. Consequently, under the influence of potential difference, a semiconductor *practically* conducts no current.

1.8 Voltage Source

Any device that produces voltage output continuously is known as a **voltage source**. There are two types of voltage sources, namely ; direct voltage source and alternating voltage source.

(i) **Direct voltage source.** A device which produces direct voltage output continuously is called a **direct voltage source**. Common examples are cells and d.c. generators. An important characteristic of a direct voltage source is that it



Voltage source

maintains the same polarity of the output voltage *i.e.* positive and negative terminals remain the same. When load resistance R_L is connected across such a source, *current flows from positive terminal to negative terminal *via* the load [See Fig. 1.8 (i)]. This is called *direct current* because it has just one direction. The current has one direction as the source maintains the same polarity of output voltage. The opposition to load current inside the d.c. source is known as *internal resistance* R_i . The equivalent circuit of a d.c. source is the generated *e.m.f.* E_g in series with internal resistance R_i of the source as shown in Fig. 1.8 (ii). Referring to Fig. 1.8 (i), it is clear that:

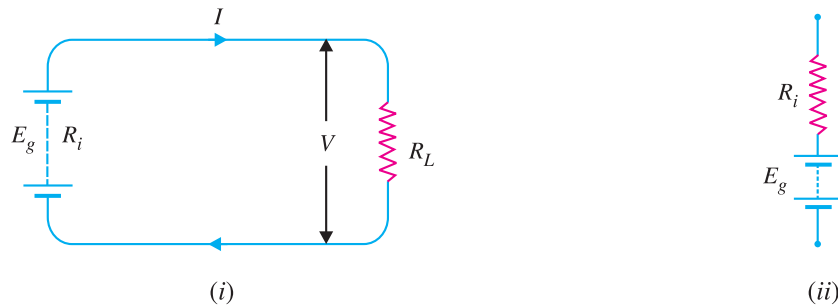

Fig. 1.8

$$\text{Load current, } I = \frac{E_g}{R_L + R_i}$$

$$\text{Terminal voltage, } V = (E_g - IR_i) \text{ or } IR_L$$

(ii) **Alternating voltage source.** A device which produces alternating voltage output continuously is known as *alternating voltage source* *e.g.* a.c. generator. An important characteristic of alternating voltage source is that it periodically reverses the polarity of the output voltage. When load impedance Z_L is connected across such a source, current flows through the circuit that periodically reverses in direction. This is called *alternating current*.

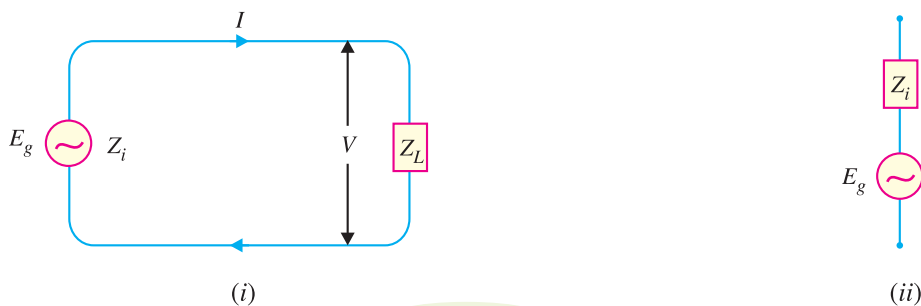

Fig. 1.9

The opposition to load current inside the a.c. source is called its *internal impedance* Z_i . The equivalent circuit of an a.c. source is the generated *e.m.f.* E_g (*r.m.s.*) in series with internal impedance Z_i of the source as shown in Fig. 1.9 (ii). Referring to Fig. 1.9 (i), it is clear that :

$$\text{Load current, } I(\text{r.m.s.}) = \frac{E_g}{Z_L + Z_i}$$

$$\text{Terminal voltage, } V = (E_g - IZ_i)** \text{ or } IZ_L$$

* This is the conventional current. However, the flow of electrons will be in the opposite direction.
 ** Vector difference since a.c. quantities are vector quantities.

8 ■ Principles of Electronics

1.9 Constant Voltage Source

A voltage source which has very low internal *impedance as compared with external load impedance is known as a **constant voltage source**.

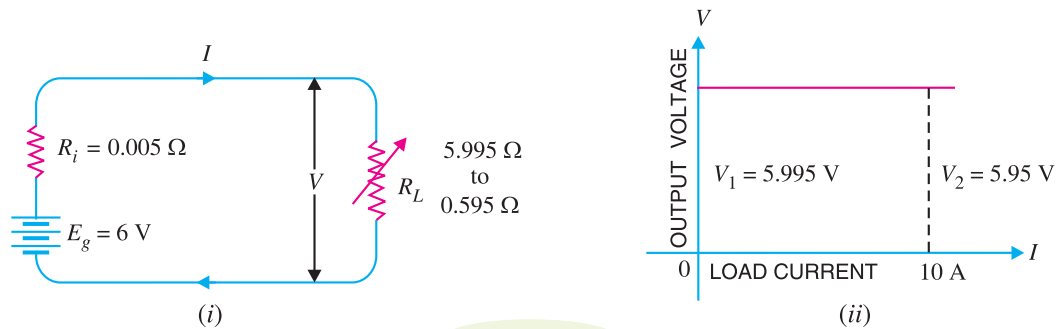

Fig. 1.10

In such a case, the output voltage nearly remains the same when load current changes. Fig. 1.10 (i) illustrates a constant voltage source. It is a d.c. source of 6 V with internal resistance $R_i = 0.005 \Omega$. If the load current varies over a wide range of 1 to 10 A, for any of these values, the internal drop across $R_i (= 0.005 \Omega)$ is less than 0.05 volt. Therefore, the voltage output of the source is between 5.995 to 5.95 volts. This can be considered constant voltage compared with the wide variations in load current.

Fig. 1.10 (ii) shows the graph for a constant voltage source. It may be seen that the output voltage remains constant inspite of the changes in load current. Thus as the load current changes from 0 to 10 A, the output voltage essentially remains the same (i.e. $V_1 = V_2$). A constant voltage source is represented as shown in Fig. 1.11.



Fig. 1.11

Example 1.1. A lead acid battery fitted in a truck develops 24V and has an internal resistance of 0.01Ω . It is used to supply current to head lights etc. If the total load is equal to 100 watts, find :

- (i) voltage drop in internal resistance
- (ii) terminal voltage

Solution.

$$\text{Generated voltage, } E_g = 24 \text{ V}$$

$$\text{Internal resistance, } R_i = 0.01 \Omega$$

$$\text{Power supplied, } P = 100 \text{ watts}$$

(i) Let I be the load current.

$$\text{Now } P = E_g \times I \quad (\because \text{For an ideal source, } V \approx E_g)$$

$$\therefore I = \frac{P}{E_g} = \frac{100}{24} = 4.17 \text{ A}$$

$$\therefore \text{Voltage drop in } R_i = IR_i = 4.17 \times 0.01 = \mathbf{0.0417 \text{ V}}$$

$$\begin{aligned} \text{(ii) Terminal Voltage, } V &= E_g - IR_i \\ &= 24 - 0.0417 = \mathbf{23.96 \text{ V}} \end{aligned}$$

* resistance in case of a d.c. source.

Comments : It is clear from the above example that when internal resistance of the source is quite small, the voltage drop in internal resistance is very low. Therefore, the terminal voltage substantially remains constant and the source behaves as a constant voltage source irrespective of load current variations.

1.10 Constant Current Source

A voltage source that has a very high internal *impedance as compared with external load impedance is considered as a **constant current source**.

In such a case, the load current nearly remains the same when the output voltage changes. Fig. 1.12 (i) illustrates a constant current source. It is a d.c. source of 1000 V with internal resistance $R_i = 900 \text{ k}\Omega$. Here, load R_L varies over 3 : 1 range from 50 k Ω to 150 k Ω . Over this variation of load R_L , the circuit current I is essentially constant at 1.05 to 0.95 mA or approximately 1 mA. It may be noted that output voltage V varies approximately in the same 3 : 1 range as R_L , although load current essentially remains **constant at 1mA. The beautiful example of a constant current source is found in vacuum tube circuits where the tube acts as a generator having internal resistance as high as 1 M Ω .



Constant Current Source

Fig. 1.12 (ii) shows the graph of a constant current source. It is clear that current remains constant even when the output voltage changes substantially. The following points may be noted regarding the constant current source :

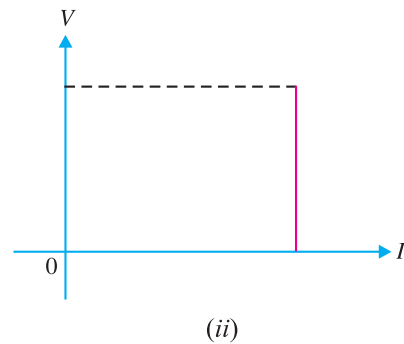
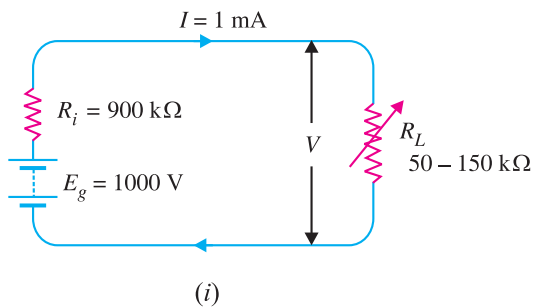

Fig. 1.12

(i) Due to high internal resistance of the source, the load current remains essentially constant as the load R_L is varied.

(ii) The output voltage varies approximately in the same range as R_L , although current remains constant.

(iii) The output voltage V is much less than the generated voltage E_g because of high $I R_i$ drop.

Fig. 1.13 shows the symbol of a constant current source.



Fig. 1.13

* Resistance in case of a d.c. source
 ** Now $I = \frac{E_g}{R_L + R_i}$. Since $R_i \gg R_L$, $I = \frac{E_g}{R_i}$
 As both E_g and R_i are constants, I is constant.

10 ■ Principles of Electronics

Example 1.2. A d.c. source generating 500 V has an internal resistance of 1000 Ω . Find the load current if load resistance is (i) 10 Ω (ii) 50 Ω and (iii) 100 Ω .

Solution.

Generated voltage, $E_g = 500$ V

Internal resistance, $R_i = 1000$ Ω

(i) When $R_L = 10$ Ω

$$\text{Load current, } I = \frac{E_g}{R_L + R_i} = \frac{500}{10 + 1000} = \mathbf{0.495 \text{ A}}$$

(ii) When $R_L = 50$ Ω

$$\text{Load current, } I = \frac{500}{50 + 1000} = \mathbf{0.476 \text{ A}}$$

(iii) When $R_L = 100$ Ω

$$\text{Load current, } I = \frac{500}{100 + 1000} = \mathbf{0.454 \text{ A}}$$

It is clear from the above example that load current is essentially constant since $R_i \gg R_L$.

1.11 Conversion of Voltage Source into Current Source

Fig. 1.14 shows a constant voltage source with voltage V and internal resistance R_i . Fig. 1.15 shows its equivalent current source. It can be easily shown that the two circuits behave electrically the same way under all conditions.

(i) If in Fig. 1.14, the load is open-circuited (*i.e.* $R_L \rightarrow \infty$), then voltage across terminals A and B is V . If in Fig. 1.15, the load is open-circuited (*i.e.* $R_L \rightarrow \infty$), then all current $I (= V/R_i)$ flows through R_i , yielding voltage across terminals $AB = IR_i = V$. Note that open-circuited voltage across AB is V for both the circuits and hence they are electrically equivalent.

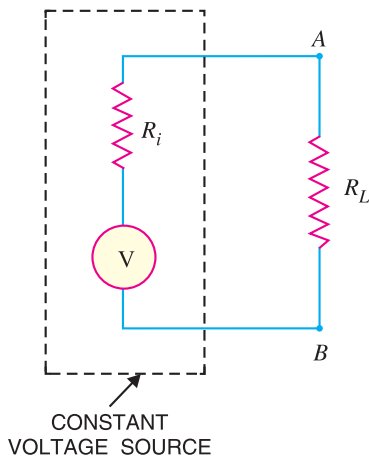

Fig. 1.14

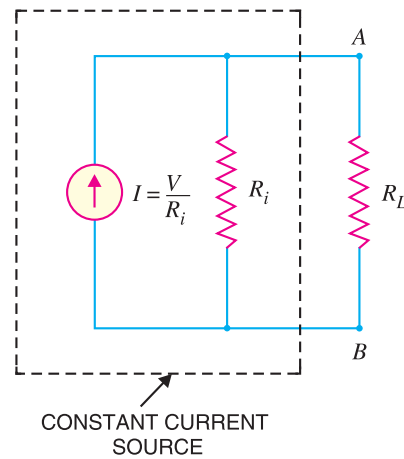

Fig. 1.15

(ii) If in Fig. 1.14, the load is short-circuited (*i.e.* $R_L = 0$), the short circuit current is given by:

$$I_{short} = \frac{V}{R_i}$$

If in Fig. 1.15, the load is short-circuited (*i.e.* $R_L = 0$), the current $I (= V/R_i)$ bypasses R_i in favour of short-circuit. It is clear that current $(= V/R_i)$ is the same for the two circuits and hence they are electrically equivalent.

Thus to convert a constant voltage source into a constant current source, the following procedure may be adopted :

(a) Place a short-circuit across the two terminals in question (terminals AB in the present case) and find the short-circuit current. Let it be I . Then I is the current supplied by the equivalent current source.

(b) Measure the resistance at the terminals with load removed and sources of *e.m.f.s* replaced by their internal resistances if any. Let this resistance be R .

(c) Then equivalent current source can be represented by a single current source of magnitude I in parallel with resistance R .

Note. To convert a current source of magnitude I in parallel with resistance R into voltage source,

$$\text{Voltage of voltage source, } V = IR$$

$$\text{Resistance of voltage source, } R = R$$

Thus voltage source will be represented as voltage V in series with resistance R .

Example 1.3. Convert the constant voltage source shown in Fig. 1.16 into constant current source.

Solution. The solution involves the following steps :

(i) Place a short across AB in Fig. 1.16 and find the short-circuit current I .

$$\text{Clearly, } I = 10/10 = 1 \text{ A}$$

Therefore, the equivalent current source has a magnitude of 1 A.

(ii) Measure the resistance at terminals AB with load *removed and 10 V source replaced by its internal resistance. The 10 V source has negligible resistance so that resistance at terminals AB is $R = 10 \Omega$.

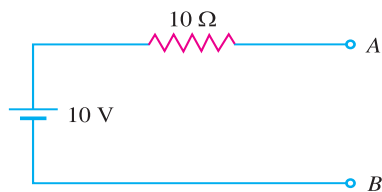

Fig. 1.16

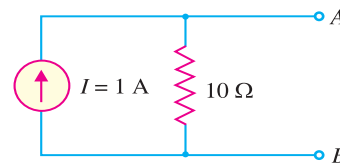

Fig. 1.17

(iii) The equivalent current source is a source of 1 A in parallel with a resistance of 10Ω as shown in Fig. 1.17.

Example 1.4. Convert the constant current source in Fig. 1.18 into equivalent voltage source.

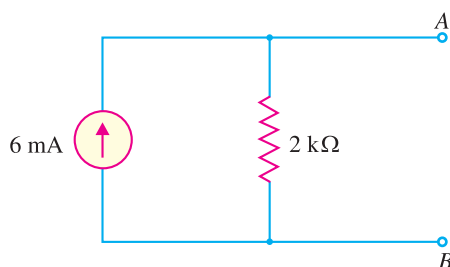

Fig. 1.18

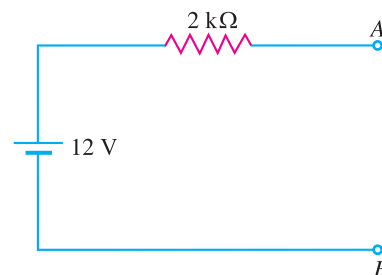

Fig. 1.19

Solution. The solution involves the following steps :

* Fortunately, no load is connected across AB . Had there been load across AB , it would have been removed.

12 ■ Principles of Electronics

(i) To get the voltage of the voltage source, multiply the current of the current source by the internal resistance *i.e.*

$$\text{Voltage of voltage source} = IR = 6 \text{ mA} \times 2 \text{ k}\Omega = 12\text{V}$$

(ii) The internal resistance of voltage source is 2 kΩ.

The equivalent voltage source is a source of 12 V in series with a resistance of 2 kΩ as shown in Fig. 1.19.

Note. The voltage source should be placed with +ve terminal in the direction of current flow.

1.12 Maximum Power Transfer Theorem

When load is connected across a voltage source, power is transferred from the source to the load. The amount of power transferred will depend upon the load resistance. If load resistance R_L is made equal to the internal resistance R_i of the source, then maximum power is transferred to the load R_L . This is known as *maximum power transfer theorem* and can be stated as follows :

Maximum power is transferred from a source to a load when the load resistance is made equal to the internal resistance of the source.

This applies to d.c. as well as a.c. power.*

To prove this theorem mathematically, consider a voltage source of generated voltage E and internal resistance R_i and delivering power to a load resistance R_L [See Fig. 1.20 (i)]. The current I flowing through the circuit is given by :

$$I = \frac{E}{R_L + R_i}$$

$$\text{Power delivered to the load, } P = I^2 R_L = \left(\frac{E}{R_L + R_i} \right)^2 R_L \quad \dots(i)$$

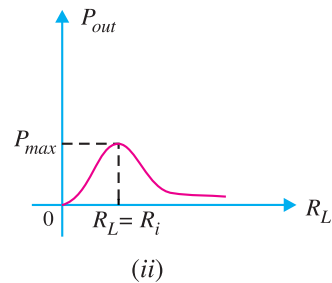
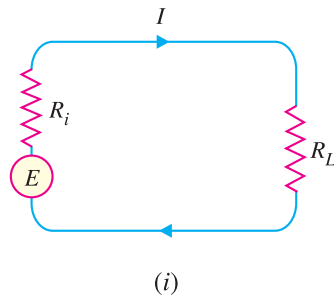

Fig. 1.20

For a given source, generated voltage E and internal resistance R_i are constant. Therefore, power delivered to the load depends upon R_L . In order to find the value of R_L for which the value of P is maximum, it is necessary to differentiate eq. (i) w.r.t. R_L and set the result equal to zero.

$$\text{Thus,} \quad \frac{dP}{dR_L} = E^2 \left[\frac{(R_L + R_i)^2 - 2R_L(R_L + R_i)}{(R_L + R_i)^4} \right] = 0$$

$$\text{or} \quad (R_L + R_i)^2 - 2R_L(R_L + R_i) = 0$$

$$\text{or} \quad (R_L + R_i)(R_L + R_i - 2R_L) = 0$$

$$\text{or} \quad (R_L + R_i)(R_i - R_L) = 0$$

* As power is concerned with resistance only, therefore, this is true for both a.c. and d.c. power.

Since $(R_L + R_i)$ cannot be zero,

$$\therefore R_i - R_L = 0$$

$$\text{or } R_L = R_i$$

i.e. **Load resistance = Internal resistance**

Thus, for maximum power transfer, load resistance R_L must be equal to the internal resistance R_i of the source.

Under such conditions, the load is said to be *matched* to the source. Fig. 1.20 (ii) shows a graph of power delivered to R_L as a function of R_L . It may be mentioned that efficiency of maximum power transfer is *50% as one-half of the total generated power is dissipated in the internal resistance R_i of the source.

Applications. Electric power systems never operate for maximum power transfer because of low efficiency and high voltage drops between generated voltage and load. However, in the electronic circuits, maximum power transfer is usually desirable. For instance, in a public address system, it is desirable to have load (*i.e.* speaker) “matched” to the amplifier so that there is maximum transference of power from the amplifier to the speaker. In such situations, efficiency is **sacrificed at the cost of high power transfer.

Example 1.5. A generator develops 200 V and has an internal resistance of 100 Ω . Find the power delivered to a load of (i) 100 Ω (ii) 300 Ω . Comment on the result.

Solution.

$$\text{Generated voltage, } E = 200 \text{ V}$$

$$\text{Internal resistance, } R_i = 100 \Omega$$

$$(i) \quad \text{When load } R_L = 100 \Omega$$

$$\text{Load current, } I = \frac{E}{R_L + R_i} = \frac{200}{100 + 100} = 1 \text{ A}$$

$$\therefore \text{ Power delivered to load} = I^2 R_L = (1)^2 \times 100 = \mathbf{100 \text{ watts}}$$

$$\text{Total power generated} = I^2 (R_L + R_i) = 1^2 (100 + 100) = 200 \text{ watts}$$

Thus, out of 200 W power developed by the generator, only 100W has reached the load *i.e.* efficiency is 50% only.

$$(ii) \quad \text{When load } R_L = 300 \Omega$$

$$\text{Load current, } I = \frac{E}{R_L + R_i} = \frac{200}{300 + 100} = 0.5 \text{ A}$$

$$\text{Power delivered to load} = I^2 R_L = (0.5)^2 \times 300 = \mathbf{75 \text{ watts}}$$

$$\text{Total power generated} = I^2 (R_L + R_i) = (0.5)^2 (300 + 100) = 100 \text{ watts}$$

Thus, out of 100 watts of power produced by the generator, 75 watts is transferred to the load *i.e.* efficiency is 75%.

Comments. Although in case of $R_L = R_i$, a large power (100 W) is transferred to the load, but there is a big wastage of power in the generator. On the other hand, when R_L is *not* equal to R_i , the

$$* \quad \text{Efficiency} = \frac{\text{output power}}{\text{input power}} = \frac{I^2 R_L}{I^2 (R_L + R_i)}$$

$$= \frac{R_L}{R_L + R_i} = \frac{R_L}{2 R_L} = 1/2 = 50\% \quad (\because R_L = R_i)$$

** Electronic devices develop small power. Therefore, if too much efficiency is sought, a large number of such devices will have to be connected in series to get the desired output. This will distort the output as well as increase the cost and size of equipment.

14 ■ Principles of Electronics

power transfer is less (75 W) but smaller part is wasted in the generator *i.e.* efficiency is high. Thus, it depends upon a particular situation as to what the load should be. If we want to transfer maximum power (*e.g.* in amplifiers) irrespective of efficiency, we should make $R_L = R_i$. However, if efficiency is more important (*e.g.* in power systems), then internal resistance of the source should be considerably smaller than the load resistance.

Example 1.6. An audio amplifier produces an alternating output of 12 V before the connection to a load. The amplifier has an equivalent resistance of 15 Ω at the output. What resistance the load need to have to produce maximum power? Also calculate the power output under this condition.

Solution. In order to produce maximum power, the load (*e.g.* a speaker) should have a resistance of 15 Ω to match the amplifier. The equivalent circuit is shown in Fig. 1.21.

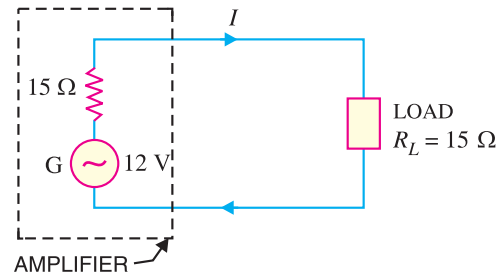

Fig. 1.21

∴ Load required, $R_L = 15 \Omega$

$$\text{Circuit current, } I = \frac{V}{R_T} = \frac{12}{15 + 15} = 0.4 \text{ A}$$

$$\text{Power delivered to load, } P = I^2 R_L = (0.4)^2 \times 15 = 2.4 \text{ W}$$

Example 1.7. For the a.c. generator shown in Fig. 1.22 (i), find (i) the value of load so that maximum power is transferred to the load (ii) the value of maximum power.

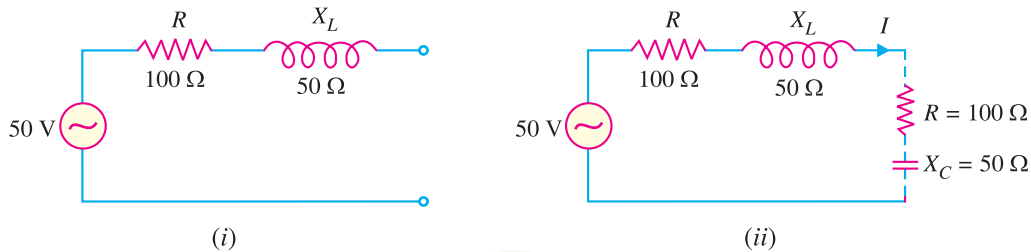

Fig. 1.22

Solution.

(i) In a.c. system, maximum power is delivered to the load impedance (Z_L) when load impedance is conjugate of the internal impedance (Z_i) of the source. Now in the problem, $Z_i = (100 + j50)\Omega$. For maximum power transfer, the load impedance should be conjugate of internal impedance *i.e.* Z_L should be $(100 - j50)\Omega$. This is shown in dotted line in Fig. 1.22 (ii).

$$\therefore Z_L = (100 - j50) \Omega$$

$$(ii) \quad \text{Total impedance, } Z_T = Z_i + Z_L = (100 + j50) + (100 - j50) = 200 \Omega^*$$

$$\text{Circuit current, } I = \frac{V}{Z_T} = \frac{50}{200} = 0.25 \text{ A}$$

$$\text{Maximum power transferred to the load} = I^2 R_L = (0.25)^2 \times 100 = 6.25 \text{ W}$$

* Note that by making internal impedance and load impedance conjugate, the reactive terms cancel. The circuit then consists of internal and external resistances only. This is quite logical because power is only consumed in resistances as reactances (X_L or X_C) consume no power.

1.13 Thevenin's Theorem

Sometimes it is desirable to find a particular branch current in a circuit as the resistance of that branch is varied while all other resistances and voltage sources remain constant. For instance, in the circuit shown in Fig. 1.23, it may be desired to find the current through R_L for five values of R_L , assuming that R_1 , R_2 , R_3 and E remain constant. In such situations, the *solution can be obtained readily by applying *Thevenin's theorem* stated below :

Any two-terminal network containing a number of e.m.f. sources and resistances can be replaced by an equivalent series circuit having a voltage source E_0 in series with a resistance R_0 where,

E_0 = open circuited voltage between the two terminals.

R_0 = the resistance between two terminals of the circuit obtained by looking "in" at the terminals with load removed and voltage sources replaced by their internal resistances, if any.

To understand the use of this theorem, consider the two-terminal circuit shown in Fig. 1.23. The circuit enclosed in the dotted box can be replaced by one voltage E_0 in series with resistance R_0 as shown in Fig. 1.24. The behaviour at the terminals AB and $A'B'$ is the same for the two circuits, independent of the values of R_L connected across the terminals.

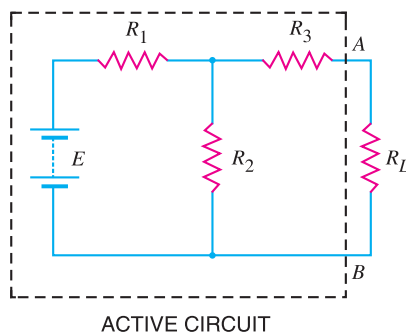

Fig. 1.23

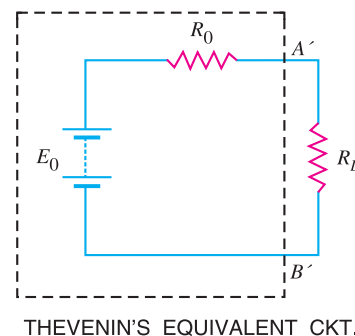

Fig. 1.24

(i) **Finding E_0 .** This is the voltage between terminals A and B of the circuit when load R_L is removed. Fig. 1.25 shows the circuit with load removed. The voltage drop across R_2 is the desired voltage E_0 .

$$\text{Current through } R_2 = \frac{E}{R_1 + R_2}$$

$$\therefore \text{Voltage across } R_2, E_0 = \left(\frac{E}{R_1 + R_2} \right) R_2$$

Thus, voltage E_0 is determined.

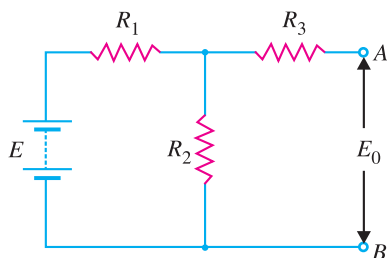

Fig. 1.25

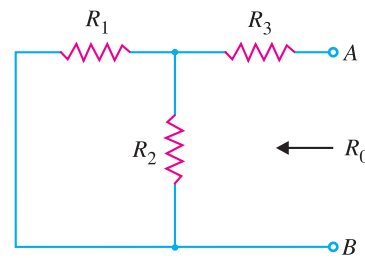

Fig. 1.26

* Solution can also be obtained by applying Kirchhoff's laws but it requires a lot of labour.

16 ■ Principles of Electronics

(ii) **Finding R_0 .** This is the resistance between terminals A and B with load removed and e.m.f. reduced to zero (See Fig. 1.26).

∴ Resistance between terminals A and B is

$$\begin{aligned} R_0 &= \text{parallel combination of } R_1 \text{ and } R_2 \text{ in series with } R_3 \\ &= \frac{R_1 R_2}{R_1 + R_2} + R_3 \end{aligned}$$

Thus, the value of R_0 is determined. Once the values of E_0 and R_0 are determined, then the current through the load resistance R_L can be found out easily (Refer to Fig. 1.24).

1.14 Procedure for Finding Thevenin Equivalent Circuit

- (i) Open the two terminals (*i.e.* remove any load) between which you want to find Thevenin equivalent circuit.
- (ii) Find the open-circuit voltage between the two open terminals. It is called Thevenin voltage E_0 .
- (iii) Determine the resistance between the two open terminals with all ideal voltage sources shorted and all ideal current sources opened (a non-ideal source is replaced by its internal resistance). It is called Thevenin resistance R_0 .
- (iv) Connect E_0 and R_0 in series to produce Thevenin equivalent circuit between the two terminals under consideration.
- (v) Place the load resistor removed in step (i) across the terminals of the Thevenin equivalent circuit. The load current can now be calculated using only Ohm's law and it has the same value as the load current in the original circuit.

Example 1.8. Using Thevenin's theorem, find the current through $100\ \Omega$ resistance connected across terminals A and B in the circuit of Fig. 1.27.

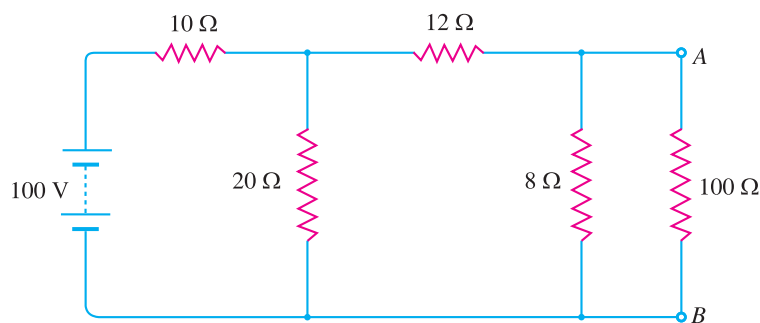

Fig. 1.27

Solution.

(i) **Finding E_0 .** It is the voltage across terminals A and B with $100\ \Omega$ resistance removed as shown in Fig. 1.28.

$$E_0 = (\text{Current through } 8\ \Omega) \times 8\ \Omega = 2.5^* \times 8 = 20\ \text{V}$$

* By solving this series-parallel circuit.

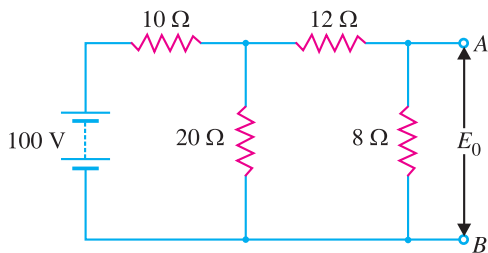

Fig. 1.28

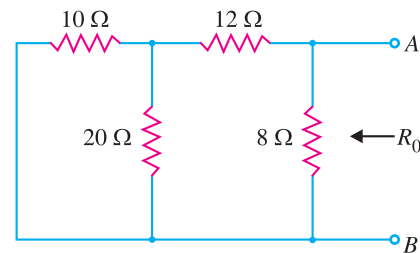

Fig. 1.29

(ii) **Finding R_0 .** It is the resistance between terminals A and B with 100 Ω removed and voltage source short circuited as shown in Fig. 1.29.

R_0 = Resistance looking in at terminals A and B in Fig. 1.29

$$= \frac{\left[\frac{10 \times 20}{10 + 20} + 12 \right] 8}{\left[\frac{10 \times 20}{10 + 20} + 12 \right] + 8}$$

$$= 5.6 \Omega$$

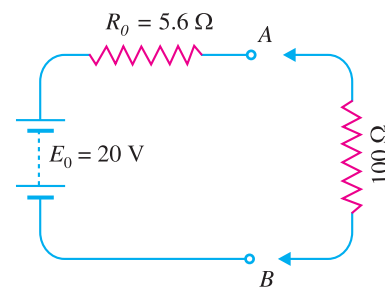

Fig. 1.30

Therefore, Thevenin's equivalent circuit will be as shown in Fig. 1.30. Now, current through 100 Ω resistance connected across terminals A and B can be found by applying Ohm's law.

$$\text{Current through } 100 \Omega \text{ resistor} = \frac{E_0}{R_0 + R_L} = \frac{20}{5.6 + 100} = \mathbf{0.19 \text{ A}}$$

Example 1.9. Find the Thevenin's equivalent circuit for Fig. 1.31.

Solution. The Thevenin's voltage E_0 is the voltage across terminals A and B. This voltage is equal to the voltage across R_3 . It is because terminals A and B are open circuited and there is no current flowing through R_2 and hence no voltage drop across it.

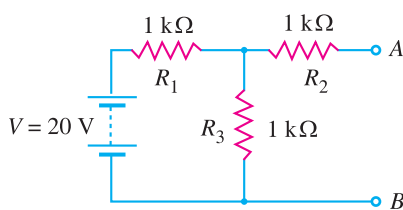

Fig. 1.31

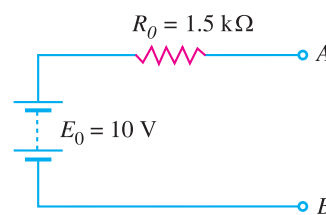

Fig. 1.32

$$\therefore E_0 = \text{Voltage across } R_3$$

$$= \frac{R_3}{R_1 + R_3} \times V = \frac{1}{1 + 1} \times 20 = 10 \text{ V}$$

The Thevenin's resistance R_0 is the resistance measured between terminals A and B with no load (i.e. open at terminals A and B) and voltage source replaced by a short circuit.

$$\therefore R_0 = R_2 + \frac{R_1 R_3}{R_1 + R_3} = 1 + \frac{1 \times 1}{1 + 1} = 1.5 \text{ k}\Omega$$

Therefore, Thevenin's equivalent circuit will be as shown in Fig. 1.32.

18 ■ Principles of Electronics

Example 1.10. Calculate the value of load resistance R_L to which maximum power may be transferred from the circuit shown in Fig. 1.33 (i). Also find the maximum power.

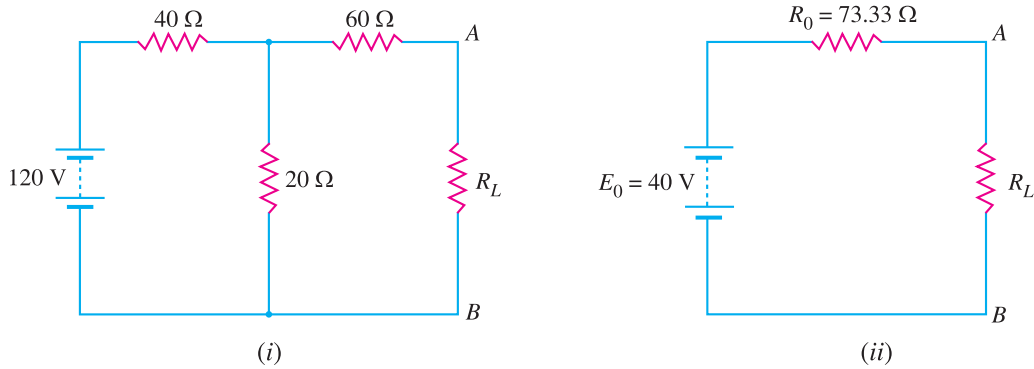

Fig. 1.33

Solution. We shall first find Thevenin's equivalent circuit to the left of terminals AB in Fig. 1.33 (i).

$$\begin{aligned} E_0 &= \text{Voltage across terminals } AB \text{ with } R_L \text{ removed} \\ &= \frac{120}{40 + 20} \times 20 = 40 \text{ V} \end{aligned}$$

$$\begin{aligned} R_0 &= \text{Resistance between terminals } A \text{ and } B \text{ with } R_L \text{ removed and } 120 \text{ V source} \\ &\text{replaced by a short} \\ &= 60 + (40 \Omega \parallel 20 \Omega) = 60 + (40 \times 20)/60 = 73.33 \Omega \end{aligned}$$

The Thevenin's equivalent circuit to the left of terminals AB in Fig. 1.33 (i) is $E_0 (= 40 \text{ V})$ in series with $R_0 (= 73.33 \Omega)$. When R_L is connected between terminals A and B , the circuit becomes as shown in Fig. 1.33 (ii). It is clear that maximum power will be transferred when

$$R_L = R_0 = 73.33 \Omega$$

$$\text{Maximum power to load} = \frac{E_0^2}{4 R_L} = \frac{(40)^2}{4 \times 73.33} = 5.45 \text{ W}$$

Comments. This shows another advantage of Thevenin's equivalent circuit of a network. Once Thevenin's equivalent resistance R_0 is calculated, it shows at a glance the condition for maximum power transfer. Yet Thevenin's equivalent circuit conveys another information. Thus referring to Fig. 1.33 (ii), the maximum voltage that can appear across terminals A and B is 40 V. This is not so obvious from the original circuit shown in Fig. 1.33 (i).

Example 1.11. Calculate the current in the 50Ω resistor in the network shown in Fig. 1.34.

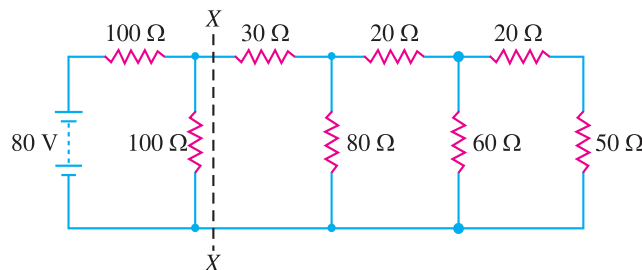

Fig. 1.34

Solution. We shall simplify the circuit shown in Fig. 1.34 by the repeated use of Thevenin's theorem. We first find Thevenin's equivalent circuit to the left of *XX.

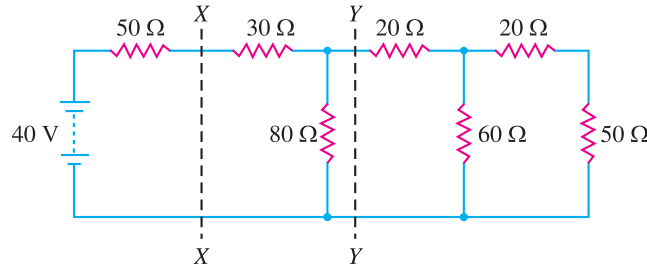

Fig. 1.35

$$E_0 = \frac{80}{100 + 100} \times 100 = 40\text{V}$$

$$R_0 = 100 \parallel 100 = \frac{100 \times 100}{100 + 100} = 50 \Omega$$

Therefore, we can replace the circuit to the left of XX in Fig. 1.34 by its Thevenin's equivalent circuit viz. $E_0 (= 40\text{V})$ in series with $R_0 (= 50 \Omega)$. The original circuit of Fig. 1.34 then reduces to the one shown in Fig. 1.35.

We shall now find Thevenin's equivalent circuit to left of YY in Fig. 1.35.

$$E'_0 = \frac{40}{50 + 30 + 80} \times 80 = 20 \text{ V}$$

$$R'_0 = (50 + 30) \parallel 80 = \frac{80 \times 80}{80 + 80} = 40 \Omega$$

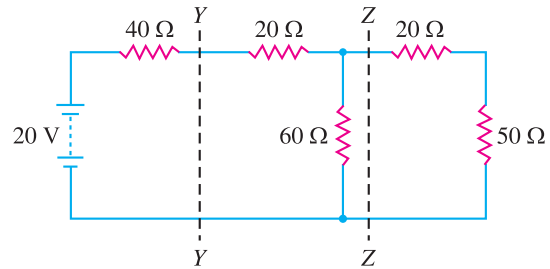
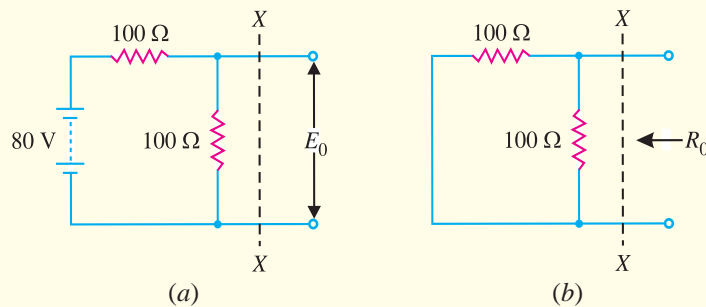

Fig. 1.36

We can again replace the circuit to the left of YY in Fig. 1.35 by its Thevenin's equivalent circuit. Therefore, the original circuit reduces to that shown in Fig. 1.36.

*



$$E_0 = \text{Current in } 100 \Omega \times 100 \Omega = \frac{80}{100 + 100} \times 100 = 40\text{V} \text{ [See Fig. (a)]}$$

$$R_0 = \text{Resistance looking in the open terminals in Fig. (b)}$$

$$= 100 \parallel 100 = \frac{100 \times 100}{100 + 100} = 50 \Omega$$

20 ■ Principles of Electronics

Using the same procedure to the left of ZZ, we have,

$$E''_0 = \frac{20}{40 + 20 + 60} \times 60 = 10\text{V}$$

$$R''_0 = (40 + 20) \parallel 60 = \frac{60 \times 60}{60 + 60} = 30 \Omega$$

The original circuit then reduces to that shown in Fig. 1.37.

By Ohm's law, current I in 50Ω resistor is

$$I = \frac{10}{30 + 20 + 50} = 0.1 \text{ A}$$

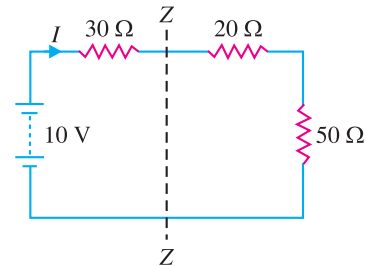

Fig. 1.37

1.15 Norton's Theorem

Fig. 1.38 (i) shows a network enclosed in a box with two terminals A and B brought out. The network in the box may contain any number of resistors and e.m.f. sources connected in any manner. But according to Norton, the entire circuit behind terminals A and B can be replaced by a current source of output I_N in parallel with a single resistance R_N as shown in Fig. 1.38 (ii). The value of I_N is determined as mentioned in Norton's theorem. The resistance R_N is the same as Thevenin's resistance R_0 . Once Norton's equivalent circuit is determined [See Fig. 1.38 (ii)], then current through any load R_L connected across terminals AB can be readily obtained.

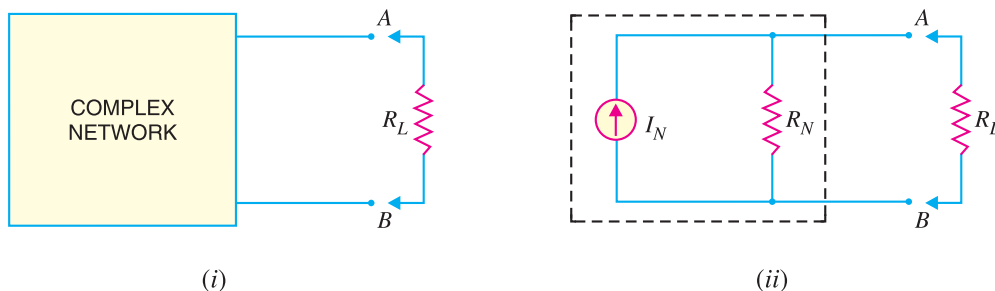

Fig. 1.38

Hence Norton's theorem as applied to d.c. circuits may be stated as under :

Any network having two terminals A and B can be replaced by a current source of output I_N in parallel with a resistance R_N .

(i) The output I_N of the current source is equal to the current that would flow through AB when terminals A and B are short circuited.

(ii) The resistance R_N is the resistance of the network measured between terminals A and B with load (R_L) removed and sources of e.m.f. replaced by their internal resistances, if any.

Norton's theorem is *converse* of Thevenin's theorem in that Norton equivalent circuit uses a current generator instead of voltage generator and resistance R_N (which is the same as R_0) in parallel with the generator instead of being in series with it.

Illustration. Fig. 1.39 illustrates the application of Norton's theorem. As far as circuit behind terminals AB is concerned [See Fig. 1.39 (i)], it can be replaced by a current source of output I_N in parallel with a resistance R_N as shown in Fig. 1.39 (iv). The output I_N of the current generator is equal to the current that would flow through AB when terminals A and B are short-circuited as shown in Fig. 1.39 (ii). The load R' on the source when terminals AB are short-circuited is given by :

$$R' = R_1 + \frac{R_2 R_3}{R_2 + R_3} = \frac{R_1 R_2 + R_1 R_3 + R_2 R_3}{R_2 + R_3}$$

$$\text{Source current, } I' = \frac{V}{R'} = \frac{V(R_2 + R_3)}{R_1 R_2 + R_1 R_3 + R_2 R_3}$$

Short-circuit current, I_N = Current in R_2 in Fig. 1.39 (ii)

$$= I' \times \frac{R_3}{R_2 + R_3} = \frac{V R_3}{R_1 R_2 + R_1 R_3 + R_2 R_3}$$

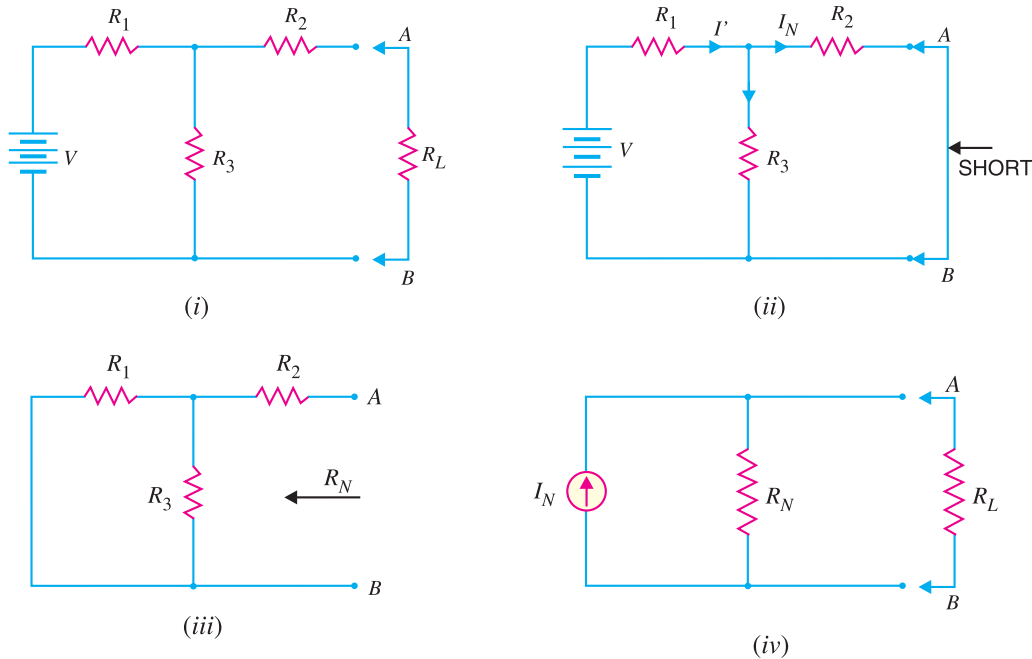

Fig. 1.39

To find R_N , remove the load R_L and replace the voltage source by a short circuit because its resistance is assumed zero [See Fig. 1.39 (iii)].

$$\begin{aligned} \therefore R_N &= \text{Resistance at terminals } AB \text{ in Fig. 1.39 (iii).} \\ &= R_2 + \frac{R_1 R_3}{R_1 + R_3} \end{aligned}$$

Thus the values of I_N and R_N are known. The Norton equivalent circuit will be as shown in Fig. 1.39 (iv).

1.16 Procedure for Finding Norton Equivalent Circuit

(i) Open the two terminals (*i.e.* remove any load) between which we want to find Norton equivalent circuit.

(ii) Put a short-circuit across the terminals under consideration. Find the short-circuit current flowing in the short circuit. It is called Norton current I_N .

(iii) Determine the resistance between the two open terminals with all ideal voltage sources shorted and all ideal current sources opened (a non-ideal source is replaced by its internal resistance). It is called Norton's resistance R_N . It is easy to see that $R_N = R_0$.

(iv) Connect I_N and R_N in parallel to produce Norton equivalent circuit between the two terminals under consideration.

22 ■ Principles of Electronics

(v) Place the load resistor removed in step (i) across the terminals of the Norton equivalent circuit. The load current can now be calculated by using current-divider rule. This load current will be the same as the load current in the original circuit.

Example 1.12. Using Norton's theorem, find the current in $8\ \Omega$ resistor in the network shown in Fig. 1.40 (i).

Solution. We shall reduce the network to the left of AB in Fig. 1.40 (i) to Norton's equivalent circuit. For this purpose, we are required to find I_N and R_N .

(i) With load (*i.e.*, $8\ \Omega$) removed and terminals AB short circuited [See Fig. 1.40 (ii)], the current that flows through AB is equal to I_N . Referring to Fig. 1.40 (ii),

$$\begin{aligned}\text{Load on the source} &= 4\ \Omega + 5\ \Omega \parallel 6\ \Omega \\ &= 4 + \frac{5 \times 6}{5 + 6} = 6.727\ \Omega\end{aligned}$$

$$\text{Source current, } I' = 40/6.727 = 5.94\ \text{A}$$

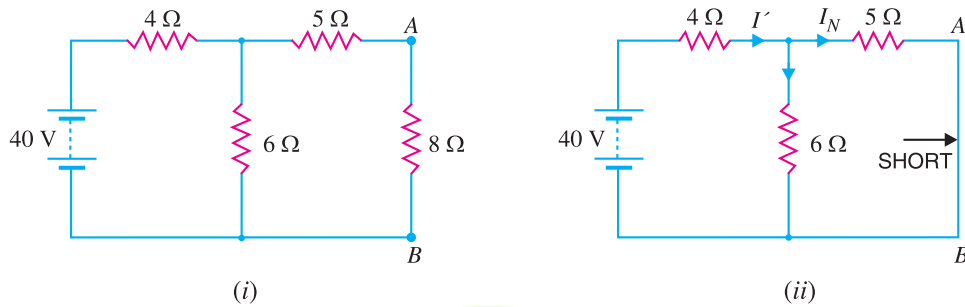

Fig. 1.40

$$\therefore \text{ Short-circuit current in } AB, I_N = I' \times \frac{6}{6 + 5} = 5.94 \times 6/11 = 3.24\ \text{A}$$

(ii) With load (*i.e.*, $8\ \Omega$) removed and battery replaced by a short (since its internal resistance is assumed zero), the resistance at terminals AB is equal to R_N as shown in Fig. 1.41 (i).

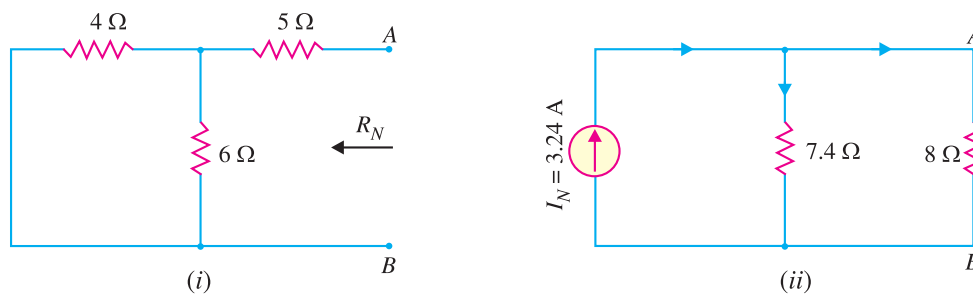

Fig. 1.41

$$R_N = 5\ \Omega + 4\ \Omega \parallel 6\ \Omega = 5 + \frac{4 \times 6}{4 + 6} = 7.4\ \Omega$$

The Norton's equivalent circuit behind terminals AB is $I_N (= 3.24\ \text{A})$ in parallel with $R_N (= 7.4\ \Omega)$. When load (*i.e.*, $8\ \Omega$) is connected across terminals AB , the circuit becomes as shown in Fig. 1.41 (ii). The current source is supplying current to two resistors $7.4\ \Omega$ and $8\ \Omega$ in parallel.

$$\therefore \text{ Current in } 8\ \Omega \text{ resistor} = 3.24 \times \frac{7.4}{8 + 7.4} = \mathbf{1.55\ \text{A}}$$

Example 1.13. Find the Norton equivalent circuit at terminals X – Y in Fig. 1.42.

Solution. We shall first find the Thevenin equivalent circuit and then convert it to an equivalent current source. This will then be Norton equivalent circuit.

Finding Thevenin Equivalent circuit. To find E_0 , refer to Fig. 1.43 (i). Since 30 V and 18 V sources are in opposition, the circuit current I is given by :

$$I = \frac{30 - 18}{20 + 10} = \frac{12}{30} = 0.4 \text{ A}$$

Applying Kirchhoff's voltage law to loop ABCDA, we have,

$$30 - 20 \times 0.4 - E_0 = 0 \quad \therefore E_0 = 30 - 8 = 22 \text{ V}$$

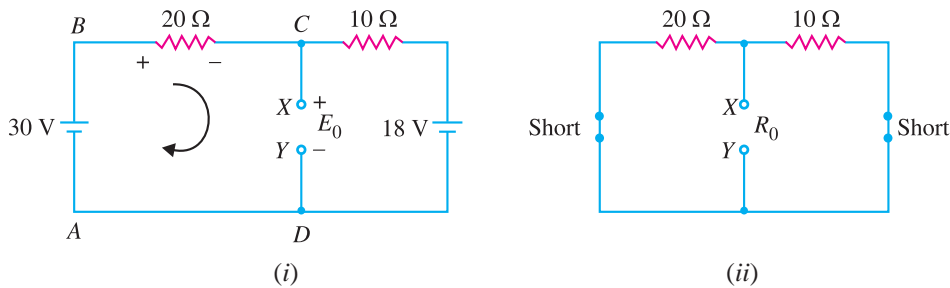

Fig. 1.43

To find R_0 , we short both voltage sources as shown in Fig. 1.43 (ii). Notice that 10 Ω and 20 Ω resistors are then in parallel.

$$\therefore R_0 = 10 \Omega \parallel 20 \Omega = \frac{10 \times 20}{10 + 20} = 6.67 \Omega$$

Therefore, Thevenin equivalent circuit will be as shown in Fig. 1.44 (i). Now it is quite easy to convert it into equivalent current source.

$$I_N = \frac{E_0}{R_0} = \frac{22}{6.67} = 3.3 \text{ A}$$

[See Fig. 1.44 (ii)]

$$R_N = R_0 = 6.67 \Omega$$

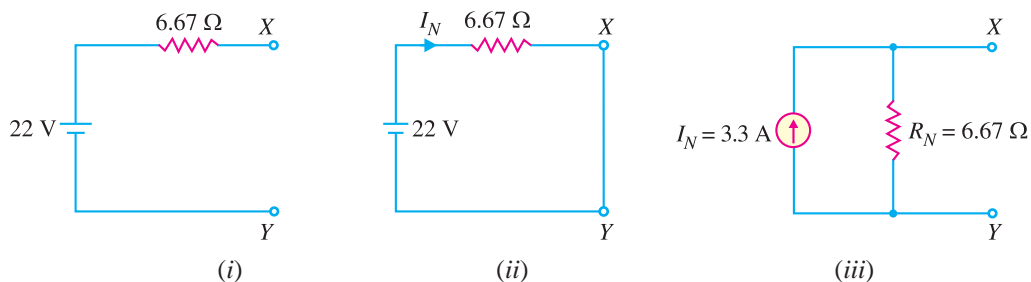

Fig. 1.44

Fig. 1.44 (iii) shows Norton equivalent circuit. Observe that the Norton equivalent resistance has the same value as the Thevenin equivalent resistance. Therefore, R_N is found exactly the same way.

24 ■ Principles of Electronics

Example 1.14. Show that when Thevenin's equivalent circuit of a network is converted into Norton's equivalent circuit, $I_N = E_0/R_0$ and $R_N = R_0$. Here E_0 and R_0 are Thevenin voltage and Thevenin resistance respectively.

Solution. Fig. 1.45 (i) shows a network enclosed in a box with two terminals A and B brought out. Thevenin's equivalent circuit of this network will be as shown in Fig. 1.45 (ii). To find Norton's equivalent circuit, we are to find I_N and R_N . Referring to Fig. 1.45 (ii),

$$\begin{aligned} I_N &= \text{Current flowing through short-circuited } AB \text{ in Fig. 1.45 (ii)} \\ &= E_0/R_0 \\ R_N &= \text{Resistance at terminals } AB \text{ in Fig. 1.45 (ii)} \\ &= R_0 \end{aligned}$$

Fig. 1.45 (iii) shows Norton's equivalent circuit. Hence we arrive at the following two important conclusions :

(i) To convert Thevenin's equivalent circuit into Norton's equivalent circuit,

$$I_N = E_0/R_0 \quad ; \quad R_N = R_0$$

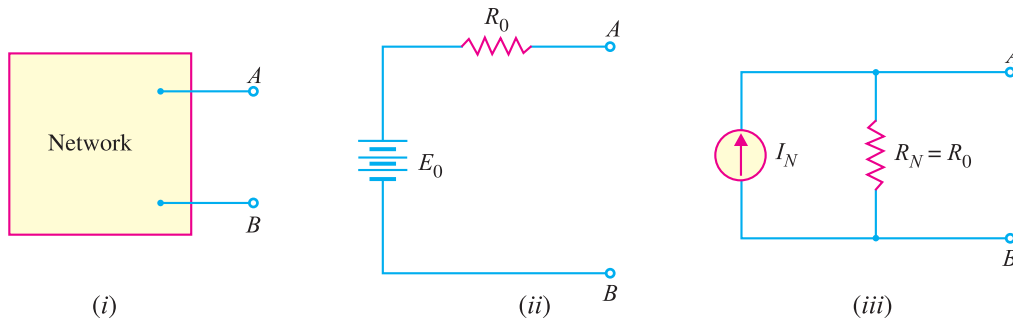

Fig. 1.45

(ii) To convert Norton's equivalent circuit into Thevenin's equivalent circuit,

$$E_0 = I_N R_N \quad ; \quad R_0 = R_N$$

1.17 Chassis and Ground

It is the usual practice to mount the electronic components on a metal base called *chassis*. For example, in Fig. 1.46, the voltage source and resistors are connected to the chassis. As the resistance of chassis is very low, therefore, it provides a conducting path and may be considered as a piece of wire.

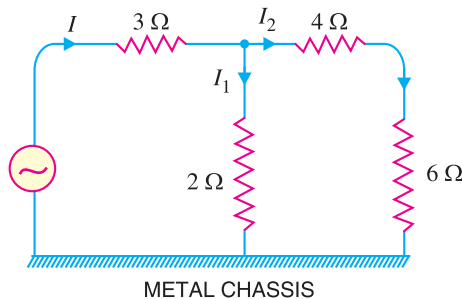

Fig. 1.46

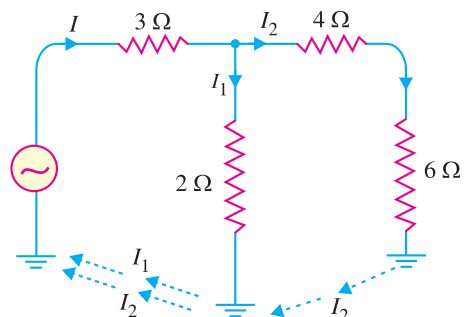

Fig. 1.47

It is customary to refer to the chassis as *ground*. Fig. 1.47 shows the symbol for chassis. It may be seen that all points connected to chassis are shown as grounded and represent the same potential. The adoption of this scheme (*i.e.* showing points of same potential as grounded) often simplifies the electronic circuits. In our further discussion, we shall frequently use this scheme.

MULTIPLE-CHOICE QUESTIONS

1. The outermost orbit of an atom can have a maximum of electrons.
 - (i) 8
 - (ii) 6
 - (iii) 4
 - (iv) 3
2. When the outermost orbit of an atom has less than 4 electrons, the material is generally a
 - (i) non-metal
 - (ii) metal
 - (iii) semiconductor
 - (iv) none of above
3. The valence electrons have
 - (i) very small energy
 - (ii) least energy
 - (iii) maximum energy
 - (iv) none of the above
4. A large number of free electrons exist in
 - (i) semiconductors
 - (ii) metals
 - (iii) insulators
 - (iv) non-metals
5. An ideal voltage source has internal resistance.
 - (i) small
 - (ii) large
 - (iii) infinite
 - (iv) zero
6. An ideal current source has internal resistance.
 - (i) infinite
 - (ii) zero
 - (iii) small
 - (iv) none of the above
7. Maximum power is transferred if load resistance is equal to of the source.
 - (i) half the internal resistance
 - (ii) internal resistance
 - (iii) twice the internal resistance
 - (iv) none of the above
8. Efficiency at maximum power transfer is
 - (i) 75%
 - (ii) 25%
 - (iii) 90%
 - (iv) 50%
9. When the outermost orbit of an atom has exactly 4 valence electrons, the material is generally
 - (i) a metal
 - (ii) a non-metal
 - (iii) a semiconductor
 - (iv) an insulator
10. Thevenin's theorem replaces a complicated circuit facing a load by an
 - (i) ideal voltage source and parallel resistor
 - (ii) ideal current source and parallel resistor
 - (iii) ideal current source and series resistor
 - (iv) ideal voltage source and series resistor
11. The output voltage of an ideal voltage source is
 - (i) zero
 - (ii) constant
 - (iii) dependent on load resistance
 - (iv) dependent on internal resistance
12. The current output of an ideal current source is
 - (i) zero
 - (ii) constant
 - (iii) dependent on load resistance
 - (iv) dependent on internal resistance
13. Norton's theorem replaces a complicated circuit facing a load by an
 - (i) ideal voltage source and parallel resistor
 - (ii) ideal current source and parallel resistor
 - (iii) ideal voltage source and series resistor
 - (iv) ideal current source and series resistor
14. The practical example of ideal voltage source is
 - (i) lead-acid cell
 - (ii) dry cell
 - (iii) Daniel cell
 - (iv) none of the above
15. The speed of electrons in vacuum is than in a conductor.
 - (i) less
 - (ii) much more
 - (iii) much less
 - (iv) none of the above
16. Maximum power will be transferred from a source of $10\ \Omega$ resistance to a load of
 - (i) $5\ \Omega$
 - (ii) $20\ \Omega$
 - (iii) $10\ \Omega$
 - (iv) $40\ \Omega$
17. When the outermost orbit of an atom has more than 4 electrons, the material is generally a
 - (i) metal
 - (ii) non-metal
 - (iii) semiconductor
 - (iv) none of the above

26 ■ Principles of Electronics

18. An ideal source consists of 5 V in series with 10 k Ω resistance. The current magnitude of equivalent current source is
- (i) 2 mA (ii) 3.5 mA
(iii) 0.5 mA (iv) none of the above
19. To get Thevenin voltage, you have to
- (i) short the load resistor
(ii) open the load resistor
(iii) short the voltage source
(iv) open the voltage source
20. To get the Norton current, you have to
- (i) short the load resistor
(ii) open the load resistor
(iii) short the voltage source
(iv) open the voltage source
21. The open-circuited voltage at the terminals of load R_L in a network is 30 V. Under the conditions of maximum power transfer, the load voltage will be
- (i) 30 V (ii) 10 V
(iii) 5 V (iv) 15 V
22. Under the conditions of maximum power transfer, a voltage source is delivering a power of 30 W to the load. The power produced by the source is
- (i) 45 W (ii) 60 W
(iii) 30 W (iv) 90 W
23. The maximum power transfer theorem is used in
- (i) electronic circuits
(ii) power system
(iii) home lighting circuits
(iv) none of the above
24. The Norton resistance of a network is 20 Ω and the shorted-load current is 2 A. If the network is loaded by a resistance equal to 20 Ω , the current through the load will be
- (i) 2 A (ii) 0.5 A
(iii) 4 A (iv) 1 A
25. The Norton current is sometimes called the
- (i) shorted-load current
(ii) open-load current
(iii) Thevenin current
(iv) Thevenin voltage

Answers to Multiple-Choice Questions

- | | | | | |
|-----------|----------|-----------|----------|----------|
| 1. (i) | 2. (ii) | 3. (iii) | 4. (ii) | 5. (iv) |
| 6. (i) | 7. (ii) | 8. (iv) | 9. (iii) | 10. (iv) |
| 11. (ii) | 12. (ii) | 13. (ii) | 14. (i) | 15. (ii) |
| 16. (iii) | 17. (ii) | 18. (iii) | 19. (ii) | 20. (i) |
| 21. (iv) | 22. (ii) | 23. (i) | 24. (iv) | 25. (i) |

Chapter Review Topics

- What is electronics ? Mention some important applications of electronics.
- Describe briefly the structure of atom.
- Explain how valence electrons determine the electrical properties of a material.
- Explain constant voltage and current sources. What is their utility ?
- Derive the condition for transfer of maximum power from a source to a load.
- State and explain Thevenin's theorem.
- Write short notes on the following :
(i) Atomic structure (ii) Valence electrons (iii) Free electrons

Problems

- A dry battery developing 12 V has an internal resistance of 10 Ω . Find the output current if load is (i) 100 Ω (ii) 10 Ω (iii) 2 Ω and (iv) 1 Ω .
[(i) 0.1A (ii) 0.6A (iii) 1A (iv) 1.1A]
- Convert the current source in Fig. 1.48 into the equivalent voltage source.
[36 V in series with 900 Ω]

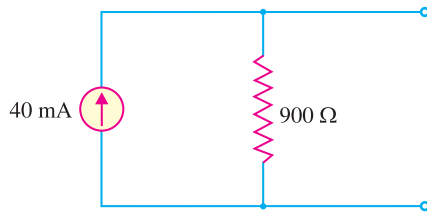

Fig. 1.48

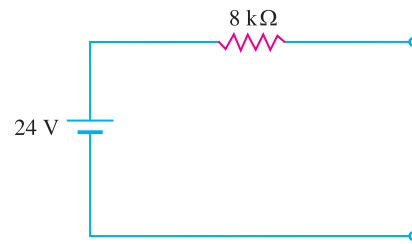

Fig. 1.49

- Convert the voltage source in Fig. 1.49 into equivalent current source. **[3 mA in parallel with 8 kΩ]**
- Using Norton's Theorem, find the current in branch AB containing $6\ \Omega$ resistor of the network shown in Fig. 1.50. **[0.466 A]**

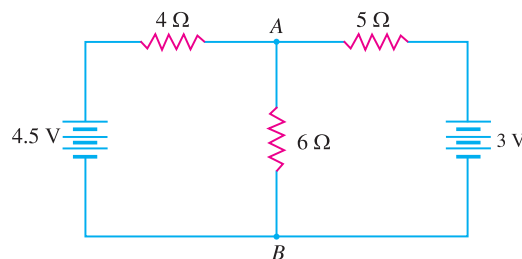

Fig. 1.50

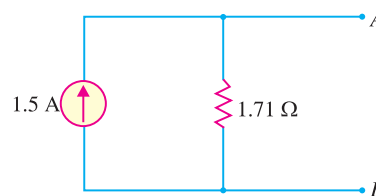

Fig. 1.51

- Fig. 1.51 shows Norton's equivalent circuit of a network behind terminals A and B . Convert it into Thevenin's equivalent circuit. **[2.56 V in series with 1.71 Ω]**

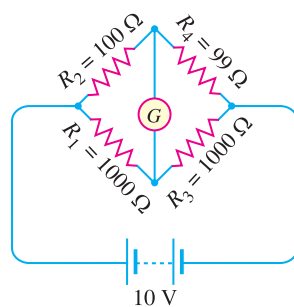

Fig. 1.52

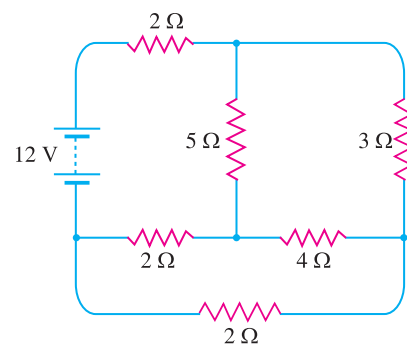

Fig. 1.53

- A power amplifier has an internal resistance of $5\ \Omega$ and develops open circuited voltage of $12\ \text{V}$. Find the efficiency and power transferred to a load of (i) $20\ \Omega$ (ii) $5\ \Omega$. **[(i) 80%, 4.6 W (ii) 50%, 7.2 W]**
- Using Thevenin's theorem, find the current through the galvanometer in the Wheatstone bridge shown in Fig. 1.52. **[38.6 μA]**
- Using Thevenin's theorem, find the current through $4\ \Omega$ resistor in the circuit of Fig. 1.53. **[0.305A]**

Discussion Questions

- Why are free electrons most important for electronics ?
- Why do insulators not have any free electrons ?
- Where do you apply Thevenin's theorem ?
- Why is maximum power transfer theorem important in electronic circuits ?
- What are the practical applications of a constant current source ?