

21

Power Electronics

- 21.1 Power Electronics
- 21.2 The Triac
- 21.3 Triac Construction
- 21.4 SCR Equivalent Circuit of Triac
- 21.5 Triac Operation
- 21.6 Triac Characteristics
- 21.7 Triac Phase Control Circuit
- 21.8 Applications of Triac
- 21.9 The Diac
- 21.10 Applications of Diac
- 21.11 Unijunction Transistor (UJT)
- 21.12 Equivalent Circuit of a UJT
- 21.13 Characteristics of UJT
- 21.14 Advantages of UJT
- 21.15 Applications of UJT

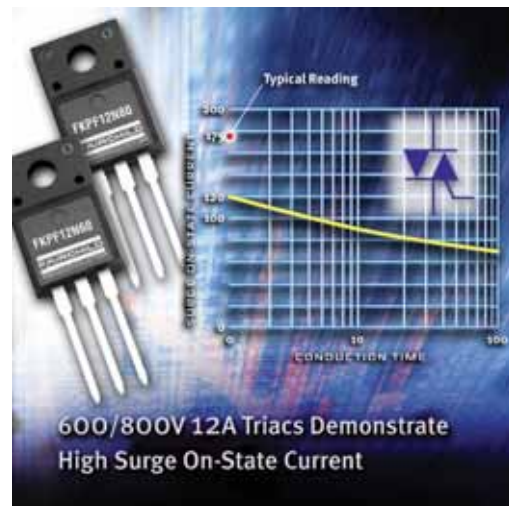

INTRODUCTION

Since the 1950's there has been a great upsurge in the development, production and applications of semiconductor devices. Today there are well over 100 million semiconductor devices manufactured in a year. These figures alone indicate how important semiconductor devices have become to the electrical industry. In fact, the present day advancement in technology is largely attributed to the widespread use of semiconductor devices in the commercial and industrial fields.

One major field of application of semiconductor devices in the recent years has been to control large blocks of power flow in a system. This has led to the development of a new branch of engineering called power electronics. The purpose of this chapter is to acquaint the readers with some important switching devices much used in power electronics.

21.1 Power Electronics

*The branch of electronics which deals with the control of power at 50 Hz (i.e. supply frequency) is known as **power electronics**.*

578 ■ Principles of Electronics

There are many applications where it is desired to control (or regulate) the power fed to a load *e.g.* to change the speed of a fan or motor. So far we have been using electrical methods to exercise such a control. However, electrical methods do not permit a *fine control over the flow of power in a system. Moreover, there is a considerable wastage of power. In the recent years, such semiconductor devices have been developed which can exercise fine control over the flow of large blocks of power in a system. Such devices act as controlled switches and can perform the duties of controlled rectification, inversion and regulation of power in a load. The important semiconductor switching devices are :

- (i) Silicon controlled rectifier (SCR)
- (ii) Triac
- (iii) Diac
- (iv) Unijunction transistor (UJT)

The silicon controlled rectifier (SCR) has already been discussed in the previous chapter. Therefore, we shall deal with the other three switching devices in the following discussion.

21.2 The Triac

The major drawback of an SCR is that it can conduct current in one direction only. Therefore, an SCR can only control d.c. power or forward biased half-cycles of a.c. in a load. However, in an a.c. system, it is often desirable and necessary to exercise control over both positive and negative half-cycles. For this purpose, a semiconductor device called *triac* is used.

A *triac* is a three-terminal semiconductor switching device which can control alternating current in a load.

Triac is an abbreviation for *triode a.c. switch*. ‘Tri’- indicates that the device has three terminals and ‘ac’ means that the device controls alternating current or can conduct current in either direction.

The key function of a triac may be understood by referring to the simplified Fig. 21.1. The **control circuit of triac can be adjusted to pass the desired portions of positive and negative half-cycle of a.c. supply through the load R_L . Thus referring to Fig. 21.1 (ii), the triac passes the positive

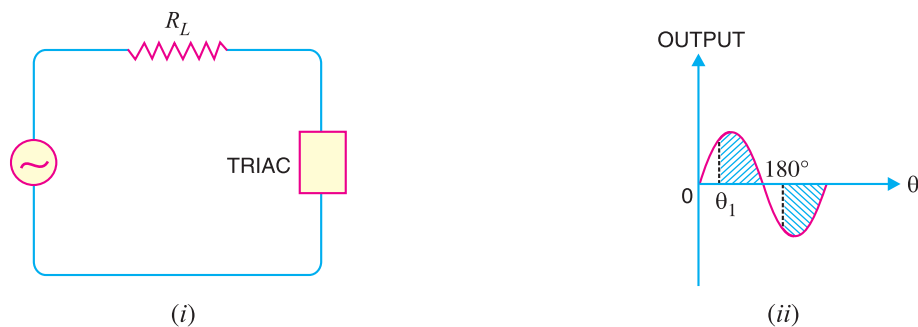

Fig. 21.1

half-cycle of the supply from θ_1 to 180° *i.e.* the shaded portion of positive half-cycle. Similarly, the shaded portion of negative half-cycle will pass through the load. In this way, the alternating current and hence a.c. power flowing through the load can be controlled.

Since a triac can control conduction of both positive and negative half-cycles of a.c. supply, it is sometimes called a bidirectional semi-conductor triode switch. The above action of a triac is cer-

* For example, the speed of a ceiling fan can be changed in four to five steps by electrical method.

** Although it appears that ‘triac’ has two terminals, there is also third terminal connected to the control circuit.

tainly not a rectifying action (as in an *SCR*) so that the triac makes no mention of rectification in its name.

21.3 Triac Construction

A *triac* is a three-terminal, five-layer semiconductor device whose forward and reverse characteristics are identical to the forward characteristics of the *SCR*. The three terminals are designated as main terminal *MT1*, main terminal *MT2* and gate *G*.

Fig. 21.2 (i) shows the basic structure of a triac. As we shall see, a triac is equivalent to two separate *SCRs* connected in inverse parallel (*i.e.* anode of each connected to the cathode of the other) with gates commoned as shown in Fig. 21.2 (ii). Therefore, a triac acts like a bidirectional switch *i.e.* it can conduct current in either direction. This is unlike an *SCR* which can conduct current only in one direction. Fig. 21.2 (iii) shows the schematic symbol of a triac. The symbol consists of two parallel diodes connected in opposite directions with a single gate lead. It can be seen that even the symbol of triac indicates that it can conduct current for either polarity of the main terminals (*MT1* and *MT2*) *i.e.* it can act as a bidirectional switch. The gate provides control over conduction in either direction.

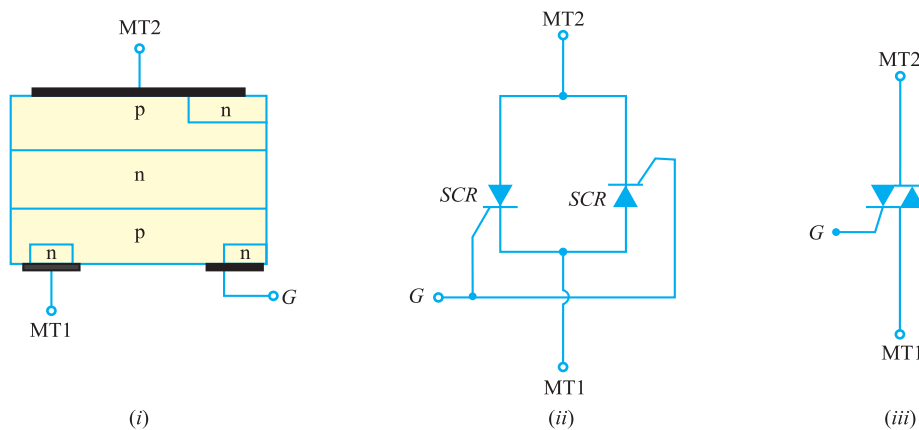

Fig. 21.2

The following points may be noted about the triac :

- (i) The triac can conduct current (of course with proper gate current) regardless of the polarities of the main terminals *MT1* and *MT2*. Since there is no longer a specific anode or cathode, the main leads are referred to as *MT1* and *MT2*.
- (ii) A triac can be turned on either with a positive or negative voltage at the gate of the device.
- (iii) Like the *SCR*, once the triac is fired into conduction, the gate loses all control. The triac can be turned off by reducing the circuit current to the value of holding current.
- (iv) The main disadvantage of triacs over *SCRs* is that triacs have considerably lower current-handling capabilities. Most triacs are available in ratings of less than 40A at voltages up to 600V.

21.4 SCR Equivalent Circuit of Triac

We shall now see that a triac is equivalent to two separate *SCRs* connected in inverse parallel (*i.e.* anode of each connected to the cathode of the other) with gates commoned. Fig. 21.3 (i) shows the basic structure of a triac. If we split the basic structure of a triac into two halves as shown in Fig. 21.3 (ii), it is easy to see that we have two *SCRs* connected in inverse parallel. The left half in Fig. 21.3 (ii) consists of a *pnpn* device ($p_1n_2p_2n_4$) having three *pn* junctions and constitutes *SCR1*. Similarly, the

* *SCR* is a controlled rectifier. It is a unidirectional switch and can conduct only in one direction. Therefore, it can control only one half-cycle (positive or negative) of a.c. supply.

right half in Fig. 21.3 (ii) consists of $pnpn$ device ($p_2n_3p_1n_1$) having three pn junctions and constitutes SCR_2 . The SCR equivalent circuit of the triac is shown in Fig. 21.4.

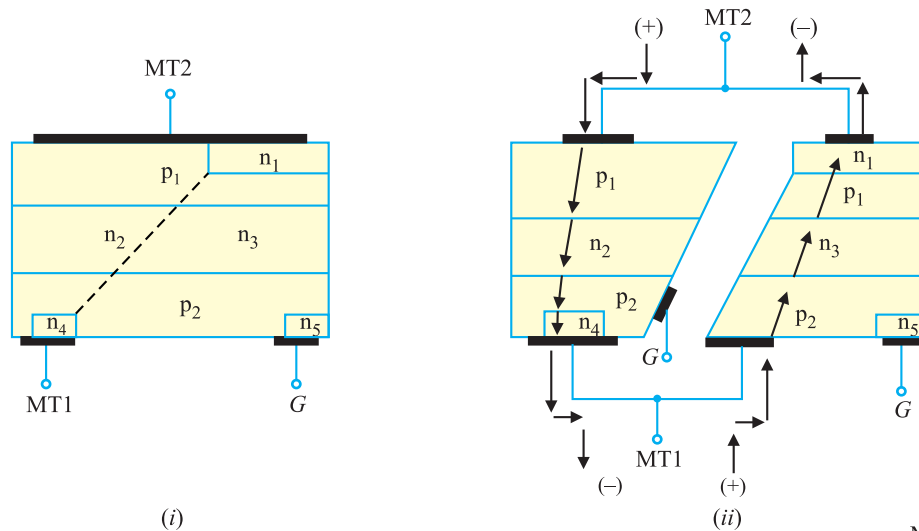

Fig. 21.3

Suppose the main terminal MT_2 is positive and main terminal MT_1 is negative. If the triac is now fired into conduction by proper gate current, the triac will conduct current following the path (left half) shown in Fig. 21.3 (ii). In relation to Fig. 21.4, the SCR_1 is ON and the SCR_2 is OFF . Now suppose that MT_2 is negative and MT_1 is positive. With proper gate current, the triac will be fired into conduction. The current through the devices follows the path (right half) as shown in Fig. 21.3 (ii). In relation to Fig. 21.4, the SCR_2 is ON and the SCR_1 is OFF . Note that the triac will conduct current in the appropriate direction as long as the current through the device is greater than its holding current.

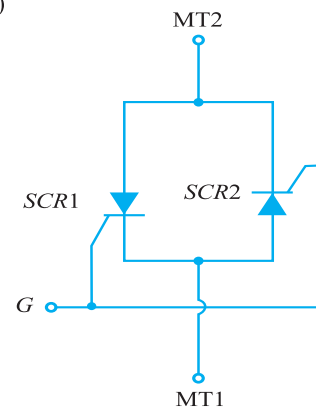

Fig. 21.4

21.5 Triac Operation

Fig. 21.5 shows the simple triac circuit. The a.c. supply to be controlled is connected across the main terminals of triac through a load resistance R_L . The gate circuit consists of battery, a current limiting resistor R and a switch S . The circuit action is as follows :

(i) With switch S open, there will be no gate current and the triac is cut off. Even with no gate current, the triac can be turned on provided the supply voltage becomes equal to the breakover voltage of triac. However, the normal way to turn on a triac is by introducing a proper gate current.

(ii) When switch S is closed, the gate current starts flowing in the gate circuit. In a similar manner to SCR , the breakover voltage of the triac can be varied by making proper gate current to flow. With a few milliamperes introduced at the gate, the triac will start conducting whether terminal MT_2 is positive or negative *w.r.t.* MT_1 .

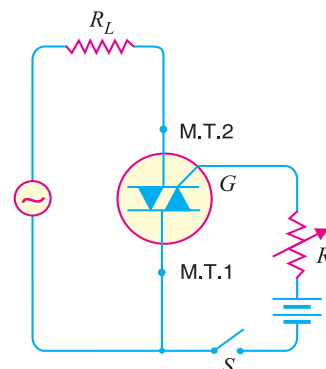

Fig. 21.5

(iii) If terminal *MT2* is positive w.r.t. *MT1*, the triac turns on and the conventional current will flow from *MT2* to *MT1*. If the terminal *MT2* is negative w.r.t. *MT1*, the triac is again turned on but this time the conventional current flows from *MT1* to *MT2*.

The above action of triac reveals that it can act as an *a.c.* contactor to switch on or off alternating current to a load. The additional advantage of triac is that by adjusting the gate current to a proper value, any portion of both positive and negative half-cycles of *a.c.* supply can be made to flow through the load. This permits to adjust the transfer of *a.c.* power from the source to the load.

Example 21.1. Draw the transistor equivalent circuit of a triac and explain its operation from this equivalent circuit.

Solution. We have seen that transistor equivalent circuit of an *SCR* is composed of *pnp* transistor and *npn* transistor with collector of each transistor coupled to the base of the other. Since a triac is equivalent to two *SCRs* connected in inverse parallel (Refer back to Fig. 21.4), the transistor equivalent circuit of triac will be composed of four transistors arranged as shown in Fig. 21.6 (i). The transistors Q_1 and Q_2 constitute the equivalent circuit of *SCR1* while the transistors Q_3 and Q_4 constitute the equivalent circuit of *SCR2*. We can explain the action of triac from its transistor equivalent circuit as under :

(i) When *MT2* is positive w.r.t. *MT1* and appropriate gate current is allowed in the gate circuit, *SCR1* is turned *ON* while *SCR2* remains *OFF*. In terms of transistor equivalent circuit, Q_1 and Q_2 are forward biased while Q_3 and Q_4 are reverse biased. Therefore, transistors Q_1 and Q_2 conduct current as shown in Fig. 21.6 (i). Since Q_1 and Q_2 form a positive feedback, both transistors are quickly driven to saturation and a large current flows through the load R_L . This is as if switch between *MT2* and *MT1* were closed.

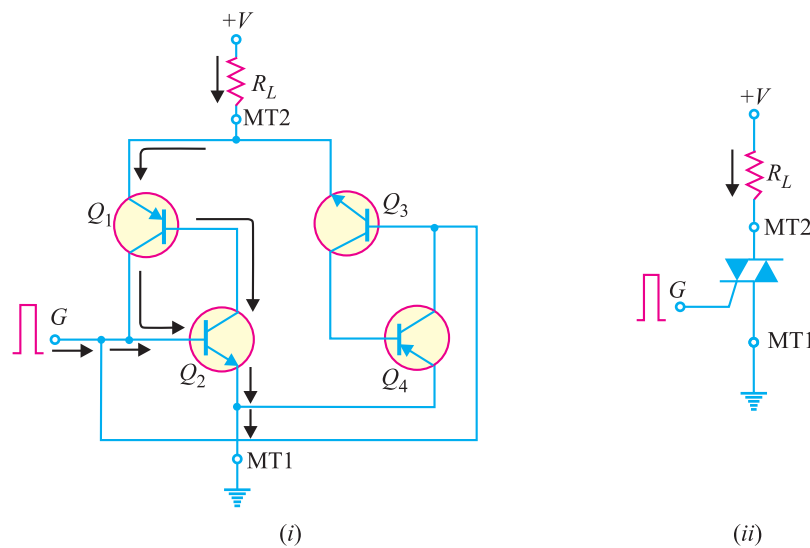

Fig. 21.6

Fig. 21.6 (ii) shows the action of triac (*MT2* positive w.r.t. *MT1*) by replacing the triac with its symbol.

(ii) When *MT2* is negative w.r.t. *MT1* and appropriate gate current is allowed in the gate circuit, *SCR2* is turned *ON* and *SCR1* is *OFF*. In terms of transistor equivalent circuit, Q_3 and Q_4 are forward biased while Q_1 and Q_2 are reverse biased. Therefore, transistors Q_3 and Q_4 will conduct as shown in Fig. 21.7 (i). As explained above, the current in load R_L will quickly attain a large value. The circuit will behave as if a switch is closed between *MT2* and *MT1*.

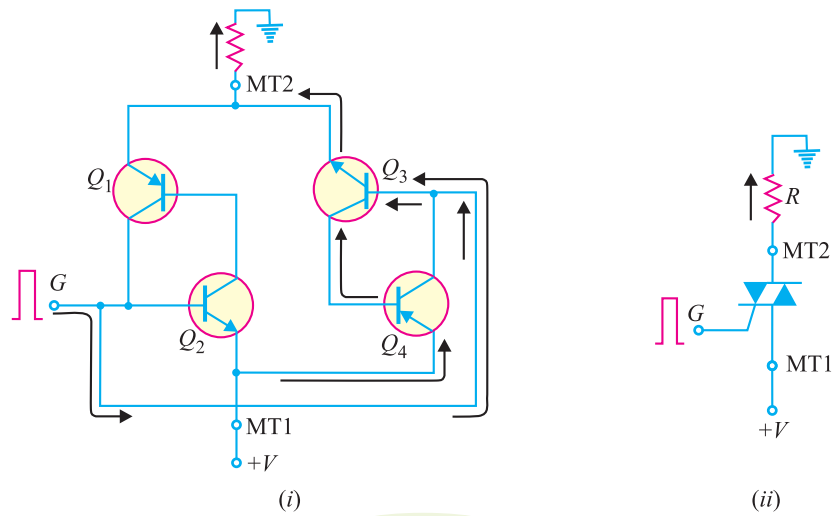

Fig. 21.7

Fig. 21.7 (ii) shows the action of triac ($MT2$ negative w.r.t. $MT1$) by replacing the triac with its symbol.

21.6 Traic Characteristics

Fig. 21.8 shows the $V-I$ characteristics of a triac. Because the triac essentially consists of two SCR s of opposite orientation fabricated in the same crystal, its operating characteristics in the first and third quadrants are the same except for the direction of applied voltage and current flow. The following points may be noted from the triac characteristics :

- (i) The $V-I$ characteristics for triac in the Ist and IIIrd quadrants are essentially identical to those of an SCR in the Ist quadrant.
- (ii) The triac can be operated with either positive or negative *gate* control voltage but in *normal operation usually the gate voltage is positive in quadrant I and negative in quadrant III.

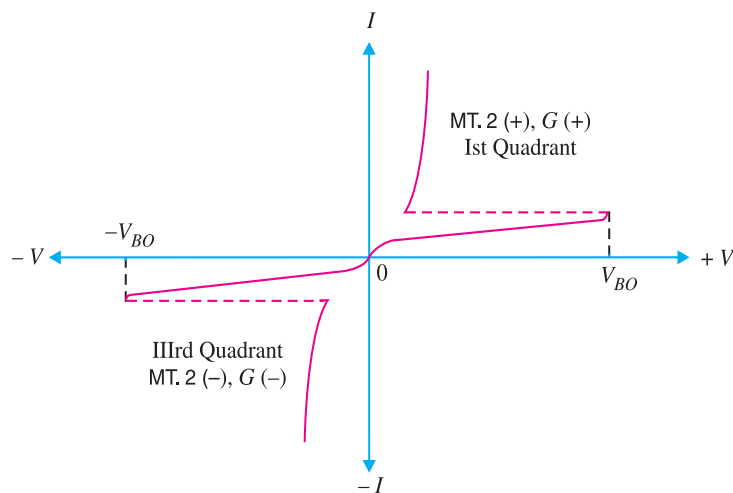

Fig. 21.8

* With this arrangement, less charge is required to turn on the triac.

(iii) The supply voltage at which the triac is turned ON depends upon the gate current. The greater the gate current, the smaller the supply voltage at which the triac is turned on. This permits to use a triac to control a.c. power in a load from zero to full power in a smooth and continuous manner with no loss in the controlling device.

21.7 Triac Phase Control Circuit

A *triac can be used to control the average a.c. power to a load by passing a portion of positive and negative half-cycles of input a.c. This is achieved by changing the conduction angle through the load. Fig. 21.9 shows the basic triac phase control circuit. This circuit uses a capacitor C and variable resistance R_1 to shift the phase angle of the gate signal. Because of this phase shift, the gate voltage lags the line voltage by an angle between 0° and 90° . By adjusting the variable resistance R_1 , the conduction angle through the load can be changed. Thus any portion of positive and negative half-cycles of the a.c. can be passed through the load. This action of triac permits it to be used as a *controlled* **bidirectional switch.

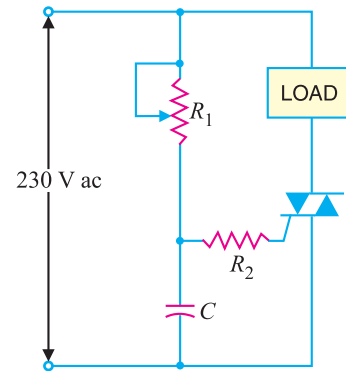

Fig. 21.9

Circuit action. The operation of triac phase control circuit is as under :

(i) During each positive half-cycle of the a.c., the triac is off for a certain interval, called *firing angle α* (measured in degrees) and then it is triggered on and conducts current through the load for the remaining portion of the positive half-cycle, called the *conduction angle θ_c* . The value of firing angle α (and hence θ_c) can be changed by adjusting the variable resistance R_1 . If R_1 is increased, the capacitor will charge more slowly, resulting in the triac being triggered later in the cycle *i.e.* firing angle α is increased while conduction angle θ_c is decreased. As a result, smaller a.c. power is fed to the load. Reverse happens if the resistance R_1 is decreased.

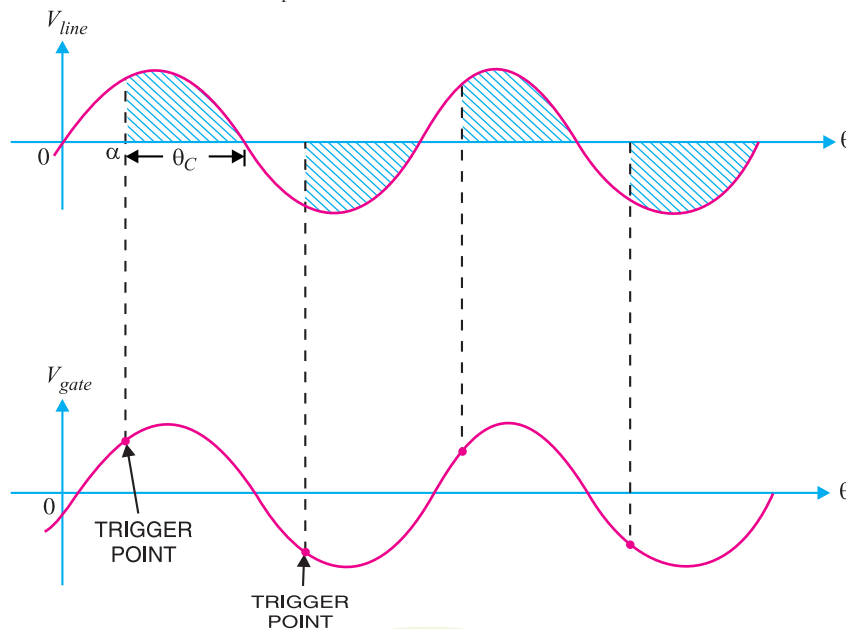

Fig. 21.10

- * An SCR can only control the positive half-cycle or negative half-cycle of a.c.
- ** An SCR is a controlled unidirectional switch because it can conduct only in one direction.

584 ■ Principles of Electronics

(ii) During each negative half-cycle of the a.c., a similar action occurs except that now current in the load is in the opposite direction.

Fig. 21.10 shows the waveforms of the line voltage and gate voltage. Only the shaded portion of the positive and negative half-cycles pass through the load. We can change the phase angle of gate voltage by adjusting the variable resistance R_1 . Thus a triac can control the a.c. power fed to a load. This control of a.c. power is useful in many applications such as industrial heating, lighting etc.

21.8 Applications of Triac

As low gate currents and voltages can be used to control large load currents and voltages, therefore, triac is often used as an electronic on/off switch controlled by a low-current mechanical switch.

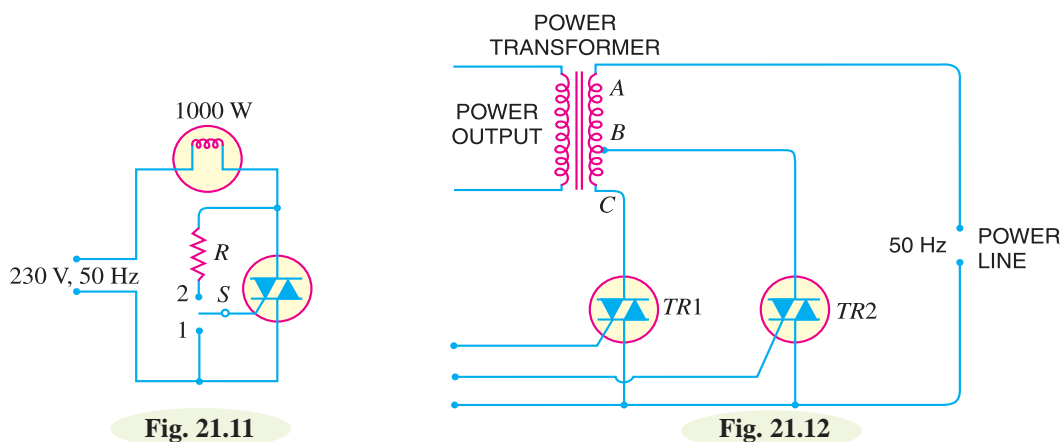
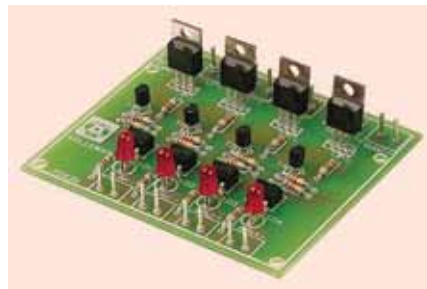

Fig. 21.11

Fig. 21.12

(i) **As a high-power lamp switch.** Fig. 21.11 shows the use of a triac as an a.c. on/off switch. When switch S is thrown to position 1, the triac is cut off and the output power of lamp is zero. But as the switch is thrown to position 2, a small gate current (a few mA) flowing through the gate turns the triac on. Consequently, the lamp is switched on to give full output of 1000 watts.

(ii) **Electronic change over of transformer taps.** Fig. 21.12 shows the circuit of electronic change over of power transformer input taps. Two triacs $TR1$ and $TR2$ are used for the purpose. When triac $TR1$ is turned on and $TR2$ is turned off, the line input is connected across the full transformer primary AC . However, if it is desired to change the tapping so that input appears across part AB of the primary, then $TR2$ is turned on and $TR1$ is turned off. The gate control signals are so controlled that both triacs are never switched on together. This avoids a dangerous short circuit on the section BC of the primary.



Triac as an a.c. switch

Example 21.2. Give a simple method for testing a triac.

Solution. Fig. 21.13 shows a simple circuit for testing a triac. The test lamp serves two purposes. First, it is a visual indicator of current conduction. Secondly, it limits current through the triac.

(i) When switch S is closed, the lamp should not light for the triac to be good. It is because voltage is *applied only between $MT2$ and $MT1$ but there is no trigger voltage. If the lamp lights, the triac is *shorted*.

* It is understood that the applied voltage is less than the breakover voltage of the triac.

(ii) Now touch R_1 momentarily between gate and $MT2$ terminal. For the triac to be good, the lamp should light and *continue to light. If it does not, the triac is *open*.

Note that the lamp is on at full brilliance because the triac conducts both half-cycles (positive and negative) of a.c. This method of triac testing has two main advantages. First, it is a very simple method. Secondly, it does not require expensive apparatus.

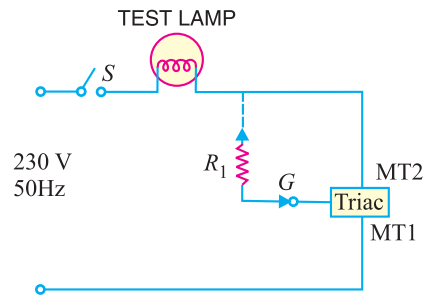

Fig. 21.13

Example 21.3. The triac shown in Fig. 21.14 can be triggered by the gate triggering voltage $V_{GT} = \pm 2V$. How will you trigger the triac by (i) only a positive gate voltage (ii) only a negative gate voltage?

Solution. In Fig. 21.14, the triac will be triggered into conduction for $V_{GT} = \pm 2V$.

(i) In order that the triac is triggered only by a positive gate voltage, we can use the method shown in Fig. 21.15. In this circuit, diode D_1 is forward biased when V_{GT} is positive and reverse biased when V_{GT} is negative. Since D_1 will conduct only when V_{GT} is positive, the triac can only be triggered by a positive gate signal. The voltage V_A required to trigger the device is equal to the sum of V_F for diode D_1 and the required gate triggering voltage *i.e.*

$$V_A = V_F + V_{GT} = 0.7V + 2V = 2.7V$$

(ii) In order that the triac is triggered only by the negative voltage, reverse the direction of diode D_1 .

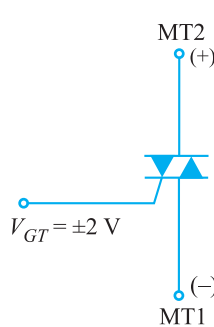

Fig. 21.14

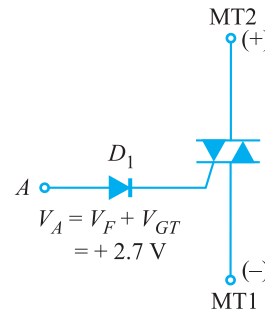

Fig. 21.15

Example 21.4. In Fig. 21.16, the switch is closed. If the triac has fired, what is the current through 50Ω resistor when (i) triac is ideal (ii) triac has a drop of $1V$?

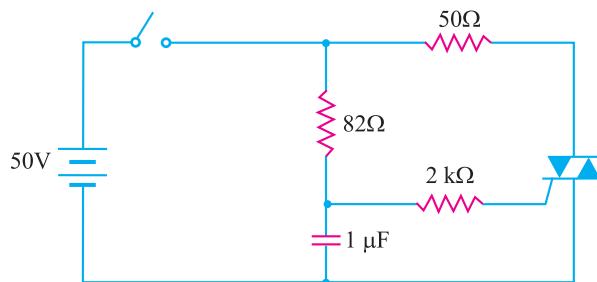

Fig. 21.16

Solution.

(i) Since the triac is ideal and it is fired into conduction, the voltage across triac is $0V$. Therefore, the entire supply voltage of $50V$ appears across 50Ω resistor.

* Recall that once the triac is fired by the gate voltage, it continues to conduct even if the gate voltage is removed.

586 ■ Principles of Electronics

$$\therefore \text{Current in } 50\Omega = \frac{50\text{V}}{50\Omega} = \mathbf{1\text{ A}}$$

(ii) When triac is fired into conduction, voltage across 50Ω resistor = $50\text{V} - 1\text{V} = 49\text{V}$.

$$\therefore \text{Current in } 50\Omega = \frac{49\text{V}}{50\Omega} = \mathbf{0.98\text{ A}}$$

21.9 The Diac

A **diac** is a two-terminal, three layer bidirectional device which can be switched from its OFF state to ON state for either polarity of applied voltage.

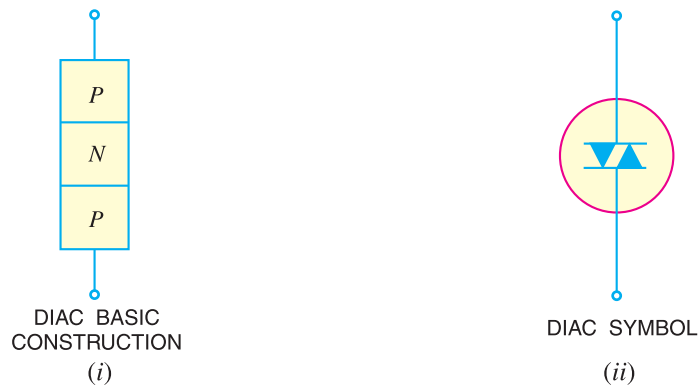

Fig. 21.17

The diac can be constructed in either *npn* or *pnp* form. Fig. 21.17 (i) shows the basic structure of a diac in *pnp* form. The two leads are connected to *p*-regions of silicon separated by an *n*-region. The structure of diac is very much similar to that of a transistor. However, there are several important differences:

- (i) There is no terminal attached to the base layer.
- (ii) The three regions are nearly identical in size.
- (iii) The doping concentrations are identical (unlike a bipolar transistor) to give the device symmetrical properties.

Fig. 21.17 (ii) shows the symbol of a diac.

Operation. When a positive or negative voltage is applied across the terminals of a diac, only a small leakage current I_{BO} will flow through the device. As the applied voltage is increased, the leakage current will continue to flow until the voltage reaches the breakover voltage V_{BO} . At this point, avalanche breakdown of the reverse-biased junction occurs and the device exhibits negative resistance *i.e.* current through the device increases with the decreasing values of applied voltage. The voltage across the device then drops to 'breakback' voltage V_W .

Fig. 21.18 shows the *V-I* characteristics of a diac. For applied positive voltage less than $+V_{BO}$ and negative voltage less than $-V_{BO}$, a small leakage current ($\pm I_{BO}$) flows through the device. Under such conditions, the diac blocks the flow of current and effectively behaves as an open circuit. The voltages $+V_{BO}$ and $-V_{BO}$ are the breakdown voltages and usually have a range of 30 to 50 volts.

When the positive or negative applied voltage is equal to or greater than the breakdown voltage, diac begins to conduct and the voltage drop across it becomes a few volts. Conduction then continues until the device current drops below its holding current. Note that the breakover voltage and holding current values are identical for the forward and reverse regions of operation.

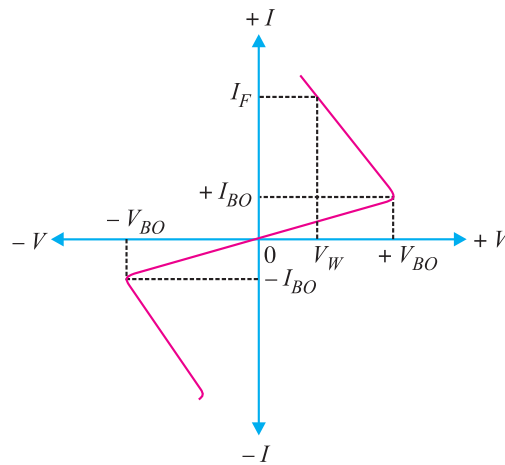

Fig. 21.18

Diacs are used primarily for triggering of triacs in adjustable phase control of a.c. mains power. Some of the circuit applications of diac are (i) light dimming (ii) heat control and (iii) universal motor speed control.

21.10 Applications of Diac

Although a triac may be fired into the conducting state by a simple resistive triggering circuit, more reliable and faster turn-on may be had if a switching device is used in series with the gate. One of the switching devices that can trigger a triac is the diac. This is illustrated in the following applications.

(i) **Lamp dimmer.** Fig. 21.19 shows a typical circuit that may be used for smooth control of a.c. power fed to a lamp. This permits to control the light output from the lamp. The basic control is by an RC variable gate voltage arrangement. The series $R_4 - C_1$ circuit across the triac is designed to limit the rate of voltage rise across the device during switch off.

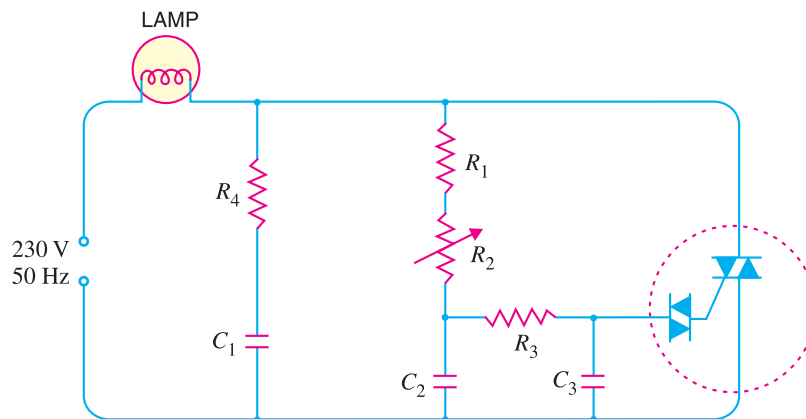

Fig. 21.19

The circuit action is as follows : As the input voltage increases positively or negatively, C_1 and C_2 charge at a rate determined primarily by R_2 . When the voltage across C_3 exceeds the breakover voltage of the diac, the diac is fired into the conducting state. The capacitor C_3 discharges through the conducting diac into the gate of the triac. Hence, the triac is turned on to pass the a.c. power to the

588 ■ Principles of Electronics

lamp. By adjusting the value of R_2 , the rate of charge of capacitors and hence the point at which triac will trigger on the positive or negative half-cycle of input voltage can be controlled. Fig. 21.20 shows the waveforms of supply voltage and load voltage in the diac-triac control circuit



Fig. 21.20

The firing of triac can be controlled upto a maximum of 180° . In this way, we can provide a continuous control of load voltage from practically zero to full *r.m.s.* value.

(ii) Heat control. Fig. 21.21 shows a typical diac-triac circuit that may be used for the smooth control of a.c. power in a heater. This is similar to the circuit shown in Fig. 21.19. The capacitor C_1 in series with choke L across the triac helps to slow-up the voltage rise across the device during switch-off. The resistor R_4 in parallel with the diac ensures smooth control at all positions of variable resistance R_2 .

The circuit action is as follows : As the input voltage increases positively or negatively, C_1 and C_2 charge at a rate determined primarily by R_2 . When the voltage across C_3 exceeds the breakover voltage of the diac, the diac conducts. The capacitor C_3 discharges through the conducting diac into the gate of the triac. This turns on the triac and hence a.c. power to the heater. By adjusting the value of R_2 , any portion of positive and negative half-cycles of the supply voltage can be passed through the heater. This permits a smooth control of the heat output from the heater.

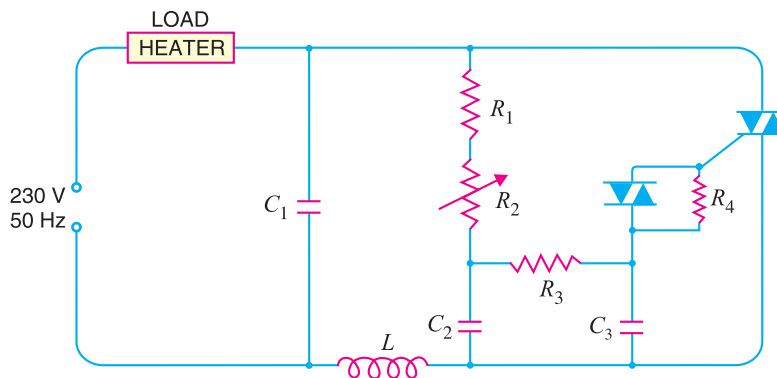

Fig. 21.21

Example 21.5. We require a small gate triggering voltage V_{GT} (say $\pm 2V$) to fire a triac into conduction. How will you raise the trigger level of the triac ?

Solution. The rated values of V_{GT} for triacs are generally low. For example, the triac shown in Fig. 21.22 (i) has $V_{GT} = \pm 2V$. However, we can raise the triggering level of the triac by using a *diac* in the gate circuit as shown in Fig. 21.22 (ii). With the diac present, the triac can still be triggered by both positive and negative gate voltages. However, to fire the triac into conduction, the potential V_A at point A in Fig. 21.22 (ii) must overcome the V_{BO} (breakover voltage) for the diac plus V_{GT} i.e.

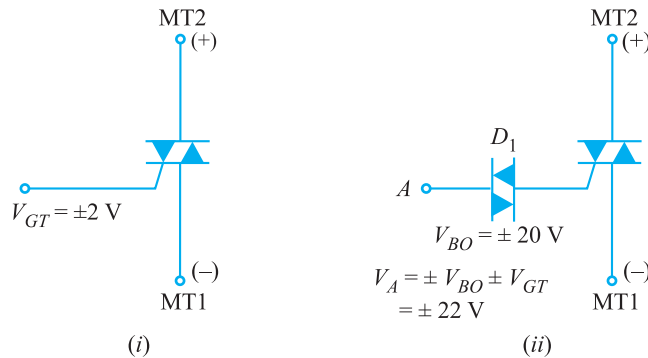

Fig. 21.22

$$V_A = \pm V_{BO} \pm V_{GT}$$

$$= \pm 20V \pm 2V = \pm 22V$$

Therefore, in order to turn on the triac, the gate trigger signal V_A must be $\pm 22V$. Note that triac triggering control is the primary function of a diac.

Example 21.6. In Fig. 21.23, the switch is closed. A diac with breakover voltage $V_{BO} = 30V$ is connected in the circuit. If the triac has a trigger voltage of $1V$ and a trigger current of 10 mA , what is the capacitor voltage that triggers the triac ?

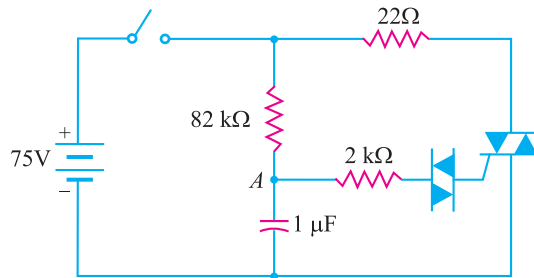

Fig. 21.23

Solution. When switch is closed, the capacitor starts charging and voltage at point A increases. When voltage V_A at point A becomes equal to V_{BO} of diac plus gate triggering voltage V_{GT} of the triac, the triac is fired into conduction.

$$\therefore V_A = V_{BO} + V_{GT} = 30V + 1V = 31V$$

This is the minimum capacitor voltage that will trigger the triac.

21.11 Unijunction Transistor (UJT)

A unijunction transistor (abbreviated as *UJT*) is a three-terminal semiconductor switching device. This device has a unique characteristic that when it is triggered, the emitter current increases regeneratively until it is limited by emitter power supply. Due to this characteristic, the unijunction transistor can be employed in a variety of applications *e.g.*, switching, pulse generator, saw-tooth generator etc.

Construction. Fig. 21.24 (i) shows the basic structure of a unijunction transistor. It consists of an *n*-type silicon bar with an electrical connection on each end. The leads to these connections are

* Note that structure of *UJT* is very much similar to that of the *n*-channel *JFET*. The only difference in the two components is that *p*-type (gate) material of the *JFET* surrounds the *n*-type (channel) material.

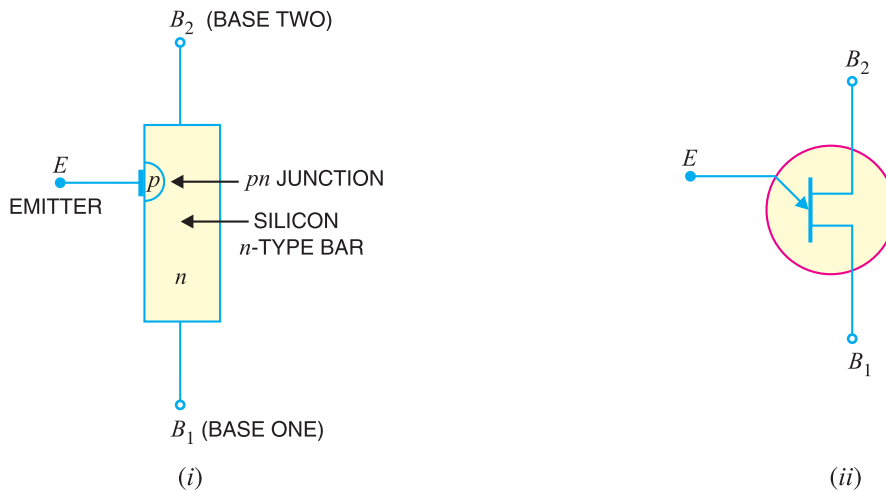

Fig. 21.24

called base leads *base-one* B_1 and *base two* B_2 . Part way along the bar between the two bases, nearer to B_2 than B_1 , a *pn* junction is formed between a *p*-type emitter and the bar. The lead to this junction is called the *emitter lead* E . Fig. 21.24 (ii) shows the symbol of unijunction transistor. Note that emitter is shown closer to B_2 than B_1 . The following points are worth noting :

- (i) Since the device has one *pn* junction and three leads, it is *commonly called a unijunction transistor (*uni* means single).
- (ii) With only one *pn*-junction, the device is really a form of diode. Because the two base terminals are taken from one section of the diode, this device is also called *double-based diode*.
- (iii) The emitter is heavily doped having many holes. The *n* region, however, is lightly doped. For this reason, the resistance between the base terminals is very high (5 to 10 kΩ) when emitter lead is open.

Operation. Fig. 21.25 shows the basic circuit operation of a unijunction transistor. The device has normally B_2 positive *w.r.t.* B_1 .

(i) If voltage V_{BB} is applied between B_2 and B_1 with emitter open [See Fig. 21.25 (i)], a voltage gradient is established along the *n*-type bar. Since the emitter is located nearer to B_2 , more than **half of V_{BB} appears between the emitter and B_1 . The voltage V_1 between emitter and B_1 establishes a

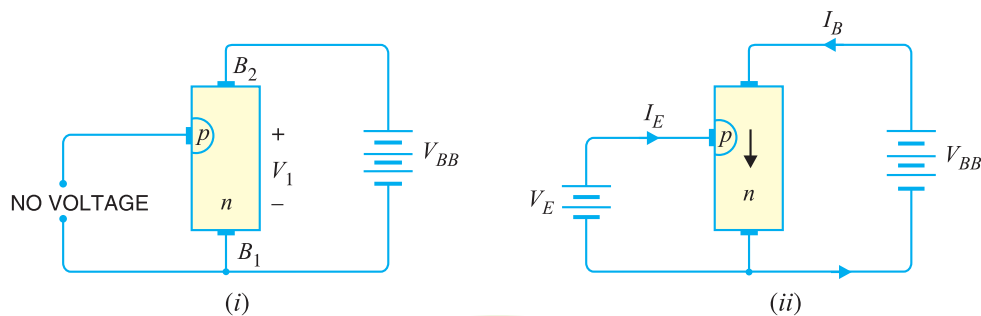

Fig. 21.25

* In packaged form, a *UJT* looks very much like a small signal transistor. As a *UJT* has only one *pn* junction, therefore, naming it a ‘transistor’ is really a misnomer.
 ** The *n*-type silicon bar has a high resistance. The resistance between emitter and B_1 is greater than between B_2 and emitter. It is because emitter is nearer to B_2 than B_1 .

reverse bias on the pn junction and the emitter current is cut off. Of course, a small leakage current flows from B_2 to emitter due to minority carriers.

(ii) If a positive voltage is applied at the emitter [See Fig. 21.25 (ii)], the pn junction will remain reverse biased so long as the input voltage is less than V_1 . If the input voltage to the emitter exceeds V_1 , the pn junction becomes *forward biased. Under these conditions, holes are injected from p -type material into the n -type bar. These holes are repelled by positive B_2 terminal and they are attracted towards B_1 terminal of the bar. This accumulation of holes in the emitter to B_1 region results in the decrease of resistance in this section of the bar. The result is that internal voltage drop from emitter to B_1 is decreased and hence the emitter current I_E increases. As more holes are injected, a condition of saturation will eventually be reached. At this point, the emitter current is limited by emitter power supply only. The device is now in the *ON* state.

(iii) If a negative pulse is applied to the emitter, the pn junction is reverse biased and the emitter current is cut off. The device is then said to be in the *OFF* state.

21.12 Equivalent Circuit of a UJT

Fig. 21.26 shows the equivalent circuit of a *UJT*. The resistance of the silicon bar is called the inter-base resistance R_{BB} . The inter-base resistance is represented by two resistors in series *viz.*

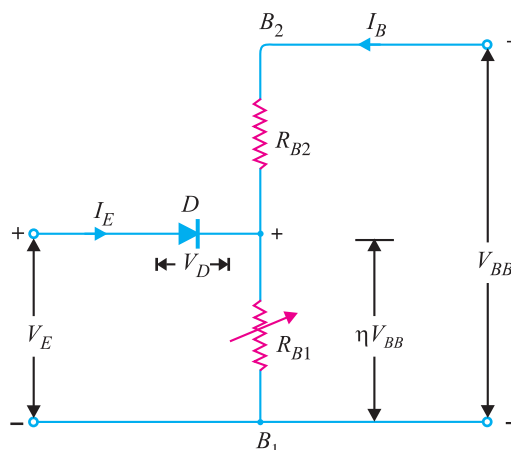

Fig. 21.26

- (a) R_{B2} is the resistance of silicon bar between B_2 and the point at which the emitter junction lies.
- (b) R_{B1} is the resistance of the bar between B_1 and emitter junction. This resistance is shown variable because its value depends upon the bias voltage across the pn junction.

The pn junction is represented in the emitter by a diode D .

The circuit action of a *UJT* can be explained more clearly from its equivalent circuit.

- (i) With no voltage applied to the *UJT*, the inter-base resistance is given by ;

$$R_{BB} = R_{B1} + R_{B2}$$

The value of R_{BB} generally lies between 4 k Ω and 10 k Ω .

- (ii) If a voltage V_{BB} is applied between the bases with emitter open, the voltage will divide up across R_{B1} and R_{B2} .

$$\text{Voltage across } R_{B1}, V_1 = \frac{R_{B1}}{R_{B1} + R_{B2}} V_{BB}$$

* The main operational difference between the *JFET* and the *UJT* is that the *JFET* is normally operated with the gate junction reverse biased whereas the useful behaviour of the *UJT* occurs when the emitter is forward biased.

592 ■ Principles of Electronics

or
$$V_1/V_{BB} = \frac{R_{B1}}{R_{B1} + R_{B2}}$$

The ratio V_1/V_{BB} is called *intrinsic stand-off ratio* and is represented by Greek letter η .

Obviously,
$$\eta = \frac{R_{B1}}{R_{B1} + R_{B2}}$$

The value of η usually lies between 0.51 and 0.82.

\therefore Voltage across $R_{B1} = \eta V_{BB}$

The voltage ηV_{BB} appearing across R_{B1} reverse biases the diode. Therefore, the emitter current is zero.

(iii) If now a progressively rising positive voltage is applied to the emitter, the diode will become forward biased when input voltage exceeds ηV_{BB} by V_D , the forward voltage drop across the silicon diode *i.e.*

$$V_P = \eta V_{BB} + V_D$$

where

$$V_P = \text{'peak point voltage'}$$

$$V_D = \text{forward voltage drop across silicon diode } (\approx 0.7 \text{ V})$$

When the diode D starts conducting, holes are injected from p -type material to the n -type bar. These holes are swept down towards the terminal B_1 . This decreases the resistance between emitter and B_1 (indicated by variable resistance symbol for R_{B1}) and hence the internal drop from emitter to B_1 . The emitter current now increases regeneratively until it is limited by the emitter power supply.

Conclusion. The above discussion leads to the conclusion that when input positive voltage to the emitter is less than peak-point voltage V_P , the pn -junction remains reverse biased and the emitter current is practically zero. However, when the input voltage exceeds V_P , R_{B1} falls from several thousand ohms to a small value. The diode is now forward biased and the emitter current quickly reaches to a saturation value limited by R_{B1} (about 20 Ω) and forward resistance of pn -junction (about 200 Ω).

21.13 Characteristics of UJT

Fig. 21.27 shows the curve between emitter voltage (V_E) and emitter current (I_E) of a *UJT* at a given voltage V_{BB} between the bases. This is known as the emitter characteristic of *UJT*. The following points may be noted from the characteristics :

(i) Initially, in the cut-off region, as V_E increases from zero, slight leakage current flows from terminal B_2 to the emitter. This current is due to the minority carriers in the reverse biased diode.

(ii) Above a certain value of V_E , forward I_E begins to flow, increasing until the peak voltage V_P and current I_P are reached at point P .

(iii) After the peak point P , an attempt to increase V_E is followed by a sudden increase in emitter current I_E with a corresponding decrease in V_E . This is a *negative resistance* portion of the curve because with increase in I_E , V_E decreases. The device, therefore, has a negative resistance region which is stable enough to be used with a great deal of reliability in many areas *e.g.*, trigger circuits, saw-tooth generators, timing circuits .

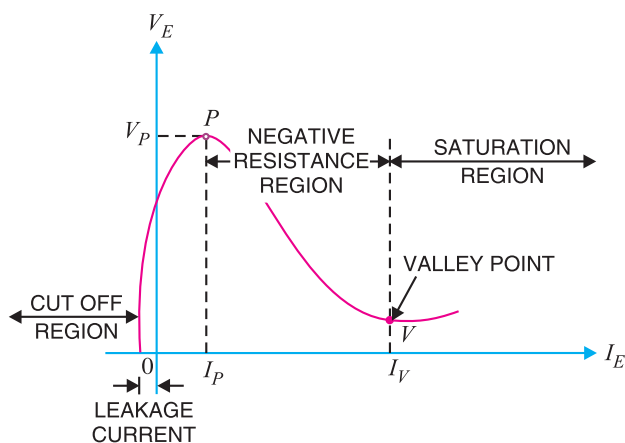

Fig. 21.27

(iv) The negative portion of the curve lasts until the valley point V is reached with valley-point voltage V_V and valley-point current I_V . After the valley point, the device is driven to saturation.

Fig. 21.28 shows the typical family of V_E/I_E characteristics of a UJT at different voltages between the bases. It is clear that peak-point voltage ($= \eta V_{BB} + V_D$) falls steadily with reducing V_{BB} and so does the valley point voltage V_V . The difference $V_P - V_V$ is a measure of the switching efficiency of UJT and can be seen to fall off as V_{BB} decreases. For a general purpose UJT, the peak - point current is of the order of $1 \mu\text{A}$ at $V_{BB} = 20 \text{ V}$ with a valley-point voltage of about 2.5 V at 6 mA .

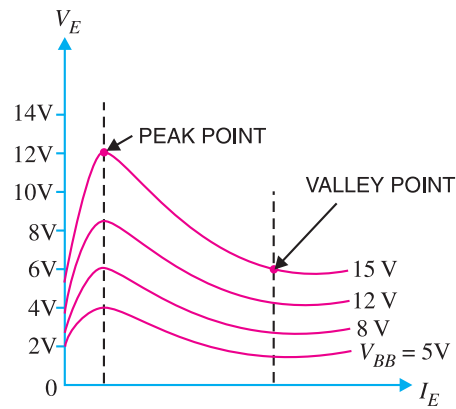

Fig. 21.28

Example 21.7. The intrinsic stand-off ratio for a UJT is determined to be 0.6. If the inter-base resistance is $10 \text{ k}\Omega$, what are the values of R_{B1} and R_{B2} ?

Solution.

$$R_{BB} = 10 \text{ k}\Omega, \quad \eta = 0.6$$

Now

$$R_{BB} = R_{B1} + R_{B2}$$

or

$$10 = R_{B1} + R_{B2}$$

Also

$$\eta = \frac{R_{B1}}{R_{B1} + R_{B2}}$$

or

$$0.6 = \frac{R_{B1}}{10} \quad (\because R_{B1} + R_{B2} = 10 \text{ k}\Omega)$$

\therefore

$$R_{B1} = 10 \times 0.6 = \mathbf{6 \text{ k}\Omega}$$

and

$$R_{B2} = 10 - 6 = \mathbf{4 \text{ k}\Omega}$$

Example 21.8. A unijunction transistor has 10 V between the bases. If the intrinsic stand off ratio is 0.65, find the value of stand off voltage. What will be the peak-point voltage if the forward voltage drop in the pn junction is 0.7 V ?

Solution.

$$V_{BB} = 10 \text{ V}; \quad \eta = 0.65; \quad V_D = 0.7 \text{ V}$$

$$\text{Stand off voltage} = \eta V_{BB} = 0.65 \times 10 = \mathbf{6.5 \text{ V}}$$

$$\text{Peak-point voltage, } V_P = \eta V_{BB} + V_D = 6.5 + 0.7 = \mathbf{7.2 \text{ V}}$$

Example 21.9. Determine the maximum and minimum peak-point voltage for a UJT with $V_{BB} = 25 \text{ V}$. Given that UJT has a range of $\eta = 0.74$ to 0.86 .

Solution.

$$V_{BB} = 25 \text{ V}; \quad \eta_{\max} = 0.86 ; \quad \eta_{\min} = 0.74$$

\therefore

$$\begin{aligned} V_{P(\max)} &= \eta_{\max} V_{BB} + V_D \\ &= (0.86) (25\text{V}) + 0.7 \text{ V} = \mathbf{22.2 \text{ V}} \end{aligned}$$

$$\begin{aligned} V_{P(\min)} &= \eta_{\min} V_{BB} + V_D \\ &= (0.74) (25 \text{ V}) + 0.7 \text{ V} = \mathbf{19.2 \text{ V}} \end{aligned}$$

Example 21.10. Fig. 21.29 (i) shows the UJT circuit. The parameters of UJT are $\eta = 0.65$ and $R_{BB} = 7 \text{ k}\Omega$. Find (i) R_{B1} and R_{B2} (ii) $V_{B1 B2}$ and V_P .

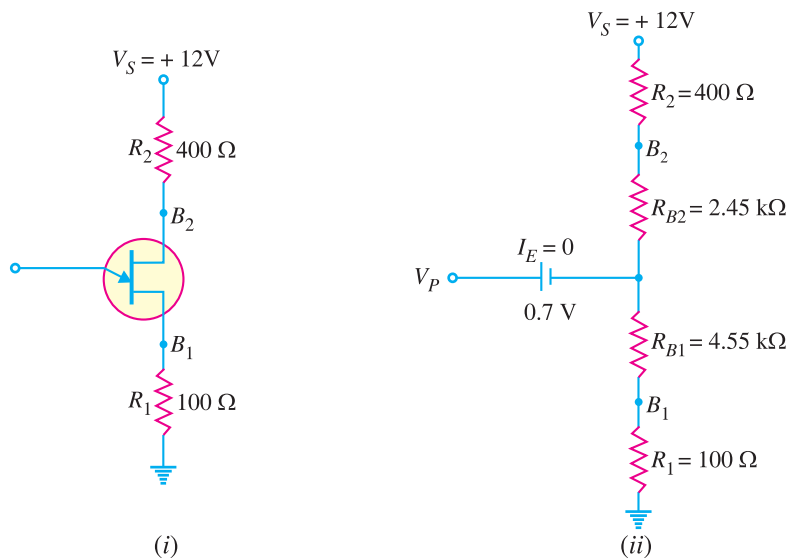

Fig. 21.29

Solution.

$\eta = 0.65 ; V_S = 12\text{ V} ; R_{BB} = 7\ \text{k}\Omega$

(i) $\eta = \frac{R_{B1}}{R_{BB}} \quad \therefore R_{B1} = \eta R_{BB} = 0.65 \times 7\ \text{k}\Omega = 4.55\ \text{k}\Omega$

Also $R_{B2} = R_{BB} - R_{B1} = 7\ \text{k}\Omega - 4.55\ \text{k}\Omega = 2.45\ \text{k}\Omega$

(ii) Fig. 21.29 (ii) shows the UJT circuit model. Because UJT is OFF, $I_E = 0$. We can find V_{B2B1} by the voltage-divider rule.

$$V_{B2B1} = \frac{V_S}{R_1 + R_2 + R_{BB}} \times R_{BB}$$

$$= \frac{12\text{V}}{(100 + 400 + 7000)\Omega} \times 7000\Omega = 11.2\text{V}$$

The voltage V_P required to turn on the UJT is

$V_P = \eta V_{B2B1} + V_D = 0.65 \times 11.2\text{ V} + 0.7\text{ V} = 7.98\text{V}$

21.14 Advantages of UJT

The UJT was introduced in 1948 but did not become commercially available until 1952. Since then, the device has achieved great popularity due to the following reasons :

- (i) It is a low cost device.
- (ii) It has excellent characteristics.
- (iii) It is a low-power absorbing device under normal operating conditions.

Due to above reasons, this device is being used in a variety of applications. A few include oscillators, trigger circuits, saw-tooth generators, bistable network etc.

21.15 Applications of UJT

Unijunction transistors are used extensively in oscillator, pulse and voltage sensing circuits. Some of the important applications of UJT are discussed below :

(i) **UJT relaxation oscillator.** Fig. 21.30 shows *UJT* relaxation oscillator where the discharging of a capacitor through *UJT* can develop a saw-tooth output as shown.

When battery V_{BB} is turned on, the capacitor C charges through resistor R_1 . During the charging period, the voltage across the capacitor rises in an exponential manner until it reaches the peak - point voltage. At this instant of time, the *UJT* switches to its low resistance conducting mode and the capacitor is discharged between E and B_1 . As the capacitor voltage flies back to zero, the emitter ceases to conduct and the *UJT* is switched off. The next cycle then begins, allowing the capacitor C to charge again. The frequency of the output saw-tooth wave can be varied by changing the value of R_1 since this controls the time constant R_1C of the capacitor charging circuit.

The time period and hence the frequency of the saw-tooth wave can be calculated as follows. Assuming that the capacitor is initially uncharged, the voltage V_C across the capacitor prior to breakdown is given by :

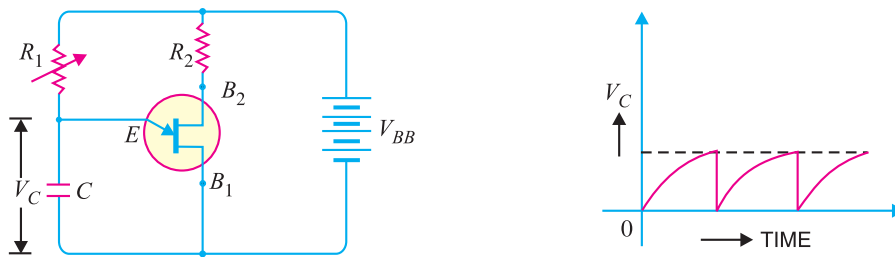

Fig. 21.30

$$V_C = V_{BB} (1 - e^{-t/R_1C})$$

where

R_1C = charging time constant of resistor-capacitor circuit

t = time from the commencement of waveform.

The discharge of the capacitor occurs when V_C is equal to the *peak-point voltage ηV_{BB} i.e.

$$\eta V_{BB} = V_{BB} (1 - e^{-t/R_1C})$$

or

$$\eta = 1 - e^{-t/R_1C}$$

or

$$e^{-t/R_1C} = 1 - \eta$$

or

$$t = R_1 C \log_e \frac{1}{1 - \eta}$$

∴

$$\text{Time period, } t = 2.3 R_1 C \log_{10} \frac{1}{1 - \eta}$$

$$\text{Frequency of saw-tooth wave, } f = \frac{1}{t \text{ in seconds}} \text{ Hz}$$

(ii) **Overvoltage detector.** Fig. 21.31 shows a simple d.c. over-voltage indicator. A warning pilot - lamp L is connected between the emitter and B_1 circuit. So long as the input voltage is less than the peak-point voltage (V_p) of the *UJT*, the device remains switched off. However, when the input voltage exceeds V_p , the *UJT* is switched on and the capacitor discharges through the low resistance path between terminals E and B_1 . The current flowing in the pilot lamp L lights it, thereby indicating the overvoltage in the circuit.

* Actually, peak point voltage, $V_p = \eta V_{BB} + V_D$. As V_D , the forward voltage drop across emitter diode is generally small, it can be neglected with reasonable accuracy.

$$\therefore V_p = \eta V_{BB}$$

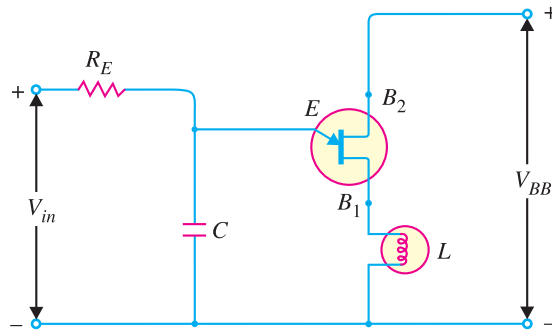

Fig. 21.31

Example 21.11. The circuit shown in Fig. 21.32 uses variable resistor R_E to change the frequency of pulses delivered at V_{out} . The variable resistor is initially set at $5\text{ k}\Omega$ and is then adjusted to $10\text{ k}\Omega$. Determine the frequency of the voltage spikes produced for (i) $5\text{ k}\Omega$ setting and (ii) $10\text{ k}\Omega$ setting.

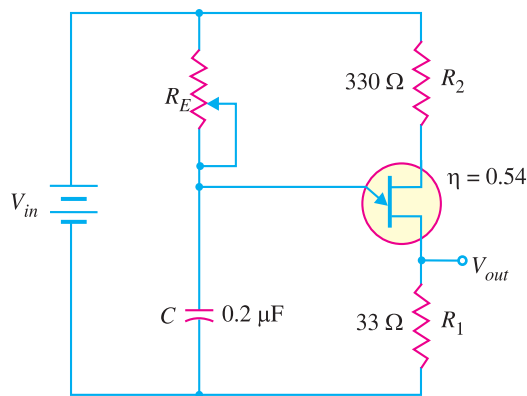

Fig. 21.32

Solution.

(i) Time period, $t = R_E C \log_e \frac{1}{1-\eta}$

Here $R_E = 5\text{ k}\Omega = 5 \times 10^3\Omega$; $C = 0.2\ \mu\text{F} = 0.2 \times 10^{-6}\text{ F}$; $\eta = 0.54$

$\therefore t = (5 \times 10^3) (0.2 \times 10^{-6}) \log_e \frac{1}{1-0.54}$
 $= 0.78 \times 10^{-3}\text{ s} = 0.78\text{ ms}$

\therefore Frequency, $f = 1/t = 1/0.78 \times 10^{-3}\text{ s} = \mathbf{1282\text{ Hz}}$

(ii) $t = (10 \times 10^3) (0.2 \times 10^{-6}) \log_e \frac{1}{1-0.54}$
 $= 1.55 \times 10^{-3}\text{ s} = 1.55\text{ ms}$

\therefore Frequency, $f = 1/t = 1/1.55 \times 10^{-3}\text{ s} = \mathbf{645\text{ Hz}}$

Example 21.12. Fig. 21.33 (i) shows the relaxation oscillator. The parameters of the UJT are $R_{BB} = 5\text{ k}\Omega$ and $\eta = 0.6$.

- (i) Determine R_{B1} and R_{B2} at $I_E = 0$.
- (ii) Calculate the voltage V_P necessary to turn on the UJT.
- (iii) Determine the frequency of oscillations.

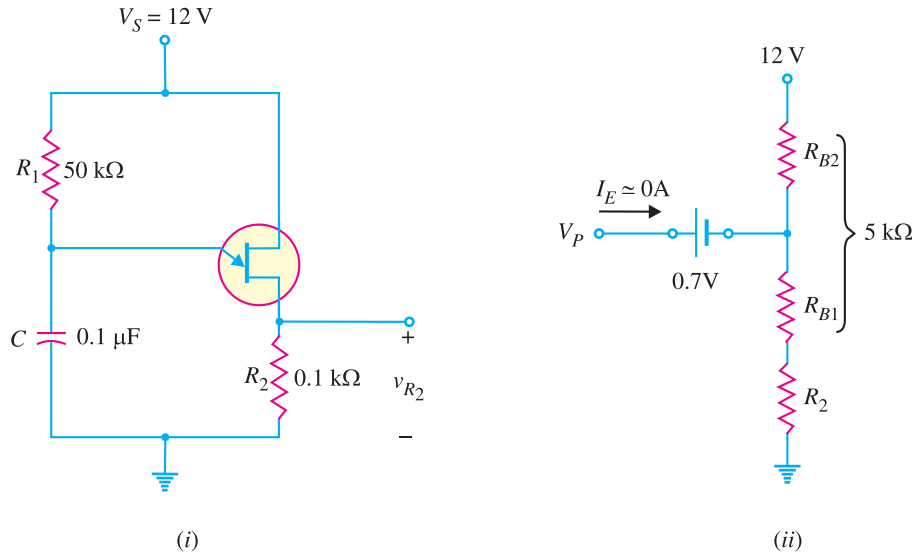

Fig. 21.33

Solution.

$$V_S = 12; R_{BB} = 5 \text{ k}\Omega; \eta = 0.6$$

(i)
$$\eta = \frac{R_{B1}}{R_{BB}} \quad \text{or} \quad R_{B1} = \eta R_{BB} = 0.6 \times 5 \text{ k}\Omega = 3 \text{ k}\Omega$$

Also
$$R_{B2} = R_{BB} - R_{B1} = 5 \text{ k}\Omega - 3 \text{ k}\Omega = 2 \text{ k}\Omega$$

(ii) The voltage V_P required to turn on the UJT can be found from the UJT circuit model shown in Fig. 21.33 (ii). Referring to Fig. 21.33 (ii), we have,

$$\begin{aligned} V_P &= V_D + \text{Voltage drop across } (R_{B1} + R_2) \\ &= V_D + \frac{V_S}{R_{BB} + R_2} \times (R_{B1} + R_2) \\ &= 0.7\text{V} + \frac{12\text{V}}{5 \text{ k}\Omega + 0.1 \text{ k}\Omega} \times (3 + 0.1) \text{ k}\Omega \\ &= 0.7\text{V} + 7.294 \text{ V} ; \quad \mathbf{8\text{V}} \end{aligned}$$

(iii) Time period,
$$t = R_1 C \log_e \frac{1}{1 - \eta}$$

Here $R_1 = 50 \text{ k}\Omega = 50 \times 10^3 \Omega$; $C = 0.1 \mu\text{F} = 0.1 \times 10^{-6} \text{F}$; $\eta = 0.6$

$$\begin{aligned} \therefore t &= (50 \times 10^3) (0.1 \times 10^{-6}) \log_e \frac{1}{1 - 0.6} \\ &= 4.58 \times 10^{-3} \text{s} = 4.58 \text{ ms} \end{aligned}$$

$$\therefore \text{Frequency, } f = \frac{1}{t} = \frac{1}{4.58 \times 10^{-3} \text{s}} = \mathbf{218 \text{ Hz}}$$

MULTIPLE-CHOICE QUESTIONS

1. A triac has three terminals viz.
 - (i) drain, source, gate
 - (ii) two main terminal and a gate terminal
 - (iii) cathode, anode, gate
 - (iv) none of the above
2. A triac is equivalent to two SCRs
 - (i) in parallel
 - (ii) in series
 - (iii) in inverse-parallel
 - (iv) none of the above
3. A triac is a switch.
 - (i) bidirectional
 - (ii) unidirectional
 - (iii) mechanical
 - (iv) none of the above
4. The V - I characteristics for a triac in the first and third quadrants are essentially identical to those of in the first quadrant.
 - (i) transistor (ii) SCR
 - (iii) UJT (iv) none of the above
5. A triac can pass a portion of half-cycle through the load.
 - (i) only positive
 - (ii) only negative
 - (iii) both positive and negative
 - (iv) none of the above
6. A diac has terminals.
 - (i) two (ii) three
 - (iii) four (iv) none of the above
7. A triac has semiconductor layers.
 - (i) two (ii) three
 - (iii) four (iv) five
8. A diac has pn junctions.
 - (i) four (ii) two
 - (iii) three (iv) none of the above
9. The device that does not have the gate terminal is
 - (i) triac (ii) FET
 - (iii) SCR (iv) diac
10. A diac has semiconductor layers.
 - (i) three (ii) two
 - (iii) four (iv) none of the above
11. A UJT has
 - (i) two pn junctions
 - (ii) one pn junction
 - (iii) three pn junctions
 - (iv) none of the above
12. The normal way to turn on a diac is by
 - (i) gate current
 - (ii) gate voltage
 - (iii) breakover voltage
 - (iv) none of the above
13. A diac is switch.
 - (i) an a.c. (ii) a d.c.
 - (iii) a mechanical (iv) none of the above
14. In a UJT, the p -type emitter is doped.
 - (i) lightly (ii) heavily
 - (iii) moderately (iv) none of the above
15. Power electronics essentially deals with control of a.c. power at
 - (i) frequencies above 20 kHz
 - (ii) frequencies above 1000 kHz
 - (iii) frequencies less than 10 Hz
 - (iv) 50 Hz frequency
16. When the emitter terminal of a UJT is open, the resistance between the base terminals is generally
 - (i) high (ii) low
 - (iii) extremely low (iv) none of the above
17. When a UJT is turned ON, the resistance between emitter terminal and lower base terminal
 - (i) remains the same
 - (ii) is decreased
 - (iii) is increased
 - (iv) none of the above
18. To turn on UJT, the forward bias on the emitter diode should be the peak point voltage.
 - (i) less than (ii) equal to
 - (iii) more than (iv) none of the above
19. A UJT is sometimes called diode.

- (i) low resistance (ii) high resistance
(iii) single-base (iv) double-based
20. When the temperature increases, the inter-base resistance (R_{BB}) of a *UJT*
- (i) increases
(ii) decreases
(iii) remains the same
(iv) none of the above
21. The intrinsic stand off ratio (η) of a *UJT* is given by
- (i) $R_{B1} + R_{B2}$ (ii) $\frac{R_{B1} + R_{B2}}{R_{B1}}$
(iii) $\frac{R_{B1}}{R_{B1} + R_{B2}}$ (iv) $\frac{R_{B1} + R_{B2}}{R_{B2}}$
22. When the temperature increases, the intrinsic stand off ratio
- (i) increases
(ii) decreases
(iii) essentially remains the same
(iv) none of the above
23. Between the peak point and the valley point of *UJT* emitter characteristics we have region.
- (i) saturation (ii) negative resistance
(iii) cut-off (iv) none of the above
24. A diac is turned on by
- (i) breakover voltage
(ii) gate voltage
(iii) gate current
(iv) none of the above
25. The device that exhibits negative resistance region is
- (i) diac (ii) triac
(iii) transistor (iv) *UJT*
26. The *UJT* may be used as
- (i) an amplifier
(ii) a sawtooth generator
(iii) a rectifier
(iv) none of the above
27. A diac is simply
- (i) a single junction device
(ii) a three junction device
(iii) a triac without gate terminal
(iv) none of the above
28. After peak point, the *UJT* operates in the region.
- (i) cut-off
(ii) saturation
(iii) negative resistance
(iv) none of the above
29. Which of the following is *not* a characteristic of *UJT* ?
- (i) intrinsic stand off ratio
(ii) negative resistance
(iii) peak-point voltage
(iv) bilateral conduction
30. The triac is
- (i) like a bidirectional *SCR*
(ii) a four-terminal device
(iii) not a thyristor
(iv) answers (i) and (ii)

Answers to Multiple-Choice Questions

- | | | | | |
|-----------|-----------|-----------|----------|----------|
| 1. (ii) | 2. (iii) | 3. (i) | 4. (ii) | 5. (iii) |
| 6. (i) | 7. (iii) | 8. (ii) | 9. (iv) | 10. (i) |
| 11. (ii) | 12. (iii) | 13. (i) | 14. (ii) | 15. (iv) |
| 16. (i) | 17. (ii) | 18. (iii) | 19. (iv) | 20. (i) |
| 21. (iii) | 22. (iii) | 23. (ii) | 24. (i) | 25. (iv) |
| 26. (ii) | 27. (iii) | 28. (iii) | 29. (iv) | 30. (i) |

Chapter Review Topics

1. Discuss the importance of power electronics.
2. Explain the construction and working of a triac.

600 ■ Principles of Electronics

- Sketch the V - I characteristics of a triac. What do you infer from them?
- Describe some important applications of a triac.
- Explain the construction and working of a diac.
- Discuss the applications of a diac.
- Explain the construction and working of a UJT .
- Draw the equivalent circuit of a UJT and discuss its working from the circuit.
- Describe some important applications of a UJT .
- Write short notes on the following :
 - UJT relaxation oscillator
 - Triac as an a.c. switch
 - Diac as a triggering device

Problems

- The intrinsic stand off ratio for a UJT is determined to be 0.6. If the inter-base resistance is $5\text{ k}\Omega$, what are the values of R_{B1} and R_{B2} ? [$R_{B1} = 3\text{ k}\Omega$; $R_{B2} = 2\text{ k}\Omega$]
- A unijunction transistor has 18 V between the bases. If the intrinsic stand off ratio is 0.8, find the value of stand off voltage. What will be the peak point voltage if the forward voltage drop in the pn junction is 0.7 V ? [14.4 V ; 15.1 V]
- In a unijunction transistor, $\eta = 0.8$, $V_p = 10.3\text{ V}$ and $R_{B2} = 5\text{ k}\Omega$. Determine R_{B1} and V_{BB} . [$20\text{ k}\Omega$; 12 V]
- The intrinsic stand-off ratio for a UJT is 0.75 and $V_{BB} = 12\text{ V}$. If the forward drop in the pn -junction is 0.7 V , find the peak point voltage. [9.7 V]
- A unijunction transistor has 12 V between the bases. If the intrinsic stand off ratio is $2/3$, find the value of stand-off voltage. What will be the peak point voltage if the forward drop in the pn junction is 0.7 V ? [8 V ; 8.7 V]
- In Fig. 21.34, the switch is closed. If the triac has fired, what is the current through the 22Ω ? [3.41 A]

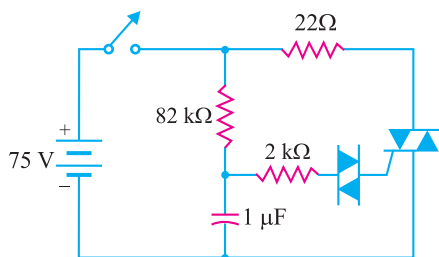

Fig. 21.34

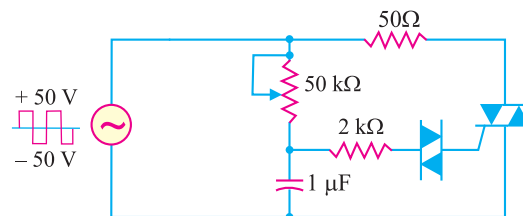

Fig. 21.35

- If the triac of Fig. 21.35 has 1 V across it when it is conducting, what is the maximum current through the 50Ω ? [0.98 A]

Discussion Questions

- What are the advantages of a triac over an SCR?
- Why is diac preferred to trigger a triac?
- Why is power electronics so important?
- Why is diac used to trigger a triac?
- Is the name UJT appropriate?
- What is the most common application of diac?
- What are the symptoms of a *shorted* diac or triac?
- What are the symptoms of an *open* diac or triac?
- For what are UJT s used?